

P. GRAY.
SIGNAL LANTERN.

No. 521,162.

Patented June 12, 1894.

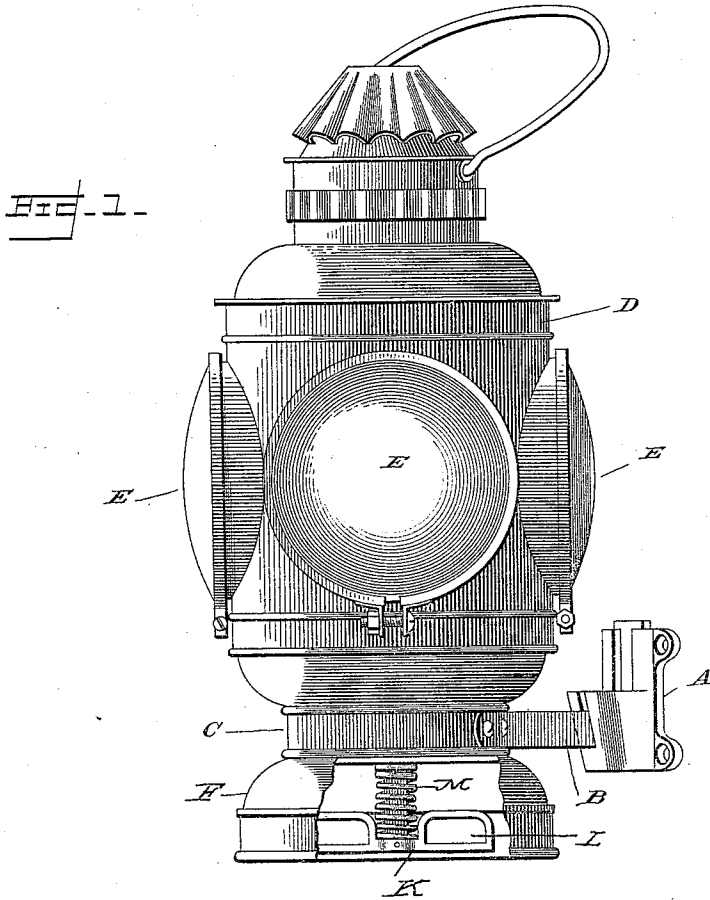

FIG. 1.

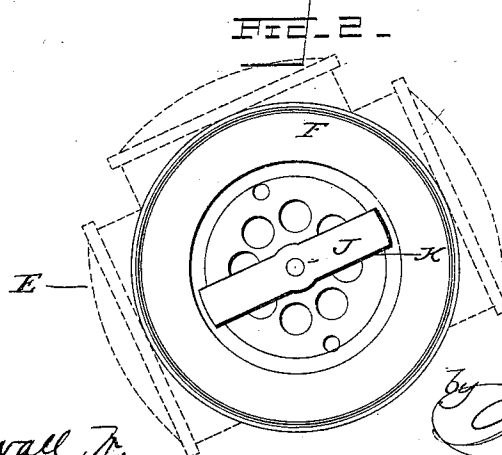

FIG. 2.

Witnesses
Edw. S. Duwall Jr.
May E. Moore

Peter Gray.
 Inventor
 by *Amos Moore*
 Attorney

P. GRAY.
SIGNAL LANTERN.

No. 521,162.

Patented June 12, 1894.

FIG. 4.

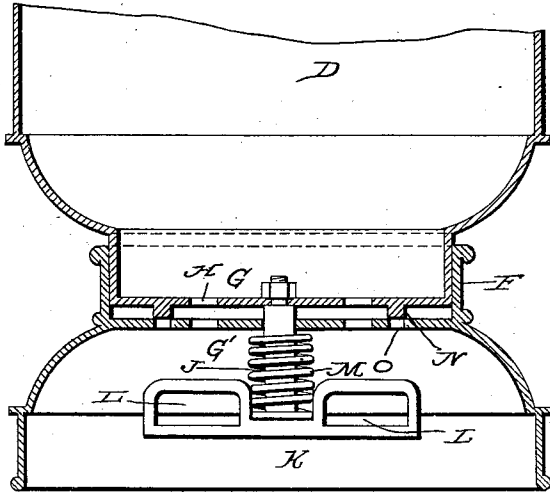

FIG. 3.

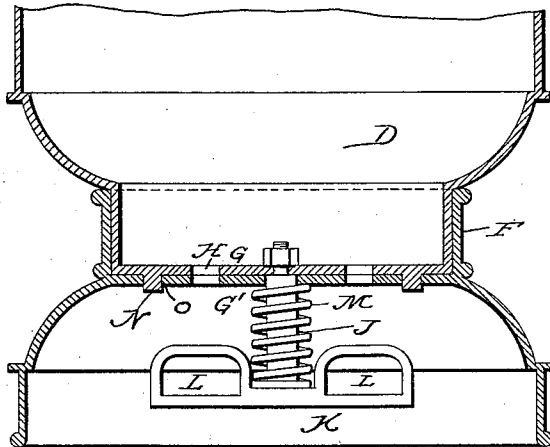

FIG. 5.

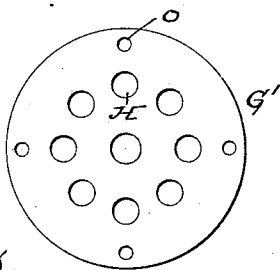
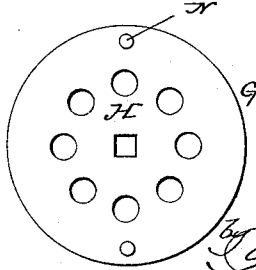

FIG. 6.



Witnesses

Edw. S. Swall, Jr.
May E. Moore

Peter Gray
Inventor

John A. Moore
Attorney

UNITED STATES PATENT OFFICE.

PETER GRAY, OF CAMBRIDGE, MASSACHUSETTS.

SIGNAL-LANTERN.

SPECIFICATION forming part of Letters Patent No. 521,162, dated June 12, 1894.

Application filed November 11, 1893. Serial No. 490,695. (No model.)

To all whom it may concern:

Be it known that I, PETER GRAY, a citizen of the United States, residing at Cambridge, in the county of Middlesex and State of Massachusetts, have invented certain new and useful Improvements in Signal-Lanterns; and I do declare the following to be a full, clear, and exact description of the invention, such as will enable others skilled in the art to which it appertains to make and use the same.

My invention relates to improvements in signal lanterns, and has special reference to a railway lantern usually placed upon the rear coach of a train, and the primary object of my invention is the provision of simple, durable and inexpensive devices which will permit of the ready and rapid changing of the lenses according to the signal to be displayed and which improvements will be thoroughly practical.

To attain the desired object the invention consists of a signal lantern embodying novel features of construction and combination of parts substantially as disclosed herein.

In order that the details of construction and the operation and advantages of my invention may be readily understood and appreciated I have illustrated in the accompanying drawings a signal lantern constructed according to my invention.

Figure 1 represents a side elevation of a signal lantern embodying my improvements with a portion of the lantern broken away to disclose details. Fig. 2 represents a bottom plan view thereof. Fig. 3 represents a detail sectional view on an enlarged scale to more clearly show the devices for adjusting the lantern to display the different colors, the adjusting devices being in the position they assume when the lantern is locked at the proper place to display the desired color. Fig. 4 represents a similar view the disks being separated and the studs thereon being disengaged from the openings to permit the turning of the lantern to the desired position. Figs. 5 and 6 represent detail views of the abutting disks which have the locking studs and the openings to receive said studs.

Referring by letter to the drawings in which similar letters of reference denote corresponding parts in the several views: A designates the bracket or support which is fas-

tened generally upon the rear of the last coach of the train and receives the arm B, having the band C, which encircles the lower part of the lantern D. From this construction it will be seen that the lantern fits snugly in the band but the upper portion carrying the bull's eyes or lenses E, can be rotated in the cup shaped lower portion F, to display any one of the lenses, and the abutting disks G and G' are provided with aligning openings H to allow the ingress of air. Passing centrally through the disks is the stem J, having at its lower end the cross-piece K, provided with finger loops L, and around the stem and bearing against the cross-piece and disk G' is the coiled spring M, the purpose of which is to draw down upon the upper disk G and cause the depending studs N, thereon to positively engage the openings O, in the disk G' and thus lock the upper portion of the lantern at each quarter turn to display any one of the various lenses according to the character of the signal to be displayed.

From this construction it will be understood that to adjust the lantern to display the different lenses it is only necessary to grasp the cross-piece with the fingers in the loops thereof and push the stem upward which breaks the connection of the disks by disengaging the studs on the upper disk from the openings on the lower disk and by giving the cross-piece a quarter turn the lantern is moved the proper distance to display the desired lens, and it will be seen that I provide simple, durable, inexpensive and practical means to accomplish the desired objects.

I claim—

1. In a signal lantern, the combination of the upper section carrying the lenses and having the circular bottom or disk provided with depending lugs, the lower section having the circular disk abutting against the disk of the upper section and having openings to receive the lugs of the upper disk, the depending stem connected to the upper disk for elevating the upper section and revolving it said stem having a handle, and a spring bearing against the lower disk and the handle of the stem for preventing accidental detachment of the locking devices, in the manner described.

2. In a signal lantern, the combination of

the stationary section having the abutting disk provided with openings, the adjustable section carrying the lenses and having the abutting disk provided with depending studs, 5 for engaging the openings of the stationary section, and a handle connected with the adjustable section for moving the section to display the lenses.

3. In a signal lantern, the combination of 10 the upper section carrying the lenses having the flat bottom or disk, the lower section connected thereto, and having the flat disk resting or abutting against the other disk, openings in the abutting portion of the lower stationary section, a stem connected to the upper 15 movable section and having a handle for rotating the upper section, and studs on the upper section for engaging the openings of

the lower stationary section to retain the lantern at the proper adjustment. 20

4. In a signal lantern, the combination of the upper section carrying the lenses and having the disk, the lower section having the abutting disk, studs on the upper disk and openings on the lower disk to receive the 25 studs, a stem having the upper end connected to the upper disk and having the operating handle or cross-piece to move the upper portion of the lantern, and the spring coiled around the stem, for the purpose described. 30

In testimony whereof I affix my signature in presence of two witnesses.

PETER GRAY.

Witnesses:

R. T. CHAMBERLIN,
GEORGE M. GRAY.