

No. 632,814.

Patented Sept. 12, 1899.

J. D. HAY & B. M. BULLOCK.

GAS ENGINE.

(Application filed Apr. 21, 1899.)

(No Model.)

3 Sheets—Sheet 1.

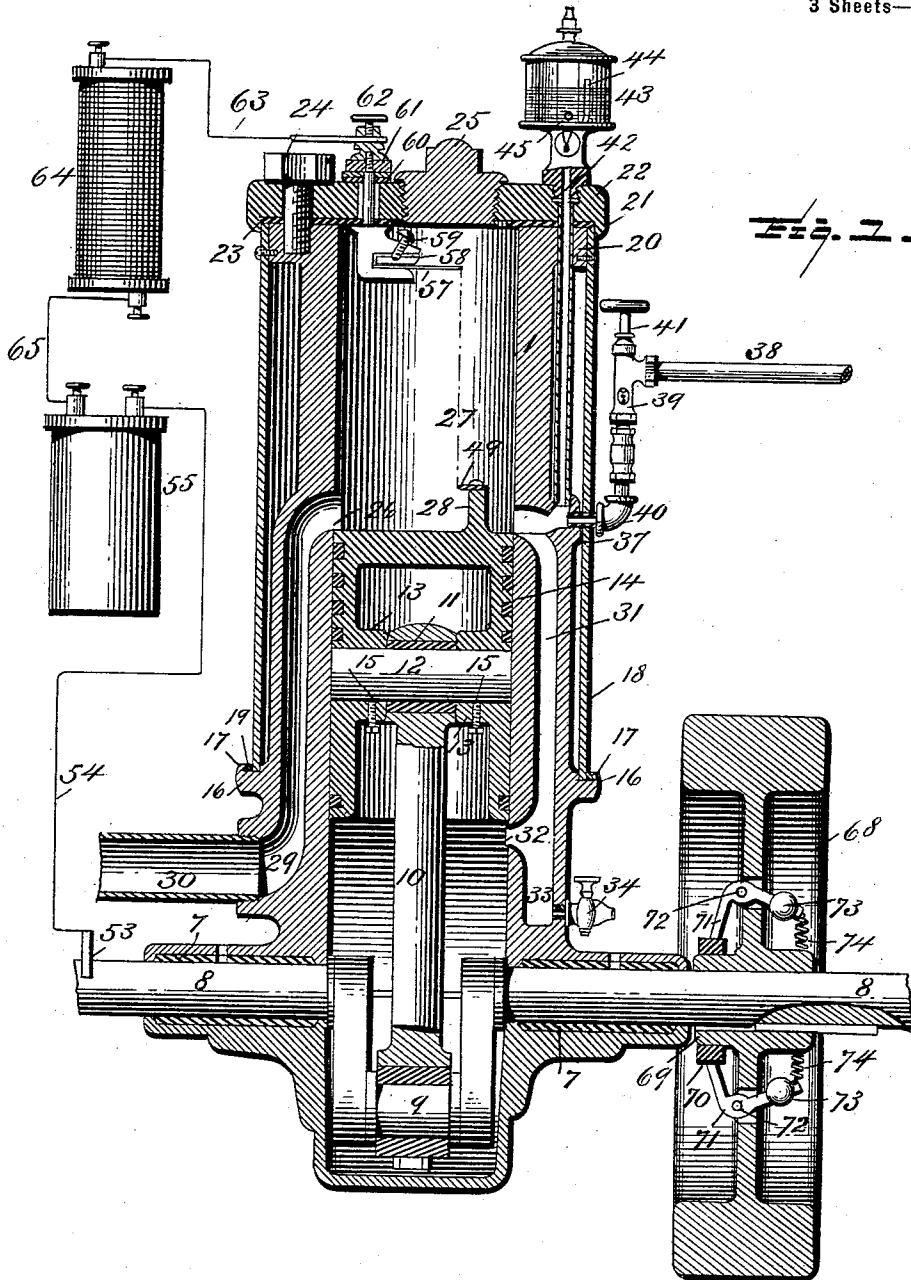

Witnesses
L. C. Hills.
F. C. Berry

Inventors
John D. Hay,
Berton M. Bullock.
By Cha. W. Fowler,
Attorney

No. 632,814.

Patented Sept. 12, 1899.

J. D. HAY & B. M. BULLOCK.
GAS ENGINE.

(Application filed Apr. 21, 1899.)

(No Model.)

3 Sheets—Sheet 2.

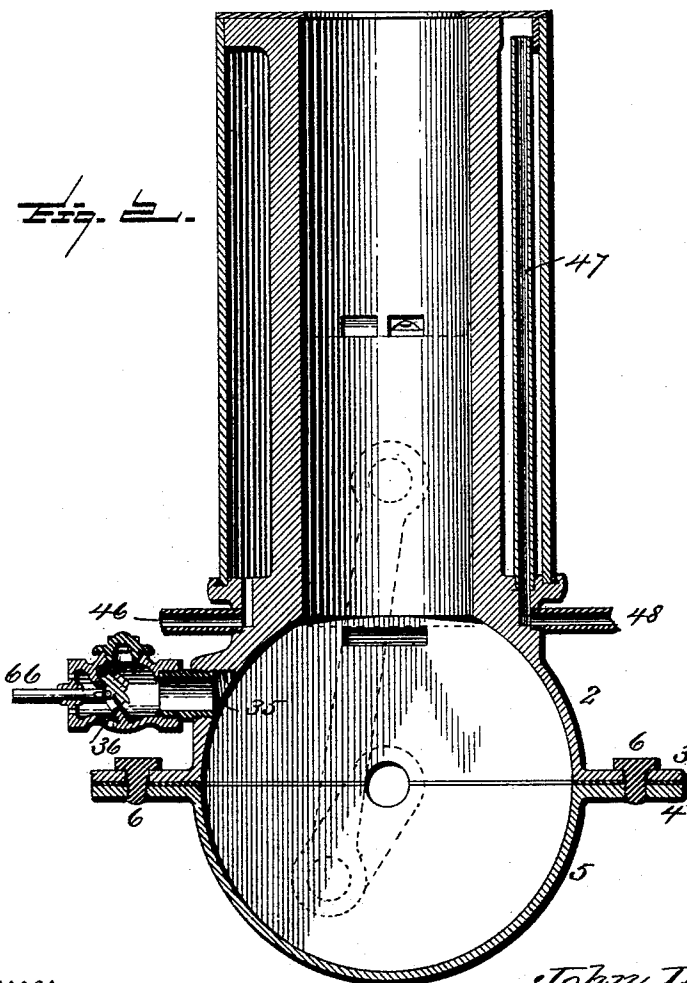
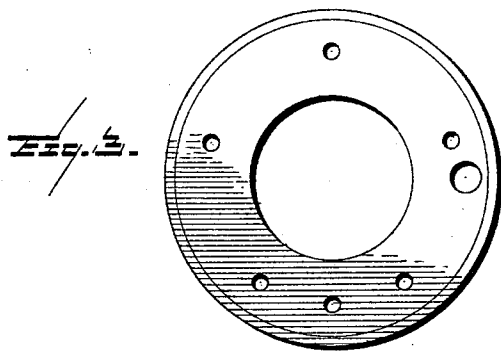

Witnesses
L. C. Mills
F. C. Perry

Inventors
John D. Hay
Berton M. Bullock
By *Chas. H. Fowler*
Attorney

No. 632,814.

Patented Sept. 12, 1899.

J. D. HAY & B. M. BULLOCK.
GAS ENGINE.

(Application filed Apr. 21, 1899.)

(No Model.)

3 Sheets—Sheet 3.

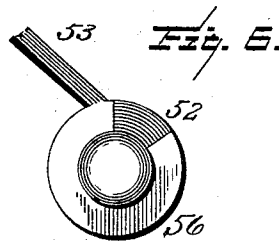
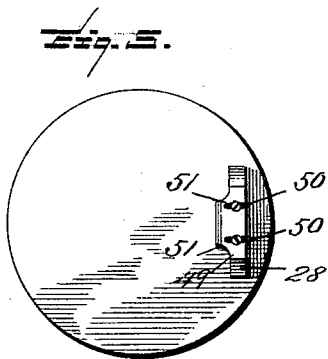
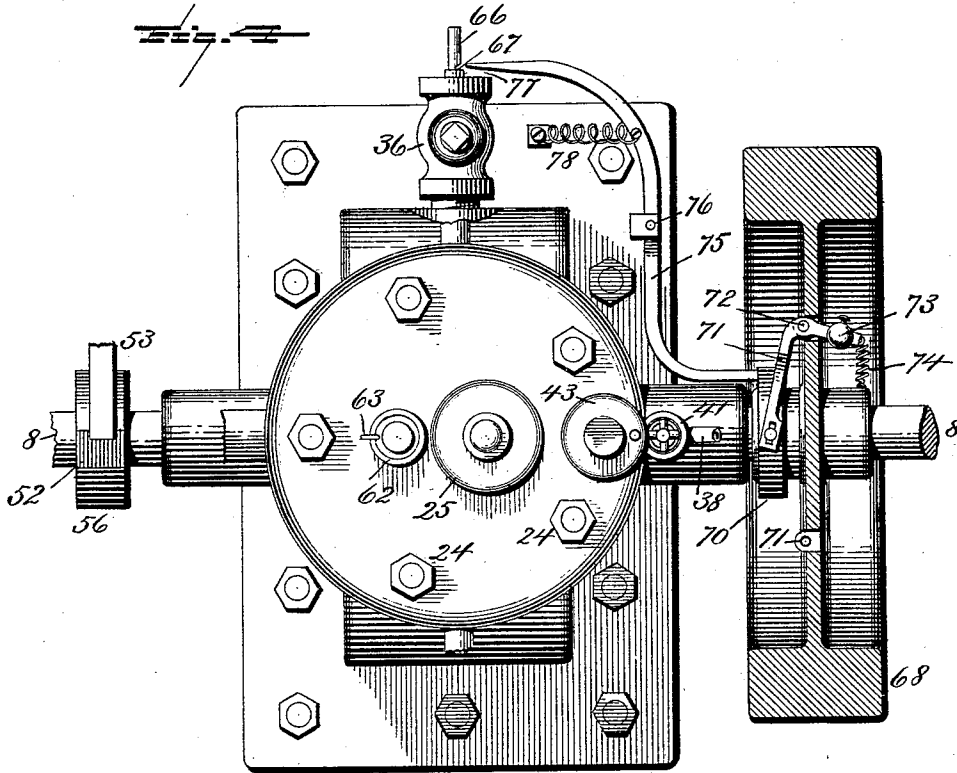

Witnesses
L. C. Mills.
F. O. Perry.

Inventors
John D. Hay.
Berton M. Bullock.
By *Cha. H. Fowler.*
Attorney

UNITED STATES PATENT OFFICE.

JOHN D. HAY AND BERTON M. BULLOCK, OF PLYMOUTH, INDIANA.

GAS-ENGINE.

SPECIFICATION forming part of Letters Patent No. 632,814, dated September 12, 1899.

Application filed April 21, 1899. Serial No. 713,873. (No model.)

To all whom it may concern:

Be it known that we, JOHN D. HAY and BERTON M. BULLOCK, citizens of the United States, residing at Plymouth, in the county of Marshall and State of Indiana, have invented certain new and useful Improvements in Gas-Engines; and we do hereby declare that the following is a full, clear, and exact description of the same, reference being had to the annexed drawings, making a part of this specification, and to the figures of reference marked thereon.

The present invention has relation to certain new and useful improvements in gas-engines, and particularly to that class of engines in which an explosion takes place once in each revolution of the crank-shaft and in which the explosive charge is made from air mixed with gas or air mixed with gasolene or other hydrocarbon oil, the charge being prepared in the casing which incloses the crank-shaft.

The object of the invention is to improve the above-mentioned class of gas-engines in the several details of construction, whereby lightness and compactness are secured and the same rendered accessible in all its parts, economical in its operation, and comparatively inexpensive, which object is attained by the construction substantially as shown in the drawings and hereinafter described and claimed.

Figure 1 of the drawings is a vertical section taken through the axis of the cylinder and the crank-shaft; Fig. 2, a vertical section through the axis of the cylinder, taken at right angles to the crank-shaft; Fig. 3, a plan view of the upper end of the cylinder; Fig. 4, a plan view of the engine, a portion thereof being shown in section; Fig. 5, a plan view of the upper surface of the piston, and Fig. 6 a detail view showing the commutator on the crank-shaft and the brush for operating the electric igniter.

In the accompanying drawings, 1 represents the cylinder-body, which is swelled, preferably, to a semicircular form at 2 and is provided with a flange 3 to join it to a semicircular base 5 at flange 4, said flanges 3 and 4 being united with bolts 6. The two semicircular parts form a crank-casing and are bushed with antifricition metal or brasses 7

for the crank-shaft 8, the crank-pin 9 having journaled thereto the piston-rod 10, and the upper end of said piston-rod is journaled in brasses or metalline bearings 11 about the wrist-pin 12. The wrist-pin 12 is secured in lugs 13 of piston 14 by means of set-screws 15, said piston being provided with packing-rings above and below the wrist-pin, as shown in Fig. 1 of the drawings. The cylinder is provided with a flange 16, having a recess 17, in which fits the cylinder-casing 18, the same being tightly calked into said recess by means of a lead ring 19. The upper end of the cylinder is provided with a flange 20, around which the casing 18 snugly fits and against which it is clamped by the flange 21 on the lower surface of the cylinder-head 22. Between the cylinder-head 22 and the cylinder-flange 20 there is a suitable packing or gasket 23, and the head and flange are secured together by bolts 24, the cylinder-head being further provided with a threaded opening stopped by a screw-plug 25, the purpose of which will be hereinafter described. The cylinder is provided with an exhaust-port 26, which is uncovered by the piston as it approaches the lower dead-center, and an inlet-port 27, opposite to the exhaust-port, which is also uncovered by the piston when at the lower dead-center. The exhaust-port 26 is of greater width than the inlet-port 27, so that it will be opened by the piston slightly in advance of the port 27. The piston 14 is provided with a deflector 28 for the purpose of deflecting the entering charge upwardly to sweep out the exhaust-gases and to prevent it from mixing therewith and passing out at the exhaust-port, which port enters a passage 29, cored out in the cylinder, and provides an escape to the atmosphere through an exhaust-pipe 30. The port 27 leads into a passage 31, which is also cored out in the cylinder-wall and which opens at 32 into the crank-casing, the lower end of the passage 31 having a pocket 33, into which a drain-cock 34 is fitted, the purpose of which will appear hereinafter. The crank-casing is provided with another port 35, which leads to the atmosphere through an inwardly-opening check-valve 36. In passage 31 the cylinder-wall is caused to project to form a ledge 37, which is directly opposite the inlet-port

27. A gasolene-pipe 38 supplies the explosive fluid to a sight-feed 39, which connects just above the ledge 37 with the passage 31 at 40, the flow of oil to the sight-feed being regulated by means of a needle-valve 41, and inwardly-opening check-valve being provided, as indicated at 41'. A pipe 42 extends downwardly to just above the ledge 37 and conveys lubricating-oil from an oil-cup 43, the passage in said pipe extending above the oil in the oil-cup, as indicated at 44, so as to permit the air-pressure in port 31 to enter above the oil, the oil being thus forced downward through sight-feed 45 to the ledge 37 and passes with the charge into the cylinder to lubricate the piston. The space between the casing 18 and the cylinder 1 constitutes a water-jacket into which water enters through a pipe 46 and flows about the cylinder, and becoming hot then escapes through a pipe 47, which extends upwardly in the jacket to near the cylinder-head and then passes out through the pipe 48.

To provide for the ignition of the charge in the cylinder, the piston is provided with an electrode at the top of the deflector 28, said electrode consisting of a plate 49 with slots 50, through which set-screws 51 pass to adjustably secure the electrode to the deflector. The electrode is an electric circuit through the metal of the piston, cylinder, shaft, and a commutator 52 on said shaft with brush 53, wire 54 with battery 55, or other source of electric current. The commutator is so placed on the shaft as to break circuit just after first spark is formed, said commutator consisting of a metal segment 52, set into a ring 56, of an insulating material, secured to the shaft. The electrode 49 makes contact with another electrode 57, located within the cylinder and preferably secured in the cylinder-head, as shown in Fig. 1 of the drawings.

The electrode 57 consists of a flexible spring-plate which is secured in a holder 58 by means of an adjusting-screw 59. The holder 58 extends through the cylinder-head, as shown in Fig. 1 of the drawings, and is provided with a packing, as indicated at 60, which insulates it from the cylinder-head and cylinder, and is further provided with washers 61 and a binding-screw 62, which connect by wire 63 with a spark-coil 64, said coil connecting with battery 55 by wire 65, thus completing the circuit.

To provide for the governing of the air-inlet to the crank-casing, the check-valve 36 is provided with a stem 66, which has a notch 67.

On the crank-shaft 8 is keyed a fly-wheel 68, on the hub of which is a sliding sleeve 70, and upon this sleeve are two bell-crank levers 71, connected thereto and pivoted to the web of the fly-wheel. The outer ends of the bell-crank levers are provided with centrifugal weights 73, which are drawn inwardly toward the shaft by means of springs 74. The sleeve 70 is in contact with a lever 75, which is

curved as shown, and which is pivoted at 76, the outer end of said lever, as indicated at 77, being sharp to fit into notch 67 of valve-stem 66 at certain times, and a spring 78 holds the lever firmly against the sleeve.

Having now clearly described the various parts of the engine and their construction, the operation thereof is as follows: The needle-valve 41 being open the gasolene will flow to the ledge 37, and the fly-wheel being turned by hand the piston will rise and draw in air past check-valve 36. On the downstroke of the piston the check-valve closes and the imprisoned air is compressed and passes up the passage 31, and as the piston overruns the inlet-port 27 the air, which has absorbed the gasolene, rushes into the cylinder, carrying with it in an atomized form the gasolene and lubricating-oil from ledge 37 and is deflected upward by the deflector 28, and sweeps out the products of combustion through exhaust-port 26, which opens slightly in advance of inlet-port 27. After the new charge has entered the cylinder and the piston in continuing its upward stroke has closed both ports 26 and 27 the charge is compressed until the piston reaches its upper dead-point, and in so doing the electrode 49 trips by the flexible electrode 57 and again trips by it as the piston starts on its downward stroke. An electric spark passes between the electrodes at this point, as the commutator-brush 53 is at this time on the metallic segment 52 and the charge is fired. As the piston approaches its lower dead-point the exhaust-port 26 is first opened and the burned gases escape from the cylinder, the inlet-port being next opened and the operation repeated. Should the engine speed rise above the desired normal, the centrifugal weights 73 will fly out against the resistance of springs 74 and the sleeve 70 will move along the hub of the fly-wheel and move lever 75, so that its point 77 will enter the notch 67 of valve-stem 66, thereby holding the valve 36 closed. While the engine is thus above its normal speed no more air can enter the crank-casing and no new charges will be formed, and consequently no explosions will take place until the speed again drops to normal. Any gasolene or lubricating-oil which may not be vaporized or carried into the cylinder will drop down into pocket 33, whence it may be removed at times through the cock 34.

The operation of the electrodes may be observed by removing the screw-cap 25, and they may be properly adjusted either by set-screws 51 or 59.

The crank-casing is partially filled with oil for the lubrication of the crank-pin, the passage 32 communicating with the crank-casing to admit the lubricating-oil freed from sediment flowing into the crank-chamber for this purpose.

Having now fully described our invention, what we claim as new, and desire to secure by Letters Patent, is—

1. In a gas-engine, the combination of a cylinder, piston, inlet and exhaust ports in said cylinder so located as to be opened by the piston when near the extremity of its out-
 5 stroke, a closed crank-casing, an air-inlet check-valve in said casing, a passage leading from the casing to the cylinder inlet-port, a ledge in said passage, a fuel-supply opening upon said ledge, with a lubricating-oil supply
 10 also opening upon said ledge, whereby the lubricating-oil is forced into the cylinder with the charge, substantially as and for the purpose set forth.

2. In a gas-engine, the combination of a cylinder, an inlet in said cylinder located so as to be uncovered by the engine-piston when near the extremity of its outstroke, a closed crank-casing, an inlet check-valve in said casing, a passage leading from the casing to the cylinder inlet-port, a ledge in said passage, a fuel-supply opening in said passage or on said ledge, with a duct opening upon said ledge which leads to a lubricator-cup above the level of the oil therein, whereby
 25 the pressure in the passage is communicated above the oil-space in the oil-cup and the oil is forced into the cylinder with the charge, substantially as and for the purpose specified.

3. In a gas-engine, the combination of a cylinder provided with inlet and exhaust ports which are opened by the engine-piston when near the extremity of its outstroke, a casing inclosing the lower part of the piston and the engine-shaft, an air-inlet check-valve in said casing, a passage leading from the casing to the cylinder inlet-port, with a speed-governor for holding the check-valve closed when the engine's speed is above the normal, substantially as and for the purpose described.

4. In a gas-engine, the combination of a cylinder, a piston therein, a casing connected with the cylinder which incloses the cylinder below the piston, an air-inlet check-valve therein, an inlet-port in said cylinder, a passage leading from the casing to the inlet-port, a speed-governor operated by the engine and mechanism operated by said governor for holding the check-valve closed when the speed of the engine is above the normal, substantially as and for the purpose set forth.

5. In a gas-engine, the combination of a cylinder, a piston therein, a crank-shaft operated by the piston, a casing inclosing the piston and crank-shaft, an air-inlet check-valve opening into said casing, a speed-governor operated by the engine with means operated by

said governor for keeping said check-valve closed when the speed of the engine is above normal, substantially as and for the purpose specified.

6. In a gas-engine, the combination of a cylinder, a piston therein, a crank-shaft operated by said piston, a casing inclosing the piston and the crank-shaft, a passage leading from said casing to an inlet-port in said cylinder a check-valve in said casing opening inwardly, a governor operated by said crank-shaft, a stem on the check-valve provided with a notch, with means connected with the governor for entering said notch to hold the valve in a closed position when the speed of the engine is above the normal, substantially as and for the purpose described.

7. In a gas-engine, the combination of a cylinder, a piston therein, a crank-shaft operated by said piston, a casing inclosing the piston and crank-shaft, a passage leading from said casing to an inlet-port in said cylinder a check-valve opening into the casing, a fly-wheel on the shaft, a pair of spring-actuated weighted levers, pivoted to the fly-wheel, a sliding sleeve on the shaft operated by the levers under the influence of centrifugal force, a lever having one end pressed against the side of said sleeve by a spring and the opposite end so located as to enter a notch in the stem of said valve to hold the valve closed when the engine speed is above the normal, substantially as and for the purpose set forth.

8. In a gas-engine, the combination of a cylinder, a piston therein, a crank-shaft operated by said piston, a casing inclosing the crank-shaft and piston, an inlet-valve in said casing, an inlet-port in said cylinder, a passage leading from the casing to the inlet-port, a fuel-supply located in said passage, with a pocket at the lower part of the passage for the collection of fuel and a lubricator and passage leading into the crank-casing, whereby the lubricating-oil freed from sediment can flow into said casing to lubricate the crank-pin, substantially as and for the purpose specified.

In testimony that we claim the above we have hereunto subscribed our names in the presence of two witnesses.

JOHN D. HAY.
 BERTON M. BULLOCK.

Witnesses:

SAMUEL PARKER,
 K. F. BROOKE.