

April 10, 1951

H. A. REINHART

2,548,063

CYLINDER TRANSPORTING DEVICE FOR INDUSTRIAL TRUCKS

Filed Sept. 22, 1947

2 Sheets-Sheet 1

Fig. 1.

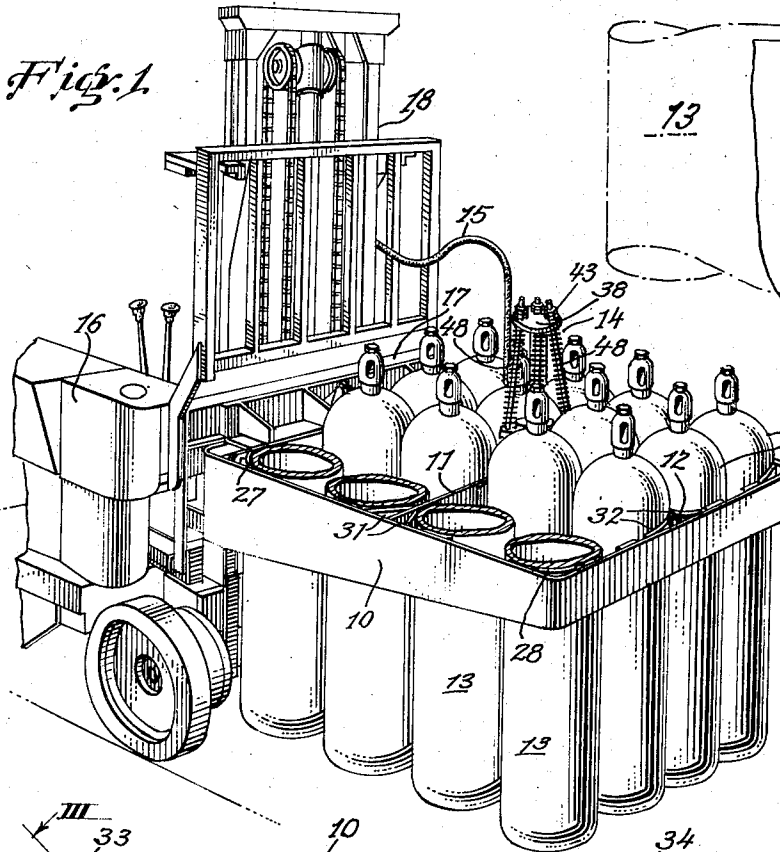

Fig. 3.

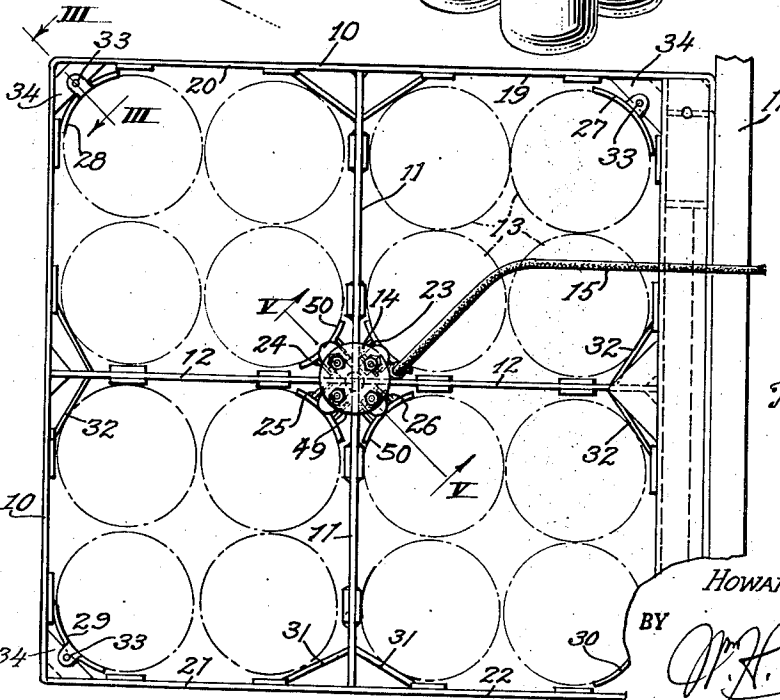
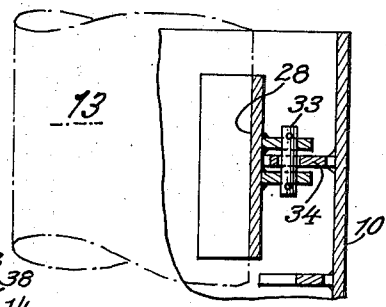

Fig. 2.

INVENTOR.
HOWARD A. REINHART.

BY *W. H. Robinson*

ATTORNEY

April 10, 1951

H. A. REINHART

2,548,063

CYLINDER TRANSPORTING DEVICE FOR INDUSTRIAL TRUCKS

Filed Sept. 22, 1947

2 Sheets-Sheet 2

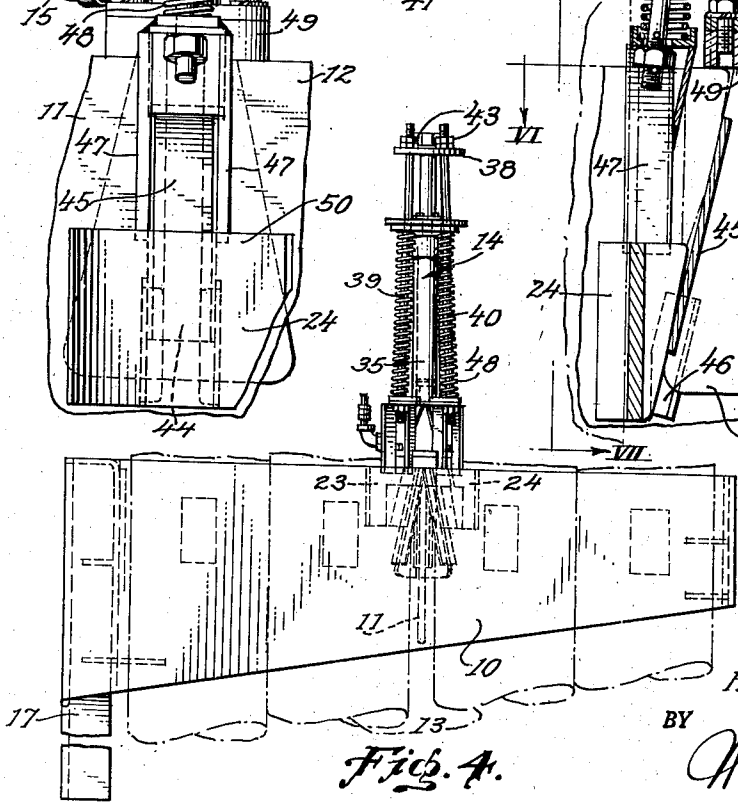
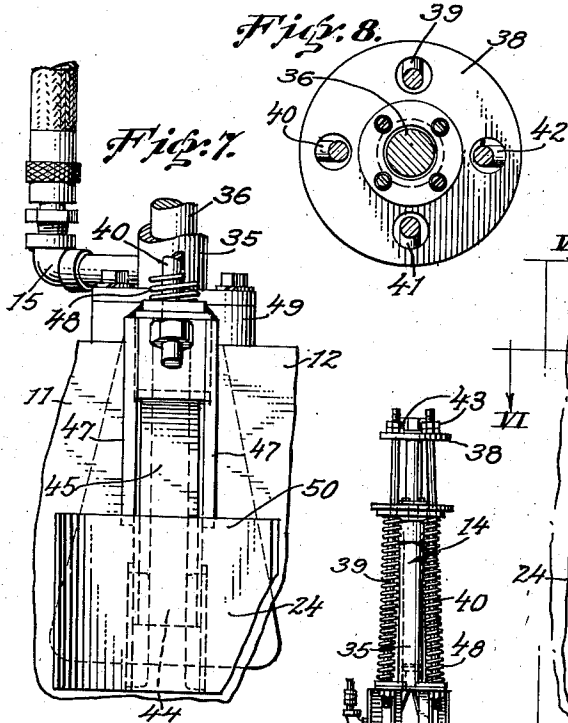
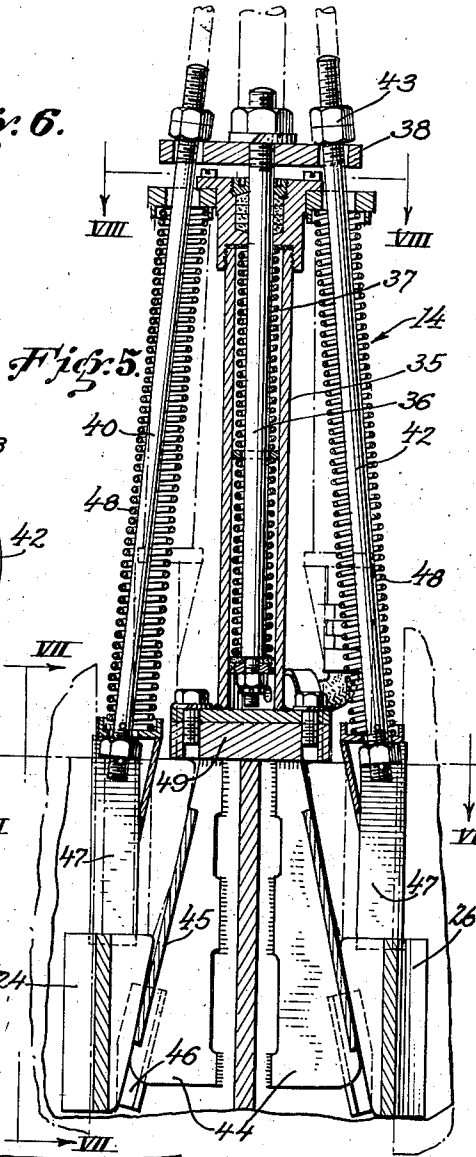
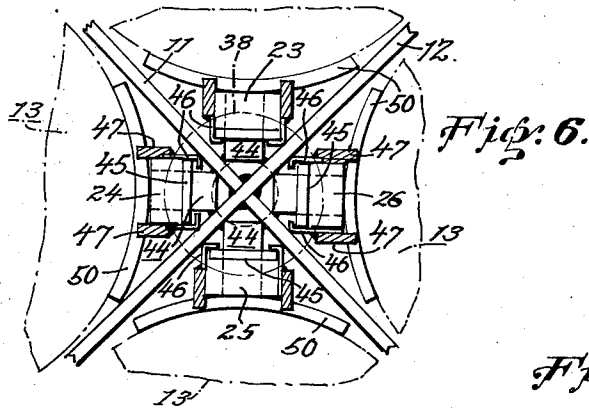

INVENTOR.
HOWARD A. REINHART.

BY
W. H. Robinson
ATTORNEY.

UNITED STATES PATENT OFFICE

2,548,063

CYLINDER TRANSPORTING DEVICE FOR INDUSTRIAL TRUCKS

Howard A. Reinhart, San Francisco, Calif., assignor, by mesne assignments, to Tray-Hart, Inc., a corporation of New Jersey, % George D. Cherry, First National Bank of Jersey City, Jersey City, N. J.

Application September 22, 1947, Serial No. 775,497

8 Claims. (Cl. 214—65)

1

2

My present invention relates broadly to article handling apparatus and more particularly to an improved attachment for power driven vehicles of the so-called lift type by which the plurality of cylindrical gas containers and other similar articles may be handled in nested groups and transported from one location to another in a convenient and efficient manner.

An object of the invention is to provide an apparatus or attachment for a power driven vehicle by which a plurality of articles may be simultaneously picked up and transported as a unit from one location to another in a new, novel and practical manner.

Another object of the invention is to provide an apparatus for handling a nested plurality of pressure gas bottles or like cylindrical containers, which may be carried upon a conventional lift truck and in which the gas bottles or cylindrical containers are handled in nested groups and held so that they may be picked up as a unit for transporting to a distant point where they are subsequently unloaded in the same nested relation.

Another object of the invention is to provide a novel form of vertically movable frame having a compartment or compartments into which several articles to be transported are held by a novel wedging means which becomes operative when the frame is moved with respect to the articles to be transported and which is releasable only when the articles disposed therein are supported freely of the frame.

A further object of the invention is to provide a means for transporting a plurality of like articles from one position to another in which a horizontally disposed frame having a compartment or a plurality of compartments with gravity responsive gripping means, is mounted to extend outwardly at the front of a lift truck so that it may be lowered over a nested group of articles which are then engaged by the gripping means so that upon a subsequent upward movement of the frame the gripping means will become operative and cause the articles to be picked up as a group for transportation to a distant point.

Other objects and advantages of the invention will be in part evident to those skilled in the art and in part pointed out in the following description taken in connection with the accompanying drawings wherein there are shown by way of illustration and not of limitation a preferred embodiment of the invention.

In the drawings;

Figure 1 is a perspective view showing a portion of a conventional lift truck with my improved apparatus mounted thereupon,

Figure 2 is a plan view of the device as shown in Figure 1 of the drawings,

Figure 3 is an enlarged sectional view taken along line III—III of Figure 2 looking in direction of arrows,

Figure 4 is a fragmentary side view of the device as shown in Figure 1 of the drawings,

Figure 5 is an enlarged vertical section taken along line V—V of Figure 2 looking in direction of arrows and showing details of the invention,

Figure 6 is a fragmentary sectional view taken along line VI—VI of Figure 4 looking in direction of arrows,

Figure 7 shows further details of construction, and

Figure 8 is a sectional view taken along line VIII—VIII of Figure 4 of the drawings.

In a co-pending application filed by me and Mr. Arthur M. Selvey, as joint inventors, entitled "Apparatus for transporting cylindrical containers and the like" Serial No. 704,518, filed October 19, 1946 and now Patent No. 2,528,783 granted November 7, 1950, there is shown and claimed a cylindrical container transporting apparatus upon which the present invention is an improvement. As distinguished from the apparatus of the aforesaid application the present invention contemplates the gripping and handling of a plurality of cylindrical articles as a group and in which gripping elements are arranged in such a manner that a single operating mechanism will serve to simultaneously control the article gripping and releasing action of the device. More specifically my present device is particularly adapted for the transportation of small diameter containers and is arranged to carry at least four cylindrical articles in each of its compartments. A further advantage of this device is that the number of operative wedging elements is reduced to a minimum as only a single wedge or gripping member is required for each group of four cylindrical articles.

Like the above identified co-pending application, my present device contemplates a horizontally disposed frame-like member 10 having transversely extending partitions 11 and 12 which intersect at a right angle to each other and form four compartments into each one of which four gas bottles, or like cylindrical containers 13, may be disposed. At the center of the frame 10 and extending upwardly from the intersecting

3

point of the partitions 11 and 12 there is a fluid pressure responsive means 14 that will be described in detail hereinafter and which is adapted to simultaneously control and render inoperative four wedging members one each of which operate within one of the four compartments of the frame 10. In this particular showing the fluid pressure responsive means 14 has a fluid pressure supply conduit 15 that connects with a source of fluid pressure carried by a truck 16 of the conventional fork lift type and at its rear side the frame 10 is adapted to be secured to a vertically movable frame member 17 which forms a part of an elevating structure 18 such as is customarily provided upon trucks of the so-called fork lift type.

As is more clearly shown in Figure 2 of the drawings, the four compartments of the frame 10, here respectively identified by the numerals 19, 20, 21 and 22 are symmetrically arranged with respect to each other so that the rectangular frame 10 together with the transversely extending partitions 11 and 12 provide compartments of a size sufficient to accommodate four cylindrical containers. In this manner a total of sixteen cylindrical articles or containers may be picked up and transported in a single operation. The fluid pressure responsive means 14 is here adapted to control the operation of four vertically movable wedging members 23, 24, 25 and 26 which are respectively located in the innermost corners of the compartments 19, 20, 21 and 22 and at the outermost corners of these four compartments there are oppositely arranged pressure resisting pads 27, 28, 29 and 30 which respectively cooperate with the wedging members 23, 24, 25 and 26 to form a grip upon the adjacent wall of a cylindrical article or container positioned there against. As an additional means to insure a firm gripping of a group of four cylindrical articles or containers in each of the compartments 19, 20, 21 and 22 the remaining corners of these compartments are provided with angularly disposed guide plates 31 and 32 which will serve to maintain a close nested relation between the several cylindrical containers in each of the compartments when the associated wedging means is in operation.

As is more clearly shown in Figure 3 of the drawings each of the pressure resisting pads 27, 28, 29 and 30 are pivotally mounted so as to rock about a vertically extending pin 33 which is carried by a bracket 34 welded in the outermost corners of the frame 10. In this arrangement these pads may rock from one side to the other and thus provide for an equalization of the pressures exerted upon two adjacent cylindrical articles or containers when the opposed and cooperating wedging members come into operation.

As shown in Figure 4 of the drawings, the frame 10 is arranged to extend outwardly in front of the elevating mechanism 18 of the power driven truck 16. This showing also indicates that the fluid pressure operating mechanism 14 is positioned outwardly from the truck and centrally of the four compartments formed by the partitions 11 and 12 which extend at right angles within the limits of the frame 10.

The details of construction of the operating mechanism will now be described in connection with the remaining figures of the drawings. As shown in Figure 5, the fluid responsive operating mechanism 14 includes a fluid pressure cylinder 35 within which there is a vertically operating

4

piston 36 that moves in response to fluid pressure admitted through the conduit 15 at the lower end of the cylinder 35. To assist and insure against a sticking and a return stroke of the piston 36 when the fluid pressure is removed I provide a compression spring arrangement 37. At the upper end of the piston 36 there is a disc-like member 38 through which four rods, designated by the numerals 39, 40, 41 and 42, extend and carry abutments in the form of locked nuts 43. At their lower ends these rods 39, 40, 41 and 42 are connected respectively to the four wedging members 23, 24, 25 and 26 so that when the piston 36 is moved upwardly by fluid under pressure these wedging members will be raised with respect to the frame 10 and the partitions 11 and 12 provided therein. In this particular instance the wedging members 23, 24, 25 and 26 are guided into wedging relation within the cylindrical articles or containers within the compartments of the frame 10 by means of angularly disposed bearing plates 44 which are disposed in the adjacent corners of the four compartments. These bearing plates each have a flanged face along their outer surfaces that is formed by the welding of transversely extending plates 45. A description on the mounting of one of these wedging members should serve to explain the construction. For example, the wedge 24 is here shown as having a right angled clip 46 welded along each of its sides which will overhang the flanges formed by the plate 45 to thus retain it in sliding relation with its associated bearing plate 44. Extending upwardly from the wedge 24 there is a connecting member 47 to which the lower end of the rod 40 is connected. In this instance the rods 39, 40, 41 and 42 are each shown as extending through coiled compression springs 48 which will operate to return the wedging members into their operative positions when the fluid pressure operating mechanism 14 is not energized. At this point it should be stated that these springs 48 may be dispensed with whenever the weight of the wedging members is such that the force of gravity alone is sufficient to return the wedging members 23, 24, 25 and 26 to their lowermost positions. In any event, these compression springs 48 will be of only sufficient strength to insure a full return of the wedges 23, 24 and 25 to their lowermost and operating positions. The springs 48 are not necessarily required to provide the wedging force as a wedging effect sufficient to produce a gripping of the articles within the compartments of the frame 10 will be created by the weight of the cylindrical articles as the frame 10 is raised with respect thereto. In this manner it will be seen that the gripping and releasing of articles for transportation by the frame 10 is controlled by the use of a single fluid pressure cylinder 35 and with a single wedging member in each of the four compartments.

At this point and before going on to the remaining figures of the drawing, it will be noted that the fluid pressure cylinder 35 with its operating piston 36 is secured at its lower end to a plate 49 that is welded at the upper edges of the transversely extending partitions 11 and 12 at the point where they intersect or, in other words, centrally of the frame 10.

As shown in Figure 7 of the drawings each of the wedging members 23, 24, 25 and 26 are provided with an arcuate surface forming plate 50 which will have a curvature conforming substantially to the curvature of the outer surface of the

5

cylindrical containers or other articles to be transported by the device here disclosed. In some instances these arcuate plates 50 may be provided with a facing of rubber or leather in order to provide for an increased co-efficient of friction which would further serve to insure a downward wedging action by the several wedging members when the frame 10 with its inclined wedge supporting surfaces 45 is moved upwardly relative to the containers over which it may have been previously lowered.

From the above it will be readily apparent that whenever the frame 10 is lowered over a nested group of cylindrical containers or like articles sufficient to fill one or more of the compartments formed by the partitions 11 and 12 the associated wedging members 23, 24, 25 and/or 26 will by virtue of its contact with the wall of an adjacent container or cylindrical member be caused to wedge themselves against said containers and thus create a clamping force which will cause the engaged group of cylindrical containers or articles to be carried upwardly and raised from any supporting surface by the frame 10 as the elevating mechanism 13 of the truck 16 is set in operation. Then when the cylindrical containers or other articles are thus picked up and have been brought to proper elevation they may be carried as a group to any other desired location. Now to release and discharge the cylindrical articles, thus transported, from the frame 10, it will only be necessary to lower the frame 10 until the bottoms of the containers or other articles have engaged with a suitable independent supporting surface. When this occurs the wedging members 23, 24, 25 and 26 may be rendered inoperative by the admission of a fluid under pressure to the cylinder 35 of the fluid pressure responsive means 14. This will permit the frame 10 to be moved upward and free of the articles just transported. In this connection, while the frame 10 is here illustrated and described as having four compartments each capable of carrying four of the cylindrical containers or other articles it will be understood that the frame 10 may be provided with a single compartment or a greater or less number of compartments depending upon the use to which the invention is to be put. It will also be understood that where the number of articles less than the total capacity of the frame are to be transported from one point to another it will be necessary to nest these articles so that at least four of the articles will be positioned in one or the other of the compartments formed by the partitions 11 and 12. In other words, my device will operate equally well with any number of cylindrical containers or other articles provided the grouping of at least four will be disposed in each of the occupied compartments.

While I have, for the sake of clearness and in order to disclose the invention so that the same can be readily understood, described and illustrated specific devices and arrangements, I desire to have it understood that this invention is not limited to the specific means disclosed, but may be embodied in other ways that will suggest themselves to persons skilled in the art. It is believed that this invention is new and all such changes as come within the scope of the appended claims are to be considered as part of this invention.

Having thus described my invention, what I claim and desire to secure by Letters Patent is:

1. In an article handling device for transport-

6

ing a plurality of vertically disposed cylindrical articles from one point to another, the combination of a horizontally disposed outer frame having intersecting partitions forming rectangular compartments into each of which the upper ends of a plurality of nested cylindrical articles may extend, said compartments being open at their bottoms to permit said frame to be lowered over a nest of articles to be transported and with a plurality of said articles in each of said compartments, a gravity actuated wedging member disposed in one corner of each of said compartments adapted upon a relative upward movement of said frame to engage one of said articles, and means at the other corners of each of said compartments adapted to cooperate with said wedging member and cause said nested articles to be gripped as a unit when said frame is raised relative thereto.

2. In an article handling device for transporting a plurality of vertically disposed cylindrical articles from one point to another, the combination of a horizontally disposed frame having partitions forming a plurality of rectangular compartments into which the upper ends of a number of nested cylindrical articles may extend, said frame being adapted and arranged for raising and lowering over and with respect to a nest of articles to be transported with a plurality of said articles in each of said compartments, a gravity actuated wedging member member disposed in one corner of each of said compartments adapted upon a relative upward movement of said frame to engage one of said articles and cause said nested articles to be gripped for transportation as a unit as said frame is raised, and means for rendering said wedging member inoperative when said articles are positioned upon an independent supporting surface.

3. In a cylindrical container handling device of the character described, the combination of a horizontally extending rectangular frame having vertical partitions forming four open bottom compartments therein each capable of accommodating four vertically disposed cylindrical containers when grouped in contact with each other, means at the three outer corners of each of said four compartments against which the outermost of said containers are adapted to engage, and a gravity actuated wedging member arranged in the innermost corner of each of said compartments adapted when said frame is moved upwardly relative to said cylindrical containers to clamp four of said containers in each of said compartments.

4. In a cylinder handling device of the character described, the combination of a horizontally disposed rectangular frame having vertical partitions forming four compartments each capable of accommodating a plurality of vertically standing cylindrical articles, means within the three outer corners of each of said compartments against which the outermost of said articles are adapted to engage, a gravity actuated wedging member arranged in the remaining corner of each of said compartments adapted to engage one of said articles in each of said compartments when said frame is moved upwardly relative thereto, and an operating means common to all of said wedging means adapted when energized to render said wedging means inoperative and permit free relative upward movement of frame when said cylindrical containers are brought to rest upon an independent supporting surface.

5. In a cylindrical container handling device

7

of the character described, the combination of a horizontally disposed rectangular frame having a compartment capable of accommodating a plurality of vertically standing cylindrical containers when nested together, a gravity actuated wedging member arranged in one corner of said compartment adapted to clamp said containers in said compartment when said frame is moved upwardly relative thereto, a pivotally mounted pad arranged in said compartment diagonally opposite said gravity actuated wedging member against which one of said cylindrical containers is adapted to engage, and guide means disposed in the remaining corners of said compartment tending to guide said containers into clamped engagement with each other and toward said pivotally mounted pad as said gravity actuated wedging member operates.

6. In a cylindrical container handling device of the character described, the combination of a horizontally disposed rectangular frame having a compartment capable of accommodating a plurality of vertically standing cylindrical containers when nested together, a gravity actuated wedging member arranged in one corner of said compartment adapted to clamp said containers in said compartment when said frame is moved upwardly relative thereto, a pivotally mounted pad arranged in said compartment diagonally opposite said gravity actuated wedging member against which one of said cylindrical containers is adapted to engage, guide means disposed in the remaining corners of said compartment tending to guide said containers into clamped engagement with each other as said gravity actuated wedging member operates, and a fluid pressure operating means adapted when energized to render said wedging means inoperative and permit free relative upward movement of said frame independently of said cylindrical containers when said cylinders are brought to rest upon an under supporting surface.

7. In a compartmented frame having intersecting partitions forming adjoining compartments, a gravity responsive wedging member disposed in the adjacent corners of each of said adjoining compartments for gripping articles disposed

8

therein, a single fluid pressure cylinder having an operating piston means disposed centrally of said wedging members, and an operating connection between said piston means and each of said wedging members adapted to simultaneously raise said wedging members against the action of gravity when fluid under pressure is admitted to said cylinder to thereby render said wedging member inoperative and thus release any articles held in said compartments when said articles are positioned upon an independent supporting surface.

8. In a compartmented frame having intersecting partitions forming four adjoining compartments, a downwardly operating wedging member disposed in the adjacent corners of each of said adjoining compartments for gripping articles disposed therein, a single fluid pressure cylinder having an upwardly operating piston disposed centrally of said wedging members, and means forming an operating connection between said piston and each of said wedging members adapted when fluid under pressure is admitted to said cylinder to raise said wedging members with respect to said frame and thus permit said frame to be lowered over articles to be transported and also release any articles held in said compartments by said wedging means when said articles are positioned upon an independent supporting surface.

HOWARD A. REINHART.

REFERENCES CITED

The following references are of record in the file of this patent:

UNITED STATES PATENTS

Number	Name	Date
1,555,379	Moody -----	Sept. 29, 1925
40 1,797,494	Campbell -----	Mar. 24, 1931
1,900,569	Lederer -----	Mar. 7, 1933
1,929,447	Remde -----	Oct. 10, 1933
2,138,498	McMillan -----	Nov. 29, 1938
2,178,369	Dunham -----	Oct. 31, 1939
45 2,317,064	Josephian -----	Apr. 20, 1943
2,340,812	Koob -----	Feb. 1, 1944
2,437,806	Dempster -----	Mar. 16, 1948