

J. S. Raymond,

Cutting Shingles.

Patented Aug. 15, 1837.

No 356.

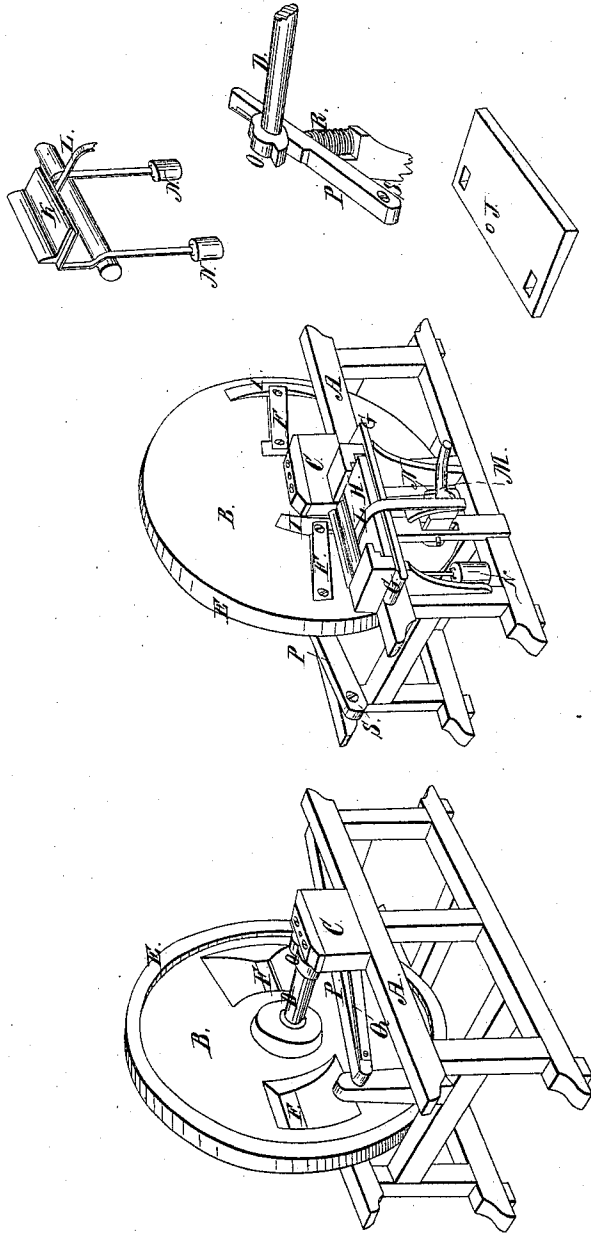

UNITED STATES PATENT OFFICE.

JOSEPH S. RAYMOND, OF LODI, NEW YORK.

MACHINE FOR CUTTING SHINGLES AND SIDING FROM STEAMED TIMBER.

Specification of Letters Patent No. 356, dated August 15, 1837.

To all whom it may concern:

Be it known that I, JOSEPH S. RAYMOND, of Lodi, Cattaraugus county, in the State of New York, have invented a new and improved machine for cutting, making, and manufacturing shingles and siding from steamed or boiled timber or otherwise; and I do hereby declare the following to be a full and exact description of the same.

10 Construct a substantial frame A from eight to ten feet long, about five feet wide and three and a half feet high to support a revolving wheel B and other parts of the machinery. On each side of said frame in
15 the center, place pillars or bolsters C C to support the gudgeons or ends of the axle or shaft D of said wheel. The wheel may be constructed of wood or metal or both about eight feet diameter or in proportion to the
20 length of shingles to be cut, with a rim or flange E on the extremity or periphery of the wheel of sufficient width for a band or strap to drive or propel the same, said wheel to be fixed near one end of said shaft just
25 inside of said frame. On the face or side of the wheel next the frame are affixed two or more knives F F opposite each other of sufficient length for the purposes required. One end of each knife to be fastened near
30 the rim on the face of the wheel and the other end extending toward the axis but varying from a direct line either above or below and to be varied at pleasure or as the timber or case may require to be fastened
35 firm the same as the outer end thereby producing a drawing or oblique blow in cutting the timber.

40 The knives are to be fixed at a proper distance from the face of the wheel so as to give the shingles their proper thickness and to change the butt or thick end of the shingles alternately. Attached to said frame

and making part of the same is a table or form a directly opposite of the knife when cutting and at a right angle with the face of
45 the wheel and about one foot below the horizontal of the axis. On the top of this table is a vibrating plane H which has its motion by means of the guards or cams I I on the
50 wheel at each end of the knives and which may be kept to the face of the wheel by springs, weights or a pivot or pin J in the center. This vibrating plane is intended to support the timber at the edge of the knife
55 when cutting. On this plane is a follower K drawn back by a strap L fastened to a lever M under the table and by weights N N or springs is made to draw the block to the wheel as fast as is requisite for cutting.
60 On the other and opposite end of the shaft are affixed cams O operating on the lever P to which a knife Q is fastened in a similar position to those on the face of the wheel and may be raised by weights or springs R
65 one end of the lever being fastened by a pin S or otherwise so as to produce a joint, and the other end left to take motion by the action of the cam.

The invention claimed by me the said J. S. RAYMOND and which I desire to secure
70 by Letters Patent consists—

1. In the reversed position of the knives, with the guards or cams I, I on their ends by which the vibrating plane H is shifted.

2. The follower K.

3. The lever and knife for edging, in combination all as set forth in the description.

No claim is made to the making of shingles by placing knives on the face of the wheel.

J. S. RAYMOND.

Witnesses:

WM. P. ELLIOT,
ALFRED DUVALL.