

PCT

WORLD INTELLECTUAL PROPERTY ORGANIZATION



WO 9603938A1

INTERNATIONAL APPLICATION PUBLISHED UNDER THE PATENT COOPERATION TREATY (PCT)

(51) International Patent Classification ⁶ : A61F 2/24	A1	(1)	(43) International Publication Date: 15 February 1996 (15.02.96)
--	----	-----	--

(21) International Application Number: PCT/US95/08419
(22) International Filing Date: 5 July 1995 (05.07.95)
(30) Priority Data: 08/283,059 29 July 1994 (29.07.94) US
(71) Applicant: BAXTER INTERNATIONAL INC. [US/US]; One Baxter Parkway, Deerfield, IL 60015-4633 (US).
(72) Inventors: CARPENTIER, Alexandre; 44, rue Cortambert, F-75116 Paris (FR). CARPENTIER, Alain, F.; 44, rue Cortambert, F-75116 Paris (FR).
(74) Agents: SUN, Raymond et al.; P.O. Box 15210, Irvine, CA 92713-5210 (US).

(81) Designated States: CA, JP, European patent (AT, BE, CH, DE, DK, ES, FR, GB, GR, IE, IT, LU, MC, NL, PT, SE).
Published
*With international search report.
Before the expiration of the time limit for amending the claims and to be republished in the event of the receipt of amendments.*

(54) Title: ANNULOPLASTY DISTENSIBLE RING

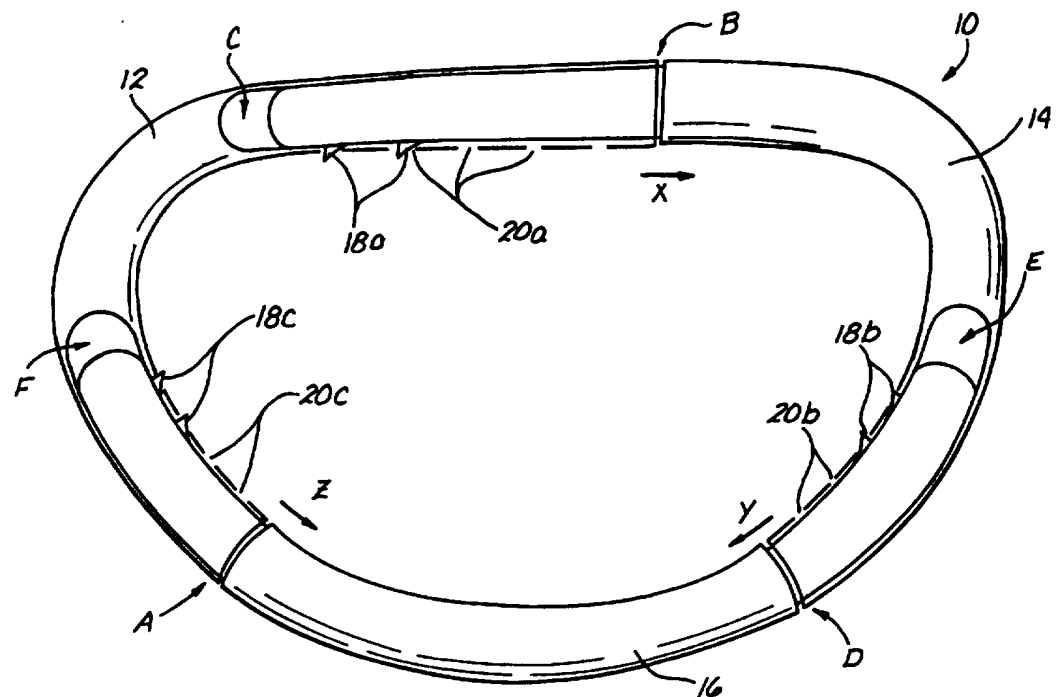

(57) Abstract
The distensible annuloplasty ring which may be enlarged, in situ, by application of dilatory pressure by way of a balloon or other dilating apparatus. The distensible annuloplasty ring of the invention is usable in pediatric patients whose growth, subsequent to surgical implantation of the ring, will necessitate subsequent enlargement of the ring to accommodate growth of the annulus. The invention includes a transluminal and/or transeptal method for post-implantation enlargement of the annuloplasty ring via catheter.

FOR THE PURPOSES OF INFORMATION ONLY

Codes used to identify States party to the PCT on the front pages of pamphlets publishing international applications under the PCT.

AT	Austria	GB	United Kingdom	MR	Mauritania
AU	Australia	GE	Georgia	MW	Malawi
BB	Barbados	GN	Guinea	NE	Niger
BE	Belgium	GR	Greece	NL	Netherlands
BF	Burkina Faso	HU	Hungary	NO	Norway
BG	Bulgaria	IE	Ireland	NZ	New Zealand
BJ	Benin	IT	Italy	PL	Poland
BR	Brazil	JP	Japan	PT	Portugal
BY	Belarus	KE	Kenya	RO	Romania
CA	Canada	KG	Kyrgyzstan	RU	Russian Federation
CF	Central African Republic	KP	Democratic People's Republic of Korea	SD	Sudan
CG	Congo	KR	Republic of Korea	SE	Sweden
CH	Switzerland	KZ	Kazakhstan	SI	Slovenia
CI	Côte d'Ivoire	LI	Liechtenstein	SK	Slovakia
CM	Cameroon	LK	Sri Lanka	SN	Senegal
CN	China	LU	Luxembourg	TD	Chad
CS	Czechoslovakia	LV	Latvia	TG	Togo
CZ	Czech Republic	MC	Monaco	TJ	Tajikistan
DE	Germany	MD	Republic of Moldova	TT	Trinidad and Tobago
DK	Denmark	MG	Madagascar	UA	Ukraine
ES	Spain	ML	Mali	US	United States of America
FI	Finland	MN	Mongolia	UZ	Uzbekistan
FR	France			VN	Viet Nam
GA	Gabon				

ANNULOPLASTY DISTENSIBLE RING

Field of the Invention

The present invention relates generally to medical devices, and more particularly to annuloplasty ring useable for surgical correction of certain disorders of the atrio-ventricular (i.e., mitral and tricuspid) valves of the human heart.

Background of the Invention

In many patients who suffer from disfunction of the mitral and/of tricuspid valve(s) of the heart, surgical repair of the valve (i.e. "valvuloplasty") is a desirable alternative to valve replacement. One specific group of patients who are typically candidates for such surgery are children who suffer from congenital atrioventricular septal defect (AVSD).

Remodelling of the valve annulus (i.e. "annuloplasty") is central to many reconstructive valvuloplasty procedures. Such remodelling of the valve annulus may be accomplished by implantation of a prosthetic ring (i.e. "annuloplasty ring") to stabilize the annulus and to correct or prevent valvular insufficiency which may result from defect or disfunction of the valve annulus.

The prior art has included numerous annuloplasty rings, such as those described in United States Patents Nos: 4,042,979 (Angell); 4,290,151 (Massana); 4,898,446 (Reed); 4,602,911 (Ahmadi et al.); 5,061,277 (Carpentier et al.); and 5,201,880 (Wright et al.), as well as International Patent Publication WO 91/17721 and Foreign Patent Publication SU197710.

One problem associated with the annuloplasty rings of the prior art is that, when such annuloplasty rings are implanted into children (such as pediatric patients with

AVSD) the subsequent growth of the patient may render the annuloplasty ring too small for its intended function. Thus, follow-up surgery may be necessary to replace the originally implanted annuloplasty ring with a larger ring
5 suitable for the then-current size of the patient.

Although some of the annuloplasty rings of the prior art have incorporated means for adjusting the size of the ring at the time of implantation, applicant is aware of no prior art annuloplasty ring which is constructed and
10 equipped for post-implantation size adjustment, in situ, to accommodate changes in annular size due to growth of the patient.

Summary of the Invention

15 The present invention provides a distensible annuloplasty ring which may be expanded, in situ, by way of a transvascularly and/or transeptally positionable valve expansion apparatus.

In accordance with a presently preferred embodiment of
20 the invention, the annuloplasty ring may be made up of a plurality of separate segments or leaves which are slidably or movably secured to one another to form a ring having the desired configuration of the mitral or tricuspid valve annulus. When dilatory or outward pressure is exerted
25 against the inner surface of the ring, as may be accomplished by way of a radially expandable member (e.g., a balloon or expandable wire cage) introduced within the annulus of the remodeled valve, such pressure will cause the segments or leaves to slide or distend relative to one
30 another. Such sliding or distention of the segments or leaves will expand the ring to a larger annular size.

It is preferable that the individual segments or leaves which form the ring incorporate locator lugs and notches, or other suitable registry apparatus or frictional
35 locator apparatus, for controlling the amount of distension

which results from each application of dilatory pressure, and for preventing the segments or leaves from inadvertently slipping or moving relative to one another.

The ring may be covered by a stretchable or distensible sheath to prevent blood from entering into and/or stagnating in the spaces between the articulating surfaces of the individual segments or leaves. Also, a stretchable or distensible suture ring, formed of needle-penetrable material such as Dacron mesh, is mounted on the ring to facilitate suturing-in-place of the ring at the time of implantation.

In accordance with an alternative embodiment of the invention, the annuloplasty ring may be formed of a nonelastic polymer or other distensible material which will remain distended after the application of outward dilatory pressure has been terminated.

Still further in accordance with the invention, there is provided a method for performing remodelling annuloplasty of an atrioventricular valve, with a subsequent transluminal and/or transeptal procedure for enlargement of the a annuloplasty ring to accommodate growth of the patient.

Further objects and advantages of the invention will become apparent to those skilled in the art, upon reading of the following Detailed Description of the Preferred Embodiments and consideration of the accompanying drawings.

Brief Description of the Drawings

Figure 1 is a partial perspective view of a first embodiment of the adjustable annuloplasty ring of the present invention.

Figure 2 is a partial cut-away perspective view of a second embodiment of the adjustable annuloplasty ring of the present invention.

Figure 3 is a reduced perspective view of a third embodiment of the adjustable annuloplasty ring of the present invention.

Figure 3a is an enlarged, cut away perspective view, of a portion of the annuloplasty ring of Figure 3.

Figure 4 is a cut-away illustration of a human heart having an adjustable annuloplasty ring of the present invention implanted at the mitral position, and showing the manner in which a dilation apparatus (e.g., a balloon catheter or expandable cage) may be advanced through a catheter, positioned transeptally, and utilized to effect in situ enlargement of the adjustable annuloplasty ring in accordance with the method of the present invention.

Detailed Description of the Preferred Embodiment

The following detailed description and the accompanying drawings are intended to describe and show certain presently preferred embodiments of the invention only, and are not intended to limit the spirit or scope of the invention in any way.

With reference to the drawings, Figures 1-3 show alternative ways of constructing the adjustable ring members 10, 10a and 10b of the present invention. The ring members 10, 10a and 10b shown in Figures 1-3 have a generally "D-shaped" configuration which corresponds to the normal anatomical shape of the mitral valve annulus. It will be appreciated that, if these ring members 10, 10a and 10b were intended for use in remodelling of the tricuspid valve, they would have the generally round configuration of the normal anatomical shape of the tricuspid valve annulus.

The ring member 10 shown in figure 1 comprises first 12, second 14 and third 16 tubular segments. Each segment 12, 14, 16 is joined to the two other segments to form a substantially unitary ring structure. The first segment 12 is tubular in configuration, having open ends A and B into

which the corresponding ends of the second and third segments 14, 16 are inserted. The second segment 14 has a blunt tipped or closed first end C and an open tubular second end D. The third segment 16 has blunt tipped or closed first and second ends E and F, respectively.

The first end C of second segment 14 is inserted into the open second end B of the first segment 12. A series of raised lugs or teeth 18a protrude from one side of the portion of the second segment 14 which inserts into the second end B of the first segment 12. A corresponding series of apertures or detents 20a is formed in the side wall of the first segment 12. The individual teeth 18a snap into and frictionally engage the individual detents 20a, as shown.

Similarly, the first end E of the third segment 16 is inserted into the open second end D of the second segment 14. A series of raised lugs or teeth 18b protrude from one side of the portion of the third segment 16 which inserts into the second end D of the second segment 14. A corresponding series of apertures or detents 20b is formed in the side wall of the second segment 14. The individual teeth 18b snap into and frictionally engage the individual detents 20b, as shown.

Also, the second end F of the third segment 16 is inserted into the open first end A of the first segment 12. A series of raised lugs or teeth 18c protrude from one side of the portion of the third segment 16 which inserts into the first end A of the first segment 12. A corresponding series of apertures or detents 20c is formed in the sidewall of the first segment 12. The individual teeth 18c snap into and frictionally engage the individual detents 20c, as shown.

The individual teeth 18 are configured and constructed such that, when sufficient dilatory pressure is applied to the inner surface of the ring 10, the segments 12, 14, 16

will spread apart and the teeth 18 will be caused to move out of the detents 20 within which they are positioned and will slidably advance and snap into the next available detents in the series, thereby effecting one incremental
5 increase in the annular size of the ring. Further application of additional dilatory pressure will cause the teeth 18 to move to the next available detents 20 in the series, thereby effecting a second incremental increase in size, and so on.

10 Figure 2 shows an alternative ring 10a comprising first and second semi-annular tubular segments 30, 32 which are joined together in end to end fashion, as shown, to form the desired annular configuration of the ring 10a. Rack bars 34, 36 insert into the opposing open ends of the
15 first and second tubular segments 30, 32. Teeth 18 protrude laterally from the portions of each rack bar 34, 36 which insert into the juxtaposed ends of the first and second semi-annular tubular segments 30, 32, as shown. Corresponding apertures or detents 20 are formed in the
20 side walls of the tubular members 30, 32. The individual teeth 18 snap into and frictionally engage the individual detents 20, as shown. As described here above with respect to the embodiment shown in Figure 1, the application of dilatory pressure against the inner surface of the ring 10a
25 wyo cause the semi-annular tubular segments 30, 32 to move apart and the individual teeth 18 will advance to, and seat within, the next available detents 20, thereby causing the size of the ring 10a to increase by a predetermined incremental amount.

30 It will be appreciated that the components which make up the ring member 10 need not necessarily be of tubular configuration as shown in the embodiments of Figures 1 and 2. Indeed, as shown in Figure 3, the ring member 10b may comprise of a plurality of non-tubular arcuate leaves 40,
35 42, 44, 46 assembled in overlapping relation to one another

and contained within a distensible outer sheath 50, as shown.

In any embodiment of the invention, a suture ring 52, formed of material such as Dacron Mesh, is mounted about the periphery of the ring member 10, is mounted about the periphery of the ring member 10, 10a, 10b to facilitate suturing-in-place of the ring member 10, 10a, 10b to surrounding anatomical tissue.

Figure 4 shows a schematic illustration of the human heart having an adjustable annuloplasty ring 10 of the present invention implanted at the mitral position therein. The anatomical structures and major blood vessels of the heart are labeled, on Figure 4, in accordance with the following legend:

- 15 PV Pulmonary Veins
- PA Pulmonary Artery
- RPA Right Pulmonary Artery
- LPA Left Pulmonary Artery
- 20 SVC Superior Vena Cava
- IVC Inferior Vena Cava
- AO Aorta
- RA Right Atrium
- RV Right Ventricle
- 25 LA Left Atrium
- LV Left Ventricle
- IS Interatrial Septum
- AV Aortic Valve Position
- MV Mitral Valve Position
- 30 TrV. Tricuspid Valve
- PuV. Pulmonic Valve

As shown in Figure 4, one method by which the size of the annuloplasty ring 10 may be adjusted is through introduction of a guide catheter 50, via catheterization of the superior vena cava such that the distal end of the catheter is passed through the interatrial septum IS, using known septal penetration technique, and into the left atrium LA. A balloon dilation catheter 52, such as a valvuloplasty catheter of the type commercially available, is then advanced through the lumen of the guide

catheter 50, and positioned such that the balloon 60 of the balloon catheter 52 is within the annulus of the mitral valve MV. Thereafter, the balloon 60 is inflated, as shown, to cause the adjustable annuloplasty ring 10 to expand to a larger annular configuration.

In embodiments, such as those described and shown hereabove in Figures 1-3, it will be appreciated that the balloon 60 may be expanded to a specific diameter which will evoke a single incremental increase (i.e., from one notch to the next) of the mechanical expansion-controlling system of teeth and notches formed in the annuloplasty ring 10.

Similarly, when the annuloplasty ring 10 is implanted at the tricuspid valve TrV it will be desirable to advance the guide catheter 50 through the superior vena cava SVC to a point where the distal end of the guide catheter 50 is positioned within the right atrium RA of the heart. Thereafter, the balloon dilation catheter 52 may be advanced to a point where the distal portion of the balloon catheter 52 extends through the tricuspid valve TrV. Thereafter, the balloon 60 will be dilated so as to expand an annuloplasty ring of the present invention (not shown) when implanted within the tricuspid valve TrV.

It will be appreciated by those skilled in the art that various modifications additions and deletions may be made to the above-described embodiments, without departing from the intended spirit and scope of the invention. Accordingly, it is intended that all such modifications additions and deletions be included within the scope of the following claims.

WHAT IS CLAIMED IS:

1. A distensible annuloplasty ring, having an inner surface defining an annular opening therethrough, said ring comprising:

5 a ring member configured and constructed to distend upon application of dilatory force to the inner surface thereof;

a saturable material disposed on said ring member to facilitate suturing-in-place of said ring member to surrounding anatomical tissue.

10 2. The annuloplasty ring of Claim 1 wherein said ring member comprises:

a plurality of segments movably coupled to one another such that exertion of dilatory pressure against the inner surface of said ring member will cause said segments to move apart from one another, thereby increasing the annular size of the ring member.

15 3. The annuloplasty ring of Claim 2 wherein said segments further comprise:

frictional locator means formed on said segments to control the amount of annular distension that the ring will undergo upon application of dilatory pressure thereto and to prevent inadvertent movement of the segments relative to one another.

25 4. The annuloplasty ring of Claim 1 wherein said ring member is formed of distendable material which retains a distended configuration.

5. The annuloplasty ring of Claim 4 wherein said distendable material is a plastic which is capable of being stretched, and which will retain a stretched configuration after stretching thereof.

30 6. The annuloplasty ring of Claim 1 further comprising:

a substantially impermeable sheath positioned around said ring member to prevent blood from contacting said ring member.

7. The annuloplasty ring of Claim 1 wherein said
5 saturable material comprises Dacron mesh.

8. A method of performing remodeling atrioventricular annuloplasty in a pediatric patient, said method comprising:

a) implanting the distensible annuloplasty ring
10 of Claim 1 within the annulus of an atrioventricular valve;

b) subsequently, when it is desired to increase the annular size of the annuloplasty ring, inserting a dilation apparatus into the valve in which the
15 annuloplasty ring is inflated and utilizing said delation apparatus to distend the annuloplasty ring to a larger annular size.

9. The method of Claim 9 wherein step b) comprises:
20 advancing a catheter transluminally through the vasculature to a point where the distal end of the catheter is positioned adjacent the valve wherein the annuloplasty ring is implanted; and

subsequently advancing said dilation apparatus through said catheter and into its desired position
25 within the valve for subsequent dilation of the annuloplasty ring.

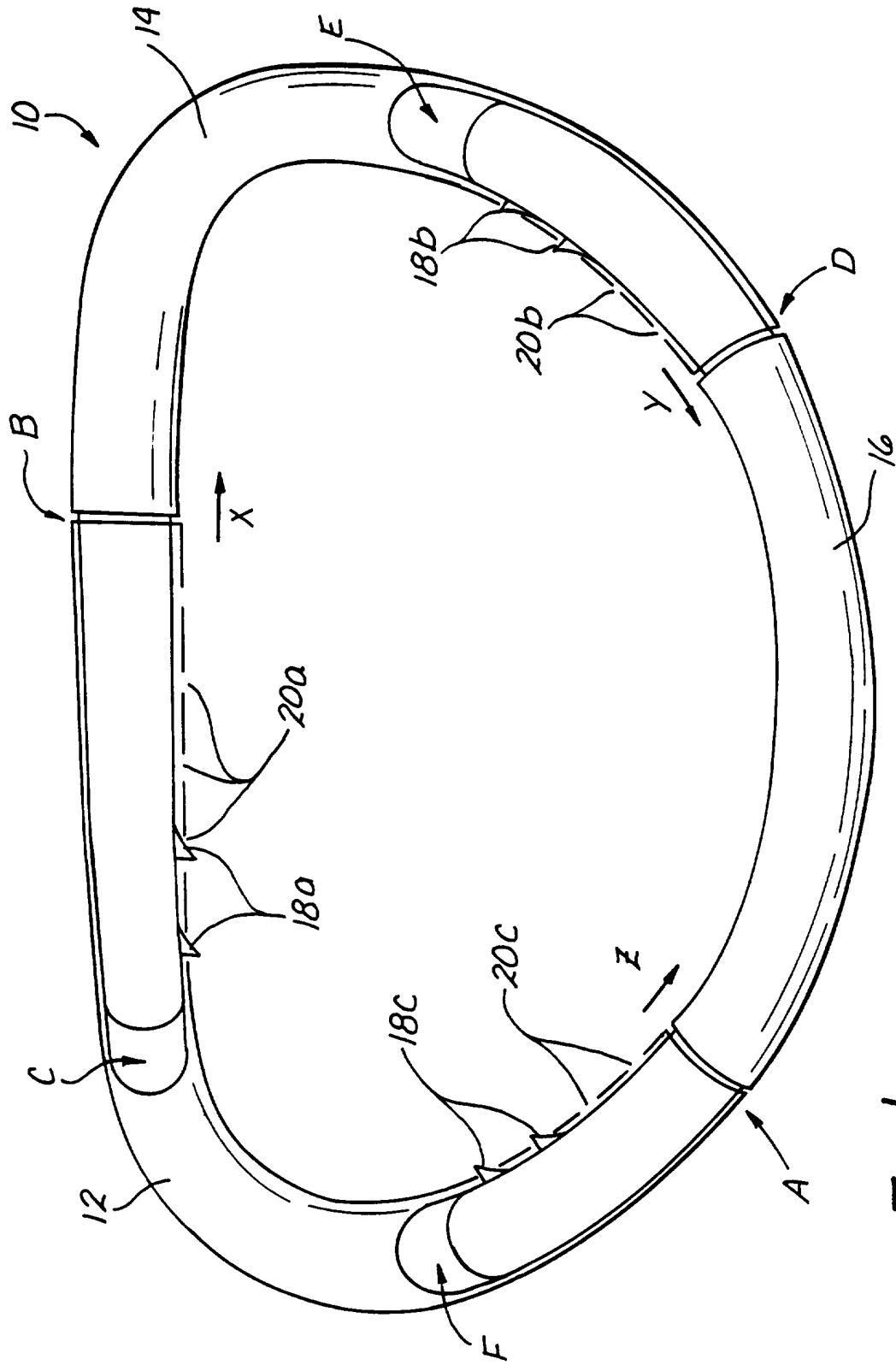

FIG. 1

2 / 4

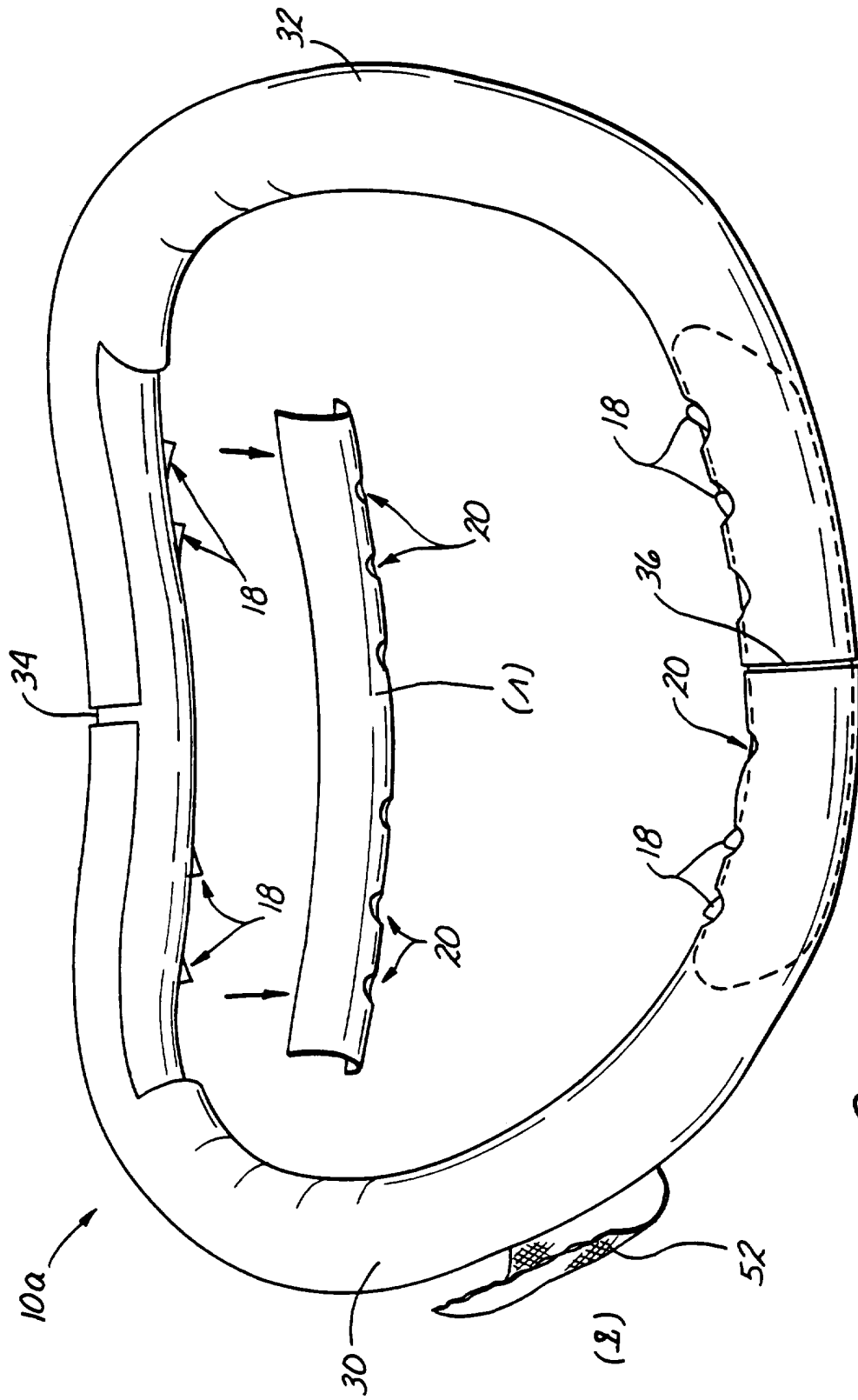

Fig. 2

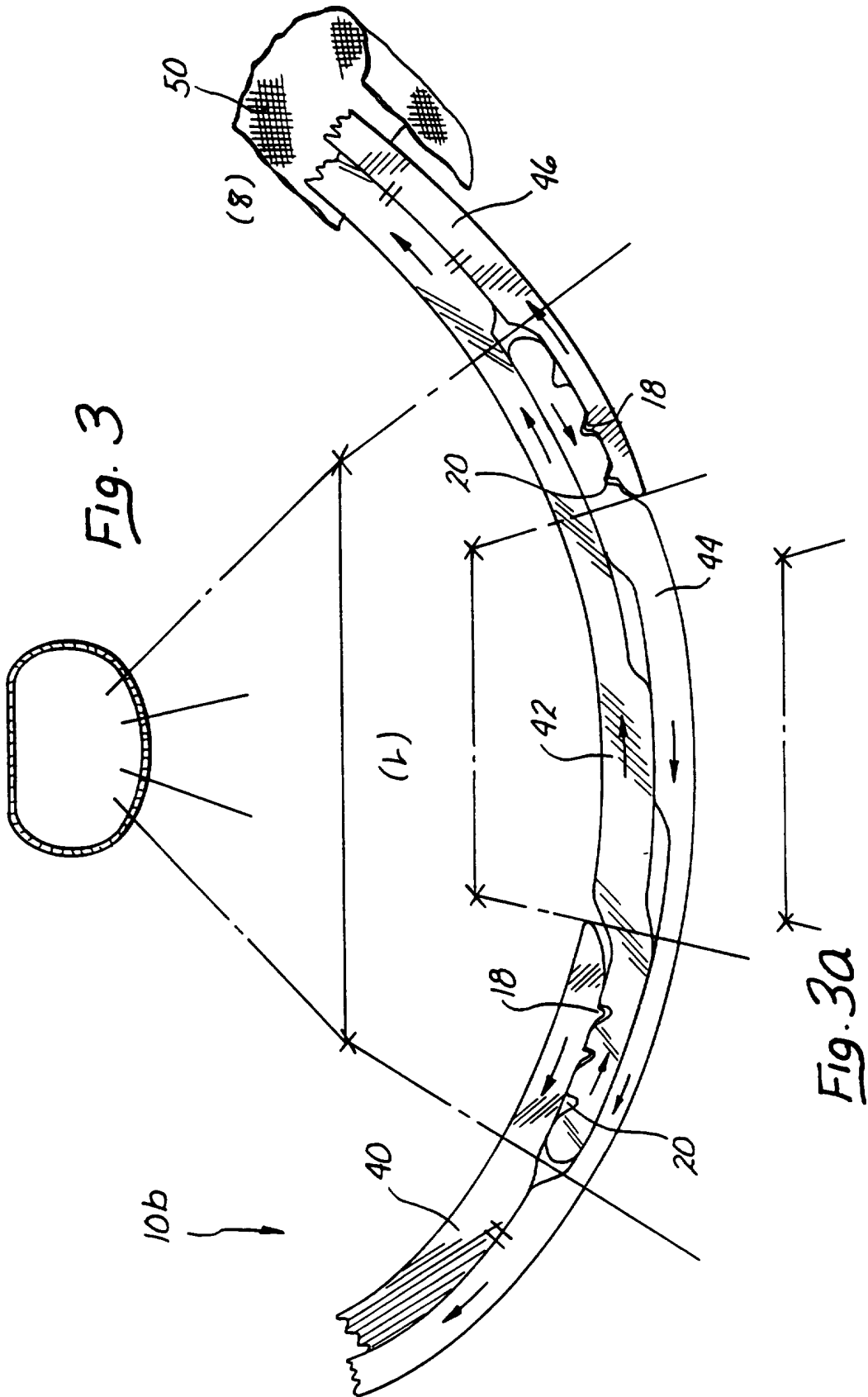

Fig. 3

Fig. 30a

4/4

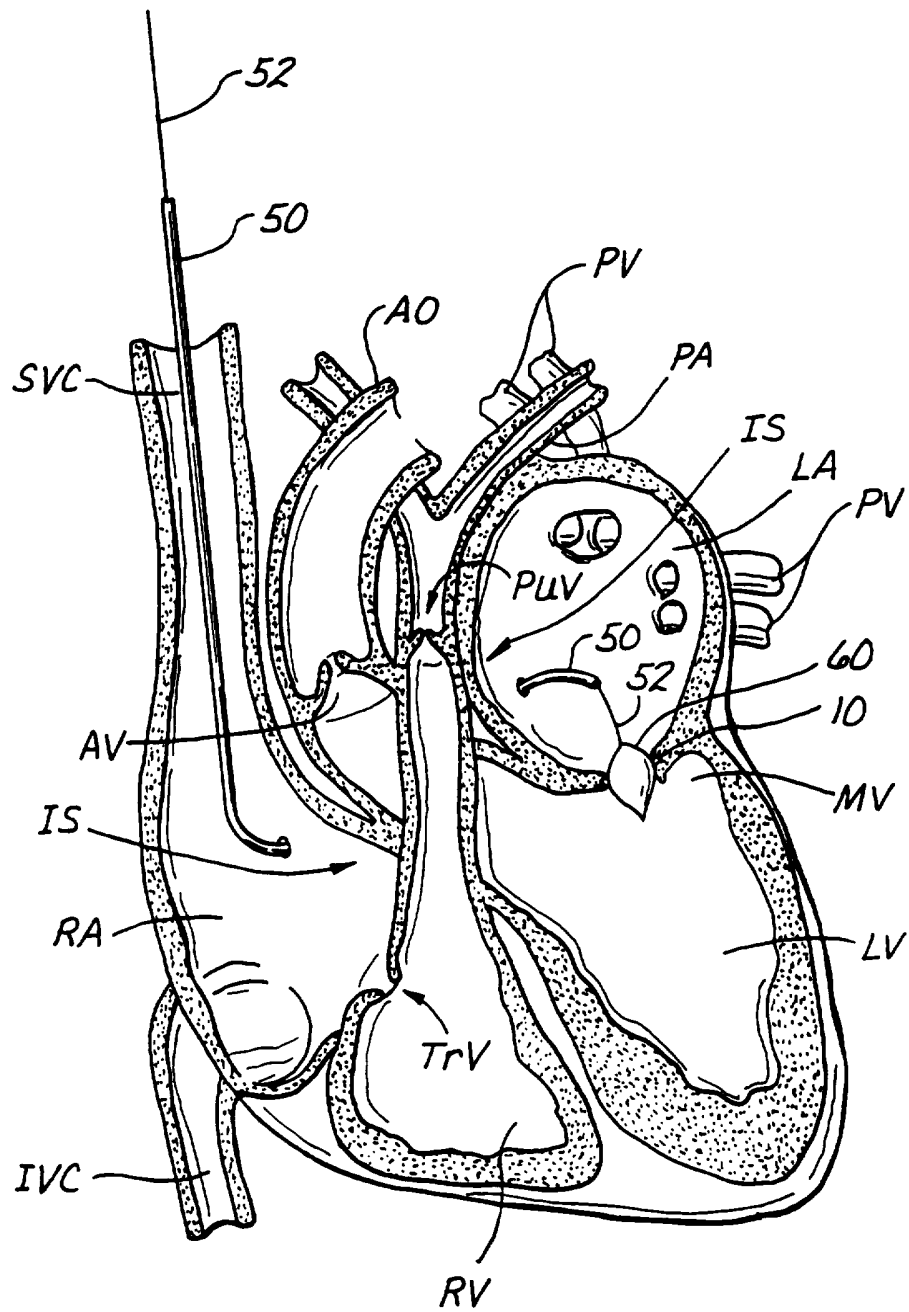

Fig. 4

INTERNATIONAL SEARCH REPORT

Intern al Application No

PCT/US 95/08419

A. CLASSIFICATION OF SUBJECT MATTER
IPC 6 A61F2/24

According to International Patent Classification (IPC) or to both national classification and IPC

B. FIELDS SEARCHED

Minimum documentation searched (classification system followed by classification symbols)
IPC 6 A61F

Documentation searched other than minimum documentation to the extent that such documents are included in the fields searched

Electronic data base consulted during the international search (name of data base and, where practical, search terms used)

C. DOCUMENTS CONSIDERED TO BE RELEVANT

Category *	Citation of document, with indication, where appropriate, of the relevant passages	Relevant to claim No.
A	US,A,4 489 446 (REED) 25 December 1984 cited in the application see abstract; figures 2,4 ---	1
A	US,A,4 602 911 (AHMADI) 29 July 1986 cited in the application see abstract; figures 1,2 ---	1
A	US,A,4 042 979 (ANGELL) 23 August 1977 cited in the application see abstract; figure 4 ---	1
A	US,A,5 061 277 (CARPENTIER) 29 October 1991 cited in the application see abstract; figures 1,3,4 ---	1
	-/--	

Further documents are listed in the continuation of box C.

Patent family members are listed in annex.

* Special categories of cited documents :

- *A* document defining the general state of the art which is not considered to be of particular relevance
- *E* earlier document but published on or after the international filing date
- *L* document which may throw doubts on priority claim(s) or which is cited to establish the publication date of another citation or other special reason (as specified)
- *O* document referring to an oral disclosure, use, exhibition or other means
- *P* document published prior to the international filing date but later than the priority date claimed

- *T* later document published after the international filing date or priority date and not in conflict with the application but cited to understand the principle or theory underlying the invention
- *X* document of particular relevance; the claimed invention cannot be considered novel or cannot be considered to involve an inventive step when the document is taken alone
- *Y* document of particular relevance; the claimed invention cannot be considered to involve an inventive step when the document is combined with one or more other such documents, such combination being obvious to a person skilled in the art.
- *&* document member of the same patent family

Date of the actual completion of the international search

8 December 1995

Date of mailing of the international search report

14. 12 95

Name and mailing address of the ISA

European Patent Office, P.B. 5818 Patentlaan 2
NL - 2280 HV Rijswijk
Tel. (+ 31-70) 340-2040, Tx. 31 651 epo nl,
Fax: (+ 31-70) 340-3016

Authorized officer

Papone, F

INTERNATIONAL SEARCH REPORT

International Application No
PCT/US 95/08419

C.(Continuation) DOCUMENTS CONSIDERED TO BE RELEVANT		
Category *	Citation of document, with indication, where appropriate, of the relevant passages	Relevant to claim No.
A	US,A,4 290 151 (MASSNA) 22 September 1981 cited in the application -----	

INTERNATIONAL SEARCH REPORT

International application No.

PCT/US 95/08419

Box I Observations where certain claims were found unsearchable (Continuation of item 1 of first sheet)

This international search report has not been established in respect of certain claims under Article 17(2)(a) for the following reasons:

1. Claims Nos.: 8-9
because they relate to subject matter not required to be searched by this Authority, namely:
PCT Rule 39.1(iv) Method of treatment of the human or anim. body by surgery
2. Claims Nos.:
because they relate to parts of the international application that do not comply with the prescribed requirements to such an extent that no meaningful international search can be carried out, specifically:
3. Claims Nos.:
because they are dependent claims and are not drafted in accordance with the second and third sentences of Rule 6.4(a).

Box II Observations where unity of invention is lacking (Continuation of item 2 of first sheet)

This International Searching Authority found multiple inventions in this international application, as follows:

1. As all required additional search fees were timely paid by the applicant, this international search report covers all searchable claims.
2. As all searchable claims could be searched without effort justifying an additional fee, this Authority did not invite payment of any additional fee.
3. As only some of the required additional search fees were timely paid by the applicant, this international search report covers only those claims for which fees were paid, specifically claims Nos.:
4. No required additional search fees were timely paid by the applicant. Consequently, this international search report is restricted to the invention first mentioned in the claims; it is covered by claims Nos.:

Remark on Protest

- The additional search fees were accompanied by the applicant's protest.
- No protest accompanied the payment of additional search fees.

INTERNATIONAL SEARCH REPORT

Intern. Application No
PCT/US 95/08419

Patent document cited in search report	Publication date	Patent family member(s)	Publication date
US-A-4489446	25-12-84	NONE	
US-A-4602911	29-07-86	DE-A- 3406469	29-08-85
US-A-4042979	23-08-77	NONE	
US-A-5061277	29-10-91	CA-A- 1303298 DE-A- 3778247 EP-A, B 0257874 JP-A- 63109856	16-06-92 21-05-92 02-03-88 14-05-88
US-A-4290151	22-09-81	AU-B- 530703 AU-B- 6089480 CA-A- 1138154 DE-A- 3028142 FR-A, B 2462150 GB-A, B 2054386 JP-C- 1348363 JP-A- 56052055 JP-B- 61013818 NL-A- 8004367	28-07-83 05-02-81 28-12-82 19-02-81 13-02-81 18-02-81 13-11-86 09-05-81 15-04-86 03-02-81