

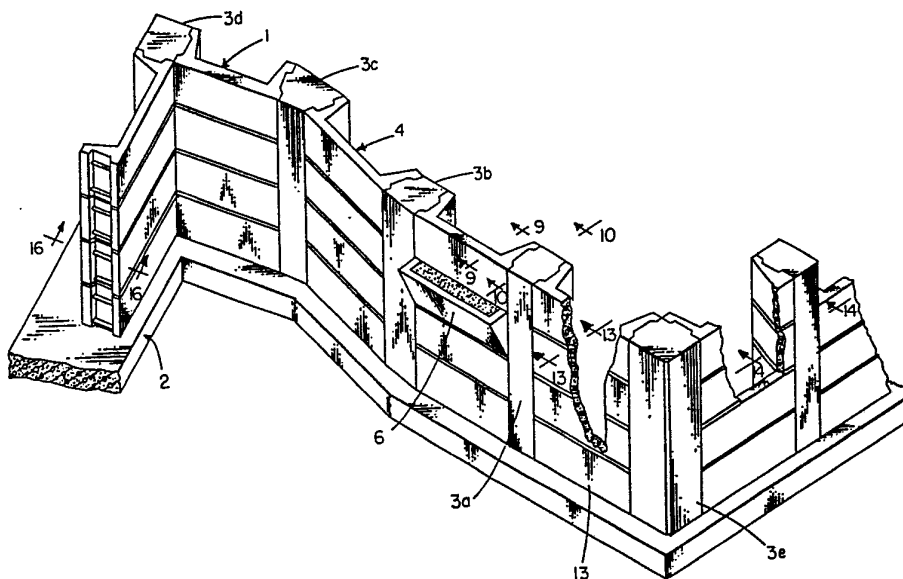

INTERNATIONAL APPLICATION PUBLISHED UNDER THE PATENT COOPERATION TREATY (PCT)

<p>(51) International Patent Classification ⁵ : E02D 5/02</p>	<p>A2</p>	<p>(11) International Publication Number: WO 90/15903 (43) International Publication Date: 27 December 1990 (27.12.90)</p>
<p>(21) International Application Number: PCT/US90/03508 (22) International Filing Date: 18 June 1990 (18.06.90) (30) Priority data: 368,028 19 June 1989 (19.06.89) US (71)(72) Applicant and Inventor: NELSON, Ned [US/US]; 3 Lake Bellevue Drive, #200, Bellevue, WA 98005 (US). (74) Agents: GARRISON, David, L. et al.; 2100 Fifth Avenue Building, Seattle, WA 98121 (US).</p>		<p>(81) Designated States: AT (European patent), AU, BE (European patent), CH (European patent), DE (European patent)*, DK (European patent), ES (European patent), FR (European patent), GB (European patent), IT (European patent), JP, LU (European patent), NL (European patent), SE (European patent).</p> <p>Published <i>Without international search report and to be republished upon receipt of that report.</i></p>

(54) Title: PRE-CAST, REINFORCED CONCRETE RETAINING WALL SYSTEM



(57) Abstract

A lightweight, pre-cast, reinforced, module (4) is used to build a structurally engineered retaining wall system (1). Each module (4) has rearwardly extending flanges (30, 40) which have an exposed horizontal reinforcing rod (26a, 26b). Upon construction, each flange (30, 40) is positioned opposite a flange (30, 40) located on an adjacent module (4). Vertical column forms (57) are attached to the distal and proximal edges of opposite flanges and the concrete columns (3a, 3b, 3c, 3d, 3e) are poured therein thereby surrounding reinforcing rods (26a, 26b). After the concrete has cured, the column forms (57) are removed.

DESIGNATIONS OF "DE"

Until further notice, any designation of "DE" in any international application whose international filing date is prior to October 3, 1990, shall have effect in the territory of the Federal Republic of Germany with the exception of the territory of the former German Democratic Republic.

FOR THE PURPOSES OF INFORMATION ONLY

Codes used to identify States party to the PCT on the front pages of pamphlets publishing international applications under the PCT.

AT	Austria	ES	Spain	MC	Monaco
AU	Australia	FI	Finland	MG	Madagascar
BB	Barbados	FR	France	ML	Mali
BE	Belgium	GA	Gabon	MR	Mauritania
BF	Burkina Fasso	GB	United Kingdom	MW	Malawi
BG	Bulgaria	GR	Greece	NL	Netherlands
BJ	Benin	HU	Hungary	NO	Norway
BR	Brazil	IT	Italy	RO	Romania
CA	Canada	JP	Japan	SD	Sudan
CF	Central African Republic	KP	Democratic People's Republic of Korea	SE	Sweden
CG	Congo	KR	Republic of Korea	SN	Senegal
CH	Switzerland	LI	Liechtenstein	SU	Soviet Union
CM	Cameroon	LK	Sri Lanka	TD	Chad
DE	Germany, Federal Republic of	LU	Luxembourg	TG	Togo
DK	Denmark			US	United States of America

0

PRE-CAST, REINFORCED CONCRETE RETAINING WALL SYSTEM

TECHNICAL FIELD

5

This invention relates to retaining walls and in particular, to pre-cast, reinforced concrete modular retaining wall systems. More particularly this invention relates to a retaining wall system that uses a pre-cast, reinforced concrete retaining wall module.

10

BACKGROUND INFORMATION

15

Many systems have been developed for protecting and physically supporting different soil elevations. A rockery, for instance, uses large size rocks which interlock and lean against an earth slope to protect the slope from slides due to weather erosion. Unfortunately, rockeries provide little or no structural support for the retained soil and are not self-supporting. They require reasonably stable native soil and are ineffective for supporting fine, sand-like soil or water.

20

In the past, different methods have been used to construct earth retaining walls. Many systems use large manufactured block-type units that interlock or key together and rely on dead weight to function.

25

McLean, (U.S. Patent No. 250,235), discloses the use of a prefabricated interlocking rectangular glass block having a full length groove and full length rib stacked one upon the other to build a glass retaining wall to hold back see water.

Schmidt, (U.S. Patent No. 2,313,363), describes a prefabricated retaining wall using blocks made from undisclosed material which are laid one on top of another in staggering superimposed rows so that each block has a longitudinal tongue on its bottom surface which overlaps the inside top edge of the lower
5 block.

Meheen, et al., (U.S. Patent No. 4,050,254), discloses a prefabricated module retaining wall using a plurality of pre-cast tie-back elements attached to curve panels. Each tie-back consists of a horizontal leg which is buried in the retained soil and exposed vertical legs. The curved panels attach to the vertical
10 legs and act to retain the soil.

Sheehan, (U.S. Patent No. 4,067,166), discloses the construction of a retaining wall using interlocking tongue and groove boxes having an elongated reinforced support bar buried in the soil.

In the related building construction art, Wolfe, (U.S. Patent No. 2,160,773), discloses the use of interlocking concrete slabs having a plane outer side and a transversely curved inner side. The slabs have reinforcing wires with looped ends which extended through rabbeted ends on each slab. These ends are abutted and the loop ends are then placed around vertical steel bars which hold the slab in place.
15

Another group of earth supporting systems seen in the prior art use
20 elements placed horizontally into the retained earth. These elements may be rigid or consist of a mat-like structure made of pencil strands which are laid horizontally and covered with compacted earth. Both the rigid members and the mats are structurally attached to a pre-cast concrete interlocking pattern of wall

units to form the system. In order to construct this type of wall system, a large horizontal area, adjacent to the wall is required. Since such areas are not always available, these systems can not be used in many situations.

5 The basic structure of a concrete retaining wall includes a footing of varying size and a relatively narrow vertical concrete wall attached to it. Structural reinforcing the rods are placed in such a manner that, in combination, the wall and the footing operate as a single unit. Using this type of retaining wall, a structural engineer can predictably and safely design a retaining wall to combat the forces found in the specific field conditions.

10 None of the prior art, however, discloses retaining wall systems using pre-cast, reinforced concrete modules combined with cast-in-place structural elements as disclosed herein.

DISCLOSURE OF INVENTION

15 It is the general object of the present invention to provide an improved pre-cast reinforced retaining wall system which will retain both soil and water.

It is an object of the invention to provide a versatile retaining wall module that can be easily adapted to different types of soils and conditions by the flexible arrangement of like modules.

20 It is an object of the invention to provide a low cost, easily fabricated, structurally engineered retaining wall system that can be built on site using modules that can be easily transported.

It is an object of the invention to provide a retaining wall module which can be made in various sizes which can be easily handled manually or with light construction machinery.

5 It is an object of the invention to provide a retaining wall system that allows for curved walls and inside or outside corners using a single, pre-cast, reinforced concrete module.

It is a further object of the invention to provide a retaining wall that can be structurally attached to a pre-constructed foundation footing.

10 It is a further object of the invention to provide a retaining wall that operates in a structurally engineered manner that requires very little excavation or alteration of surrounding soil.

It is a still further object of the invention to provide a retaining wall system with an exposed front surface which can be easily manufactured in different styles and appearances.

15 The present invention is a pre-cast, reinforced concrete module that can be used with a plurality of like modules which interconnect with vertical concrete columns to build a structurally engineered retaining wall. Disclosed herein are various embodiments of a module, a novel retaining wall structure, and methods for building a retaining wall structure.

20 In the preferred embodiment, the module is channel-shaped having a central panel with integrally attached flanges at each first and second opposite end. The central panel has parallel front and rear surfaces and parallel top and bottom surfaces. Each flange extends rearward, substantially perpendicularly to the panel's outside and inside surfaces. Each module has one or more fully

extending horizontal reinforcing rods. Each rod has one end section which commences in one flange, a central portion that extends across the panel, and a second end section that terminates in the second flange. Each rod has one end section each commencing in one flange and extending across the panel and terminating in the second flange. On the outside surface of each flange is a vertical recess across which a portion of each of the horizontal reinforcing rods is exposed. These exposed portions are later surrounded by concrete in a cast-in-place vertical reinforced column constructed between each module.

When constructing the retaining wall structure, a horizontal row of modules is placed on the top surface of a suitable reinforced footing. Each module can be lifted at each end at the exposed portions of the horizontal reinforcing rods and positioned adjacent to another module with its front surface positioned vertically. Each flange is positioned opposite to a flange located on an adjacent module with a vertical column space created in between.

Once the first row of modules are positioned, identical modules are then stacked above and aligned. Located on the top and bottom surface of each flange is an alignment means used to vertically align and, when necessary, horizontally separate stacked modules. The alignment means may comprise a pair of half-spherical or a single, V-shaped recess located on the top and bottom surface of each flange. Later, during wall assembly, complimentary spherical or elongated rectangular alignment elements are placed in the recesses to align and to vertically separate stacked modules. By using alignment elements having different cross-sectional dimensions, the space between stacked modules may be adjusted to allow for drainage of soils where necessary.

Once the modules are stacked to the desired height, reinforced vertical columns are then constructed in the column spaces located between adjacent modules by appropriate placement of concrete and steel reinforcement. Between adjacent modules, a rear column form is placed to extend between the opposite flanges and a front column form extends between the opposite front surfaces. The rear column form may be held in place by attaching a vertical edge of the form to a rear form attachment means located on either the distal or outside surface of each opposite flange. A rear form attachment means comprises either a vertical rabbet located between the distal and outer surfaces of each flange or a vertical slot located on the outside surface of each flange. The rear column form itself may be either planar for smaller columns or channel-shaped extending rearward to construct a larger column.

The front column form is usually planar and placed in front of each column space by attaching the vertical edges of each form to the front surface of each adjacent module, using a front form connecting means, such as a tie rod connector. In some instances, one tie rod connector may be positioned horizontally between stacked modules along the top surface of each flange. The ends of the connector extend beyond the distal and front surfaces of the module and serve as the attachment means for the rear and front column forms.

When the front and rear column forms are attached, concrete is then placed into each vertical column space to construct the vertical columns. The wet concrete flows into the recesses located on the outside surfaces of each opposite flange and surrounds the exposed portions of the horizontal reinforcing rods spanning the recesses. In this manner, each module is interlocked with

adjacent, superjacent and subjacent modules. Once the concrete in the column space has cured, the front and rear column forms are removed and construction of the vertical reinforced concrete column is completed. Once all of the vertical columns are constructed, all of the modules are interlocked with adjacent, superjacent, and subjacent modules creating a structurally engineered retaining wall structure. Exposed tie rod segments may be broken off as desired.

In another embodiment, a module is provided having a similar channel-shaped structure with front panel extensions projecting laterally from each opposite end of the panel, substantially perpendicular to the outside surface of each flange. The outer vertical surface of each extension has an outer edge alignment means which engages with the panel extension located on adjacent module.

As described above, during the retaining wall assembly, a horizontal row of modules is placed on a suitable reinforced footing. Each module is positioned adjacent to another module with its front surface visible and positioned vertically and with each flange positioned opposite the flange located on an adjacent module. Between each module is a vertical column space defined on two sides by the two opposite flanges and along a front surface by the two converging opposite front panel extensions.

The outer edge alignment means located on each panel extension may include a fully extending vertical slot located on the outside surface of each front panel extension. During wall assembly, complimentary modules are positioned adjacent to one another and the edges of a front flexible form made of vinyl or

some other suitable material and inserted into the opposites extending the form between adjacent modules.

Alternatively, the outer edge alignment means may include a complimentary convex or concave surface located along the vertical outer edges of each panel extension which, during wall assembly, engages with complimentary convex and concave surfaces located on adjacent modules.

In still another embodiment, the module comprises a panel having two opposite, vertical end surfaces and at least one horizontal reinforcing rod. Each rod has a central portion which transverses the panel and two exposed opposite end sections which extend rearwardly from the panel's rear surface near each opposite vertical end surface. Each panel also has a wide front and rear surface, and a narrow top and bottom surface. A rear surface attachment means, such as a bolt insert which can be attached to a bolt, is located on the rear surface of each panel. An end surface alignment means is located along each vertical end surface which aligns the front surface of each panel with the adjacent panel during wall assembly.

The end alignment means used with this embodiment may be similar to the outer edge alignment means disclosed in the second embodiment. The end alignment means many include a fully extending, centrally located vertical slot which accepts one edge of a front flexible form. When the panels are properly positioned, a front flexible form is interposed between two adjacent panels by inserting the form into the vertical slots located on the adjacent panels. The outside and inside edges of each vertical end surface may be beveled inwardly to ensure proper alignment.

Alternatively, the end surface alignment means may include a complimentary concave or convex surface located on the vertical end surfaces of each panel. When a panel is positioned adjacent to another panel, the concave vertical end engages with the convex vertical end surface located on the adjacent panel to interconnect and align the panels. The concave and convex vertical surfaces key together to properly align the adjacent panels.

Using the third embodiment to construct a retaining wall, a horizontal row of panels is first placed on a reinforced footing with panels having a complimentary end alignment means being positioned next to one another. A reusable vertical steel column form having three closed sides and an open front side is attached to and bridges the joint between adjacent panels. A vertical edge of the steel form attaches to the rear surface attachment means located on the rear surface of each adjacent panel thereby creating a closed column space therein.

During manufacture of each panel, the horizontal reinforcing rods are bent inwardly and parallel to the inside surface of each panel. When the steel column forms are attached, the rods are bent perpendicular to the rear surface and extended into the column space created by the form.

Once the first row of modules are positioned on the footing, successive rows of panels are then stacked above and attached to the steel forms until the desired wall height is achieved. Wet concrete is then placed into the column space inside each steel form surrounding the exposed portions of each horizontal rod and interlocking the adjacent, superjacent, and subjacent modules. Once the

concrete in the columns has cured, the steel forms are removed and the retaining wall structure is completed.

With each embodiment, the front surface of each module may be sloped so that slope or batter may be produced in the retaining wall structure for aesthetic or structural reasons. With this modification, the front surface of the central panel is acutely angled with respect to the bottom surface of each flange. In this manner, the front surface of each module slopes rearward into the embankment while the top and bottom surfaces of each module is horizontal and parallel with the top and bottom surfaces on the upper and lower modules.

Other features and advantages of the present invention will be brought out in the following more detailed description of a specific embodiment made in conjunction with the accompanying drawings.

BRIEF DESCRIPTION OF THE DRAWINGS

Figure 1 is a perspective view of a portion of the structurally engineered retaining wall disclosed herein.

Figure 2 is a perspective view of the first and preferred embodiment of a pre-cast, reinforced concrete module.

Figure 3 is a bottom, plan view of the preferred embodiment shown in Figure 3.

Figure 4 is a partial plan view of a portion of two adjacent modules shown in Figure 2 having opposite vertical slots located on the outside surface of each flange with a rear column form inserted therein.

Figure 5 is a partial plan view of two adjacent modules having an attached extended column form used to construct a larger rearward extending column.

5 Figure 6 is a partial plan view of another embodiment of this invention showing two adjacent modules having an attached rear column form and a pair of front panel extensions with vertical slots located on each vertical end surface with a front flexible form inserted therein.

Figure 7 is a partial, sectional, elevation view of the embodiment shown in Figure 6.

10 Figure 8 is a partial plan view of two adjacent modules having opposite front panel extensions with compatible concave and convex vertical end surfaces.

Figure 9 is a vertical cross sectional view of the retaining wall taken along lines 9-9 in Figure 1.

15 Figure 10 is a vertical cross-sectional view of the retaining wall, taken along lines 10-10 in Figure 1.

Figure 11 is a perspective view of still another embodiment of this invention comprising a panel having rearward extending horizontal rods.

20 Figure 12 is a partial plan view of two adjacent modules shown in Figure 11 wherein adjacent modules are attached to a rear steel column form with a front flexible form inserted between opposite vertical end surfaces.

Figure 13 is a partial vertical cross section, taken along lines 13-13 shown in Figure 1 showing two stacking modules aligned by a spherical alignment element located in a half-spherical recess between stacked top and bottom flange surfaces.

Figure 14(a) is a partial vertical cross section view taken along lines 14-14 shown in Figure 1 showing two stacking modules aligned by an elongated square alignment element positioned on edge in V-shaped recesses located on the top and bottom flange surfaces.

5 Figure 14(b) is a partial vertical cross section view similar to the view taken in Figure 14(a) showing the use of a smaller elongated square alignment element positioned on edge and located in a V-shaped recess creating a narrower space between stacked modules.

 Figure 15 is a partial perspective view of the alternative V-shaped
10 alignment recess located on the top surface of a module flange as shown in Figures 14(a) and 14(b).

Figure 16 is a partial vertical cross section view taken along lines 16-16 in Figure 1 showing a suitable sealant between stacked modules.

 Figure 17 is a cross-sectional view of a retaining wall with a batter using
15 modules having horizontal top and bottom flange surfaces and acutely angled panel front surfaces with respect to the bottom flange surface.

Figure 18(a) is a partial plan view of the vertical column used to make a straight wall section using the first embodiment of the pre-cast, reinforced module.

20 Figure 18(b) is a partial plan view of the vertical column used to make an inside turn on the retaining wall using the first embodiment of the pre-cast reinforced module.

Figure 18(c) is a partial plan view of the vertical column used to make an outside turn on the retaining wall using the first embodiment of the pre-cast reinforced module.

5 Figure 18(d) is a partial plan view of the vertical column used to make an inside corner in a retaining wall section using the first embodiment of the pre-cast reinforced module.

Figure 18(e) is a partial plan view of the vertical column used to make an outside corner in a retaining wall section using the first embodiment of the pre-cast reinforced module.

10

BEST MODE FOR CARRYING OUT THE INVENTION

The present invention is a structurally engineered, reinforced retaining wall system that uses a single, pre-cast, reinforced concrete module combined with cast-in-place vertical columns. The primary purpose of this system is to
15 retain soil or water where horizontal space is limited and where rockeries and other structurally poured concrete walls might be used.

Referring specifically to the drawings wherein like numerals indicate like parts there is seen a retaining wall 1, shown in Figure 1, comprised of a pre-poured, reinforced, continuous footing 2, on-site constructed vertical columns 3a,
20 3b, 3c, 3d, 3e, and horizontally positioned, stacked modules 4. Various module embodiments are disclosed in this invention. Each module is easy to fabricate and transport and easy to handle during retaining wall construction.

The first embodiment 20, shown in Figures 2 and 3, is channel-shaped, having a central panel 21 with a pair of integrally attached flanges 30 and 40 at

opposite ends. Each central panel 21 has parallel front 22 and rear 23 vertical surfaces and parallel top 24 and bottom 25 horizontal surfaces which are substantially perpendicular to the front 22 and rear 23 surfaces.

5 Right flange 30, attached at one end of central panel 21, has parallel top 34 and bottom 35 horizontal surfaces, a vertical distal surface 33 parallel to front surface 22, and an outside 31 and inside 32 surface. Located centrally on outside surface 31 is vertical recess 36.

10 Left flange 40, attached at the opposite end of panel 21, has parallel top 44 and bottom 45 surfaces, a vertical distal surface 43 parallel to front surface 22, and an outside 41 and inside 42 surface. Located centrally on outside surface 41 is vertical recess 46.

Outside surfaces 31 and 41 are parallel with each other and substantially perpendicular to front surface 22 of panel 21. As more clearly shown in Figure 3, inside surfaces 32 and 42 are obtusely angled with respect to rear surface 23.

15 As shown in Figures 2 and 3, transversing each module 20 is a pair of fully extending horizontal reinforcing rods 26 (top), 27 (bottom), each commencing in flange 30, extending across panel 21, and ending in flange 40. Portions 26(a) and 26(b) of rod 26 are exposed at recesses 36 and 46, respectively, and portions 27(a) and 27(b) of rod 27 are exposed at recesses 36 and 46, respectively. Later, portions 26(a),(b) and 27(a),(b) are surrounded by
20 concrete during the construction of the vertical column 3 located between adjacent modules 20, 20'.

As shown in Figures 2, 3, 4, and 5, right flange 30 and left flange 40 each have a rear column form attachment means which attaches to rear column form

57. In the preferred embodiment, as shown in Figures 2 and 3, the rear column form attachment means located on right flange 30 comprises a fully extending vertical rabbet 37 located between distal surface 33 and outside surface 31. On left flange 40, the rear form attachment means comprises a fully extending vertical rabbet 47 located between distal surface 43 and outside surface 41. A connector means, such as a tie rod connector 56 may be positioned along the top surfaces of each flange 30, 40 to hold the edges of form 57 within each rabbet.

As shown in Figure 4, an alternative rear column form attachment means comprises a fully extending vertical slots 38, 48 located on the outside surfaces of each flange. Slot 38 (shown on the adjacent module) is located on outside surface 31 of right flange 30 and slot 48 is located on outside surface 41 of left flange 40. During retaining wall 1 assembly, the vertical edges of form 57 are inserted into each opposite slot 38', 48 to define the rear surface of the vertical column 3.

As shown in Figure 5, the distal surface 33, 43 of each flange may be flat with a connecting means, such as tie rod connector 56 used to hold one edge of a straight 57 or extended 58 rear column form against each surface.

Located on the top 34 and bottom 35 surfaces of right flange 30 and on top 44 and bottom 45 surface of left flange 40 is an alignment means used to align and vertically separate superjacent and subjacent modules. As shown in Figures 2, 4, 13, in the preferred embodiment 20 the alignment means includes a pair of half-spherical recesses 50(a) and 50(b) located on top surface 34. Located on the bottom surface 35 of right flange 30 is a pair of half-spherical

recesses 51(a) and 51(b). On left flange 40, a pair of half spherical recesses 52(a) and 52(b) are located on top surface 44 and a pair of half-spherical recesses 53(a) and 53(b) on bottom surface 45. During the manufacture of module 20, recesses 50(a), 50(b) and 52(a), 52(b) are aligned with recesses 51(a), 51(b) and 53(a), 53(b) so that the front surfaces, 22, 22' are vertically aligned when the modules 20, 20' are stacked.

Later, during retaining wall 1 assembly, a spherical alignment element 54 is placed in each top surface alignment recess 50(a), 50(b), 52(a) and 52(b). When positioned in each recess, the upper portion of each element 54 extends above the top surfaces of each flange. As more clearly shown in Figure 13, when the modules 20, 20' are stacked, the upward extending portions of each element 54 engage with the recesses 51(a)', 51(b)', 53(a)', and 53(b)' located on the bottom flange surfaces of the stacked module 20'. By properly engaging the elements on the lower module with the recesses located on the bottom flange surfaces 35, 45 of the above module, the modules are thereby aligned.

An alternative alignment means, shown in Figures 14(a), 14(b), operates similarly to the above described means includes an elongated, V-shaped, horizontal recess 142, 144 located on top surface 34, 44, of each flange 30, 40, respectively. Complimentary recesses 143, 145 (not shown) are located on the bottom flange surfaces 35, 45 of each flange 30, 40, respectively, that are vertical aligned with the top recesses 142, 144. Each recess 142, 143, 144, 145 is positioned horizontally, oriented inwardly, and angled obtusely with respect to the rear surface 23. During retaining wall 1 assembly, a complimentary elongated square alignment element 148 is placed inside each top recess 142,

144. Like the spherical elements, the upper portion of each element 148 extends above the top surface of each flange and engages with the bottom recesses 143, 145 to align the stacked modules 20, 20'.

Both the spherical elements 54 and square elements 148 may be made
5 of wood or other suitable materials.

In the second embodiment of this invention, shown in Figures 6, 7, and 0X
8, module 60 is similar to module 20 having a channel shaped with a central
panel 61 and a pair of integrally attached flanges 70, 80 at opposite ends. Each
module 60 has a pair of fully extending horizontal reinforcing rods 66, 67
10 commencing in flange 70, extending across panel 61, and terminating in flange
80. On the outside surface 71 of the right flange 70 is a vertical recess 76 across
which portions 66(a) and 67(a) of rods 66 and 67 are exposed. On the outside
surface 81 of the left flange 80 is a vertical recess 86 across which portions 66(b)
and 67(b) of rods 66 and 67 are exposed.

15 At each opposite end of the central panel is a laterally projecting front
panel extension 90, 95. Both extensions 90, 95 are oriented in the same plane
as front surface 62 and are substantially perpendicular to outside surfaces 71 81
of the adjacent flange 70, 80.

20 Located on the outside vertical surface of each extension, is an outer
edge alignment means which aligns the front surface of the module 60 with each
adjacent module. As shown in Figures 6 and 7, the outer edge alignment means
includes a fully extending vertical slot 78, 88 located on the outside vertical
surface of each extension 90, 95. During retaining wall assembly, the extensions
90, 95 located on adjacent modules converge with slot 78 positioned opposite to

slot 88'. A front flexible form 93 is inserted in the opposite slots 78, 88' to align the adjacent modules 60, 60'. The outside vertical edges of each extension 90, 95, may be beveled to allow for further adjustment.

Alternatively, as shown in Figure 8, the outer edge alignment means may include complimentary concave 92 and convex 97 vertical surfaces located on the opposite outside end surfaces of each extension 90, 95. During retaining wall assembly, adjacent modules 60, 60' are properly aligned by engaging a concave surface 92' with the convex surface 97 located on the adjacent module 60. By using complimentary concave and convex vertical surfaces, the modules can be easily adjusted and aligned, and a front flexible form 93 is not required.

As described in the first embodiment 20, a rear form attachment means is located on or near the distal surfaces 73, 83 of each flange 70, 80. As shown in Figure 6, the rear form attachment means may include a fully extending vertical rabbet 77, 87' located on each opposite flange 70, 80'. On the first flange 70 is a vertical rabbet 77 located between the outside surface 71 and the distal surface 73. On the second flange 80 is a vertical rabbet 87 located between the outside surface 81 and the distal surface 83. As shown in the first embodiment 20 in Figure 2, a connector means, such as a tie rod connector 56, may be used to hold the edges of the rear form 57 in each rabbet.

Also as shown in Figure 4 with the first embodiment, the rear form attachment means on the second embodiment 60 (not shown) may also include a fully extending vertical slots located on the outside surfaces 71, 81 of each flange 70, 80, respectively. A connecting means, such as a tie rod connector 56, may be used to hold a rear form 57 inside each slot.

Also, as shown on the first embodiment 20 in Figure 5, the distal surfaces 73, 83 of each flange 70, 80 on module 60 may be flat and a connector means, such as tie rod connector 56, may be used to hold the rear column form directly against each distal surface.

5 Located on the top surfaces 74, 84 of the flanges 70, 80 are alignment means similar to the alignment means disclosed in the first module embodiment 20. As shown in Figures 6 and 7, a pair of half-spherical recesses 79(a) and 79(b) are located on top flange surface 74 and a pair of half-spherical recesses 163(a) and 163(b) are located on bottom flange surface 75. A pair of half-
10 spherical recesses 89(a) and 89(b) are located on top flange surface 84 and a pair of half-spherical recesses 164(a) and 164(b) are located on bottom flange surface 85. A spherical alignment element 54 is placed in each recess 79(a), 79(b), 89(a), 89(b) which engages with the recesses 163(a)', 163(b)', 164(a)', and 164(b)' located on the bottom flange surfaces 75', 85' to align the stacked
15 modules 60, 60'.

A single, elongated, V-shaped recess 147 (not shown), located on the top and bottom surfaces of each flange may be used to align the stacked modules. During retaining wall assembly, a rectangular element 148 (not shown) is placed inside each top recess. The upper portion of element 148 extends above the top
20 flange surface and engages with the recesses located on the bottom flange surface of the above stacked module 60'.

As seen in Figures 1, 2, 6 and 9 central panels 21 and 61 respectively of each module 20, 60 may be modified by extending forward to make a planter structure 6.

Except as otherwise stated, a retaining wall structure 1 can be constructed in a similar manner using either first 20 or second embodiment 60. The first steps in constructing retaining wall 1 is the excavation of soil 99 and the construction of a reinforced concrete footing 2 at the desired location. As seen in Figures 9 and 10, footing 2 may have horizontal reinforcing rods 7 which extend along the footing's 2 length. Vertical reinforcing rods 8 are placed in the footing 2 and extended upwardly therefrom at predetermined column 3 locations. Later, when the columns 3 are constructed, the upwardly extending portions of rods 8 are surrounded with concrete and interconnect footing 2 with each vertical column 3.

Once footing 2 is constructed, a horizontal row of modules is positioned along the footing's 2 upper horizontal surface 12. The modules 20 are lifted onto surface 12 either manually or with light construction machinery by lifting each module at the exposed portions 26(a), 27(a), and 26(b), 27(b) of the horizontal reinforcing bars 26, 27 located in recesses 26 and 46. Each module 20 is positioned between the extending portions of vertical reinforcing rods 8 adjacent to another module 20'. Between the opposite flanges 30, 40' is a column space 180 through which the exposed portions of rods 8 extend.

Once the first horizontal row of modules is completed, spherical alignment elements 54 made of wood or other suitable materials, are then placed into the half-spherical recesses 50(a), 50(b) located on top surface 34 of flange 30 and into the half-spherical recesses 52(a), 52(b) located on top surface 44 of flange 40. A second module 20' is then stacked and aligned above a lower module 20 by the engaging elements with half-spherical recesses 51(a)', 51(b)'

and 53(a)', 57(b)' located on the bottom flange surfaces 35' and 45' located on the stacked module. Once completed, successive rows of modules 20 are then stacked and aligned until the desired wall height is obtained.

As seen in Figure 6, when using the second embodiment 60, the front surfaces 22, 22' of adjacent modules 60, 60' are aligned by inserting a front flexible form 93 in the opposite slots 78, 88 located on adjacent front extensions 90', 95.

Once the modules are stacked to the desired height, reinforced vertical columns 3 are then constructed inside the column space 180 created between the adjacent modules. When necessary, vertical reinforcement rods 126 and horizontal rods 127 are placed in each vertical column space 180 to provide additional strength and support. As seen in Figure 5, an extended rear form 58 may be used to create a larger column space 200.

As shown in Figure 2, rear form 57 is inserted in the opposite vertical slots 37', 47 located on the opposite flanges 30', 40 of adjacent modules 20', 20. As seen in Figure 5, an extended rear column form 58 may be used in place of form 57 to construct a larger column.

As shown in Figure 5, front column form 59 is attached in front of each column space 180 or 200 with a front form attachment means. In one embodiment, the vertical edges of form 59 are attached to the front surfaces 22, 22' of each adjacent module 20, 20' using tie rod connectors 56 at each corner. Each tie rod connector 56 is positioned horizontally between the top flange surfaces 24, 34 and the bottom flange surfaces 25, 35. As seen in Figure 2, a

bore may be made in each spherical alignment element 55 through which the tie rod connector 56 may transverse.

Once all of the vertical rear column forms 57 and front column forms 59 are attached, concrete is then poured into the column space 180 to construct the reinforced column 3. When the concrete is so poured, portions of the incoming and downward flowing concrete enters recesses 36 and 46 located on the opposite flanges 30, 40 and surrounds the exposed portions 26(a), 26(b) and 27(a), 27(b) of reinforcing steel rods 26 and 27 and the added vertical 126 and horizontal 127 reinforcing rods. Once the concrete in each vertical column has cured, the rear 57 and front 59 forms are removed and construction of the vertical concrete column 3 is completed. Once all of the modules are positioned and aligned and the columns 3 are constructed, the retaining wall 1 is completed and the soil 99 surrounding wall 1 can be moved to the desired location.

As seen in Figure 17, retaining wall 1 may be modified to have a batter by manufacturing the front surface 174 of each module at an acute angle with respect to the bottom panel surface 176 and top 177 and bottom 176 flange surfaces. The distal surface 178 of each flange may be manufactured parallel with the front surface 174. With this modification, module 172 are stacked in the same manner as described above with the top 177 and bottom 176 flanges surfaces being positioned horizontal and parallel with the top and bottom flange surfaces located on the upper or lower modules. By properly aligning stacked modules 172, 172', a batter is created in the retaining wall structure.

As seen in Figures 14(a), 14(b), by interchanging smaller rectangular element 149 with larger rectangular element 148, the space 150 between stacked

modules 20, 20' may be adjusted to allow for or to prevent fluid drainage from the soil. During wall construction, the worker can adjust the space between the stacked modules by cutting two adjacent edges of the larger element 148 to reduce its cross-sectional dimension. For this reason, modules having V-shaped alignment recess may be better suited than modules having half-spherical recesses when fluid drainage may be required. Alternatively, as shown in Figure 16, cement 160 or some other suitable material may be used between stacked modules 20, 20' to prevent fluid drainage from the soil.

In Figures 11 and 12, a third embodiment of this invention is shown. Module 110 consists of a flat panel 111 having parallel front 112 and rear 113 surfaces and parallel top 114 and bottom 115 surfaces. A pair of fully extending horizontal reinforcing rods 116, 117 traverses panel 111 and extends rearward from rear surface 113 exposing portions 116(a) and 116(b) of rod 116 and portions 117(a) and 117(b) of rod 117. A pair of expansion bolt inserts 120(a) and 120(b) are located centrally on the rear surface 113.

On each vertical end surface of panel 111 are end surface alignment means which are used to align adjacent modules. In one embodiment, the end alignment means includes vertical slots 130, 135 located at opposite end surfaces in which a front flexible form 89 may be inserted. During the manufacturing of panel 111, portions 116(a) and 116(b) of rod 116 and portions 117(a) and 117(b) at rod 117 are bent inward parallel to the rear surface 113. Alternatively, complimentary concave and convex vertical surfaces may be manufactured along each vertical end surface to align adjacent modules similar to the complimentary

concave 92 and convex 97 vertical surfaces described in the second embodiment seen in Figure 8.

The first step in constructing a retaining wall with module 110, is the construction of a reinforced concrete footing 2 having vertical extending reinforcement rods at predetermined column locations. Once the footing is completed, a horizontal row of modules 110 is positioned on top surface 112 between the column locations. A reusable, vertical steel form 125 is attached between adjacent modules 110 and 110' at each column location with bolts 121(a) and 121(b) which connect to bolt inserts 120(a) and 120(b) located on the rear surface of each adjacent module 110. As seen in Figure 12, exposed portions 116(a)' and 116(b) of rod 116 and portions 117(a)' and 117(b) of rod 117 attached to the adjacent module are bent reasonably perpendicular to the rear surface 113 and extended into column space 140. A front flexible form 93 is then inserted in opposite slots 130' and 135 located on adjacent modules 110', 110.

After each row of modules is properly positioned and aligned, successive rows of modules are aligned above and attached to steel form 125. Once all of modules 110 are aligned and attached to steel form 125, vertical 126 and horizontal 127 rods are added to each column space 140 when necessary. Concrete is then poured into the column space 140 surrounding rods 116 and 117 and the vertical 126 and horizontal 127 rods to construct the column. After columns have cured, steel forms 125 are removed and can be used again.

As shown in Figure 18(a)-(e), the path of the retaining wall 1 can be changed and different vertical columns can be constructed by changing the

relative positions of the adjacent modules. In this manner, the dimensions of the columns rear and front column surface dimensions can be varied to create either straight 18(a), inside 18(b), or outside 18(c) wall sections and inside 18(d) or outside 18(e) turns.

5 The precasting of the herein disclosed modules, depending on various factors, such as their size, the location and size of the job site, the location of concrete mixing plants, the availability of concrete delivery trucks, the availability of access roads, the availability of concrete pumping equipment, and/or the availability of good weather will determine whether the modules will
10 be made at the job site, at the concrete factory site, and/or another selected site.

Each module can be manufactured in various sizes. The selected size will depend on many factors. They may be sized to be handled by two men. However, they preferably will be sized to be handled by comparatively small-sized construction machinery.

15 In compliance with the statute, the invention has been described in language more or less specific as to its features. It is to be understood, however, that the language is not limited to the specific features shown, since the means and composition disclosed comprises preferred forms of putting the invention into effect. The invention is, therefore, claimed in any of its forms or
20 modifications within the legitimate and valid scope of the appended claims, appropriately interpreted in accordance with the doctrine of equivalence.

INDUSTRIAL APPLICABILITY

Pre-cast, reinforced retaining wall modules will find wide spread use in every industry where there exists a need for a retaining wall structure to retain soil or water. The modules and retaining wall system described herein will be especially useful in the building and road construction and landscaping industries.

CLAIMS**I CLAIM:**

1. A retaining wall module, comprising:
 - (a) a vertically disposed panel;
 - (b) a pair of vertically disposed flanges, said flanges horizontally disposed at opposite ends of said panel and projecting rearwardly therefrom, said flanges each having a vertically disposed outside recess, said recess being horizontally transversed by at least one exposed rod embedded in said flanges on each side of said recess.
2. A retaining wall module as recited in Claim 1, further comprising a vertical recess located on the rearward end of each said flange.
3. A retaining wall module as recited in Claim 2, wherein said vertical recess comprises a vertical slot located on an outside surface of each said flange.
4. A retaining wall module as recited in Claim 1, wherein said module is made of concrete.
5. A retaining wall module as recited in Claim 1, further comprising:
 - (a) at least one pair of complimentary and aligned first and second elongated V-shaped slots, said first V-shaped slot located on a top surface of a

flange of a lower of two stacked modules, and said second V-shaped slot located on a bottom surface of a flange of an upper of two stacked modules; and,

(b) an elongated square cross-sectional body of such cross sectional size that when positioned in said first slot, an upper portion of said square body extends above said top surface to engage said second slot when said modules are stacked, thereby aligning said modules.

6. A retaining wall module as recited in Claim 5, wherein said elongated square body is made of wood.

7. A retaining wall module as recited in Claim 1, further comprising, on opposite outer vertical edges of said panel, a panel edge alignment means.

8. A retaining wall module as recited in Claim 7, wherein said panel edge alignment means comprises a vertical slot located on each said outer panel edge.

9. A retaining wall module as recited in Claim 7, wherein said panel edge alignment means comprises a vertical concave edge and a vertical convex edge.

10. A retaining wall system, comprising:

(a) a footing having a spaced apart plurality of groups of vertical column reinforcing rods, each group having at least one rod, said rods projecting upwardly from said footing; each said module having a pair or rearwardly

projecting flanges, each said flange having a vertical outside surface with a vertical recess, said recess transversed by at least one exposed rod embedded in each side of said recess, whereby opposing outside surfaces of said flanges on adjacent stacks define two vertical column surfaces; and,

(b) a plurality of stacks of precast modules vertically stacked between successively spaced groups of said rods--;

(c) at least one cast-in-place vertical column between successive stacks of modules, each said column interlocking with said transverse rods in said recesses and with said vertical column rods.

11. A method for building a retaining wall system comprising the steps of:

(a) building a continuous, reinforced footing, said footing have vertically extending spaced apart groups of reinforcing rods;

(b) vertically stacking, between successively spaced groups of said reinforcing rods, precast modules, each module having exposed horizontally transverse rods on opposite ends of each said module wherein said transverse rods are embedded in side faces of a vertical recess and are exposed by transversing said vertical recess on an outer surface of a rearwardly projecting flange located on each opposite end of said module, opposing ends of said modules defining two faces of a vertical column space surrounding said reinforcing rods;

(c) closing the remaining open faces of said column area with vertical forms;

(d) pouring concrete into said column space thereby interlocking said exposed transverse rods of said modules and said vertically extending reinforcing rods of said footing.

12. The apparatus of Claim 5 wherein said elongated square body is of sufficient cross sectional size that when said modules are stacked, they are separated vertically from each other by said square body.

13. The retaining wall system of Claim 10 wherein the number of vertical column reinforcing rods in each group is a plurality.

14. The retaining wall system of Claim 10 wherein each of said groups of said vertical column reinforcing rod are so disposed to project upwardly from said footing, and each of said plurality of stacks of precast modules are so disposed upon said footing, that said groups of vertical column reinforcing rods are positioned in each said vertical column relatively rearwardly in said column.

15. The retaining wall system of Claim 14 wherein each of said precast modules further comprises a vertical recess on the rearward end of each said flange, and a panel edge alignment means on opposite outer vertical edges of each said panel, whereby vertical form members may be aligned with said stacks of modules to define, in combination with said opposing outside surfaces of said flanges on adjacent stacks, all of the vertical column surfaces of said cast-in-place vertical column.

16. The retaining wall system of Claim 15 wherein said footing does not follow a straight line, and said adjacent stacks of precast modules are disposed in relation to one another to form more than one kind of vertical column cross sectional shape, whereby a nonlinearly disposed wall is formed.

17. The method of Claim 11 wherein said precast modules are vertically stacked between said successively spaced groups of reinforcing rods such that each vertical stack of precast modules is positioned on said footing so that said vertically extending reinforcing rods occupy a position relatively rearwardly in said column space.

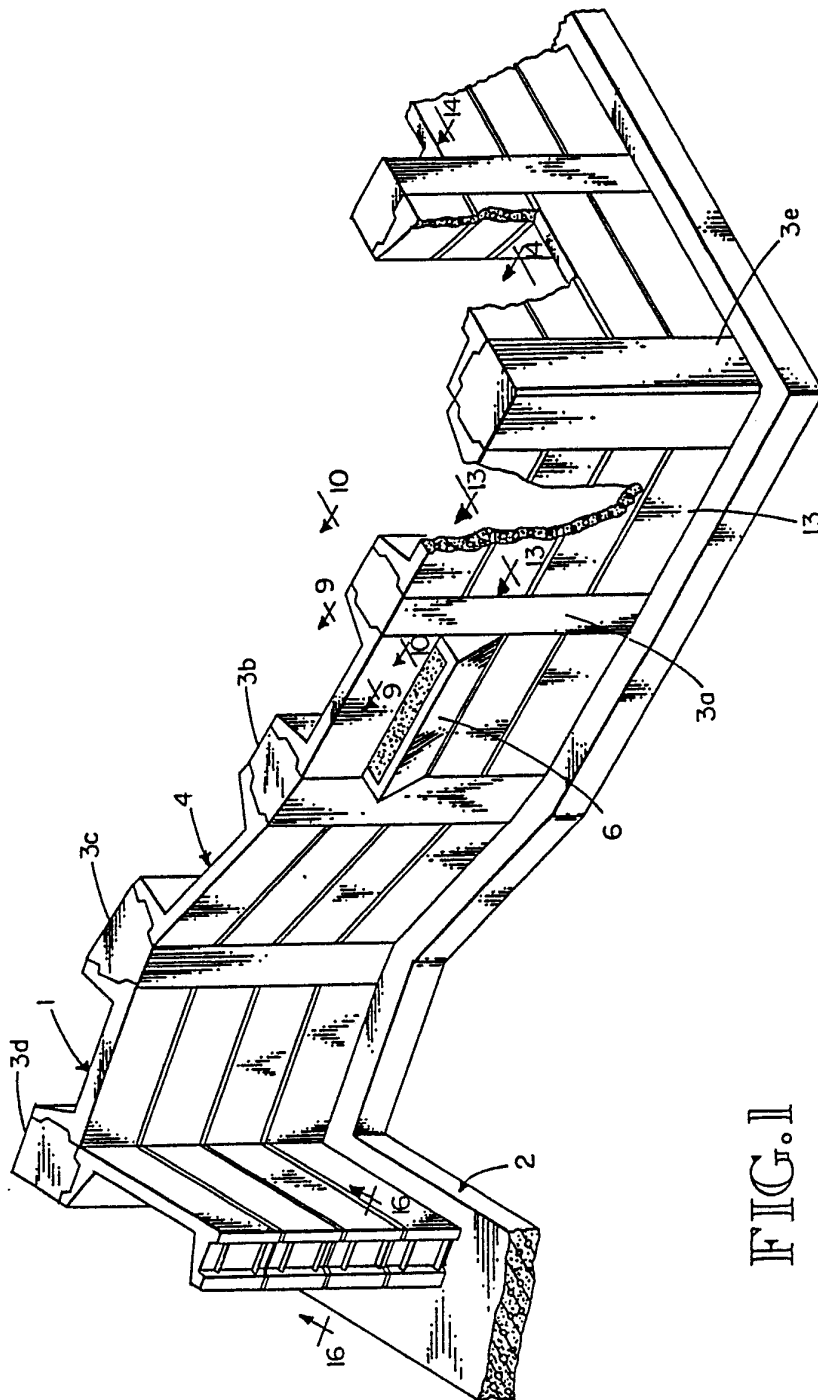

FIG. 1

FIG.2

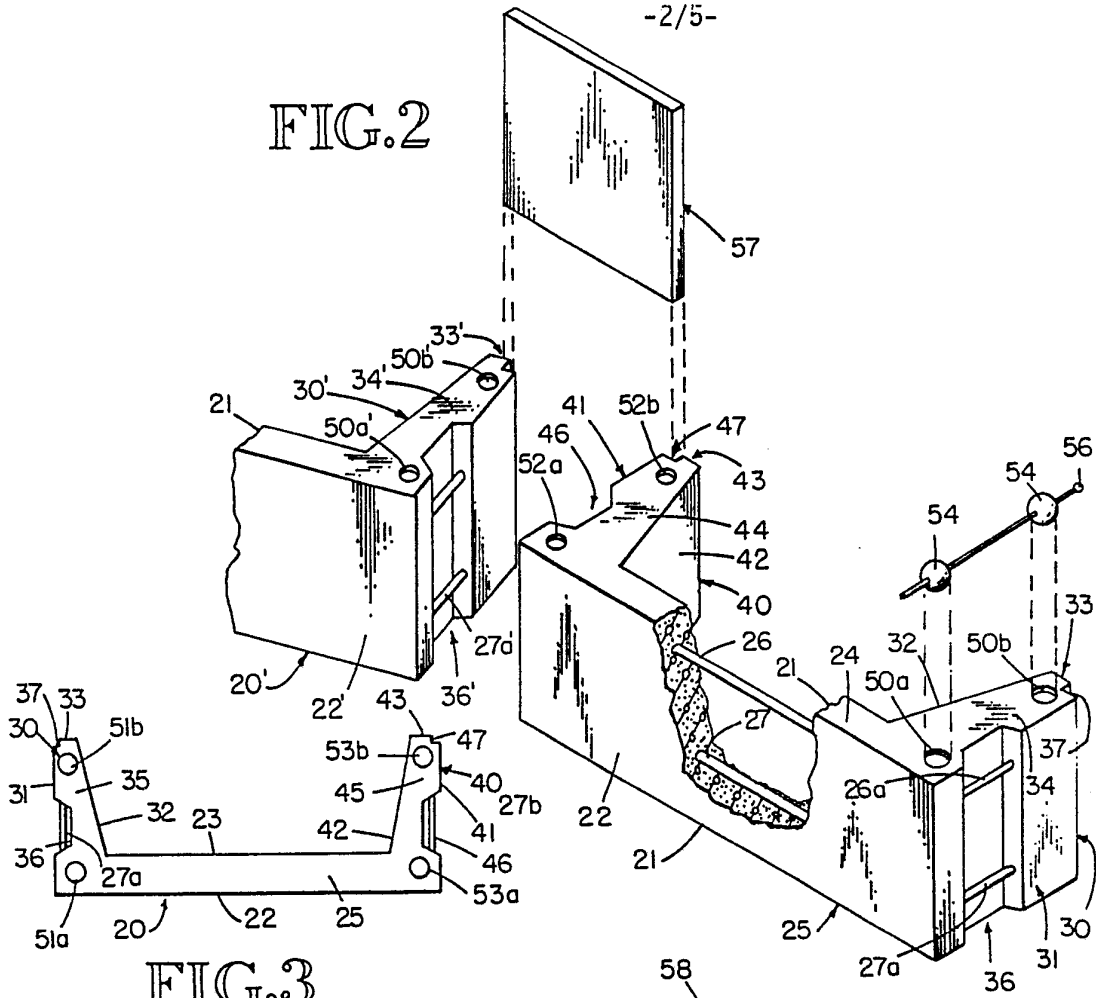

FIG.3

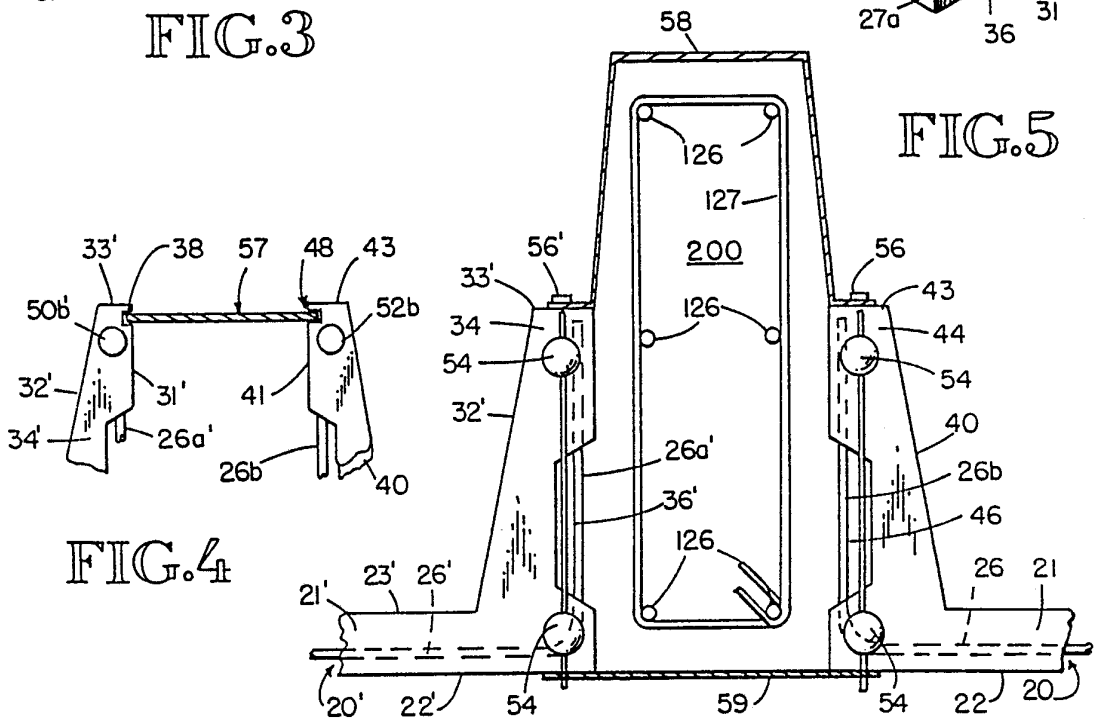

FIG.5

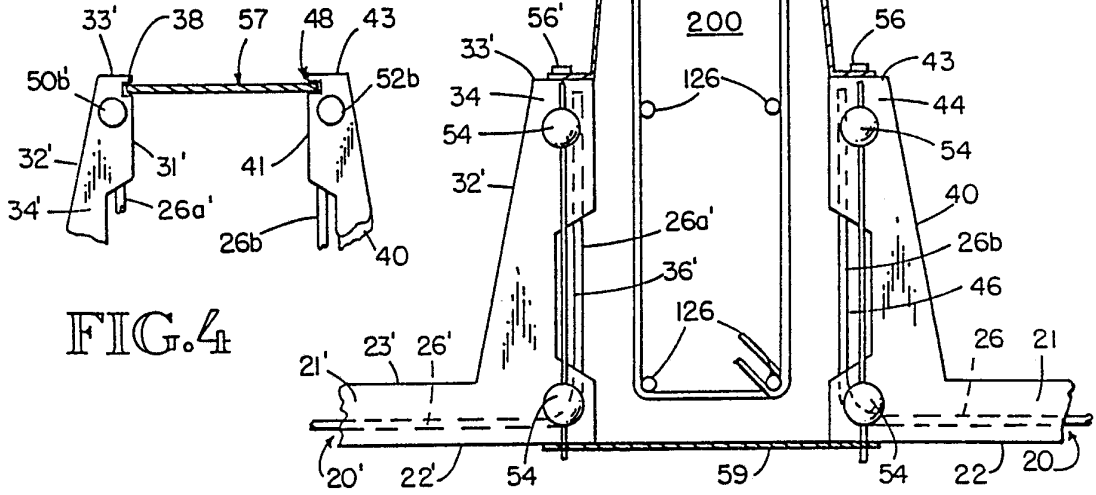

FIG.4

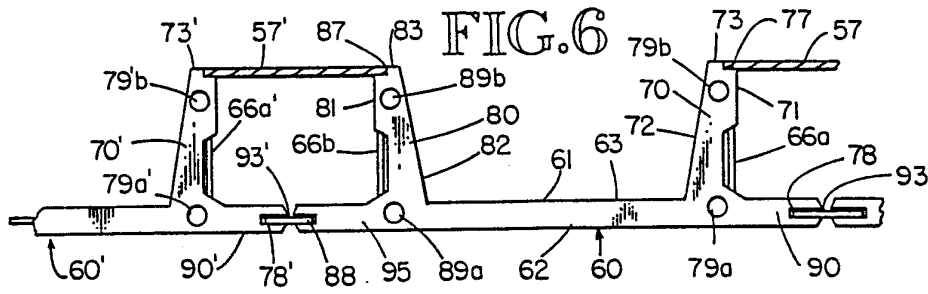

FIG. 6

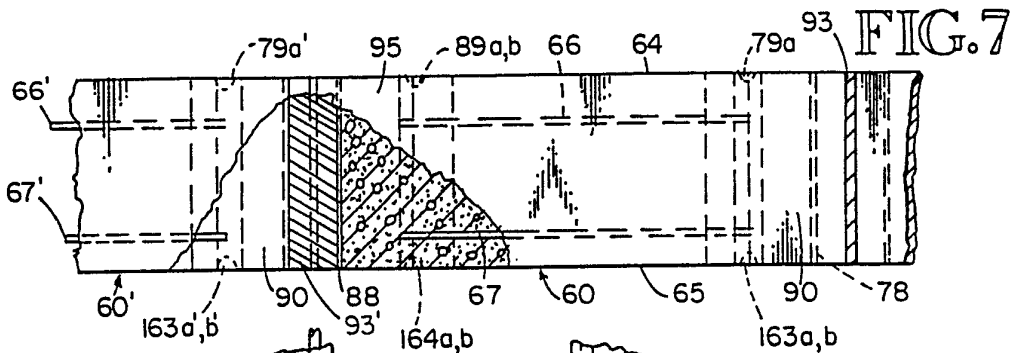

FIG. 7

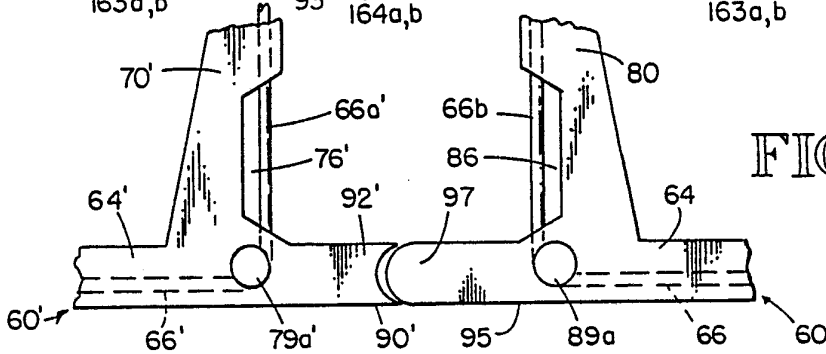

FIG. 8

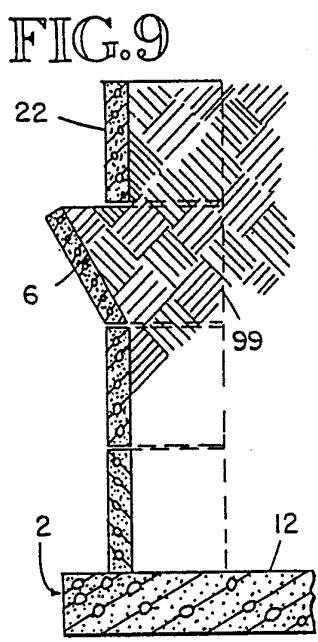

FIG. 9

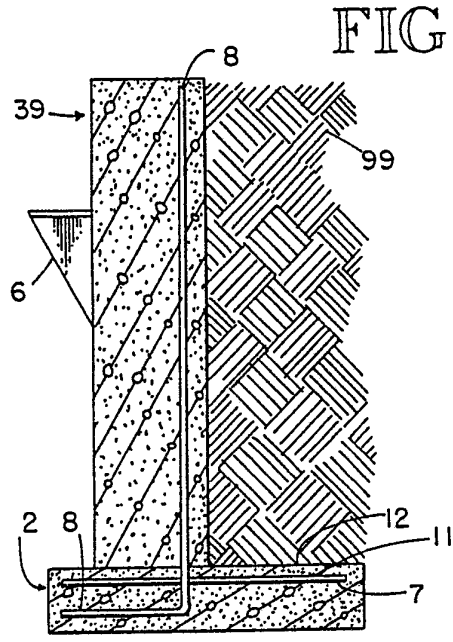
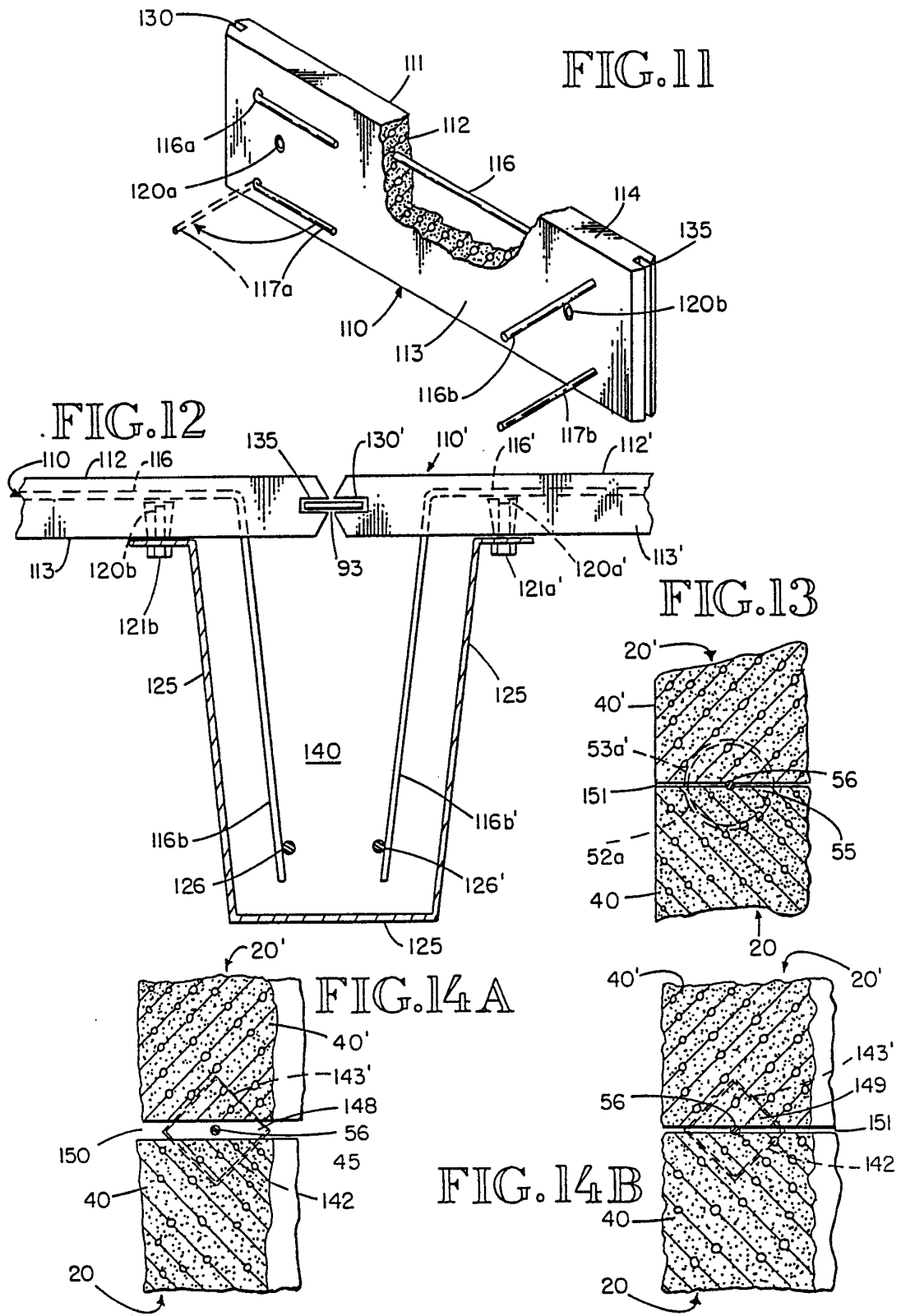

FIG. 10



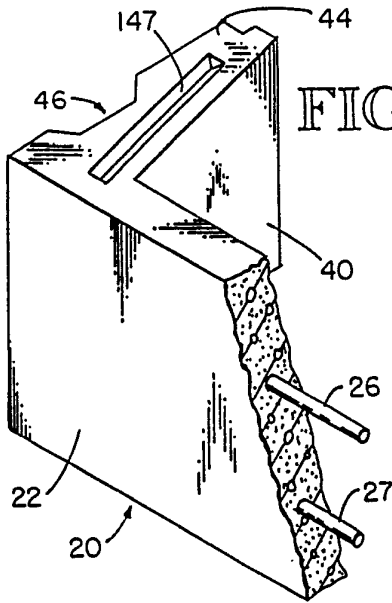

FIG. 15

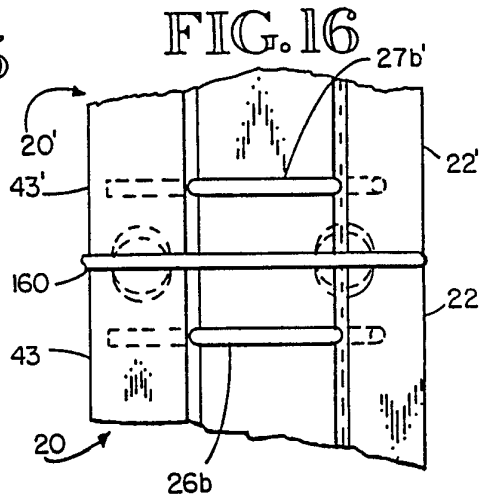

FIG. 16

FIG. 17

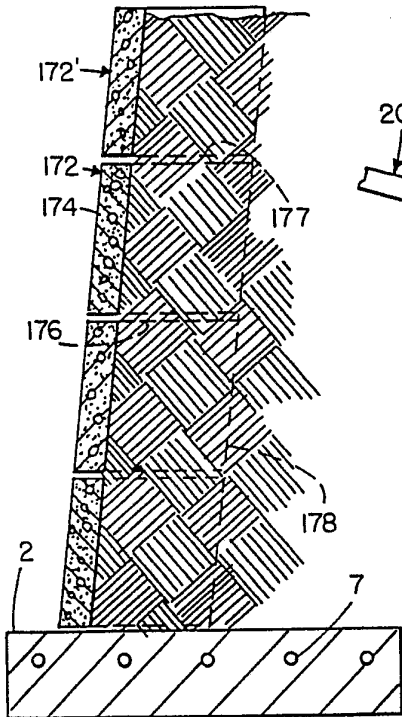

FIG. 18A

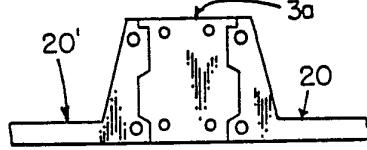

FIG. 18B

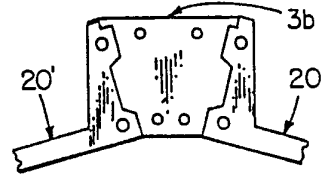

FIG. 18C

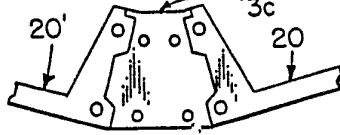

FIG. 18D

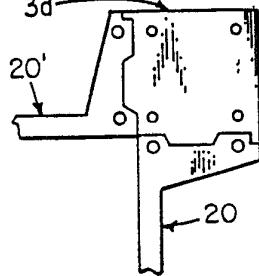

FIG. 18E

