

June 29, 1926.

1,590,536

T. H. MARS

GEARING

Filed June 25, 1924

2 Sheets-Sheet 1

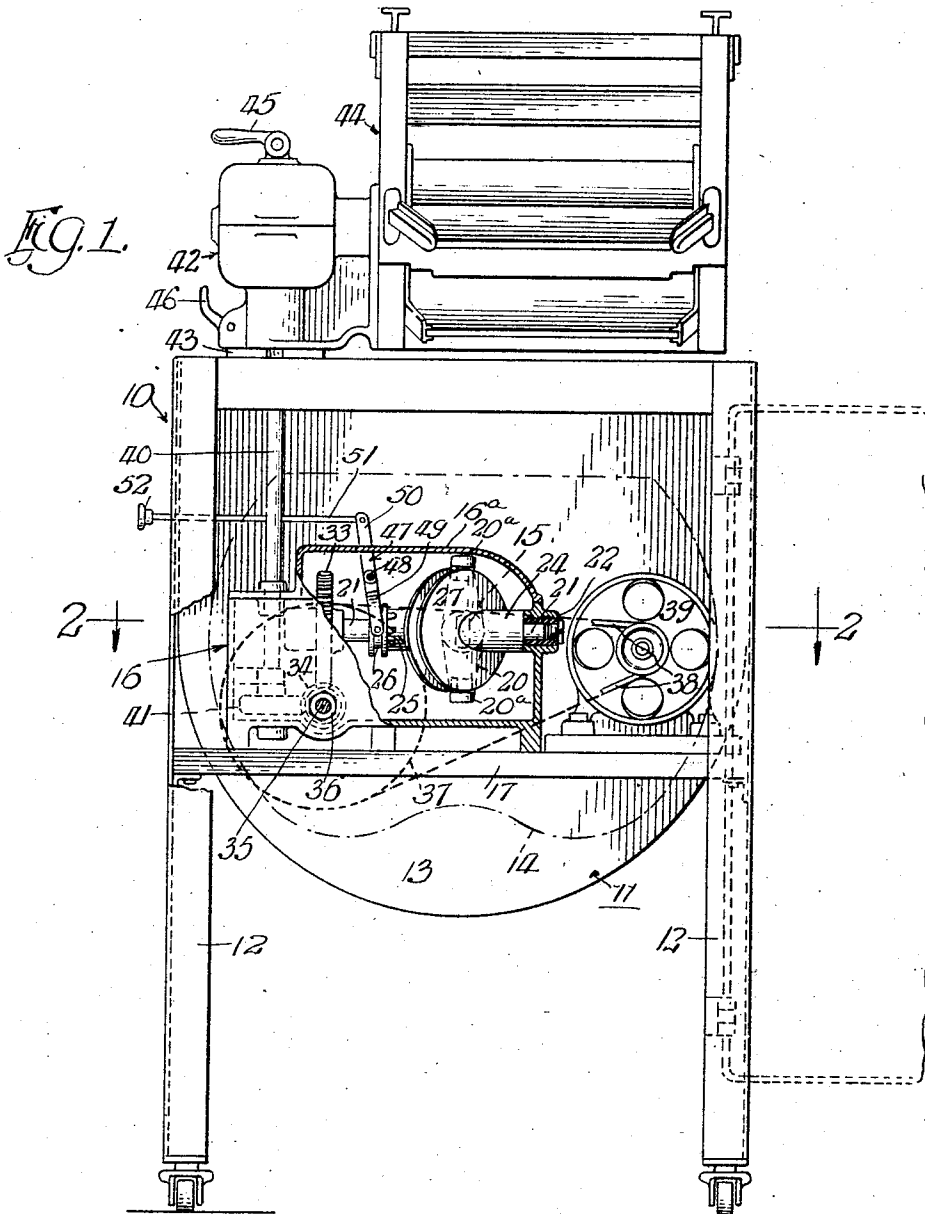

Inventor  
Thomas H. Mars  
by Clarence E. Melchrope  
Atty.

June 29, 1926.

1,590,536

T. H. MARS

GEARING

Filed June 25, 1924

2 Sheets-Sheet 2

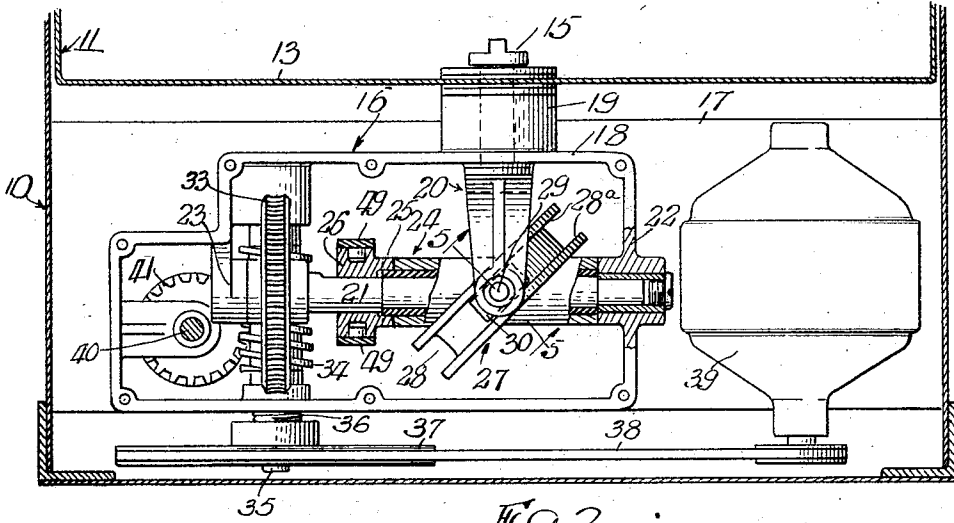

FIG. 2.

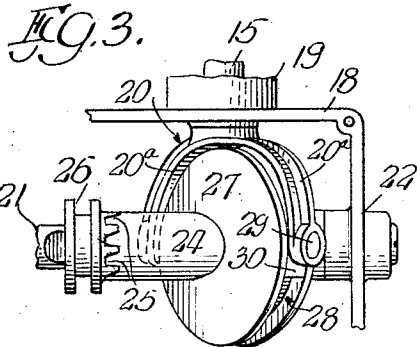

FIG. 3.

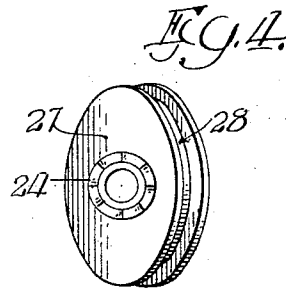

FIG. 4.

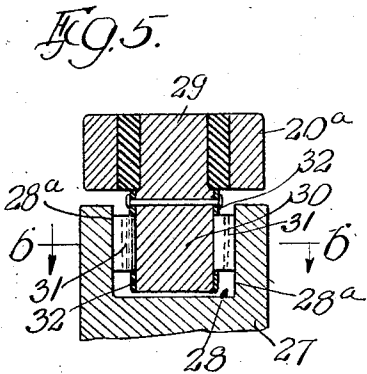

FIG. 5.

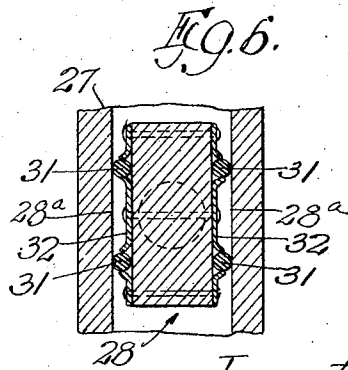

FIG. 6.

Inventor  
Thomas H. Mars  
by Clarence E. Mellock  
Att'y.

## UNITED STATES PATENT OFFICE.

THOMAS H. MARS, OF CHICAGO, ILLINOIS, ASSIGNOR TO FEDERAL ELECTRIC COMPANY, OF CHICAGO, ILLINOIS, A CORPORATION OF ILLINOIS.

## GEARING.

Application filed June 25, 1924. Serial No. 722,198.

This invention relates to improvements in gearing for washing machines and the like, and consists of the matters hereinafter described and more particularly pointed out in the appended claims.

The object of the invention is to produce a simple and efficient gearing, and one comprising few parts, all capable of being enclosed in an oil bath, for operating the alternating rotary member of a washing machine, and the wringer mechanism usually carried by such a washing machine.

This, and several other objects and advantages of the invention, will appear more fully as I proceed with my specification.

In the drawings:—

Fig. 1 is a front view of a washing machine of familiar type, provided with the usual water containing tub with an oscillating rotary clothes container therein, said washing machine being driven by the improved gearing which is shown partly in front elevation and partly in section.

Fig. 2 is a view representing a horizontal section through Fig. 1 in a plane indicated by line 2—2 in Fig. 1.

Fig. 3 is a view showing part of the mechanism in a different position than that shown in Fig. 2, as will be more particularly pointed out later.

Fig. 4 is a detailed perspective view of an actuating cam comprising one of the elements of the improved gearing.

Fig. 5 is a detailed sectional view of a part of the gearing; the plane of the section being indicated by the line 5—5 of Fig. 2.

Fig. 6 is a transverse section of the parts shown in Fig. 5,—the plane of which is indicated by the line 6—6 in Fig. 5.

Referring now in detail to that embodiment of the invention illustrated in the drawings:—10 indicates the main support for the gearing, which as illustrated herein, is the frame of a washing machine of the cylinder type. The frame includes a rectangular tub 11, which is mounted at its corners upon front and rear pairs of upright legs, only the legs 12 of the front pair being shown in this instance. Said front pair of legs are connected at their top and bottom so as to brace the frame as a whole. The tub 11 has a rounded bottom wall which merges into the upright side walls and includes upright front and rear end walls. The front end wall 13 is spaced inwardly from the

plane of the front legs 12 to provide a compartment or space between said front walls and legs, in which the improved gearing is located,

14 indicates the clothes receiving cylinder which is mounted in the end walls of the tub in any convenient manner so as to be capable of an oscillatory movement of the required amplitude. Said cylinder is detachably connected to a horizontally disposed, longitudinally extending operating shaft 15.

16 indicates a gear case or box which is mounted in the compartment or space provided in front of the wall 13 and is supported on a bar or platform 17, which extends transversely across said space and is suitably attached at its ends to the legs 12—12 of the frame. Said gear case has an upright rear wall 18 on the rear face of which is provided a bearing sleeve 19 through which the shaft 15 extends. At the forward end of said shaft and within the box 16, the shaft 15 has fixed to it, preferably as an integral part of its construction, a fork 20, having laterally spaced arms 20<sup>a</sup>.

21 indicates a horizontal shaft extending substantially the length of the gear case 16 and having bearing at one end in the end wall 22 of said box. Said shaft is located in the space between the ends of the fork arms 20<sup>a</sup>—20<sup>a</sup> and the other end of said shaft has bearing in a bracket 23, fixed to one wall of the gear case.

24 indicates a sleeve loosely mounted on the shaft 23 and provided at its left-hand end as shown, with clutch teeth 25 adapted to be engaged with like teeth on a clutch collar 26, which is now rotatively but slidably secured to the shaft 21 adjacent the end of the sleeve 24. By means of this clutch 26, the sleeve 24 may be fixedly connected with the shaft 21, so as to rotate therewith.

27 indicates a cam which is in the form of a flat spool with a rectangular groove 28 in its periphery. Said cam is fixed on the sleeve 24 in a plane extending at an angle to the central axis of the sleeve 24. The fork arms 20<sup>a</sup> embrace the cam spool 27 and are provided at their ends with rotative pins 29 having shoes 30 which engage in the rectangular groove 28 of the cam. Said shoes being preferably provided at their sides with spaced anti-friction rollers 31 for engagement with the sides 28<sup>a</sup> of the cam groove,

said anti-friction rollers being held in place by retainer plates 32—32 on opposite sides of each shoe 30.

The construction is such that when the shaft 21 is rotated and the sleeve 24 is connected thereto by the clutch collar 26, said sleeve and its cam 27 will likewise be rotated and cause the fork 20 to impart an oscillatory rotary movement to the shaft 15.

Secured to the shaft 21 adjacent to the bearing 23 is a worm gear 33. Said gear meshes with a worm 34 on a horizontal shaft 35 which is arranged in a plane below and extends at a right angle to the shaft 21. The shaft 35 is journaled in suitable bearing sleeves on the front and rear walls of the gear case 16 and said shaft projects through a stuffing box 36 on said front wall and has fixed to it a pulley 37. Said pulley is driven by a belt 38 from an electric motor 39 which is mounted on that end of the platform 17 near the right-hand leg 12.

40 indicates an upright shaft which is journaled at its bottom end in suitable bearing sleeves formed on the casing 16 and its cover plate 16<sup>a</sup> respectively. Fixed to said upright shaft 40, within the casing 16 is a worm gear 41 which meshes with the worm 34 before mentioned. The top end of said shaft projects above the top of the washing machine frame and is journaled in a gear box 42. Said gear box which is capable of a swinging movement about a hollow standard 43, through which the shaft 40 extends, contains the reverse gearing for the rolls of a clothes wringer 44 which is rigidly secured to one side of the gear box 42. A lever 45 is provided at the top of the gear box for actuating the reverse gears within said box while a second lever 46 is so connected to the bottom end of the gear box as to lock the wringer to the standard 43 in any one of the desired angular positions into which it may be swung.

The clutch member 26 on the shaft 21, is actuated by a lever 47 which is pivoted between its ends on a cross pin 48 carried by the cover 16<sup>a</sup> of the casing 16. The bottom end of said lever is forked as at 49 to straddle and engage the peripherally grooved end of said clutch member, while the top end 50 of said lever extends up through a suitable slot in the cover 16<sup>a</sup>. To said top end of the lever is connected a horizontal rod 51 and said rod carries a knob at that end which projects beyond the left-hand side of the machine frame as shown in Fig. 1.

Assume that the motor 39 is running and is driving the shaft 35 through the belt 38 and pulley 37. The shafts 21 and 40, being connected by the worm gears 33 and 41 respectively to the worm 34 on the shaft 35, will also be continuously driven in one direction. When the clutch 26 is engaged with the sleeve 24, said sleeve is locked to the

shaft 21 and will rotate therewith. In the rotation of the sleeve 24 and cam 27 thereon, the fork 20 and the operating shaft 15 to which it is fixed, is caused to oscillate through a predetermined amplitude which as shown herein is 90°,—that is 45° on one side of center and 45° on the other side of center. By reason of the construction just mentioned, the oscillation of the clothes cylinder or container slows down towards the ends of the oscillations and is hastened or is faster at the point midway between said ends so that no undue shock or jar is imparted to the rest of the associated gearing and the torque on the driving motor is therefore greatly reduced.

As before stated the upright shaft 40 is driven continuously in one direction when the motor 39 is running. Thus through the movement of the lever 45, the action of the wringer rolls is readily controlled and said rolls may be driven in either direction, when the clothes cylinder is oscillating or is idle as when the clutch 26 has been shifted out of engagement with the cam sleeve 24.

By enclosing the clutch member in the casing 16, which contains a lubricant, it cannot become rusty, due to splashing water and therefore it will not stick and bind as heretofore.

The entire gearing including the cam and fork on the operating shaft is enclosed in the casing 16 so that it is impossible for the clothing of the operator to become caught therein. Furthermore the noise of operation is materially reduced.

While in describing my invention, I have referred to certain details of mechanical construction and arrangement of parts thereof, I do not wish to be limited thereto except as may be pointed out in the appended claims.

I claim as my invention:—

1. In combination, a gear box having upright front, rear and end walls, a rotary, oscillatory driven shaft bearing in and extending beyond said rear wall, a driving shaft within said gear box with its axis of rotation extending at right angles to and intersecting the axis of rotation of said driven shaft, a sleeve loosely mounted on said driving shaft in the neighborhood of said driven shaft, a cam fixed to said sleeve and having a cam groove in a plane located in the angle between the axes of rotation of said two shafts and containing the point of intersection thereof, a fork fixed to the inner end of said driven member within said gear box and having arms operatively engaged with said cam groove at diametrically opposite points, an operating shaft bearing in the front and rear walls of said gear box, a worm and gear connection between said operating shaft and said driving shaft, a clutch member on said driving

shaft adapted to connect said sleeve to said driving shaft, and an arm extending out of said gear box for operating said clutch member.

5 2. In combination, a gear box having upright front, rear and end walls, a rotary oscillatory driven shaft bearing in and extending beyond said rear wall, a driving shaft within said gear box with its axis of rotation extending at right angles to and intersecting the axis of rotation of said driven shaft, a sleeve loosely mounted on said driving shaft in the neighborhood of said driven shaft, a cam fixed to said sleeve and having a cam groove in a plane located in the angle between the axes of rotation of said shafts and containing the point of intersection thereof, and a fork fixed to the inner end of said driven member within said gear box and having arms operatively engaged with said cam groove at diametrically opposite points.

3. In combination, a gear box having upright front, rear and end walls, a rotary, oscillatory driven shaft bearing in and extending beyond said rear wall, a driving shaft within said gear box with its axis of rotation extending at right angles to and intersecting the axis of rotation of said driven shaft, a sleeve loosely mounted on said driving shaft in the neighborhood of said driven shaft, a cam fixed to said sleeve and having a cam groove in a plane located in the angle between the axes of rotation of said shafts and containing the point of intersection thereof, a fork fixed to the inner

end of said driven member within said gear box and having arms operatively engaged with the cam groove at diametrically opposite points, an operating shaft bearing in the front and rear walls of the gear box, and a worm and gear connection between said operating shaft and said driving shaft.

4. In combination, a gear box having upright front, rear and end walls, a rotary oscillatory driven shaft bearing in and extending beyond said rear wall, a driving shaft within said gear box with its axis of rotation extending at right angles to and intersecting the axis of rotation of said driven shaft, a sleeve loosely mounted on said driving shaft in the neighborhood of said driven shaft, a cam fixed to said sleeve and having a cam groove in a plane located in the angle between the axes of rotation of said shafts and containing the point of intersection thereof, a fork fixed to the inner end of said driven member within said gear box and having arms operatively engaged with the cam groove at diametrically opposite points, an operating shaft bearing in the front and rear walls of the gear box, a continuously rotating upright driven shaft journaled in said gear box, and worm and worm gear connection between said continuously rotating driven shaft and said driving and operating shafts.

In testimony that I claim the foregoing as my invention, I affix my signature this 16 day of June, A. D. 1924.

THOMAS H. MARS.