

No. 719,969.

PATENTED FEB. 3, 1903.

G. W. WOOD.  
ROTARY ENGINE.  
APPLICATION FILED NOV. 18, 1901.

NO MODEL.

3 SHEETS—SHEET 1.

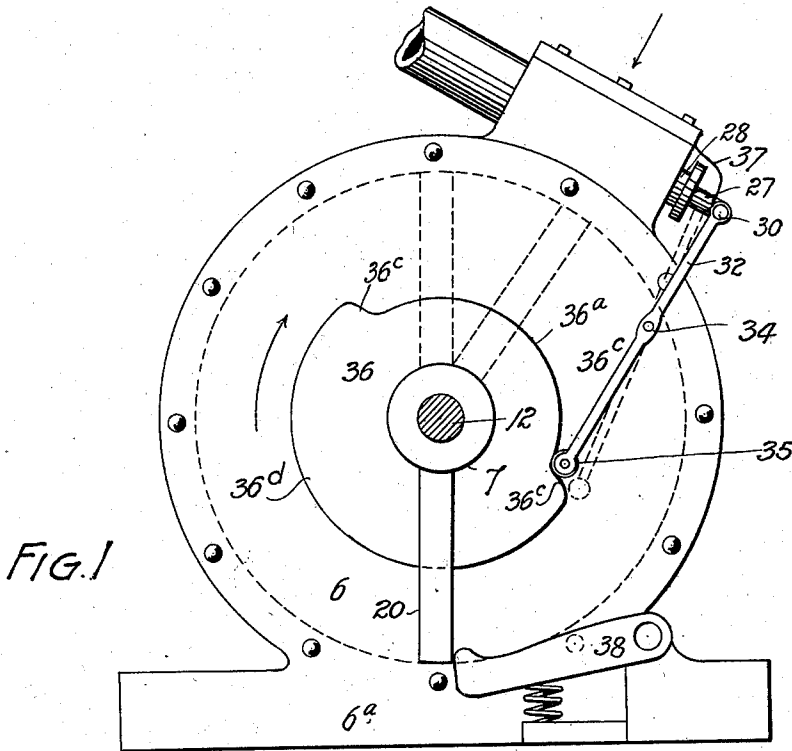

FIG. 1

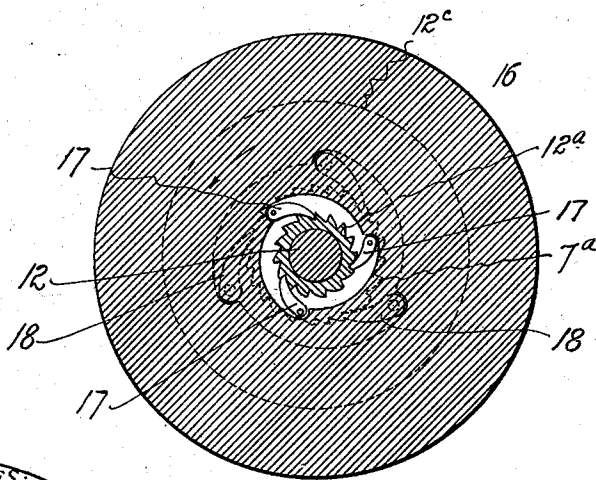

FIG. 2

WITNESSES:

*G. J. Delaune*  
*Dena Nelson*

INVENTOR.

*Geo. W. Wood.*

BY

*A. J. [Signature]*  
ATTORNEY.

G. W. WOOD.  
ROTARY ENGINE.  
APPLICATION FILED NOV. 18, 1901.

NO MODEL.

3 SHEETS—SHEET 2.

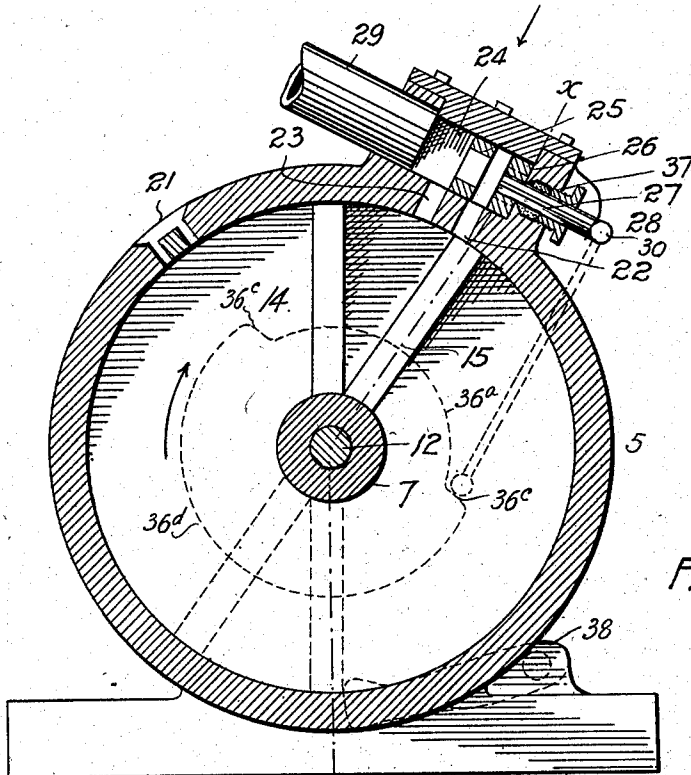

FIG. 3

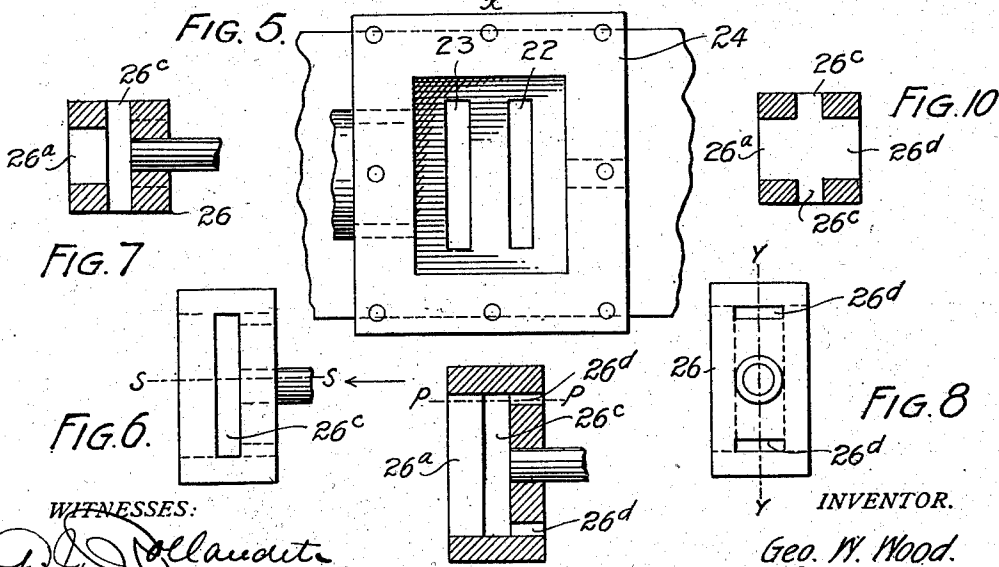

FIG. 5.

FIG. 7

FIG. 6.

FIG. 8

FIG. 9

FIG. 10

WITNESSES:

*J. J. Ollaudite*  
*Dena Nelson.*

INVENTOR.

Geo. W. Wood.

BY *A. J. [Signature]*  
ATTORNEY.

G. W. WOOD.  
ROTARY ENGINE.

APPLICATION FILED NOV. 18, 1901.

NO MODEL.

3 SHEETS—SHEET 3.

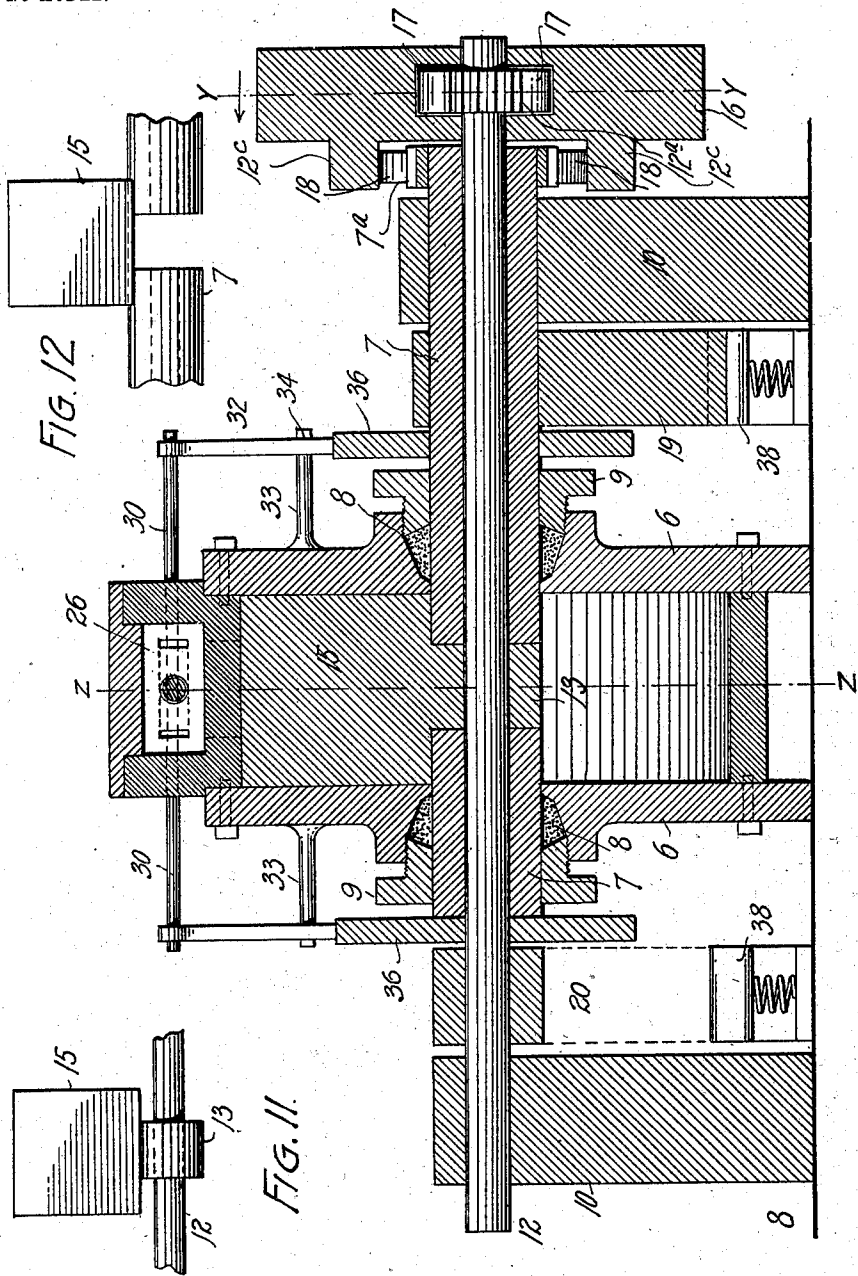

WITNESSES:  
*J. J. Delandret*  
*Dena Nelson*

INVENTOR.  
 Geo. W. Wood.  
 BY *[Signature]*  
 ATTORNEY.

# UNITED STATES PATENT OFFICE.

GEORGE W. WOOD, OF DENVER, COLORADO.

## ROTARY ENGINE.

SPECIFICATION forming part of Letters Patent No. 719,969, dated February 3, 1903.

Application filed November 18, 1901. Serial No. 82,775. (No model.)

*To all whom it may concern:*

Be it known that I, GEORGE W. WOOD, a citizen of the United States of America, residing at Denver, in the county of Arapahoe and State of Colorado, have invented certain new and useful Improvements in Rotary Engines; and I do declare the following to be a full, clear, and exact description of the invention, such as will enable others skilled in the art to which it appertains to make and use the same, reference being had to the accompanying drawings, and to the figures of reference marked thereon, which form a part of this specification.

My invention relates to improvements in rotary engines; and it consists of the features, arrangements, and combinations hereinafter described and claimed, all of which will be fully understood by reference to the accompanying drawings, in which is illustrated an embodiment thereof.

In the drawings, Figure 1 is an end elevation of my improved engine, the smaller concentric shaft being shown in section. Fig. 2 is a section taken on the line *y y*, Fig. 4, viewed in the direction of the arrow. Fig. 3 is a vertical section taken on the line *z z*, Fig. 4. Fig. 4 is a section taken on the line *x x*, Fig. 3. Fig. 5 is a top view of the valve-chest with the cap-plate removed. Fig. 6 is a plan view of the valve or a view taken in the direction of the arrow in Figs. 1 and 3, the cap-plate of the valve-chest being removed. Fig. 7 is a section taken on the line *s s*, Fig. 6. Fig. 8 is an end view of the valve or a view taken in the direction of the arrow in Fig. 6. Fig. 9 is a section taken on the line *w w*, Fig. 8. Fig. 10 is a section taken on the line *p p*, Fig. 9. Figs. 11 and 12 are detail views of the paddles and their respective shafts shown on a smaller scale.

The same reference characters indicate the same parts in all the views.

Let the numeral 5 designate a cylinder to which are applied heads 6, having base portions 6<sup>a</sup>, arranged to give the cylinder a stable support in the proper position. A hollow shaft 7 is passed through the axial center of the cylinder, engaging central registering openings formed in the heads 6, which are provided with suitable stuffing-boxes. As shown in the drawings, the heads are pro-

vided with cavities which are filled with Babbitt metal 8, against which are screwed the glands 9, making fluid-tight joints around the hollow shaft. Through the longitudinal opening of this shaft is passed a shaft 12, the two shafts being concentrically arranged. The shafts 7 and 12 are arranged to move independently of each other. Uprights 10, forming bearings for the shafts, are located at the respective extremities of the machine. The shaft 7 is journaled in the cylinder-heads and in one of these bearings. The shaft 7 is divided within the cylinder to make room for a collar 13, belonging to a plate or paddle 15, which extends axially from the shaft 12 and fits the cylinder nicely, as shown in Fig. 4. Another similar plate or paddle (designated 14) is located within the cylinder and connects the two parts of the hollow shaft 7. The extremity of each shaft farther to the right in Fig. 4 is provided with a ratchet-collar, that on shaft 7 being designated 7<sup>a</sup>, while that on the shaft 12 is designated 12<sup>a</sup>. Mounted on the ratchet extremity of the shaft 12 is a pulley 16, which is provided with a central circular cavity in which are located spring-held dogs 17, the arrangement being such that when the shaft 12 is rotated in the direction indicated by the arrow in Fig. 2 its ratchet will engage the dogs and rotate the pulley. The inner surface of this pulley (see Fig. 4) is provided with a circular flange or collar 12<sup>c</sup>, on which are located spring-held dogs 18. This collar surrounds the ratchet 7<sup>a</sup> and the ratchet is arranged to engage the said dogs and rotate the pulley 16 when the shaft 7 is traveling in the direction indicated by the arrow in Fig. 2.

It is evident from the construction described, referring especially to Figs. 2 and 4, that either shaft may rotate the pulley while the other shaft remains stationary. Hence if either shaft is rotated the pulley will be operated.

The shafts 7 and 12 are respectively provided with weights 19 and 20, located outside of the cylinder and oppositely arranged from the paddles 14 and 15. These weights are of the same gravity and serve to counterbalance the paddles.

The cylinder is provided with an exhaust-port 21 and two inlet-ports 22 and 23. Out-

side of the inlet-ports is located a valve-chest 24, closed at the top by a cap 25. Within this valve-chest is located a slide-valve 26, provided with a stem 27, passing through a stuffing-box 28, mounted on one extremity of the valve-chest. The opposite extremity of the valve-chest is open to communicate with a conduit 29 for delivering the necessary fluid (air or steam) to the cylinder. The outer extremity of the valve-stem is connected with two rods 30, extending outwardly therefrom in opposite directions. Each of these rods is connected with a lever 32, fulcrumed, as shown at 34, on a projection 33, mounted on the adjacent cylinder-head. The free extremity of each lever is provided with an antifrictional roller 35 and adapted to engage a cam-disk 36. One cam-disk 36 is made fast to the shaft 7 and the other to the shaft 12. Each disk is provided with a reduced part 36<sup>a</sup>, at each extremity of which is located an abrupt shoulder or offset 36<sup>c</sup>. When the inner extremity of the lever is in engagement with the part 36<sup>a</sup> of the disk, the valve 26 is held open by the action of a spring 37; but as soon as this extremity of the lever is forced outwardly by the shoulder 36<sup>a</sup> to engagement with the larger part 36<sup>d</sup> of the cam-disk the outer extremity of the lever is forced inwardly sufficiently to close the valve.

Assuming that the parts are in the relative position shown in Figs. 1 and 3, the lower extremity of each lever 32 has just left the larger part of the cam and passed to engagement with its smaller part, allowing the valve 26 to open through the action of the spring 37. The paddles 14 and 15 are then in the relative position shown in full lines in Fig. 3 and by dotted lines in Fig. 1—that is to say, the paddle 14 has passed the exhaust-port and continued to move by momentum sufficiently to force the paddle 15 to pass the outlet-port 23. The counterweight 20 of the paddle 14 has in this event moved to engagement with the holding extremity of a spring-actuated dog 38, which locks the paddle 14 against rearward movement or against movement in the direction opposite that indicated by the arrow in Figs. 1 and 3. Live steam entering the cylinder by way of the ports 22 and 23 acts on the paddle 15, driving the latter forward until it passes the exhaust-port 21 and moves the paddle 14 past the port 23. The paddle 15 will then cease to move forward and be held by another dog 38, acting on the counterweight 19, against backward movement. The paddle 14 will then be actuated in the same manner, the paddles being alternately operated in the cylinder, as will be readily understood. The movement of the paddles actuates the shafts 7 and 12, imparting a continuous revolution to the pulley 16, from which power may be transmitted to the apparatus to be operated.

The valve 26 is perfectly balanced. It is provided with a cavity 26<sup>a</sup> in front or facing the inlet-opening of the valve-chest. This

front opening communicates with a port or passage 26<sup>c</sup>, extending through the valve from top to bottom and arranged to register with the inlet-port 22 of the cylinder when the valve is open. This valve is provided with two ports 26<sup>d</sup>, extending rearwardly from the port 26<sup>c</sup>, through which the fluid passes to the rear of the valve, making the pressure equal on both sides, whereby the valve is perfectly balanced, requiring very little power for its operation. By reason of having two inlet-ports only half the movement of the valve is required to open and close the port that would be necessary if a single inlet-port of double the width or of the same capacity as the two ports were employed.

Having thus described my invention, what I claim is—

1. The combination with a cylinder provided with suitable inlet and exhaust ports, of two concentrically-arranged shafts passing through the cylinder, a paddle connected with each shaft and extending radially therefrom, the two paddles being arranged to operate alternately, the position of rest of the idle paddle being between the inlet and exhaust ports, the inner extremity of the active paddle adjacent the shaft, after its outer extremity passes the exhaust-port, engaging the inner extremity of the idle paddle and moving the latter past the inlet-port, the distance between the position of rest and the exhaust-port being sufficient to allow the active paddle to pass the exhaust-port before engaging the idle paddle, the arrangement being such that the momentum of the active paddle as it approaches the position of rest, moves the idle paddle from said position to a position forward of the inlet-port in the direction of the travel.

2. In a rotary engine, the combination with a cylinder, of two concentrically-arranged shafts passing therethrough, the cylinder being provided with suitable inlet and exhaust ports, a paddle attached to each shaft, and located within the cylinder, the paddles being arranged to operate alternately and cooperate, substantially as described, counterweights for the paddles, said weights being attached to their respective shafts outside of the cylinder, a cam mounted on each shaft and outside of the cylinder, a valve for controlling the inlet-port, and a suitable connection between the valve and each cam, whereby the valve is operated at properly-timed intervals, substantially as described.

3. The combination with a cylinder provided with suitable inlet and exhaust ports, of two concentrically-arranged shafts passing axially therethrough, a paddle extending radially from each shaft, the two paddles being arranged to operate alternately, the position of rest of the idle paddle being between the inlet and the exhaust ports, means for locking the paddle against rearward movement, a cam mounted on each shaft outside of the cylinder, a valve for controlling the inlet-

port, and a suitable connection between the valve and each cam, whereby the valve is operated at properly-timed intervals, substantially as described.

5 4. The combination with a cylinder provided with suitable inlet and exhaust ports, of two concentric shafts passing through the cylinder, a paddle extending radially from each shaft, the two paddles being  
10 arranged to operate alternately, the position of rest of the idle paddle being between the inlet and the exhaust ports, a counterweight for each paddle connected with the respective shafts outside of the cylinder, and a dog  
15 adapted to engage the counterweight of the idle paddle and lock the latter against rearward movement.

5 5. In a rotary engine, the combination with a cylinder, having suitable inlet and exhaust  
20 ports, of two concentric shafts passed axially through the cylinder, a paddle attached to each shaft, the two paddles being arranged to operate alternately and operate their respective shafts in the same direction, a cam  
25 mounted on each shaft outside of the cylinder, a valve for controlling the inlet-port, and a suitable connection between the valve and each cam, whereby the valve is operated  
30 at properly-timed intervals, substantially as described.

6. In a rotary engine, the combination with a cylinder having suitable inlet and exhaust ports, and two concentric shafts passed axially through the cylinder, the two paddles  
35 being arranged to operate alternately and actuate their respective shafts, a cam mounted on each shaft outside of the cylinder which is provided with a valve-chest, a valve located in said chest and provided with a pro-

jecting stem, and two levers connected with  
40 the valve and arranged to be respectively and alternately operated by the cams of the shafts.

7. In a rotary engine, the combination with a cylinder having suitable inlet and exhaust  
45 ports, of two concentric shafts passed axially through the cylinder, a paddle attached to each shaft, the two paddles being arranged to operate alternately and actuate their respective shafts, a cam mounted on each shaft out-  
50 side of the cylinder, which is provided with a valve-chest, a balanced valve located within the valve-chest, means for normally holding the valve open, and a suitable connection  
55 between the valve and the cams of the respective shafts, whereby the valve is closed at properly-timed intervals.

8. In a rotary engine, the combination with a cylinder, of two concentric shafts passing  
60 therethrough axially, a paddle attached to each shaft, the two paddles being arranged to be alternately actuated, whereby the shafts are alternately active and idle, a wheel for transmitting motion from the shafts, each  
65 shaft having a circular ratchet fast thereon, and two sets of dogs annularly arranged with reference to the ratchets of the respective shafts, and engaging said ratchets, whereby  
70 the rotation of either shaft imparts motion to the wheel in a given direction while the other shaft remains idle, substantially as described.

In testimony whereof I affix my signature in presence of two witnesses.

GEORGE W. WOOD.

Witnesses:

DENA NELSON,  
A. J. O'BRIEN.