

(19) World Intellectual Property
Organization
International Bureau



(43) International Publication Date
30 September 2004 (30.09.2004)

PCT

(10) International Publication Number
WO 2004/084166 A2

(51) International Patent Classification⁷: G09G

1EH (GB). CROSTHWAITE, Julia [GB/GB]; i-Dare Innovation Limited, Unit 1, Elvingston Science Centre, Gladsmuir, East Lothian EH33 1EH (GB).

(21) International Application Number:
PCT/GB2004/001237

(74) Agent: KENNEDYS PATENT AGENCY LIMITED;
Floor 5, Queens House, 29 St. Vincent Place, Glasgow G1 2DT (GB).

(22) International Filing Date: 22 March 2004 (22.03.2004)

(25) Filing Language: English

(26) Publication Language: English

(30) Priority Data:
0306555.4 21 March 2003 (21.03.2003) GB

(81) Designated States (unless otherwise indicated, for every kind of national protection available): AE, AG, AL, AM, AT, AU, AZ, BA, BB, BG, BR, BW, BY, BZ, CA, CH, CN, CO, CR, CU, CZ, DE, DK, DM, DZ, EC, EE, EG, ES, FI, GB, GD, GE, GH, GM, HR, HU, ID, IL, IN, IS, JP, KE, KG, KP, KR, KZ, LC, LK, LR, LS, LT, LU, LV, MA, MD, MG, MK, MN, MW, MX, MZ, NA, NI, NO, NZ, OM, PG, PH, PL, PT, RO, RU, SC, SD, SE, SG, SK, SL, SY, TJ, TM, TN, TR, TT, TZ, UA, UG, US, UZ, VC, VN, YU, ZA, ZM, ZW.

(71) Applicant (for all designated States except US): i-DARE INNOVATION LIMITED [GB/GB]; Unit 1, Elvingston Science Centre, Gladsmuir, East Lothian EH33 1EH (GB).

(72) Inventors; and

(75) Inventors/Applicants (for US only): OSIGWE, Godwin, Okechukwn [—/GB]; i-Dare Innovation Limited, Unit 1, Elvingston Science Centre, Gladsmuir, East Lothian EH33

(84) Designated States (unless otherwise indicated, for every kind of regional protection available): ARIPO (BW, GH,

[Continued on next page]

(54) Title: DISPLAY DEVICE

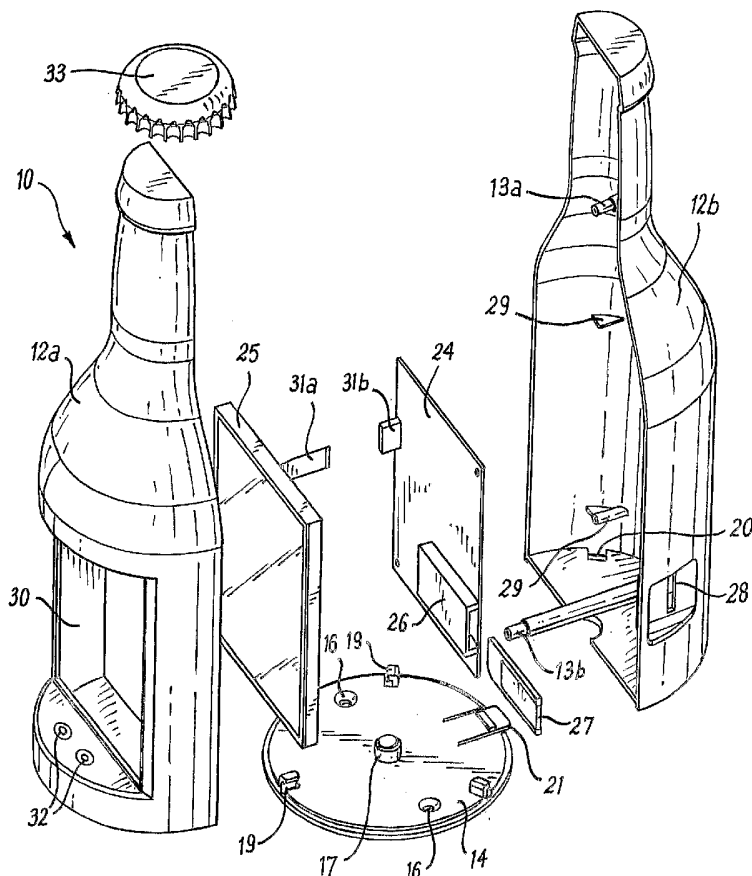

(57) Abstract: An electronic display device and associated system and method is described. In one embodiment, the device is formed as a product replica, having an LCD screen embedded therein for displaying video content. The device has a footprint identical to products in a display area, allowing incorporation of the device into the display with minimal disruption. Arrangements for updating the data content of the device from portable devices or from web-based material are also described.

WO 2004/084166 A2



GM, KE, LS, MW, MZ, SD, SL, SZ, TZ, UG, ZM, ZW), Eurasian (AM, AZ, BY, KG, KZ, MD, RU, TJ, TM), European (AT, BE, BG, CH, CY, CZ, DE, DK, EE, ES, FI, FR, GB, GR, HU, IE, IT, LU, MC, NL, PL, PT, RO, SE, SI, SK, TR), OAPI (BF, BJ, CF, CG, CI, CM, GA, GN, GQ, GW, ML, MR, NE, SN, TD, TG).

Published:

— *without international search report and to be republished upon receipt of that report*

For two-letter codes and other abbreviations, refer to the "Guidance Notes on Codes and Abbreviations" appearing at the beginning of each regular issue of the PCT Gazette.

1 **Display device**

2

3 The present invention relates to the field of electronic
4 display devices, and in particular electronic display
5 devices for recording, storage and playback of multimedia
6 content such as digital video, audio, and text.

7

8 Retail outlets such as grocery stores and supermarkets
9 stock an increasing variety of products. Of these
10 products, many are different brands for competing,
11 similar goods. Promotion of these competing brands in-
12 store is typically restricted to product labelling and
13 packaging. Additional information such as nutritional
14 information, recipe ideas etc must also compete with the
15 branding cereal on the product itself.

16

17 Alternative promotion techniques include placing leaflets
18 or cards in dispensers located close to the product.
19 However, these leaflets are similarly limited in the
20 amount of information that they can contain, and rely on
21 the consumer noticing the dispenser and removing a
22 leaflet.

23

1 Advertising posters may also be used in stores in order
2 to promote various products. However, the posters
3 require a significant flat surface, which severely limits
4 the positions in which they could be used. In addition,
5 since the posters are static media they may not
6 adequately get the attention of consumers. Furthermore,
7 the posters must be taken down and replaced with printed
8 posters should the product ranges or particular offers
9 change.

10

11 More eye-catching are the plasma screens positioned
12 around retail outlets for displaying and advertising a
13 wide range of products in a given store. The size of
14 these plasma displays precludes their placement in
15 amongst the products themselves; they are generally
16 placed in elevated positions at central areas of the
17 store. Plasma displays are often expensive. In
18 addition, they require connection to external equipment
19 in order to provide a display.

20

21 It would therefore be desirable to provide an improved
22 media for displaying promotional material in a retail
23 environment, and to at least mitigate some of the
24 drawbacks of the prior art.

25

26 It is an aim of one aspect of the present invention to
27 provide an electronic display device that provides
28 improved integration into retail environments.

29

30 It is an aim of one aspect of the invention to provide a
31 device that allows brand reinforcement at the point of
32 sale. In the context of this description, point of sale
33 should be interpreted as meaning the location at which a

1 product is purchased, selected, displayed or offered for
2 disposal.

3

4 Offering for disposal should be interpreted broadly to
5 cover offering for sale, hire, order, or free sampling.

6

7 Further aims and objects of the present invention will
8 become apparent from a reading of the following
9 description.

10

11 According to a first aspect of the invention, there is
12 provided an electronic display device comprising:

- 13 - a housing;
- 14 - data storage means;
- 15 - data processing means;
- 16 - a display screen mounted to the housing;
- 17 - means for securing the device at a point of sale;
- 18 - wherein the housing is moulded in the shape of a
19 product offered for disposal at the point of sale.

20

21 According to a second aspect of the invention, there is
22 provided an electronic display device comprising:

- 23 - a housing moulded in the shape of a product offered for
24 disposal at a point of sale;
- 25 - a display screen mounted within the housing;
- 26 - data storage means;
- 27 - data processing means;
- 28 - means for securing the device at the point of sale.

29

30 According to a third aspect of the invention, there is
31 provided an electronic display device comprising:

- 32 - a housing;
- 33 - data storage means;

- 1 - data processing means;
2 - a display screen mounted to the housing;
3 - means for securing the device at a point of sale;
4 - wherein the housing is incorporated as part of a
5 dispenser for a beverage offered for disposal at the
6 point of sale.

7

8 Preferably, the electronic display device is capable of
9 displaying digital video content.

10

11 The housing may be moulded to the approximate dimensions
12 of the product offered for disposal at the point of sale.

13

14 The electronic display device may be provided with a
15 loudspeaker to enable the output of audio content.

16

17 Preferably, the device further comprises a wireless
18 transceiver for receiving or transmitting data from or to
19 a remote device.

20

21 Preferably, the remote device is a portable unit having a
22 wireless transceiver for receiving or transmitting data
23 from or to the electronic display device.

24

25 Preferably, the electronic display device is secured to a
26 shelf for displaying products offered for disposal.

27

28 The housing may be provided with a slot for the
29 insertion/or removal of a removable memory storage unit.

30

31 The display may be a LCD module with a 320x480-pixel
32 matrix.

33

1 The housing may comprise a plurality of part housings,
2 each part housing being provided with corresponding
3 engaging means.

4

5 Preferably, the means for securing the device at the
6 point of sale is a base plate having fixings for
7 attachment at the point of sale.

8

9 The housing may be provided with engagement means for
10 releasably engaging with corresponding engagement means
11 provided on the base plate.

12

13 The engagement means may be a plurality of apertures and
14 corresponding resilient snap connectors.

15

16 The engagement means may be provided with a locking
17 mechanism, for retaining engagement, the locking
18 mechanism being releasable upon interaction with a
19 cooperating key.

20

21 The housing may be provided with a slot for the
22 insertion/or removal of a removable memory storage unit.

23

24 The display may be a LCD module with a 320x480-pixel
25 matrix.

26

27 The electronic display device may be provided with an
28 interface for enabling interaction by a user.

29

30 The interface may be a touch-screen. Alternatively, the
31 interface may be a keypad.

32

1 The housing may comprise a plurality of part housings,
2 each part housing being provided with corresponding
3 engaging means.

4

5 The housing may be shaped such that the footprint of the
6 electronic display device is substantially identical to a
7 product offered for disposal at a point of sale.

8

9 The housing may be substantially cylindrical in shape.

10

11 The housing may be bottle-shaped. Alternatively, the
12 housing may be can-shaped.

13

14 According to a fourth aspect of the invention, there is
15 provided an arrangement for electronic display comprising
16 at least one electronic display device, each electronic
17 display device having a housing, data storage means, data
18 processing means, a display screen mounted to the
19 housing, and means for securing the device at a point of
20 sale; and a portable data storage device communicable
21 with the electronic display device such that data is
22 transferable between the portable data storage and the
23 electronic display device.

24

25 The housing may be housing moulded in the shape of a
26 product offered for disposal at the point of sale.

27

28 The electronic display device may be provided with a
29 loudspeaker to enable the output of audio content.

30

31 Preferably, the electronic display device further
32 comprises a wireless transceiver for receiving or
33 transmitting data from or to a remote device.

1

2 Preferably, the portable data storage device is a
3 portable unit having a wireless transceiver for receiving
4 or transmitting data from or to the electronic display
5 device.

6

7 Preferably, the electronic display device is secured to a
8 shelf for displaying products offered for disposal.

9

10 The housing may be provided with a slot for the
11 insertion/or removal of a removable memory storage unit.

12

13 The portable data storage device may be provided with a
14 slot for the insertion/or removal of a removable memory
15 storage unit.

16

17 The display may be a LCD module with a 320x480-pixel
18 matrix.

19

20 The housing may comprise a plurality of part housings,
21 each part housing being provided with corresponding
22 engaging means.

23

24 Preferably, the means for securing the device at the
25 point of sale is a base plate having fixings for
26 attachment at the point of sale.

27

28 The housing may be provided with engagement means for
29 releasably engaging with corresponding engagement means
30 provided on the base plate.

31

32 The engagement means may be a plurality of apertures and
33 corresponding resilient snap connectors.

1

2 The engagement means may be provided with a locking
3 mechanism for retaining engagement, the locking mechanism
4 being releasable upon interaction with a cooperating key.

5

6 The housing may be provided with a slot for the
7 insertion/or removal of a removable memory storage unit.

8

9 The display may be a LCD module with a 320x480-pixel
10 matrix.

11

12 The electronic display device may be provided with an
13 interface for enabling interaction by a user.

14

15 The interface may be a touch-screen. Alternatively, the
16 interface may be a keypad.

17

18 The housing may comprise a plurality of part housings,
19 each part housing being provided with corresponding
20 engaging means.

21

22 The housing may be shaped such that the footprint of the
23 electronic display device is substantially identical to a
24 product offered for disposal at a point of sale.

25

26 The housing may be substantially cylindrical in shape.

27

28 The housing may be bottle-shaped. Alternatively, the
29 housing may be can-shaped.

30

31 There will now be described, by way of example only,
32 various embodiments of the invention with reference to
33 the following drawings, of which:

1

2 Figures 1a and 1b show an embodiment of the present
3 invention from perspective views;

4

5 Figure 2 shows an exploded view of the embodiment of
6 Figures 1a and 1b, and various components thereof;

7

8 Figure 3 shows an embodiment of the invention in use;

9

10 Figure 4 shows in schematic form the interaction of the
11 internal components of an embodiment of the invention;

12

13 Figure 5 shows a further aspect of the invention
14 including a plurality of electronic display devices in
15 situ;

16

17 Figure 6 shows an electronic display device in accordance
18 with an alternative embodiment of the invention from a
19 perspective view;

20

21 Figure 7 shows an exploded view of the embodiment of
22 Figure 6, and various components thereof;

23

24 Figure 8 shows a further alternative embodiment of the
25 invention;

26

27 Figure 9 shows in schematic form the interaction of the
28 internal components of an embodiment of the invention.

29

30 Referring firstly to Figures 1a, 1b and 2, a display
31 device is shown, generally depicted at 10. The device
32 includes a housing 12 comprising front and rear housing
33 portions 12a and 12b. The front and rear housing

1 portions are joined by screw guides 13a and 13b, which
2 extend across an interior cavity defined by the housing.
3 The ends of the screw guides 13a and 13b are received in
4 to corresponding sockets on the front housing 12a. The
5 screw guides define a bore into which a screw is
6 inserted. The screw securely fixes the front and rear
7 housing portions to one another.

8
9 It will be appreciated that alternate means of fixing the
10 front and rear housing portions could be used. For
11 example, fixing could be by integrally moulded snap
12 connectors.

13
14 The front and rear housing portions are positioned on a
15 base plate 14. The base plate 14 is provided with two
16 screw terminals 16 for securing the base plate to a fixed
17 structure such as a supermarket shelf. The base 14 is
18 provided with a central locating button 17 which
19 protrudes vertically from the base 14. A corresponding
20 semi-circular cut-out 18 is provided on each of the front
21 and rear housing portions 12a and 12b for receiving the
22 locating button 17 when the front and rear housing
23 portions are connected.

24
25 In addition, the base 14 includes resilient snap
26 connectors 19 for engaging with corresponding formations
27 20 provided on the housing portions. The snap connectors
28 19 engage the housing and secure it to the base, as well
29 as preventing it from rotating with respect to the base
30 14. In the example shown, three such snap connectors and
31 corresponding slots 20 are provided in the device. The
32 spacing of the connectors may be such that it is only
33 possible to fix the housing in one particular

1 orientation, i.e. with the front housing portion facing
2 in the correct direction.

3

4 The base 14 is also provided with a locking mechanism.
5 This is in the form of a resilient tongue 21, and
6 prevents the housing from being detached from the base
7 unit. A cooperating key is required in order to interact
8 with the locking mechanism 21 and so enable removing of
9 the housing and thereby access to the internal
10 components.

11

12 The housing defines a cavity for the internal components
13 of the device. The components include a circuit board 24
14 and a crystal display 25. The circuit board 24 includes
15 an audio-video graphics guard and appropriate data
16 processing components. In addition, the preferred
17 embodiment includes data storage components and a
18 Bluetooth[®] wireless chip capable of receiving data from
19 a remote Bluetooth[®] enabled device. A power supply for
20 the device is also required, which may be a rechargeable
21 battery pack.

22

23 The liquid crystal display (LCD) is a full colour, high
24 resolution TFT liquid crystal display module with, for
25 example a 320x480 pixel matrix.

26

27 In addition, the present embodiment includes a removable
28 memory card 27 and associated receiving socket 26. The
29 memory stick can be inserted into the socket when the
30 housing is assembled by virtue of the slots 28 provided
31 in the rear housing portion 12b. The memory card
32 receiving socket 26 is held in position by supports 29
33 provided in the rear housing 12b, which are aligned with

1 screw holes on the board 24. Similar supports are
2 provided in the front housing portions 12 for supporting
3 the LCD module 25. The LCD module is located such that
4 it is aligned with the window 30 provided in the front
5 housing. The LCD module is located such that it is fully
6 displayed through window 30, and it may be connected to
7 the circuit board via corresponding connectors 31a and
8 31b.

9

10 In the embodiments shown, the device is also provided
11 with a keypad comprising buttons 32. These buttons are
12 electronically connected to the circuit board 24 by leads
13 (not shown). A cap 33 completes the appearance of the
14 device.

15

16 The display device is shaped in the form of a replica
17 model of a product container. In the example shown, the
18 display device is bottle-shaped. The shape of the
19 container provides the device with substantially the same
20 dimensions as products on sale in the retail outlet.
21 This allows then to be positioned in amongst the products
22 without occupying an excessive amount of shelf space.

23

24 In addition, the shaping of the display device allows the
25 production of an exact, or near exact product replica.
26 For example, the display device can be provided with the
27 labelling, colouring and three-dimensional shape of a
28 particular brand of beer to be advertised.

29

30 Figure 3 shows the device 10 in use, being positioned on
31 a shelving unit 32 located in a retail outlet. The
32 display device 10, which in this example is bottle-
33 shaped, is placed in amongst a series of bottles 34. The

1 shape of the device enables it to be positioned on a
2 shelf, with the products themselves. The footprint of
3 the device 10 is substantially identical to the footprint
4 of the bottles 34. The device does therefore not take
5 out an excessive amount of valuable shelf space. The
6 device is positioned such that the LCD 25 is facing
7 outwards to the customers.

8

9 The electronic components of the device function to
10 display video material to the customers. In particular,
11 the display device runs a series of advertisements for
12 particular brands. The shape and size of the display
13 device enables it to be located alongside the product
14 that it advertises, and thus enables reinforcement of the
15 particular brands at the point of sale.

16

17 Figure 4 shows the interaction of the electrical
18 components of the display device in schematic form. The
19 diagram shows the system generally depicted at 40,
20 connected to a power supply 44. The power supply is for
21 example a rechargeable battery pack provided in the
22 housing of the device. Alternatively, the power supply
23 could be an external power source. The power supply
24 supplies necessary power for all of the components of the
25 device.

26

27 The system 40 includes memory unit 42 which in this
28 example is RAM having a 32 megabyte capacity. The memory
29 storage unit 42 stores data input to the device via
30 input/output 45. In particular, the memory storage unit
31 42 holds audio-visual data to the display LCD module 25,
32 and output via loudspeaker 47.

33

1 Block 41 is a data processing unit providing all the data
2 control and processing of the entire device. In
3 particular, the data processing unit 41 accesses memory
4 storage unit 42 to obtain the audio-visual data to be
5 displayed to the consumer.

6
7 Input/output 45 is a Universal Serial Bus (USB) port for
8 connecting an external device for updating the display
9 device and or accessing data recorded by the display
10 device.

11
12 Also shown in Figure 4 is Bluetooth[®] enabled chip 43.
13 The chip 43 allows wireless communication between the
14 display device 10 and an external Bluetooth[®] enabled
15 device. The Bluetooth[®] enabled chip 43 communicates
16 with the memory storage 42, so that data received by the
17 Bluetooth[®] enabled chip 43 can be retained in the
18 device. In addition, the Bluetooth[®] enabled chip 43
19 allows an external device to upload data from the display
20 device 10.

21
22 Also shown in Figure 4 is removable memory storage unit.
23 This is for example a removable memory card 27 as shown
24 in Figure 2. Arrows 46 represent the removal or
25 insertion of the removable memory card 27. When
26 inserted, the detachable memory unit 27 communicates with
27 the data processing unit 41 and the memory storage unit
28 42. The data processing unit 41 is able to access data
29 direct from the detachable memory storage unit 27. In an
30 alternative configuration, data may be transferred from
31 the detachable memory storage unit 27 to the memory
32 storage unit 42 for subsequent access by the data
33 processing unit 41. In this latter case, the detachable

1 memory storage unit 27 need not be left inserted in the
2 device.

3

4 Figure 4 also shows keypad 32 connected to the data
5 processing unit 41. The keypad 32 allows interaction of
6 the consumer device, as will be described in more detail
7 below.

8

9 The keypad 32 allows interaction between the display
10 device and an operator or a consumer. For example, the
11 display 25 may prompt a consumer to press a particular
12 button on the keypad in order to obtain more information
13 on the product advertised. The keys can operate a menu
14 driven system to allow the consumer to access, for
15 example, nutritional information, possible recipes for
16 the product, and or further information about the product
17 or related special offers. The keypad could also enable
18 a consumer to enter personal information to be included
19 on a mailing list or entered into a competition.

20

21 In addition, the keypad can enable the operator, who may
22 be an employee of the store or an external contractor to
23 configure the device.

24

25 Although the Figures show a keypad consisting of two
26 keys, it will be appreciated that alternative
27 configurations of the keypad may be used. In addition,
28 the LCD module may be a touch screen, allowing a consumer
29 or operator to directly select icons displayed on the
30 screen.

31

32 Figure 5 shows a plurality of display devices in use.
33 The display devices are mounted on the shelf in a retail

1 outlet by securely fixing the base 14 to the shelf. The
2 internal components and the housing are then fitted onto
3 the base to complete the product replica model form of
4 the display. Typically, several display devices will be
5 located at different positions in a store.

6
7 An operator, who may be an employee of the store or an
8 external contractor, updates the content of the memory in
9 the display devices. The operator carries a wireless
10 portable device including a bank of audio, video and text
11 data for the promotion of various products and brands.
12 The portable device is Bluetooth[®] enabled to allow
13 wireless transfer of data from portable device to the
14 display device. When the operator brings the portable
15 device within transmission/reception range of the display
16 device, he is able to update the memory content of the
17 display device with new promotional material. In
18 addition, the operator is able to download data from the
19 display device to the portable unit.

20
21 Although the description above gives Bluetooth[®] enabled
22 devices as the preferred embodiment, it will be apparent
23 to the skilled reader that other wireless transmission
24 methods are equally applicable.

25
26 In addition, data could be transferred from or to the
27 portable device to the display device by simply
28 transferring a removable memory card 27 from one device
29 to another. A yet further possibility is the transfer of
30 data from the portable device by a USB and appropriate
31 connectors.

32

1 The reader will appreciate that alternative shapes of
2 display device are possible. By way of example, Figures
3 6a, 6b and 7 show an alternative embodiment of the
4 invention. The embodiment shown in Figures 6a, 6b and 7
5 are similar to that shown in Figures 1a, 1b and 2, with
6 like components represented by the same reference
7 numerals. However, in the example of Figures 6a, 6b and
8 7, the display device is shaped as a food can.

9

10 Further alternative shapes are envisaged. For example,
11 the device may be shaped as a drinks can, a wine bottle,
12 a detergent bottle, a soap powder box, or any other type
13 of get-up or packaging for a product.

14

15 Figure 5 shows a number of display devices positioned in
16 a retail outlet. The retail outlet is in this example a
17 supermarket stocking a variety of products on shelf units
18 32. The different products include beverage bottles 34,
19 and soap powders or detergents 52. The Figure shows a
20 bottle-shaped display device 10 disposed amongst bottles
21 34. On a second shelf, additional display devices 51 are
22 positioned amongst the soap powder boxes and detergent
23 bottles, with each display being shaped as an adjacent
24 product.

25

26 In use, an operator 53 carries a portable device 54
27 capable of wirelessly transmitting and receiving data
28 from or to the display devices 10, 51. The portable
29 device comprises a bank of data, and the operator is able
30 to select the appropriate material for transmitting to a
31 display device. To enable the data to be controllably
32 transmitted to the display devices, the transmission
33 equipment may be directional, to avoid transmitting to

1 several display devices at once. Alternatively, the
2 transmission range of the portable device 54 can be less
3 than the separation between two display devices, so that
4 the data can only be transmitted to the display device
5 within range.

6

7 In the same manner, the operator can walk around the
8 store and upload data from the display devices. This can
9 enable data to be stored centrally for late analysis.

10

11 Figure 9 shows, schematically, an alternative embodiment
12 of the invention. In this arrangement, a number of
13 display devices, referred to as Digital Video Players
14 (DVP) 91 are provided in a retail outlet. Each DVP
15 comprises a Mini-ITX PC 92, which runs on a Linux
16 operating system. The PC 92 includes a wireless LAN card
17 93, for wireless connection to a suitable wireless router
18 94 placed within a distance of several meters away from
19 the computer 92. The computer also has a removable
20 memory device in the form of a compact flash card 95
21 capable of storing both video and text data, and a modem
22 connection 96 to allow transmission of data through
23 telephone lines. Liquid crystal display 97 is provided
24 for displaying video and text data.

25

26 Under normal operation, the Mini-ITX PC 92 will
27 interrogate, at pre-selected time intervals, a specified
28 website for availability of new audio-visual data. This
29 function is carried out as per the example below:

30

31 At pre-set times of 0900 hrs 1200 hrs, 1500 hrs, 1800
32 hrs, 2100 hrs 0000 hrs, the Digital Video Player (DVP) 91
33 will send an identification code to the wireless router

1 94 to identify itself. The signal is encrypted using the
2 Standard Wireless Encryption Protocol (WEP) to allow only
3 selected DVPs to connect to the Internet using this
4 particular router 94. Once identified, the router 94
5 allows the DVP to connect to a selected website, hosted
6 on a remote server 98. The router 94 also has to itself
7 have to identify itself to the website using the same WEP
8 or a specifically assigned ID for the DVP.

9
10 At the website, the unique ID will allow the DVP 91 to
11 download specific audio-visual or text data for the
12 specified DVP 91. This allows the regular, automated
13 updating of the display content from a remote location.
14 A bank of audio-visual/text material and product
15 information can be held at a single central location,
16 allowing configuration of individual displays at
17 different locations in a whole chain of retail outlets.

18
19 By providing each DVP 91 with modem 96, the process of
20 updating the content held in the DVP 91 and displayed to
21 consumers can also be carried out using conventional
22 broadband telephone lines.

23
24 Optionally, the router 94 can be used as an information
25 hub. An appropriately configured portable device such as
26 a Personal Digital Assistant 99 within the proximity of
27 the wireless router 94 will download relevant information
28 for display to an operator. For example, special offers
29 could be downloaded to a consumer from a retailer.

30
31 A further alternative embodiment of the invention is
32 shown in Figure 8. In this embodiment, the display
33 device is incorporated as part of a beverage dispenser in

1 a bar, public house or restaurant. The beverage
2 dispenser 81, commonly referred to as a beer font,
3 comprises a moulded housing 84 and a dispensing tap 83.
4 The moulded housing 84 is adapted to define an internal
5 cavity containing the internal components of the device.
6 The internal components are analogous to those shown in
7 the embodiment of Figures 1, 2, 6 and 7. A window 85 is
8 provided in the housing to allow an LCD 86 to display to
9 the user promotional material. The display device
10 incorporated into a beer font 81 is shown position on a
11 bar 87 adjacent to a conventional beer font 82.

12

13 In use, the LCD will display promotional material,
14 typically video clips, for advertising a beverage. A
15 consumer standing at the bar will be faced with a choice
16 of competing brands. The eye-catching nature of the
17 display located at the point of sale draws the attention
18 of the wavering consumer to a particular brand. The
19 brand is therefore reinforced at the point of sale.

20

21 The audio-visual content of the display device may be
22 updated by means of any of the techniques referred to
23 above. In particular, the beer fonts may be Bluetooth[®]
24 enabled to allow wireless transmission or reception of
25 data to or from a portable device. Alternatively, the
26 beer fonts may be networked with a central server or PC.

27

28 The present invention in its various aspects offers a
29 number of advantages and benefits. It offers an eye-
30 catching display to consumers in a compact form. The
31 shaping of the device allows it to be placed in amongst
32 the products offered for sale or offered for disposal,
33 without adversely effecting shelf displays. The device,

1 if it has the same footprint as the products will fit
2 easily into the product arrangement.

3

4 The device can be placed in amongst the products
5 discretely, so that it has the potential to surprise a
6 consumer when it catches their attention. In addition,
7 the device will not have a detrimental effect on the
8 display even when it is not being used.

9

10 The device allows reinforcement of the product or brand
11 at the point of sale itself, ie directly at the area at
12 which the consumer is faced with the product selection.

13

14 The device enables more information to be provided at the
15 point of sale. For example, the consumer is able to
16 access product data, such as recipe information, prize
17 draw details or other product information. In addition,
18 the provision of an interface would allow the device to
19 retrieve information and upload it to a central device.

20

21 Furthermore, the device can be readily configured or
22 updated by transferring audio, visual, or text data to or
23 from the device.

24

25 An electronic display device and associated system and
26 method is described. In one embodiment, the device is
27 formed as a product replica, having an LCD screen
28 embedded therein for displaying video content. The
29 device has a footprint identical to products in a display
30 area, allowing incorporation of the device into the
31 display with minimal disruption. Arrangements for
32 updating the data content of the device from portable
33 devices or from web-based material are also described.

1
2 Various changes, alterations, modifications and
3 improvements may be made to the above-described
4 embodiments within the scope of the invention herein
5 intended.

1 **Claims**

2

- 3 1. An electronic display device comprising:
- 4 - a housing;
- 5 - a display screen mounted to the housing;
- 6 - data storage means for storing visual content to
- 7 be displayed;
- 8 - data processing means for driving the display
- 9 screen;
- 10 - means for securing the device at a point of sale;
- 11 - wherein the housing is moulded in the shape of a
- 12 product offered for disposal at the point of sale.
- 13
- 14 2. The electronic display device as claimed in Claim 1
- 15 adapted to display digital video content.
- 16
- 17 3. The electronic display device as claimed in Claim 1
- 18 or Claim 2 wherein the housing is moulded to the
- 19 approximate dimensions of the product offered for
- 20 disposal at the point of sale.
- 21
- 22 4. The electronic display device as claimed in Claim 3
- 23 wherein the housing is shaped such that the
- 24 footprint of the electronic display device is
- 25 substantially identical to a product offered for
- 26 disposal at a point of sale.
- 27
- 28 5. The electronic display device as claimed in any
- 29 preceding Claim wherein the housing is substantially
- 30 cylindrical in shape.

31

- 1 6. The electronic display device as claimed in any
2 preceding Claim wherein the housing is bottle-
3 shaped.
4
- 5 7. The electronic display device as claimed in any of
6 Claims 1 to 5 wherein the housing is can-shaped.
7
- 8 8. The electronic display device as claimed in any
9 preceding Claim further comprising a wireless
10 transceiver for receiving or transmitting data from
11 or to a remote device.
12
- 13 9. The electronic display device as claimed in any
14 preceding Claim wherein the display is an LCD module
15 with a 320x480-pixel matrix.
16
- 17 10. The electronic display device as claimed in any
18 preceding Claim wherein the housing comprises a
19 plurality of part-housings, each part-housing being
20 provided with corresponding engaging means.
21
- 22 11. The electronic display device as claimed in any
23 preceding Claim wherein the means for securing the
24 device at the point of sale is a base plate having
25 fixings for attachment at the point of sale.
26
- 27 12. The electronic display device as claimed in Claim 11
28 wherein the housing is provided with engagement
29 means for releasably engaging with corresponding
30 engagement means provided on the base plate.
31
- 32 13. The electronic display device as claimed in Claim 12
33 wherein the engagement means is a plurality of

1 apertures and corresponding resilient snap
2 connectors.

3

4 14. The electronic display device as claimed in Claim 12
5 or Claim 13 wherein the engagement means is provided
6 with a locking mechanism for retaining engagement,
7 the locking mechanism being releasable upon
8 interaction with a cooperating key.

9

10 15. The electronic display device as claimed in any
11 preceding Claim wherein the housing is provided with
12 a slot for the insertion/or removal of a removable
13 memory storage unit.

14

15 16. The electronic display device as claimed in any
16 preceding Claim further comprising an interface for
17 enabling interaction by a user.

18

19 17. The electronic display device as claimed in Claim 16
20 wherein the interface is a touch-screen.

21

22 18. An electronic display device comprising:

23 - a housing;

24 - data storage means;

25 - data processing means;

26 - a display screen mounted to the housing;

27 - means for securing the device at a point of sale;

28 - wherein the housing is incorporated as part of a
29 dispenser for a beverage offered for disposal at
30 the point of sale.

31

32 19. A product display assembly comprising a display
33 structure supporting a plurality of products offered

1 for disposal, and an electronic display device
2 according to any preceding claim mounted to said
3 display structure.

4
5 20. A system for electronic display, the system
6 comprising at least one electronic display device,
7 each electronic display device having a housing,
8 data storage means, data processing means, a display
9 screen mounted to the housing, and means for
10 securing the device at a point of sale; and a
11 portable data storage device communicable with the
12 electronic display device such that data is
13 transferable between the portable data storage and
14 the electronic display device.

15
16 21. The system as claimed in Claim 20 wherein the
17 portable data storage device is a portable unit
18 having a wireless transceiver for receiving or
19 transmitting data from or to the at least one
20 electronic display device.

21
22 22. The system as claimed in Claim 20 or Claim 21
23 wherein the electronic display device is secured to
24 a shelf for displaying products offered for
25 disposal.

26
27 23. The system as claimed in any of Claims 20 to 22
28 wherein the electronic display device is provided
29 with a slot for the insertion/or removal of a
30 removable memory storage unit.

31
32 24. The system as claimed in any of Claims 20 to 23
33 wherein the portable data storage device is provided

1 with a slot for the insertion/or removal of a
2 removable memory storage unit.

3

4 25. The system as claimed in any of Claims 20 to 24
5 wherein the electronic display device is a device
6 according to any of Claims 1 to 18.

7

8 26. A system for electronic display comprising a
9 plurality of electronic display devices, each
10 electronic display device having data storage means,
11 data processing means, a display, and means for
12 securing the device at a point of sale; a wireless
13 router adapted to communicate with the plurality of
14 electronic display devices and access a remote
15 server, thereby allowing the content of the data
16 storage means to be updated with data from said
17 remote server.

18

19 27. The system as claimed in Claim 26 wherein the
20 wireless router is further adapted to communicate
21 with a portable data storage device.

22

23 28. The system as claimed in Claim 26 or Claim 27
24 wherein the electronic display device is a device
25 according to any of Claims 1 to 18.

26

27 29. A method of updating an electronic display device
28 having a having data storage means, data processing
29 means, a display, and means for securing the device
30 at a point of sale, the method comprising the steps
31 of:

- 1 - Interrogating, at a pre-selected time a remote
2 server in order to determine whether updated data
3 is available for the display device;
- 4 - Downloading updated data to the data storage means
5 from said remote server via the wireless router.
6
- 7 30. The method as claimed in Claim 29 comprising the
8 additional steps of:
- 9 - Issuing, at a pre-selected time, an identifier
10 signal from the display device to a wireless
11 router;
- 12 - Verifying in the wireless router that the display
13 device is authorised to receive updated data from
14 the remote server.
15

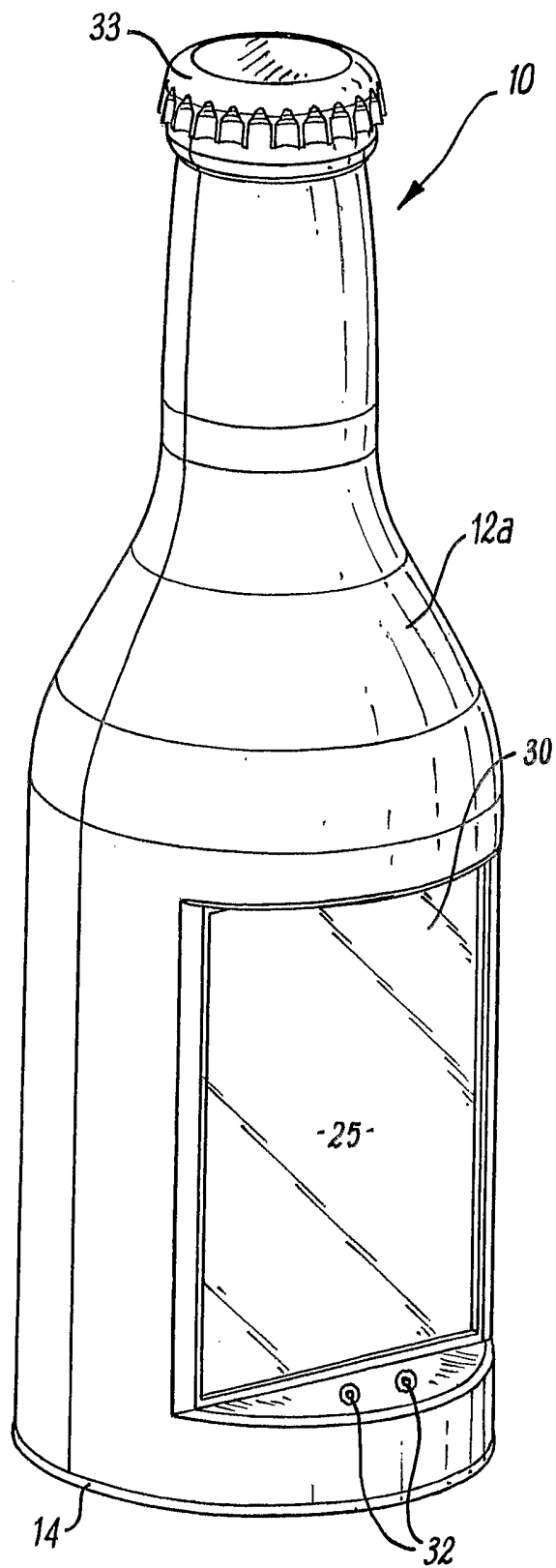

Fig. 1a

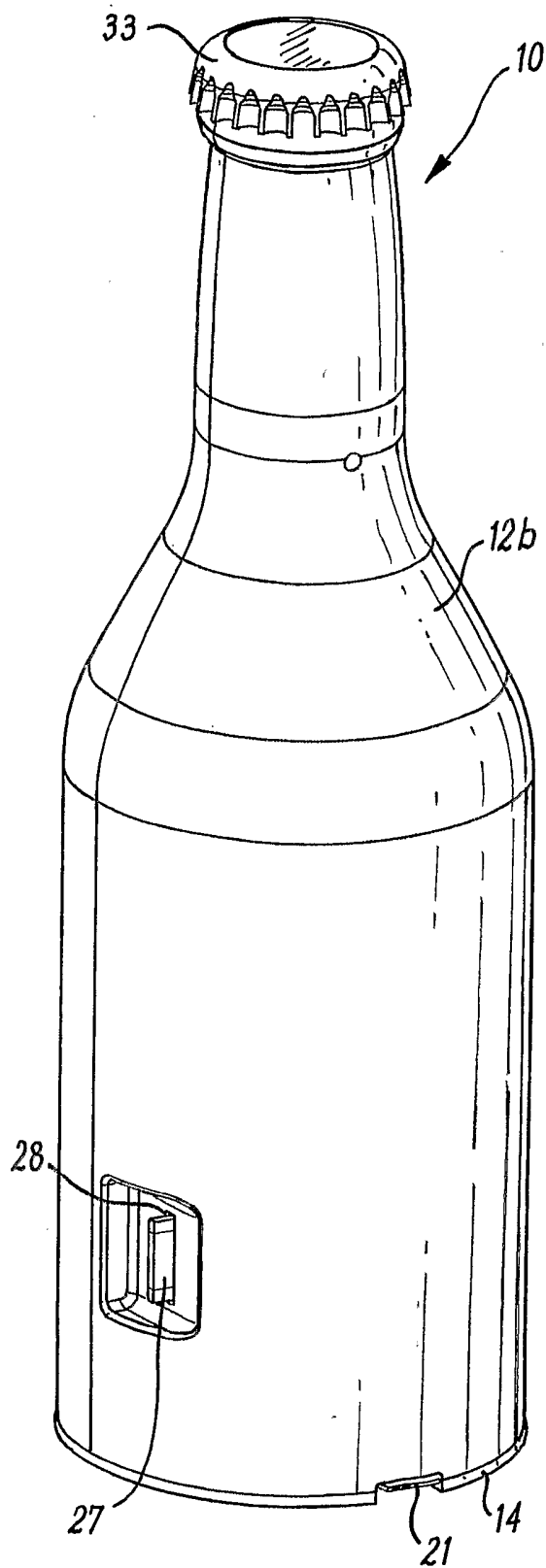

Fig. 1b

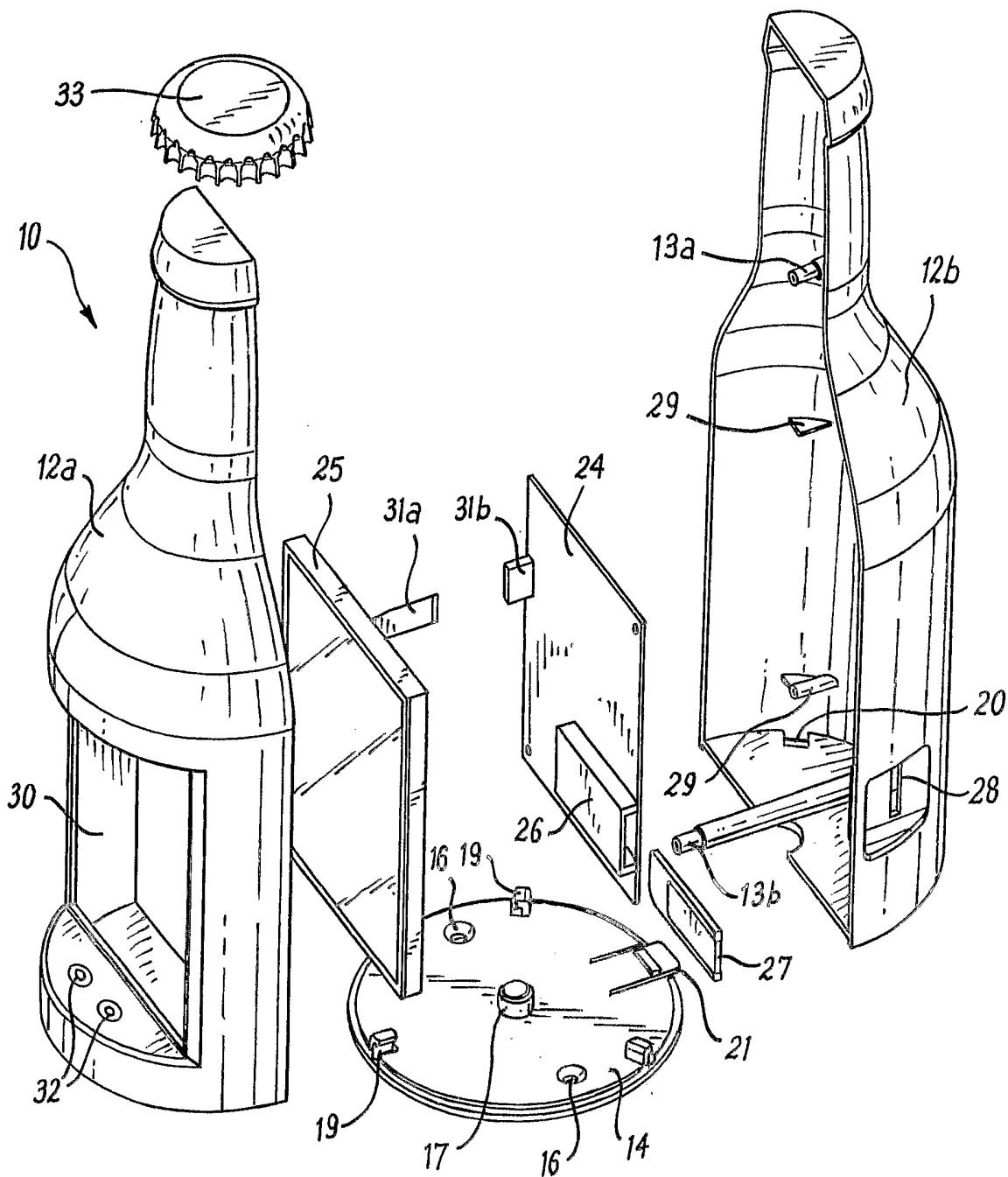

FIG. 2

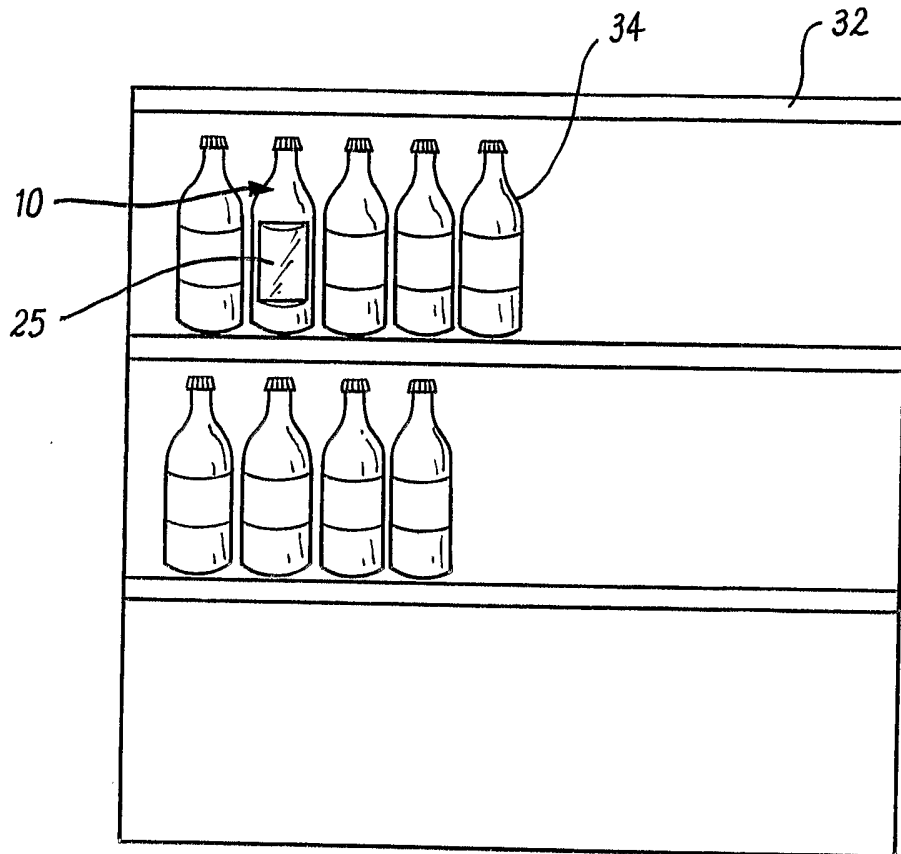

FIG. 3

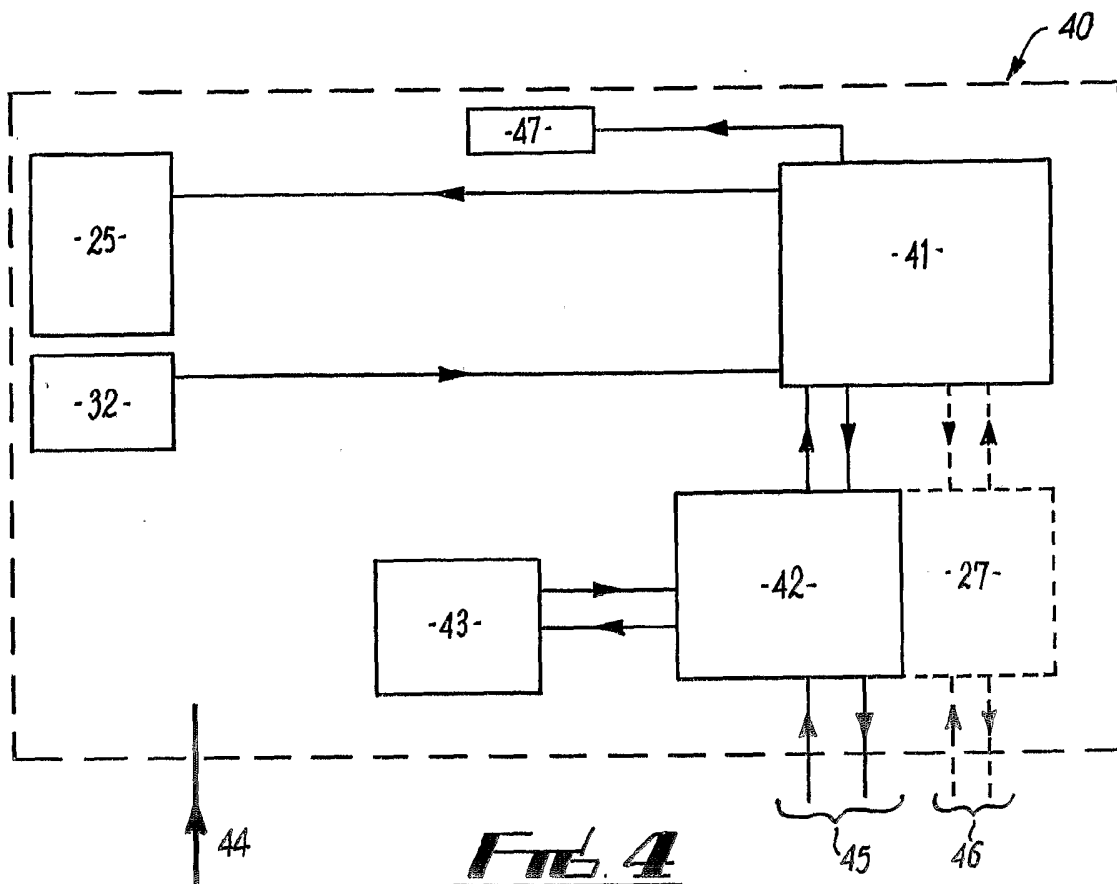

FIG. 4

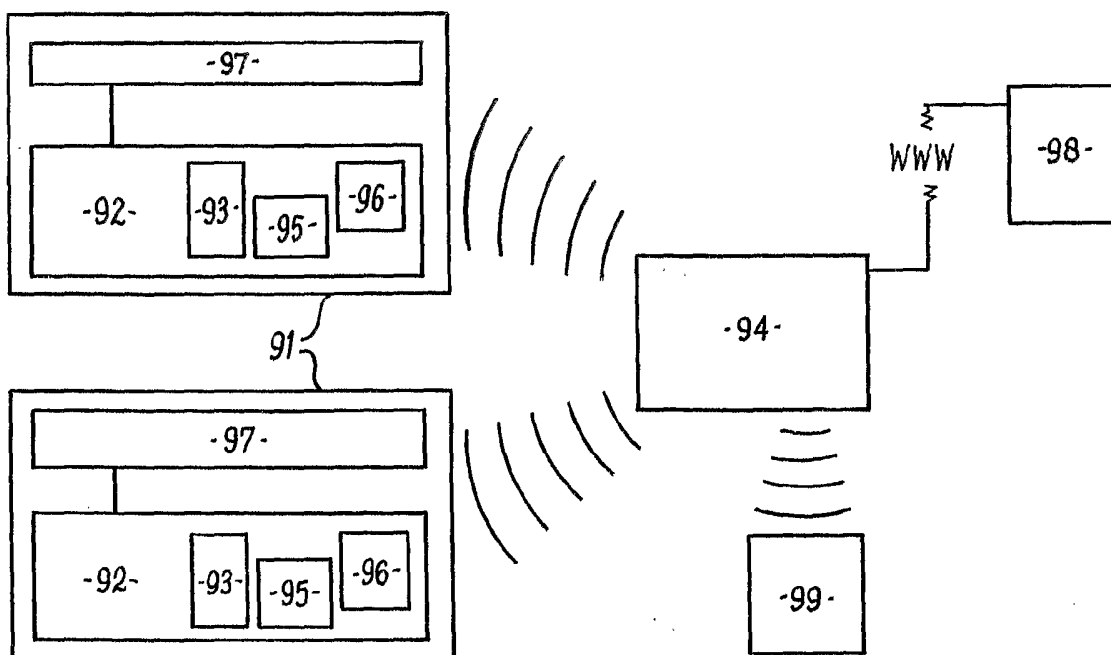

FIG. 9

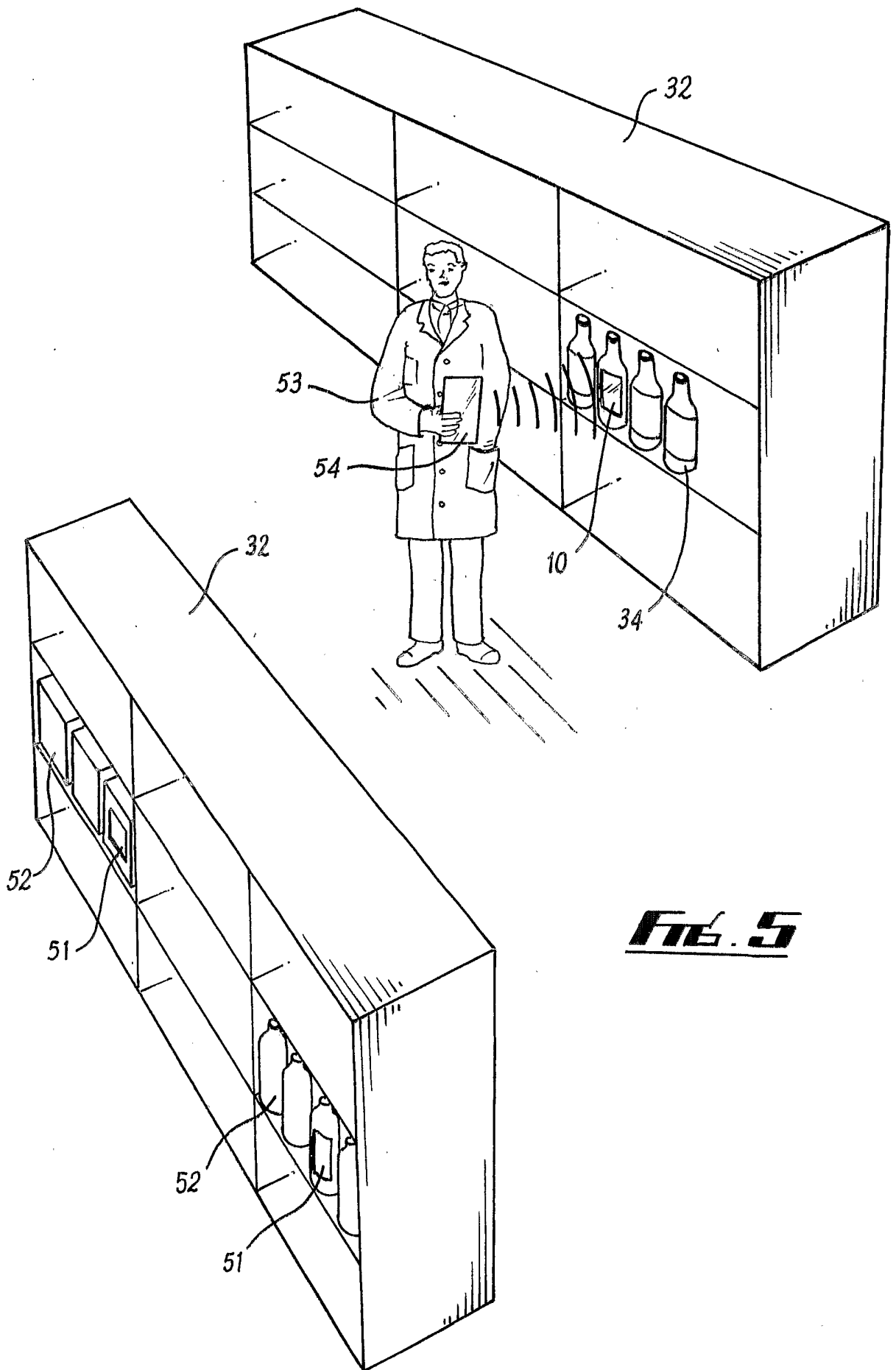

Fig. 5

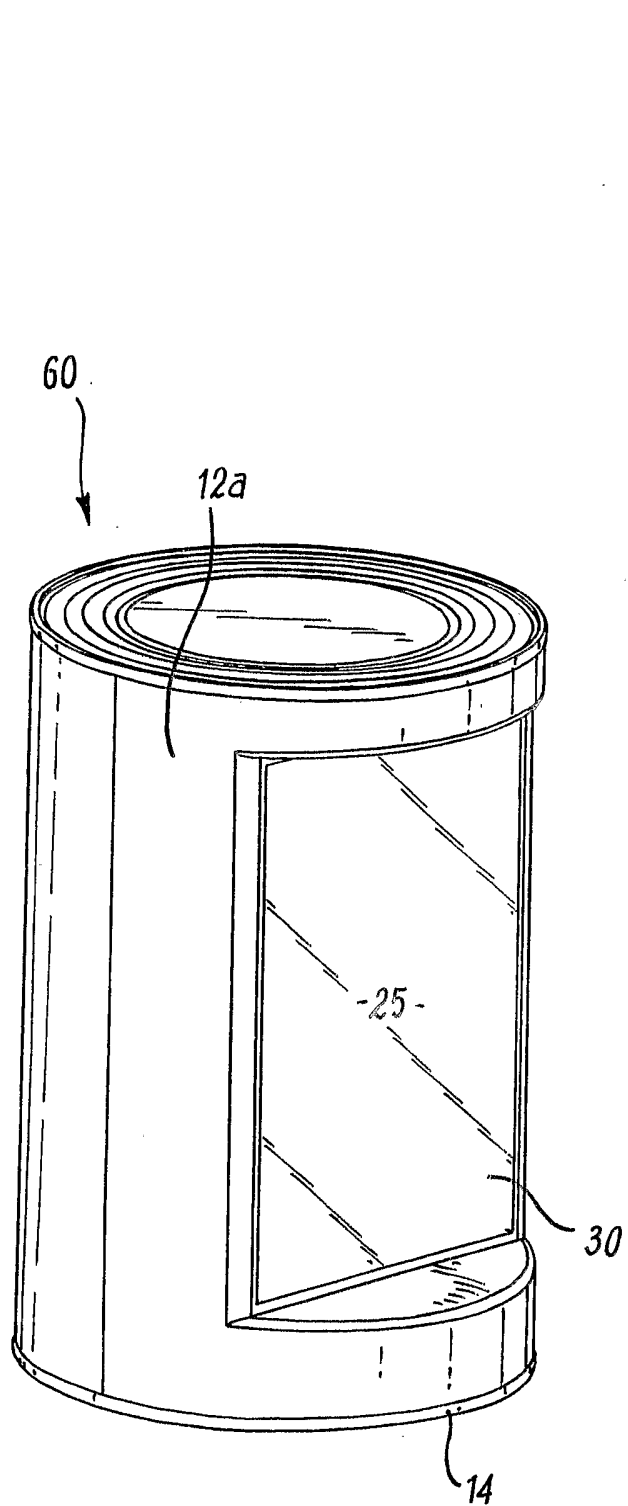

Fig. 6a

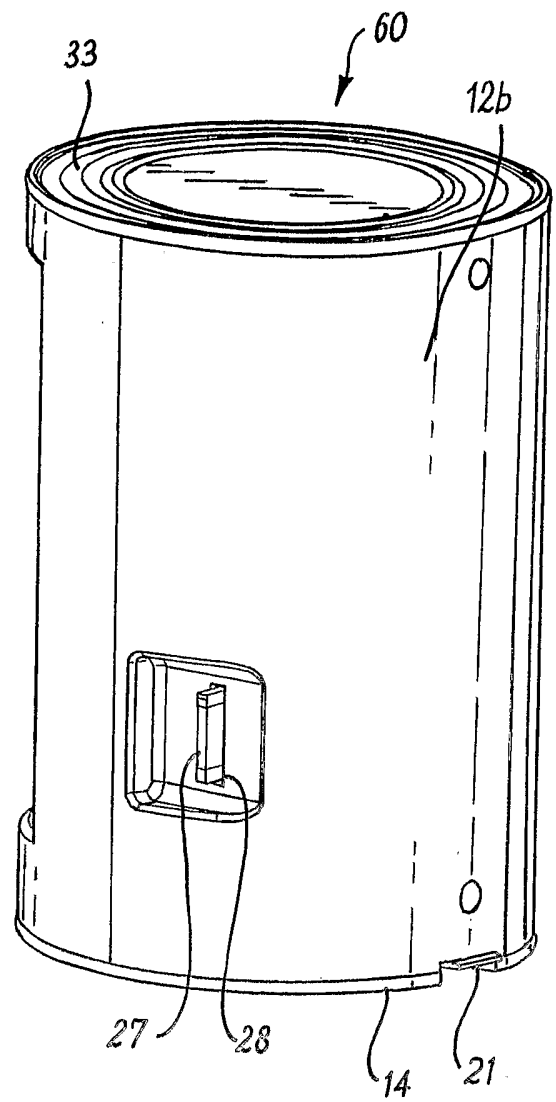

Fig. 6b

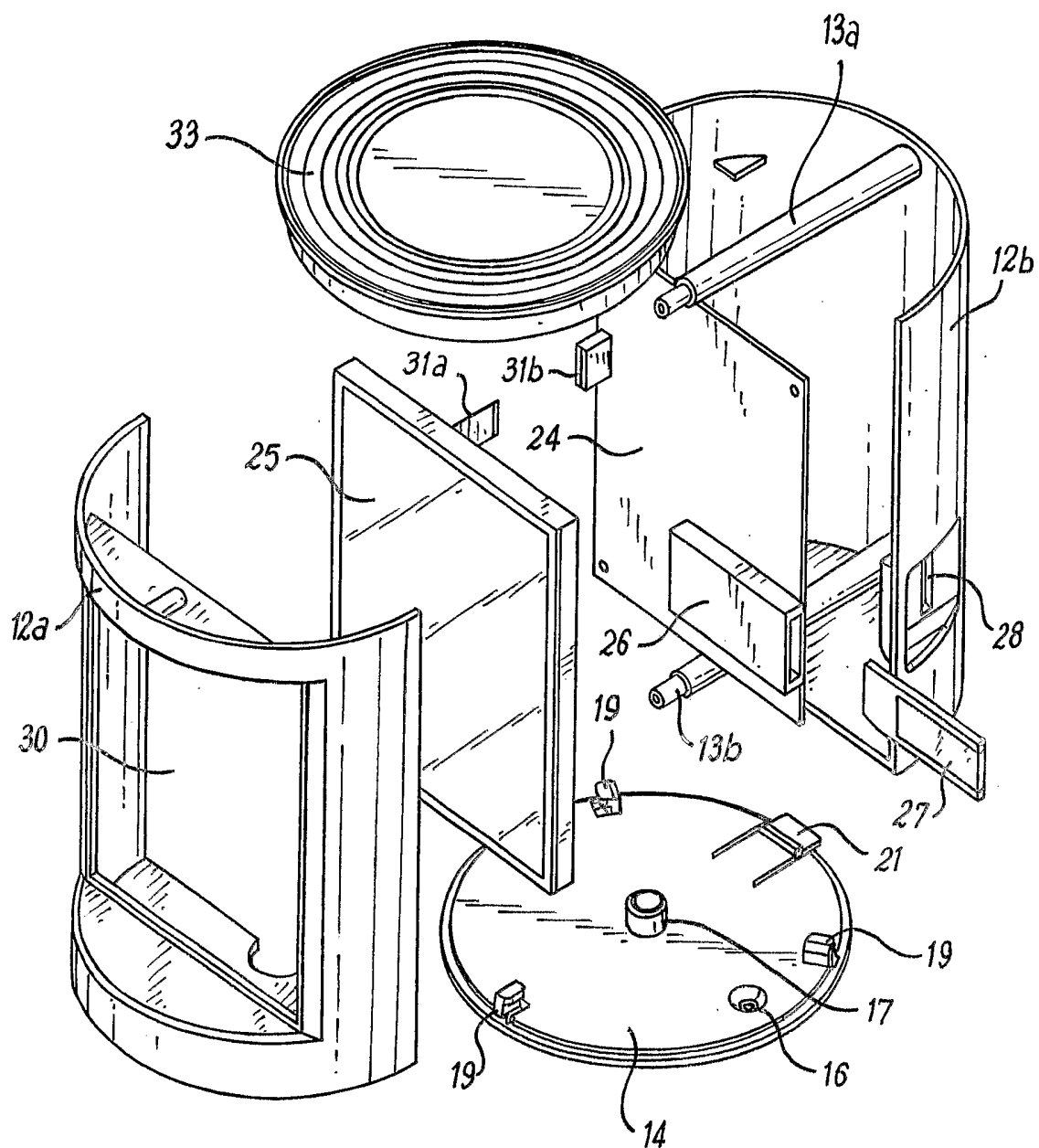

FIG. 7

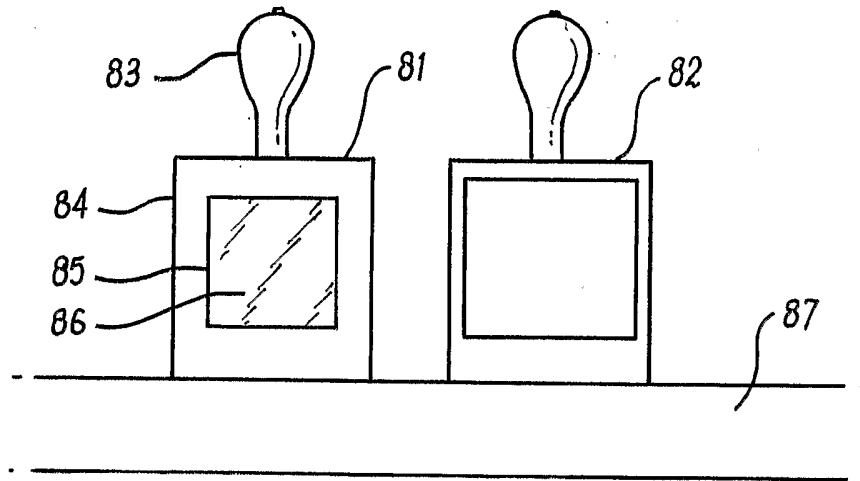

FIG. 8