

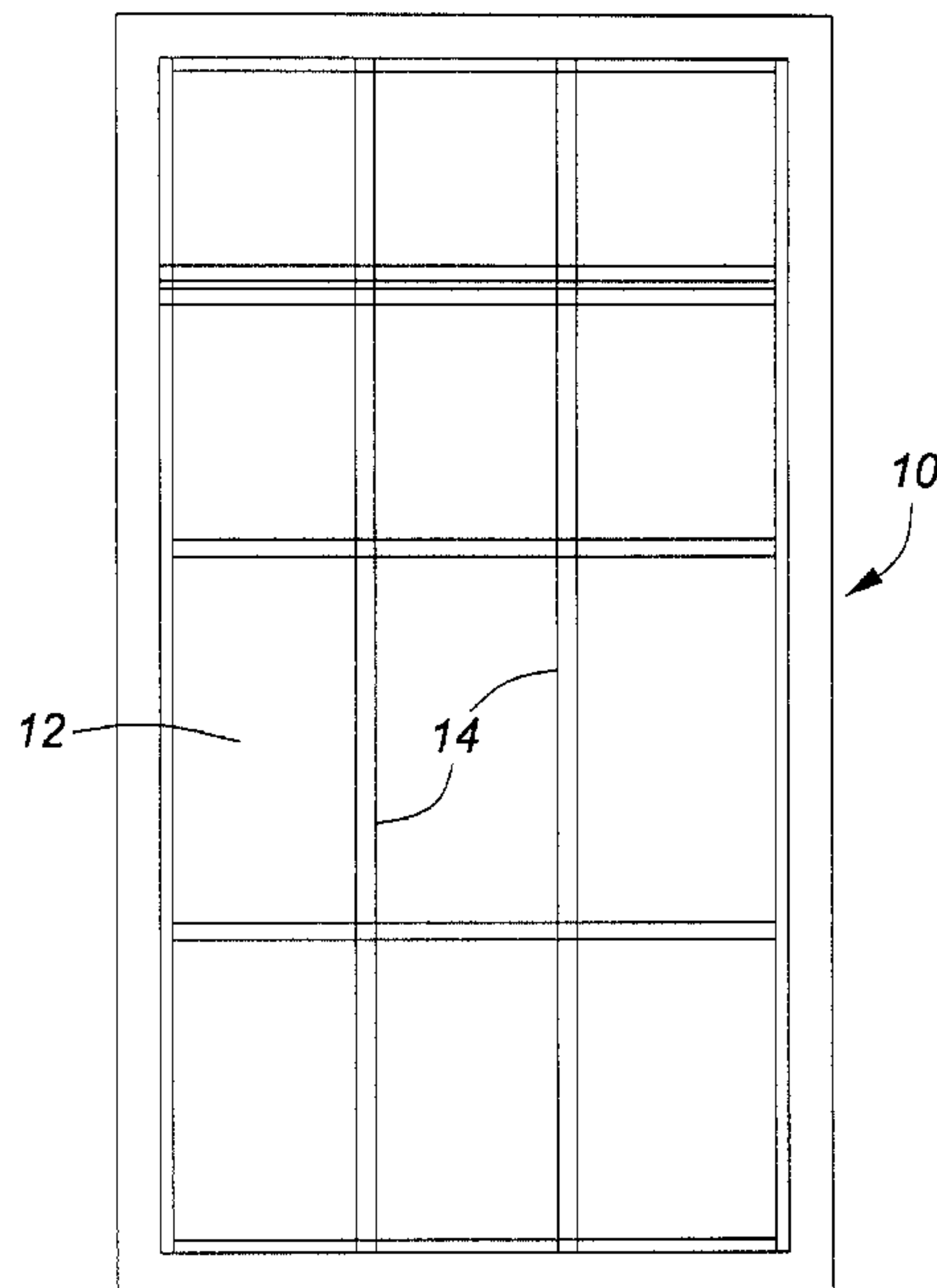

(72) CAMPBELL, NORMAN WOOD, CA
(72) COSTFORD, DAVID L., CA
(71) HERCULETE TECHNOLOGIES, L.L.P., US
(51) Int.Cl.⁶ E04C 2/06
(54) PANNEAU DE CONSTRUCTION
(54) BUILDING PANEL



(57) This specification discloses a light-weight building panel, a building system incorporating the panels and the process of making them. The process includes a cementitious material in the form of a fibre-reinforced cellular concrete which weighs approximately 26% of regular-concrete. Light-weight metal members are partially embedded in the cementitious material during the manufacturing of the panel and the members project therefrom. One embodiment has exposed "C"-shaped channel members that provide, in a wall or floor panel, studs ready in place to receive plaster board or dry-wall sheets. It also provides a recessed wall for installation of electric boxes and the like.

ABSTRACT OF THE DISCLOSURE

This specification discloses a light-weight building panel, a building system incorporating the panels and the process of making them. The process includes a cementitious material in the form of a fibre-reinforced cellular concrete which weighs
5 approximately 26% of regular concrete. Light-weight metal members are partially embedded in the cementitious material during the manufacturing of the panel and the members project therefrom. One embodiment has exposed "C"-shaped channel members that provide, in a wall or floor panel, studs ready in place to receive plaster board or dry-wall sheets. It also provides a recessed wall for installation of electric
10 boxes and the like.

BUILDING PANEL

FIELD OF THE INVENTION

This invention relates to precast building panels and in particular to a building panel formed of a light-weight cementitious material having light-weight metal channel members embedded therein.

BACKGROUND OF THE INVENTION

There has long been a need for a building panel of the precast variety that would be extremely light in weight and having a high tensile strength. One of the purposes of such a panel would be to utilize partially embedded channel members therein for the subsequent fastening of interior finishing materials such as wallboard and the like. However, in the past, the attempted use of light-weight metal channels, for example "C"-shaped channels, embedded in regular concrete has failed to achieve commercial success. The main problem with panels resulting from the previous attempts at their production has been that regular concrete would, by nature of its own weight, overcome the physical properties of light-weight metal channels embedded therein and would render them useless when viewed as an integral structural element in the panel being created. In reality, the addition of "C"-shaped channel members and a regular concrete mix actually created more problems than it solved as additional steel reinforcing and wire mesh would be required to supply the necessary structural integrity of the panel due to a weak section created by the embedding of the channel member in a thin layer of concrete. The concrete was necessarily thin, two inches

being typical, so as to create a benefit of "light-weight" which was the very reason for the creation of the panel.

There have been numerous attempts at providing a precast building panel with structural members embedded therein. Some examples may be found in European
5 Patent 0 434 869 B1. This patent discloses the anchoring of metal studs in a precast concrete building panel.

U.S. Patent 5,178,941 discloses a composite material of a weight lighter than concrete.

U.S. Patent 4,774,794 discloses the embedding of members in a foam cement
10 slab.

U.S. Patent 4,910,076 discloses a cement matrix reinforced with a fibre network.

Other patents of interest are U.S. 5,248,549; 5,473,849; 4,124,669; and 5,520,729.

15 SUMMARY OF THE INVENTION

In addressing the short comings of the prior art, some examples of which are referred to above, the present invention is the result of a need to create a viable, light-weight panel system that would succeed in the broad use of the commercial market place. One of the objectives of the present invention was to use readily obtainable
20 construction materials and methods to produce a light-weight cementitious material with a higher tensile strength than regular concrete. This was accomplished by creating a reinforced building panel with two uniquely different elements for the required strength and lightness of the product.

For a cementitious material, we use a fibre-reinforced cellular concrete
25 mixture sold under the trade name **Herculete**. This material is the result of a composition of portland cement, water, synthetic fibres and an expanding agent. A full description of this material may be found in United States Patent 5,397,516 of 14 March 1995. We have found that by using the fibre-reinforced cellular concrete, it is

possible, using the correct proportions, to achieve a concrete product which will resist the most common tensile stresses in low-rise structures. The resulting weight of the product is approximately 26% of the weight of regular concrete. This cementitious material is tough and light. Unlike ordinary concrete, it has a light-weight closed cell structure that is micro-reinforced with uniformly distributed synthetic fibres. It can be used in virtually any precast concrete application.

As is known, ordinary concrete is made with cement and aggregates, typically crushed stone used as fillers. The Herculete material eliminates the fillers, reinforces the cement with fibres and expands it with uniformly dispersed air cells. The air cells give it superb insulating properties, convenient lightness and easy usability. The material is made from commonly used time-proven building materials such as aluminum, calcium, magnesium and silica and the expanding agent is made from commonly used materials. The cementitious material is easy to mix and can be handled and molded like ordinary concrete, it can be used in place of ordinary concrete in most precast applications and the resulting products are tough, light-weight and easy to cut and shape.

The composition of the cementitious material (Herculete) is portland cement, water, synthetic fibres and the expansion agent. The plain cement is the main component and different types of cement can be used to achieve desired aesthetic and physical characteristics.

Plain water is used to hydrate the cement and prepare the slurry paste that subsequently expands to twice its initial volume.

A special blend of synthetic fibres are added to the slurry. These have been used for years to reinforce ordinary cement but the Herculete cementitious material uses ten times as much fibre as commonly used to reinforce concrete slabs. The manufacturing process results in approximately two thousand reinforcing strands per cubic inch of material. This is one of the factors which gives the material its characteristic toughness and resilience. Synthetic fibres, for example, polypropylene fibres, are inert and harmless.

The expansion agent is mixed into the water/cement slurry at high speeds. Following a short dormant period the cement slurry begins to rise, much like bread dough rises when the yeast is added. The composition of the expanding agent creates a controlled and sustainable rise in the slurry until it hardens.

5 The fibre reinforced cellular concrete used in this invention has a homogenous nature so that the thermal resistance of the material is consistent throughout. This means that the R-value of the material is constant and the R-value used in calculations for thermal transmissions are not reduced to thermal bridging as would be found in most common wall construction. Because the material is composed mainly of
10 concrete, its heat capacity allows it to store energy for later release similar to more massive wall assemblies. This translates to higher effective R-value per inch (R-2, ASHRAE 90.1) then would be determined using typical steady-state test methods.

There is an economic advantage to using this cementitious material as it allows walls to be assembled in one piece rather than having to build a wall in layers
15 as in conventional sandwich panel construction methods and in most cases allows for form stripping and panel removal a mere six hours after being poured. This translates into faster construction time and lower construction costs for the building owners.

The material may be clad with a regular or coloured face mix or alternatively may remain exposed, utilizing just about any form liner, shape/design desired, then
20 coated with an elastomeric paint which offers unlimited colour choice and control, various textures and with durability and ease of maintenance in mind.

As mentioned earlier, the present invention provides a reinforced concrete panel with two uniquely different systems for the required strength and lightness of the product. The first system is the approximately 2000 micro-fibre per cubic inch in
25 a matrix of cement and water which forms a microscopic enclosed cell structure that is capable of resisting the movements of the second element.

The second element consists of a light-weight galvanized channel that has been altered to provide slots or perforations along its web section to accommodate the passage of the liquid cementitious material in the manufacturing process then later to

provide for the passage of electrical, mechanical and/or plumbing components in the field. The two elements of the invention are weak and flexible on their own, in comparison to a regular concrete assembly, but when brought together and in combination, one element restraining the movement of the other, a very strong light-weight panel is the result. The components are economic and are ideal for mass production for use in general construction of all types.

Given the excellent thermal characteristics of Herculete and the fact that it will take about any shape, provides an opportunity to create a panel for a residential wall system (as well as commercial and industrial wall systems) using a formliner that by its own design and texture provides for the exterior finish of a structure. A thermal break between the "outside conditions" and the embedded "C" channel and the thickness of the Herculete dictates the thermal resistance as required by specification or code.

In a two story residential application the vertical wall panel (plain exterior finish by example) is simply rotated to the horizontal plane and becomes an ideal lintel or floor system. This system provides for a squeak proof, sound deadening, flooring system that is attached to both the lower exterior and upper exterior wall by a unique system that has been created for the specific purpose. Through testing, this floor system has been proven to carry the necessary residential loads over typical spans with acceptable deflections.

A channel system of varying lengths is used and anchored in the top of the lower exterior walls at varying stages along that surface. They are unique, in that by design, the channel will accept a "T" bolt that when rotated 90 degrees will restrain that bolt from the vertical forces but allow (until tightened) movement along its length for proper alignment with the other (floor and upper exterior wall) components that, by design, are held together to meet the most stringent codes with one effort. The uniqueness of this device is that when molded into the Herculete and "C" channel panel during the manufacturing process it can be used as a lifting point for the efficient handling of the panel assembly in the manufacturing plant, during

transportation, and as part of the erection on site process. Further, by design, this connection system allows for the safety of the lower exterior walls and the floor system to be connected (irrespective of the upper wall placement) to produce a ridged, safe system.

5 According to one broad aspect the invention relates to a building panel for use in a wall structure, said panel comprising a body of hardenable cementitious material with a plurality of light-weight metal members partially embedded therein, said cementitious material comprising a fibre-reinforced cellular concrete having a weight substantially less than that of regular concrete, said light-weight metal members
10 projecting from said body of cementitious material to provide studs ready for reception of finishing wall board or the like and to provide a recessed wall to facilitate the installation of electrical systems and the like.

 According to a further broad aspect, the invention relates to a precast, light-weight building panel comprising, in combination, a body of cementitious material consisting of portland cement, water, synthetic fibres in a density of approximately
15 two thousand fibrous strands per cubic inch of cementitious material and an expanding agent, and a plurality of light-weight galvanized metal studs of generally "C"-shape laid parallel to one another and partially embedded in said cementitious material so that they project outwardly of the material after it has set, said studs
20 having slots therein to allow passage therethrough of selected building services.

DESCRIPTION OF THE DRAWINGS

The invention is illustrated by way of example in the accompanying drawings in which:

FIGURE 1 is a plan view of a building panel according to the invention;
25 FIGURE 2 is a side view of the panel in Figure 1;
 FIGURE 3 is a sectional view of the panel in Figure 1;
 FIGURE 4 is a wall section of a building structure utilizing the present invention;

FIGURE 5 is a fragmentary view in cross-section as shown at location "5" in Figure 4;

FIGURE 6 is a view similar to Figure 4;

FIGURE 7 is a plan view of a panel reinforcing grid and the weld points
5 therefore;

FIGURE 8 is a detail of vertical joints between panels;

FIGURE 9 is a sectional view of a permanent forming arrangement;

FIGURE 10 is an elevation view of a junction between an interior wall and
10 floor;

FIGURE 11 is a sectional view of an alternate flooring system;

FIGURE 12 is a junction detail of an exterior wall with a floor panel;

FIGURE 13 illustrates a joint at an exterior wall and a footing;

FIGURE 14 is a schematic elevation view of a residential structure;

FIGURE 15 illustrates a wall/roof connection;

15 FIGURE 16 illustrates a residential wall in section;

FIGURE 17 is another residential wall in section but of an upper level;

FIGURE 18 is a cross-sectional view of a residential wall/floor panel
connection;

FIGURE 19 is a perspective view thereof;

20 FIGURE 20 is a graph showing the expansion process of the cementitious
material;

FIGURE 21 is a partial elevation view of a sound attenuation walls; and

FIGURES 22 and 23 are plan and sectional views thereof.

DESCRIPTION OF THE PREFERRED EMBODIMENT

25 Figures 1-3 illustrate a building panel 10 according to the invention for use in a wall structure of a dwelling, commercial building or the like. The panel 10 has a body 12 of the cementitious material Herculete in accordance with the invention and a plurality of light-weight metal studs 14 are embedded into the cementitious material

during the processing steps and those members 14 have an exposed flange 16 which, collectively, are ready for reception of finishing wall board or the like. In the example shown in Figure 2, the panel has an 8 inch depth of cementitious Herculete and a 2 ½ inch face mix 18.

5 Figure 4 is a wall section of the building panel 10, a twist and lock plate 20 being used in an embedded anchor socket 22 for the connection between a panel 10 and a beam 24.

 Figure 5 shows a section through the line 5-5 of Figure 4 and illustrates the drywall 26 secured to the projected portion of stud 14.

10 Figure 6 shows the relationship between an upper wall panel 28, a beam 30 and roof panels 32.

 Figure 7 shows a panel reinforcing grid of metal studs 14 which are equally spaced at 16 inch centres across the panel. Anchors 34 are embedded 6 inches into the cementitious material 12. Studs 14 are suitably secured to upper and lower tracks
15 36, 38 respectively.

 Figure 8 provides a detail of a vertical joint between two panels 10a and 10b. Panel 10a has a channel 40 along one of its marginal edges and that channel receives a tongue 42 on the marginal side edge of the adjacent panel 10b. The joint is roped and caulked as indicated at 44 on the outside of the joint.

20 Figure 9 shows a permanent forming arrangement where precast concrete joists 46 have Herculete panels 48 extending between pairs of the joists 46. The joists 46 are placed in position and the Herculete light-weight precast panels 48 are placed in position therebetween the concrete joists and a normal weight structural, reinforced concrete topping 50 is installed on the upper surface of the joist 46 and Herculete 48.
25 In this manner, the Herculete "forming" remains in position and provides a concrete appearance.

 Figure 10 shows a junction between an interior wall panel 10 connected to a Herculete floor panel 52. This connection is made by way of the welding together of two joining plates, one of which 54 is embedded in the Herculete floor panel 52 and

the other member 56 being anchored in the upper end of the wall panel 10.

Temporary access pockets 58 are provided for welding of the facing plates 60a and 60b of the members 54 and 56 and these access pockets are subsequently filled with plaster following inspection.

5 Figure 11 shows an alternate flooring system where an upper floor is formed by a Herculete panel 62 and the embedded metal studs 64 have projecting portions 66 to which drywall ceiling 68 is secured. The projected portions 66 creates a space between the drywall ceiling and the lower surface of panel 62 through which conduits and the like may be run.

10 Figure 12 shows a connection or junction between an exterior wall 70 and a floor panel 72. Weld plates 74, 76, 78 and 80 are embedded in their respective locations to provide welding sites such as 82 and 84.

A joint between an exterior wall 86 and a footing 88 is shown in Figure 13. Again, weld plates are embedded in the exterior wall at 90 and 92 for welding to
15 adjacent, embedded weld plates 94, 96 in the footing.

Figure 14 is a schematic of a residence which comprises a plurality of Herculete panels 10.

Figure 15 shows a wall/roof connection where the wall panel 100 is connected to a steel uplift strap 102 by way of a unit strut 104 embedded in the upper end of
20 panel 100. An alignment and locking plate 106 is located between the joints in the panels.

Figure 16 is a cross-section through a residential wall showing the panel 110 having the exposed metal studs 114 embedded in the Herculete cementitious material 112. The wall 110 is channelled to received a floor panel 116 which also has exposed
25 metal studs 114 embedded in the cementitious material of the floor panel.

The wall panel 110 is located on a footing 118 provided with anchor bolts 120 to which the metal stud members may be fastened. Such an arrangement lends itself to very quick erection and the studs 114 are ready and placed to receive drywall.

Figure 17 is an upper extension of the Figure 16 illustration and shows the uplift strap 102 previously illustrated in Figure 15 used here to locate the upper part of wall panel 110 to its proper location with a wooden truss 122. The lower end of the strap 102 is received in the anchor box 124 embedded in the upper end of wall panel
5 110.

Figure 18 is a cross-section through a residential wall/floor panel, the upper wall 111 being joined to the lower wall 110 through the combination of an anchor sleeve 126 embedded in the upper end of the lower wall 110 which receives one end of an anchor bolt 128 having a twist-and-lock head 130 thereon, that head being
10 received in the anchor sleeve 126. The anchor bolt 128 passes through a slot 132 provided in the floor panel, as shown in Figure 19, and a pocket 134 is provided in the floor panel to receive a spreader plate 136.

At the upper end of the connection, a metal angle 138 is embedded in the upper wall panel 111 and the overall connection is secured in place by a nut 140.

15 Figures 21, 22 and 23 illustrate a highway sound attenuation barrier made from panels in accordance with the material disclosed by the present invention. As shown in Figure 21, a plurality of panels 150, 152 and 154 are located on top of one another with their marginal edges engaging one another. The end portions of each of the panels are formed to slideably engage a steel post 156 and a cap portion 158
20 engages the upper end of the post and is large enough in area to also cover small face panels 160 that overlie the connections between the aligned ends of the panels and the post itself. This provides for a light-weight, affective sound attenuation wall.

Figure 20 is a graph showing the expansion process of the cementitious material Herculete used in the present invention. Due to the composition of the
25 cementitious material, its heat capacity allows it to store energy for subsequent release. This translates to an insulation value of R2 per inch whereas normal concrete has an insulation value of R.017 per inch. This insulation characteristic makes the substance ideally suited as an energy efficient material for residential and commercial construction.

The panels utilizing the cementitious material of the invention permits removal of the finished product from its form work within a six hour period whereas normal concrete requires twenty-four hours. This greatly enhances productivity.

5 It will be appreciated that form liners can be used in the process to provide a variety of finishes such as stucco, brick, fluted block, etc. Colours can also be added to the mix. A number of products can be made utilizing the cementitious material. These include residential floor systems to replace existing wood joist and plywood sheeting and by means of which the flooring is fire resistive and provides sound attenuation.

10 Residential and commercial exterior wall systems to replace the time-consuming, conventionally layered concrete brick or stucco exterior backed by studs, insulation and vapour barrier.

15 Commercial roof systems; precast sandwich panels, spandrel panels, modular classrooms, utility buildings, highway environmental sound attenuation barriers; and common walls and fire walls for residential and commercial buildings.

While the invention has been described in connection with a specific embodiment thereof and in a specific use, various modifications thereof will occur to those skilled in the art without departing from the spirit and scope of the invention as set forth in the appended claims.

20 The terms and expressions which have been employed in this specification are used as terms of description and not of limitations, and there is no intention in the use of such terms and expressions to exclude any equivalents of the features shown and described or portions thereof, but it is recognized that various modifications are possible within the scope of the invention claims.

The embodiments of the invention in which an exclusive property or privilege is claimed are defined as follows:

- 5 1. A building panel for use in a wall structure, said panel comprising a body of hardenable cementitious material with a plurality of light-weight metal members partially embedded therein, said cementitious material comprising a fibre-reinforced cellular concrete having a weight substantially less than that of regular concrete, said light-weight metal members projecting from said body of cementitious material to provide studs ready for reception of finishing wall board or the like and to provide a recessed wall to facilitate the installation of electrical systems and the like.
- 10 2. A building panel according to claim 1 wherein said cementitious material consists of approximately two thousand micro fibres per cubic inch in a matrix of cement, water and an expanding agent to form a microscopic enclosed cell structure.
- 15 3. A building panel according to claim 2 wherein said micro fibres are polypropylene.
4. A building panel according to any one of claims 1, 2 or 3 wherein said light-weight metal members are "C"-shaped channels of galvanized material.
- 20 5. A building panel according to any one of the preceding claims 1-4 wherein said body of hardenable cementitious material provides a panel having an outer surface for said wall structure, said light-weight metal members comprising a plurality of parallel studs spaced from one another and partially embedded in said cementitious material, and openings in metal members for the passage therethrough of service cables and the like.

6. A precast, light-weight building panel comprising, in combination, a body of cementitious material consisting of portland cement, water, synthetic fibres in a density of approximately two thousand fibrous strands per cubic inch of cementitious material and an expanding agent, and a plurality of light-weight
5 galvanized metal studs of generally "C"-shape laid parallel to one another and partially embedded in said cementitious material so that they project outwardly of the material after it has set, said studs having slots therein to allow passage therethrough of selected building services.

1/15

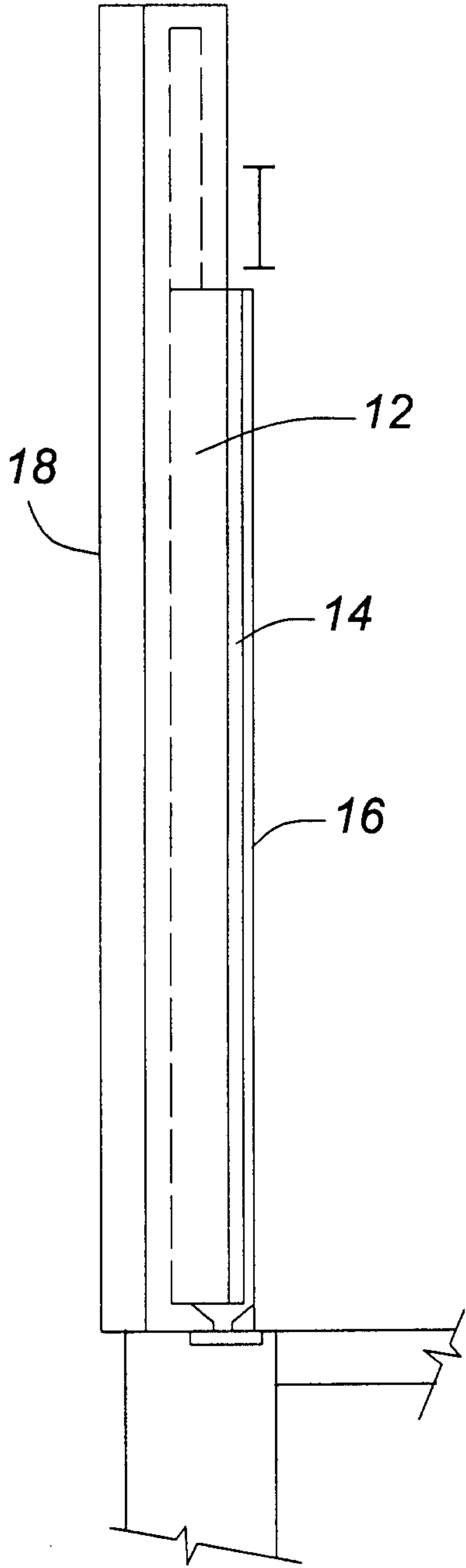

FIG. 2

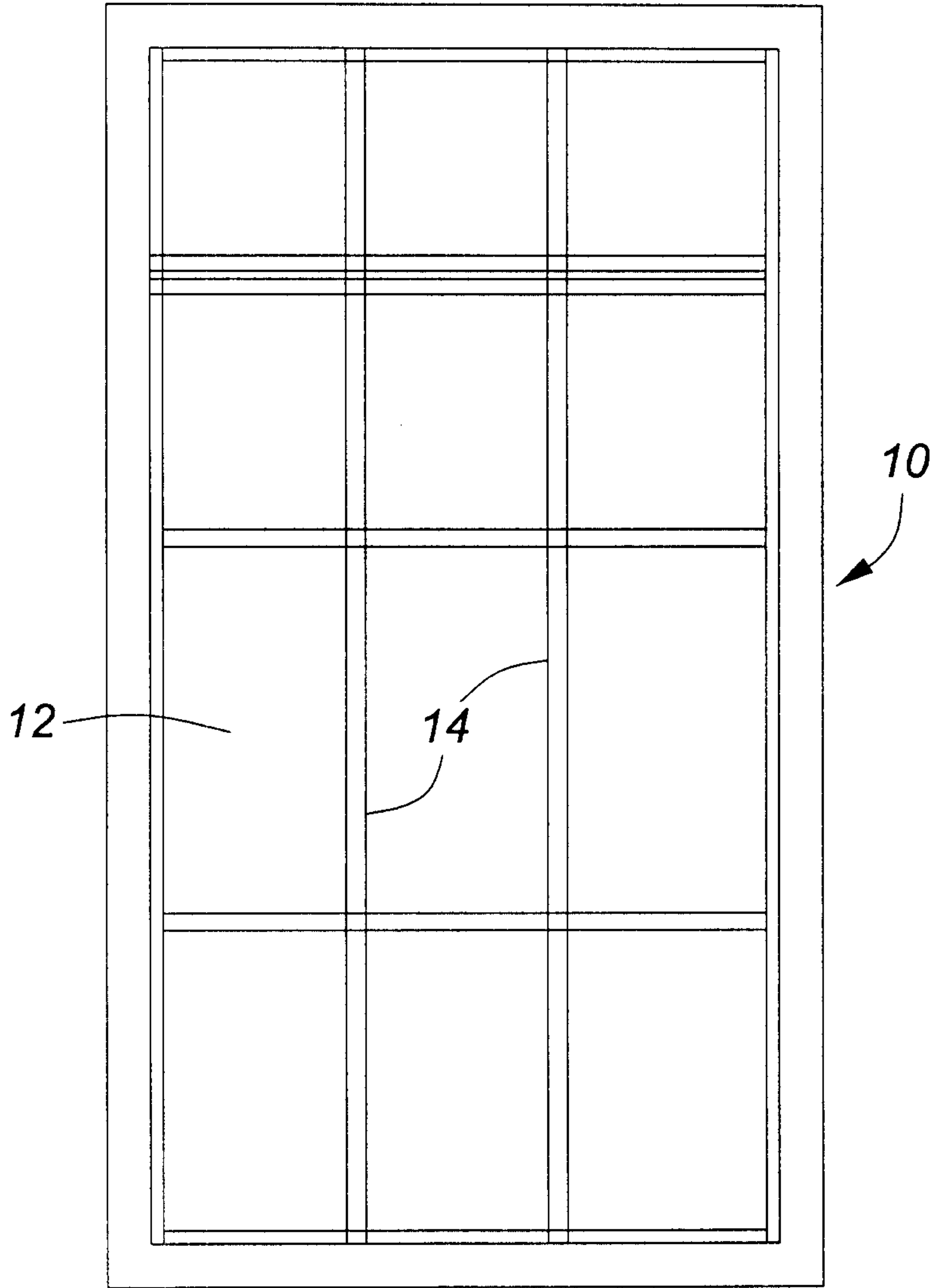

FIG. 1

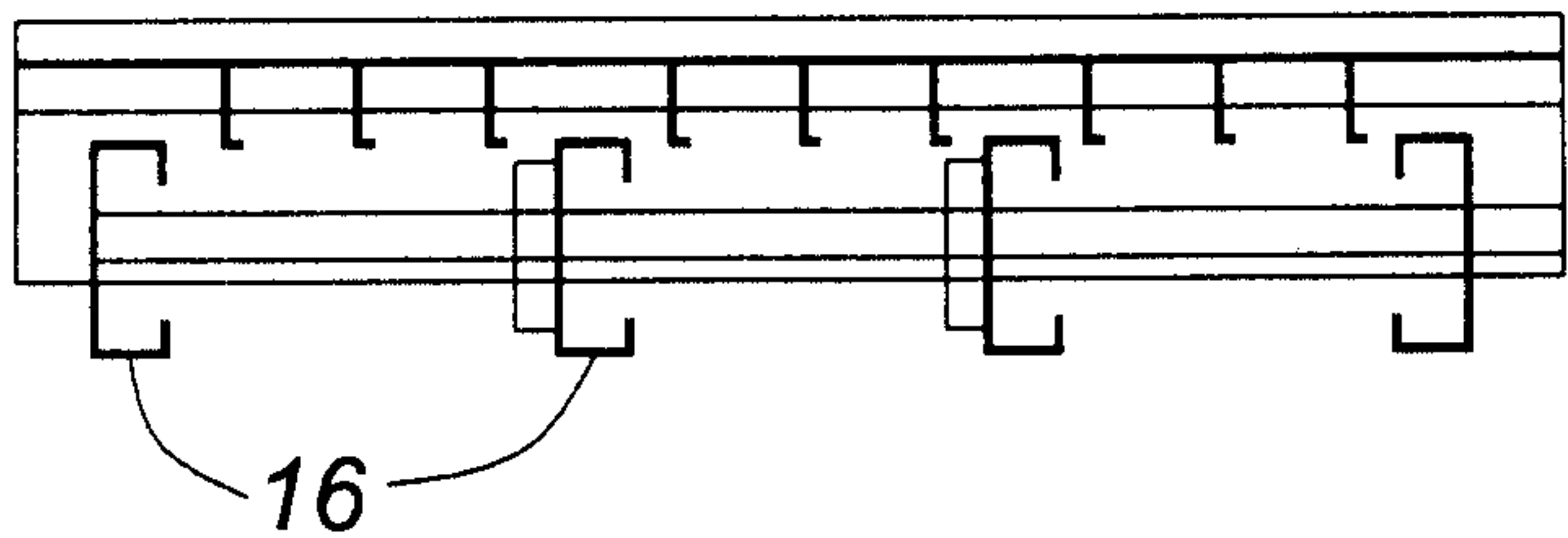

FIG. 3

2/15

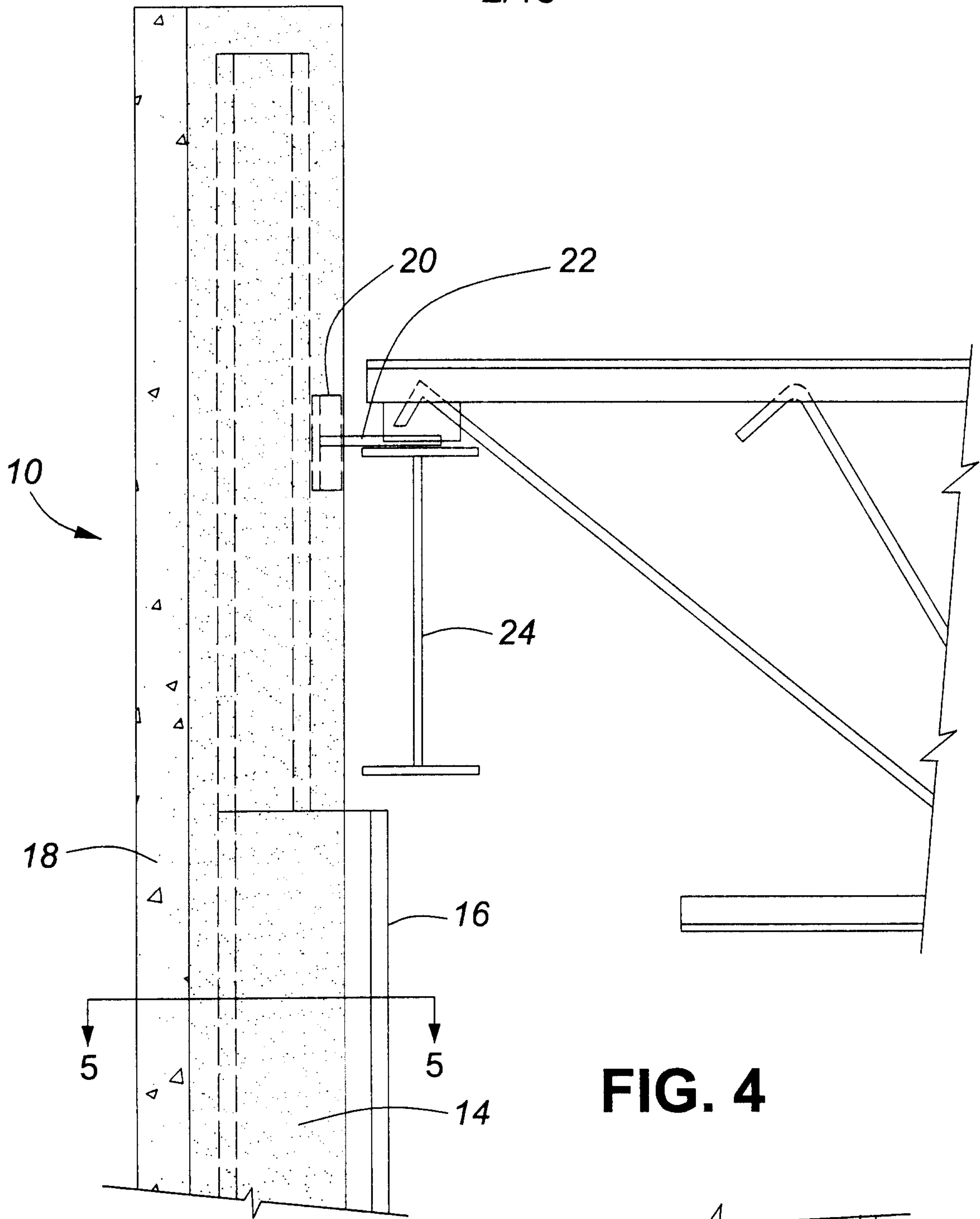
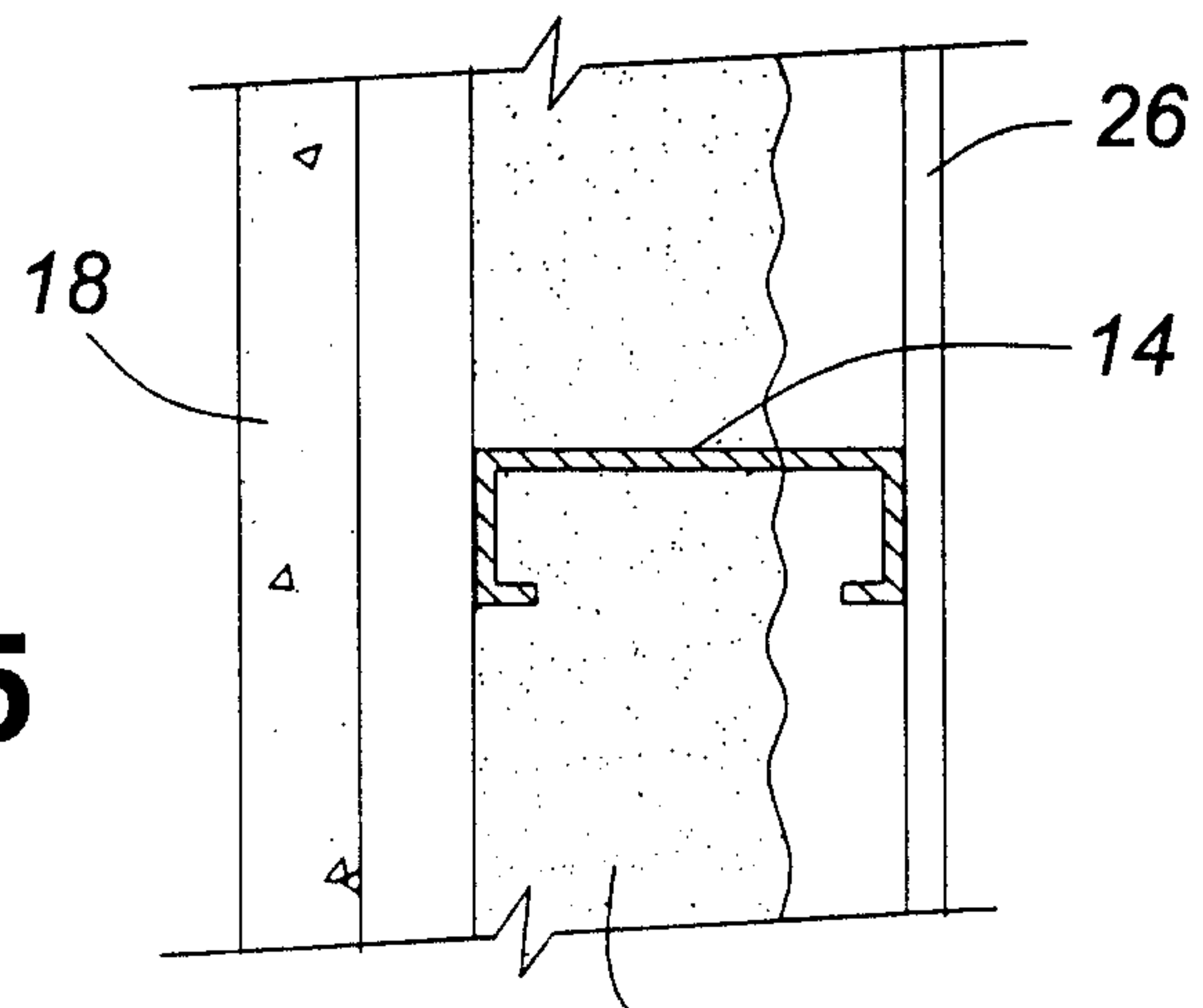

FIG. 4

FIG. 5



3/15

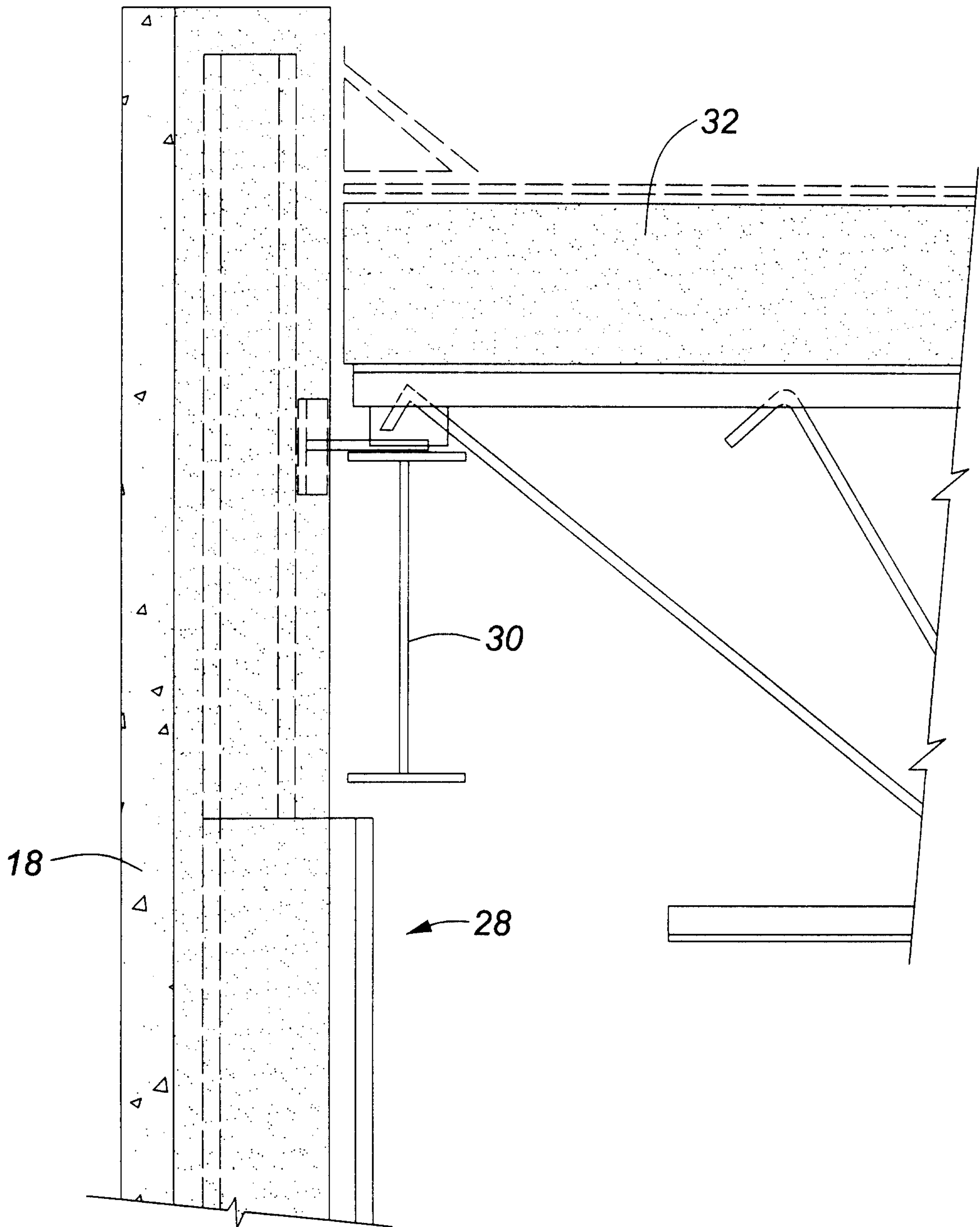

FIG. 6

4/15

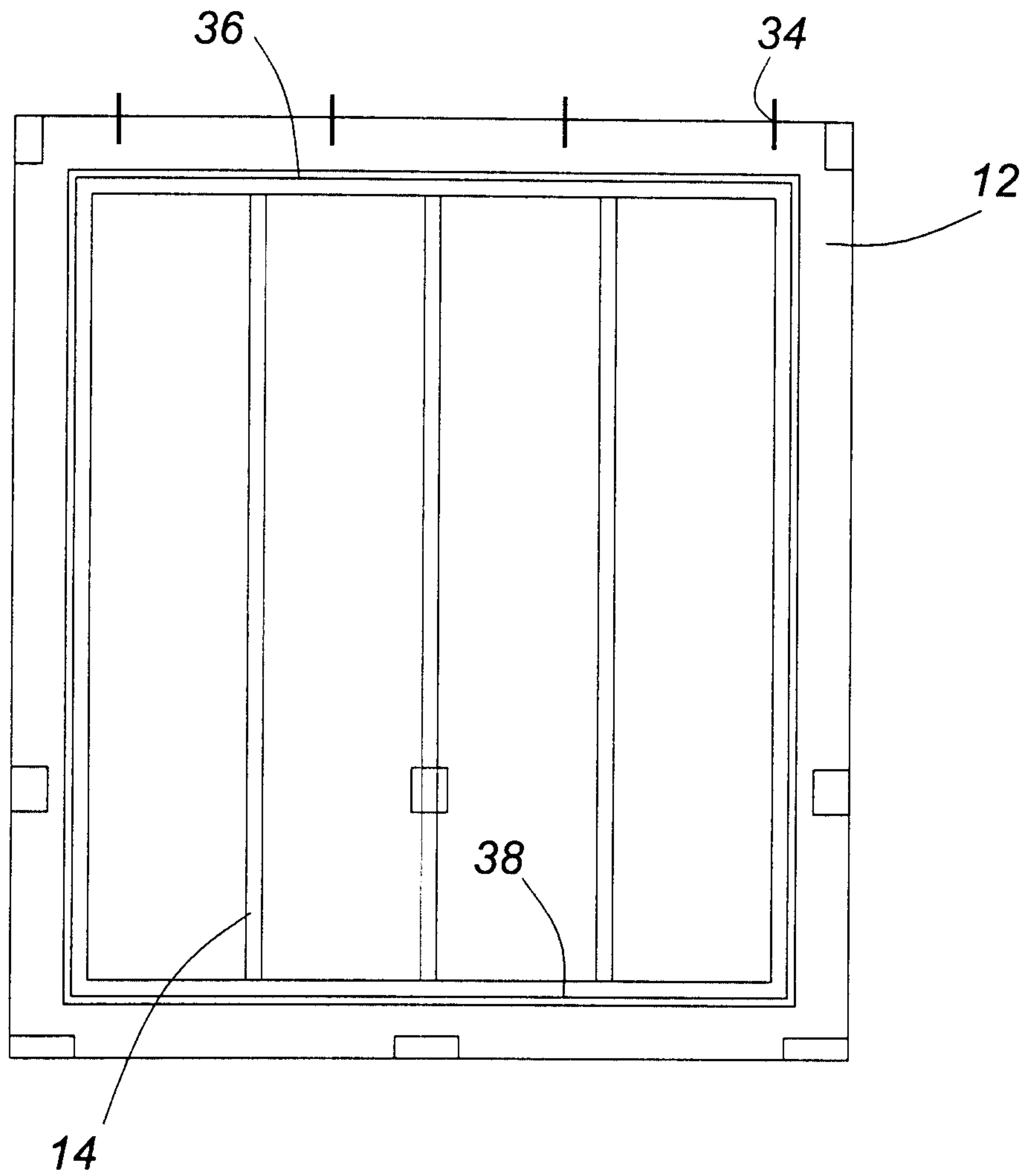

FIG. 7

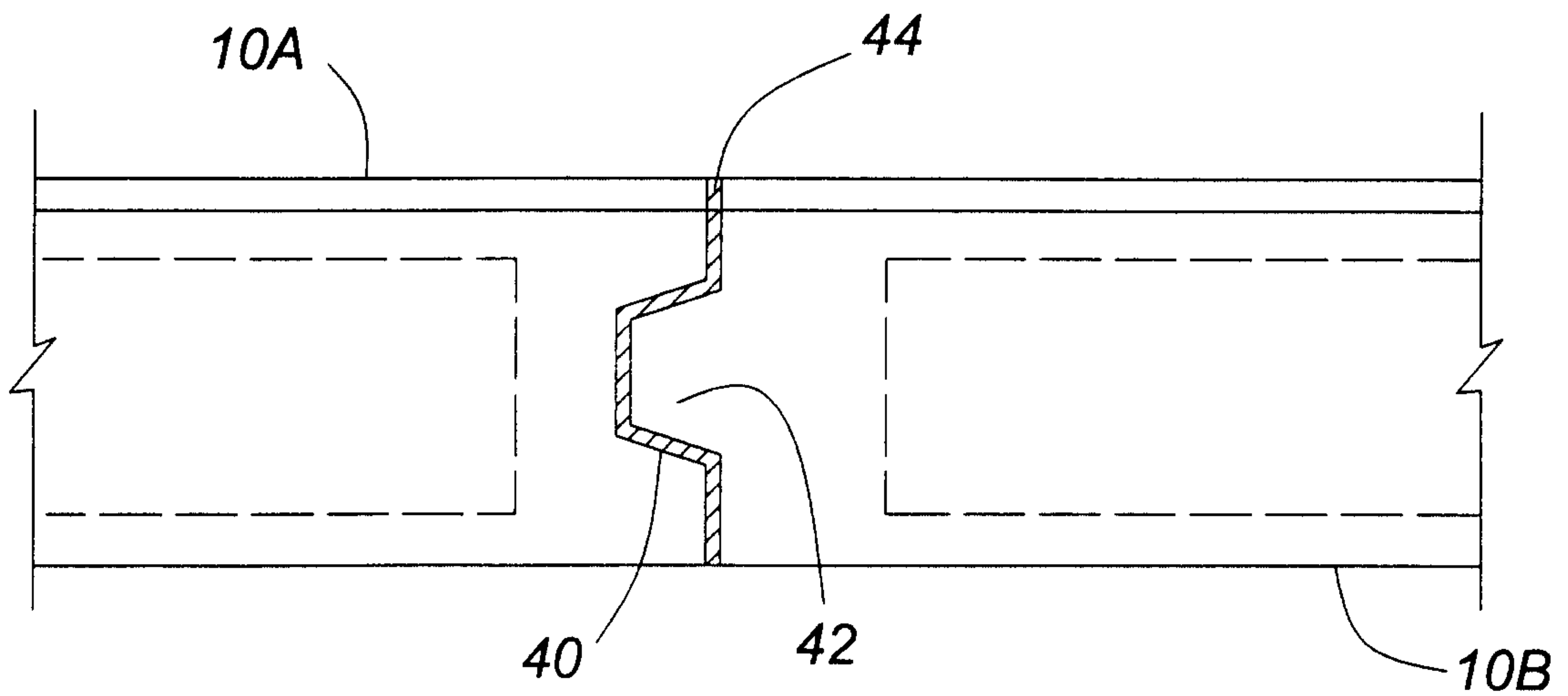

FIG. 8

5/15

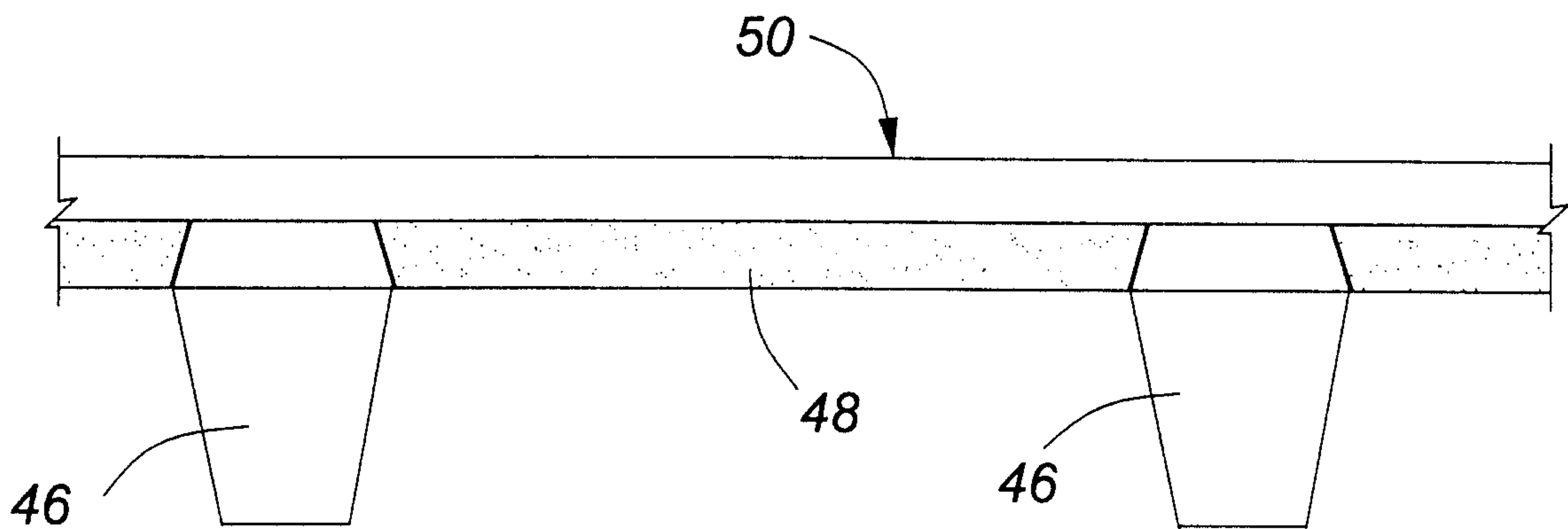

FIG. 9

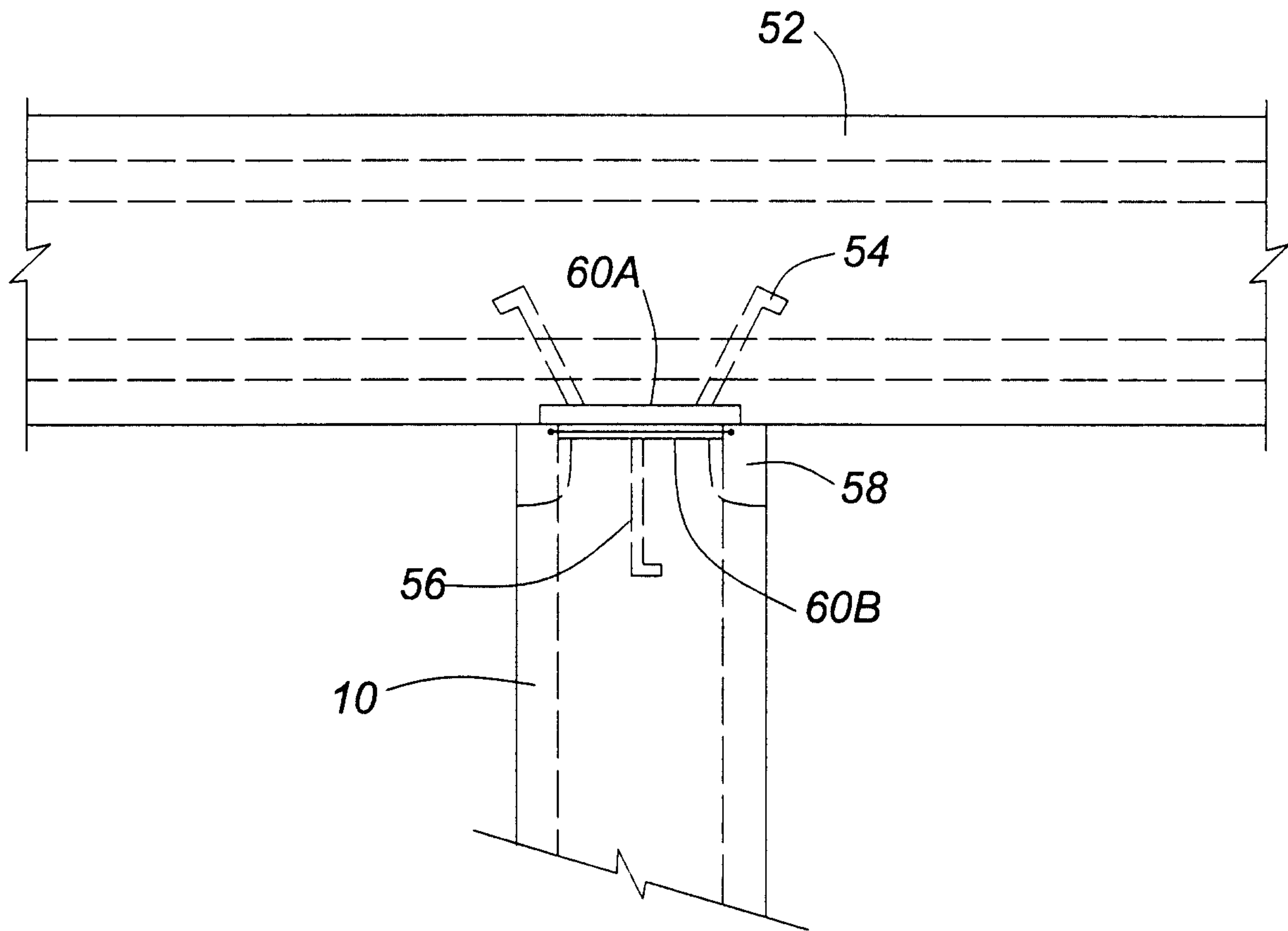

FIG. 10

6/15

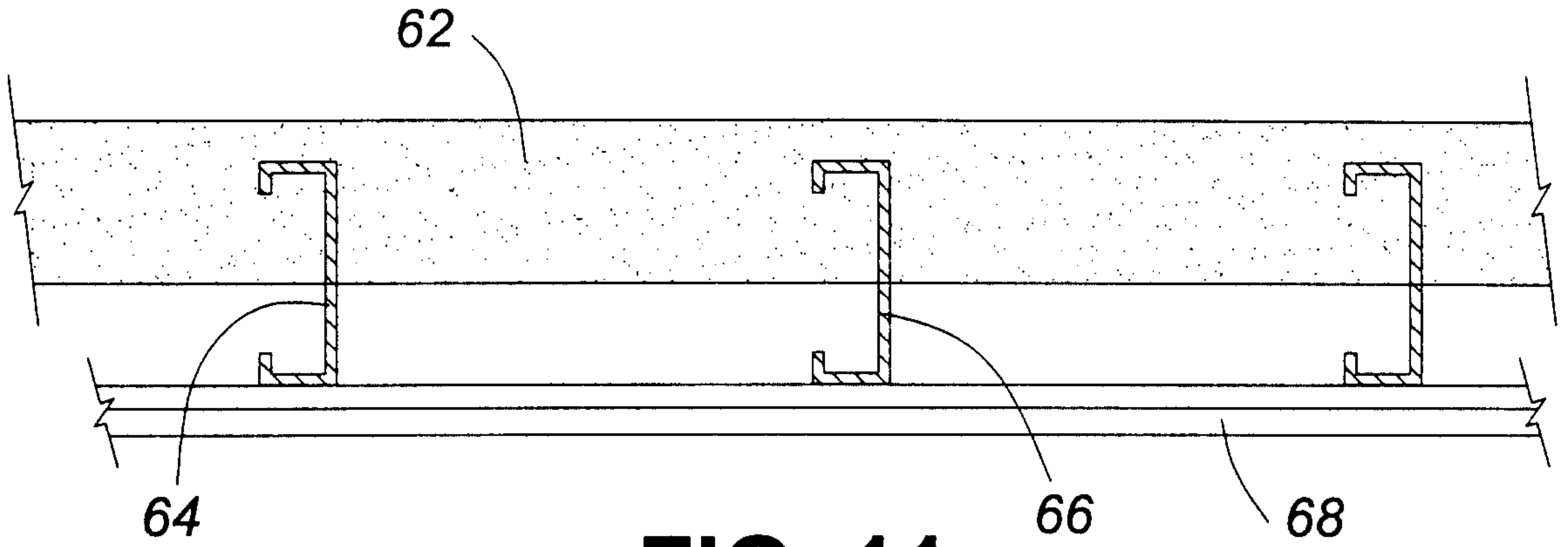

FIG. 11

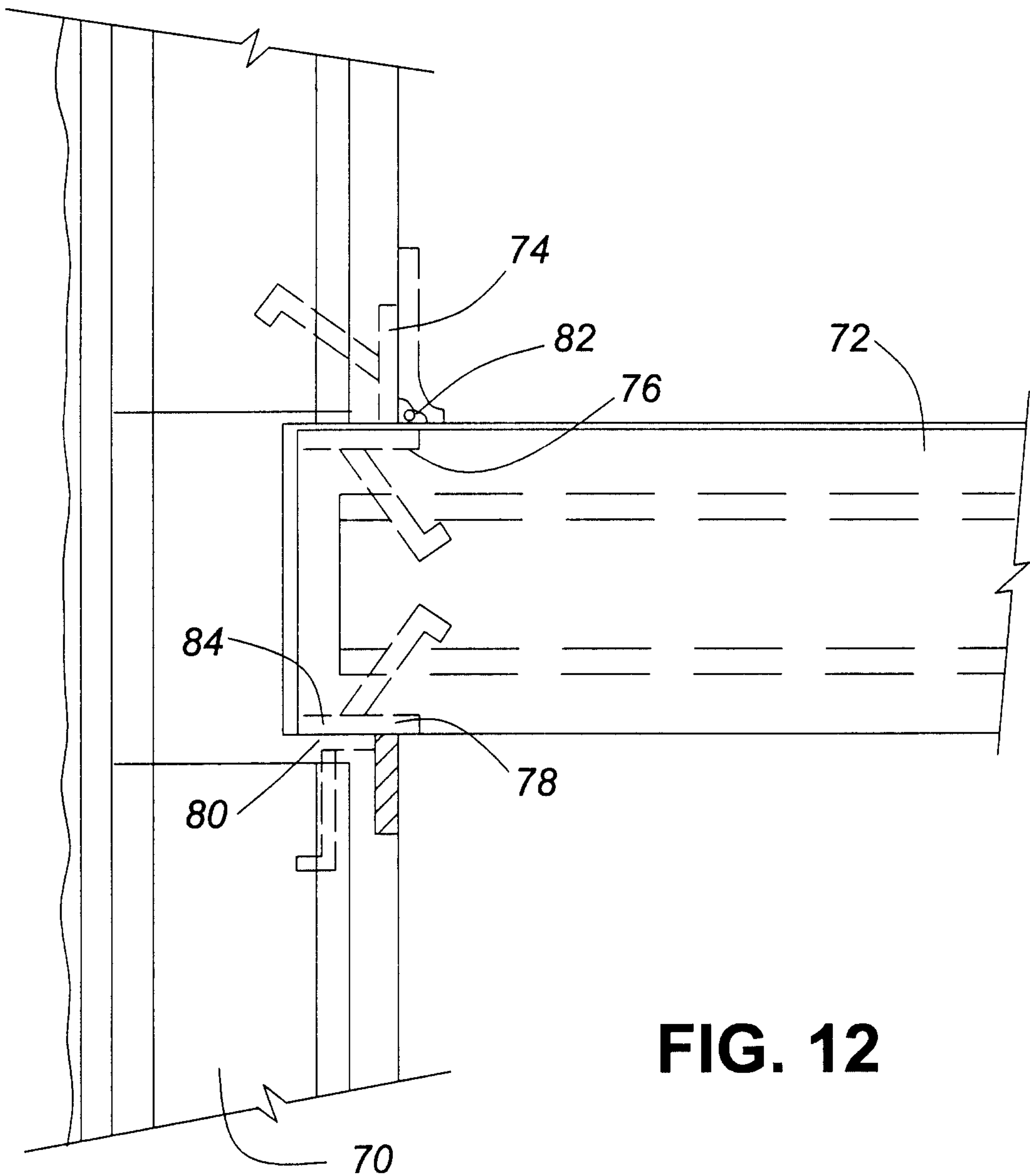

FIG. 12

7/15

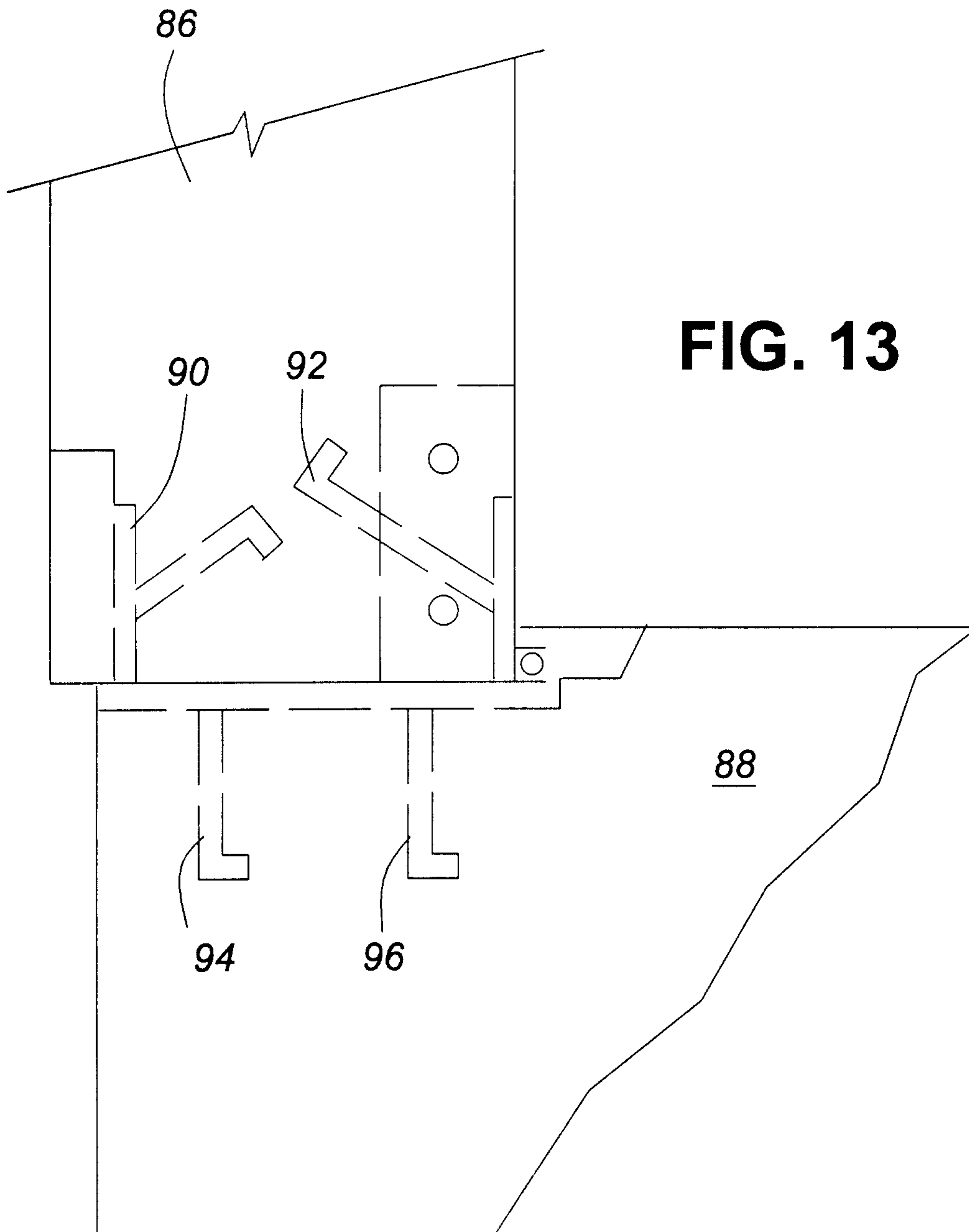

FIG. 13

8/15

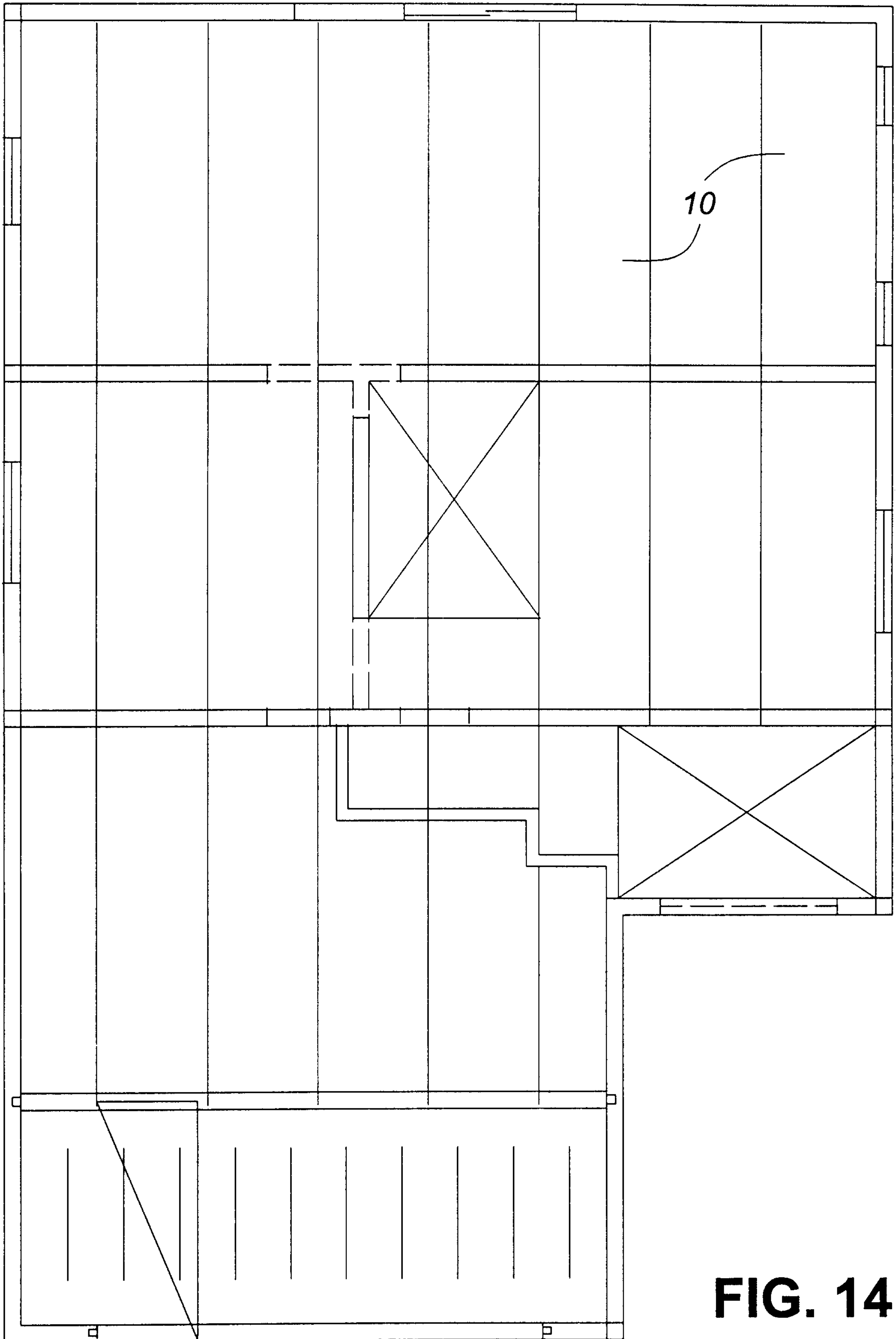

FIG. 14

9/15

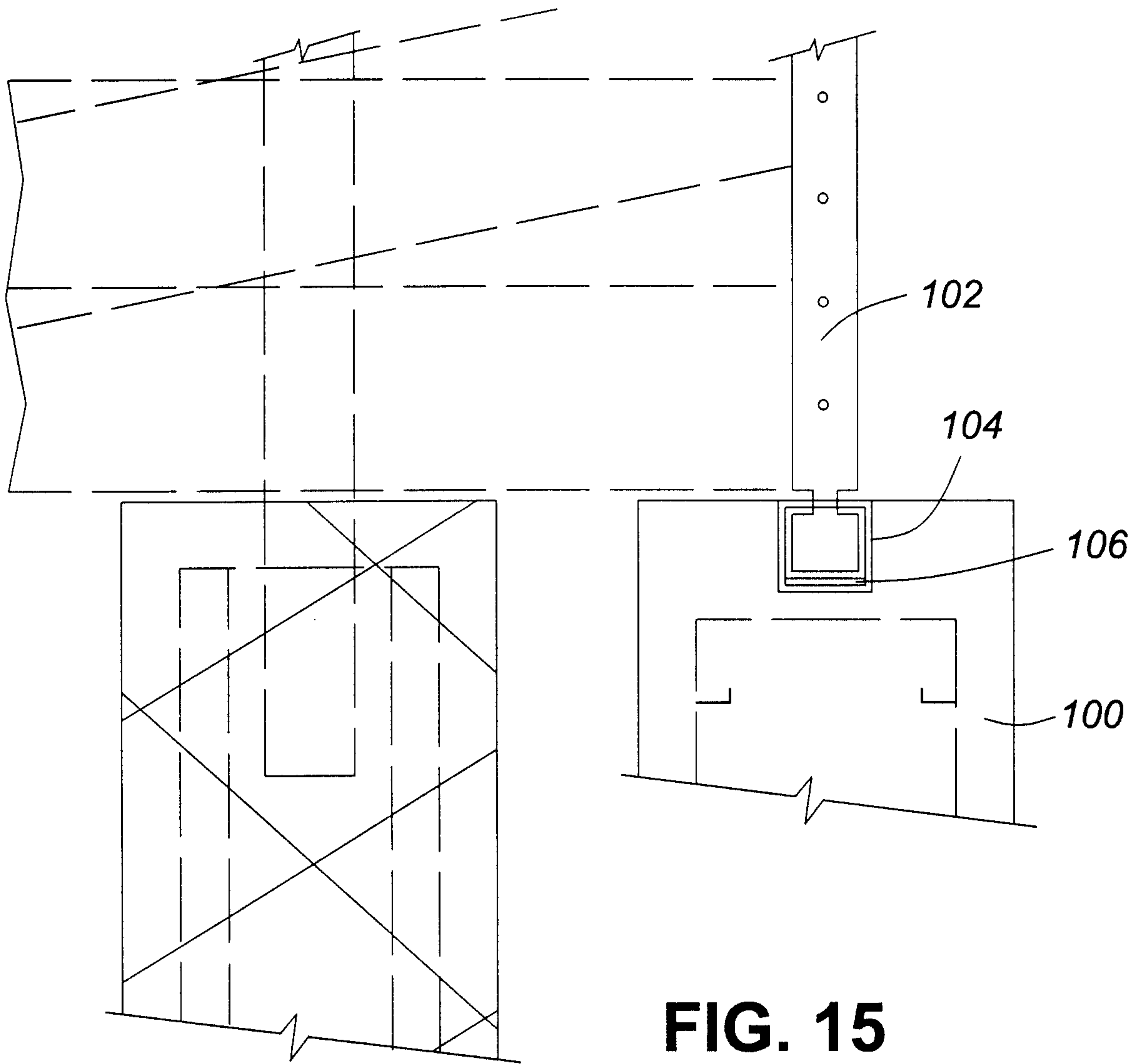

FIG. 15

10/15

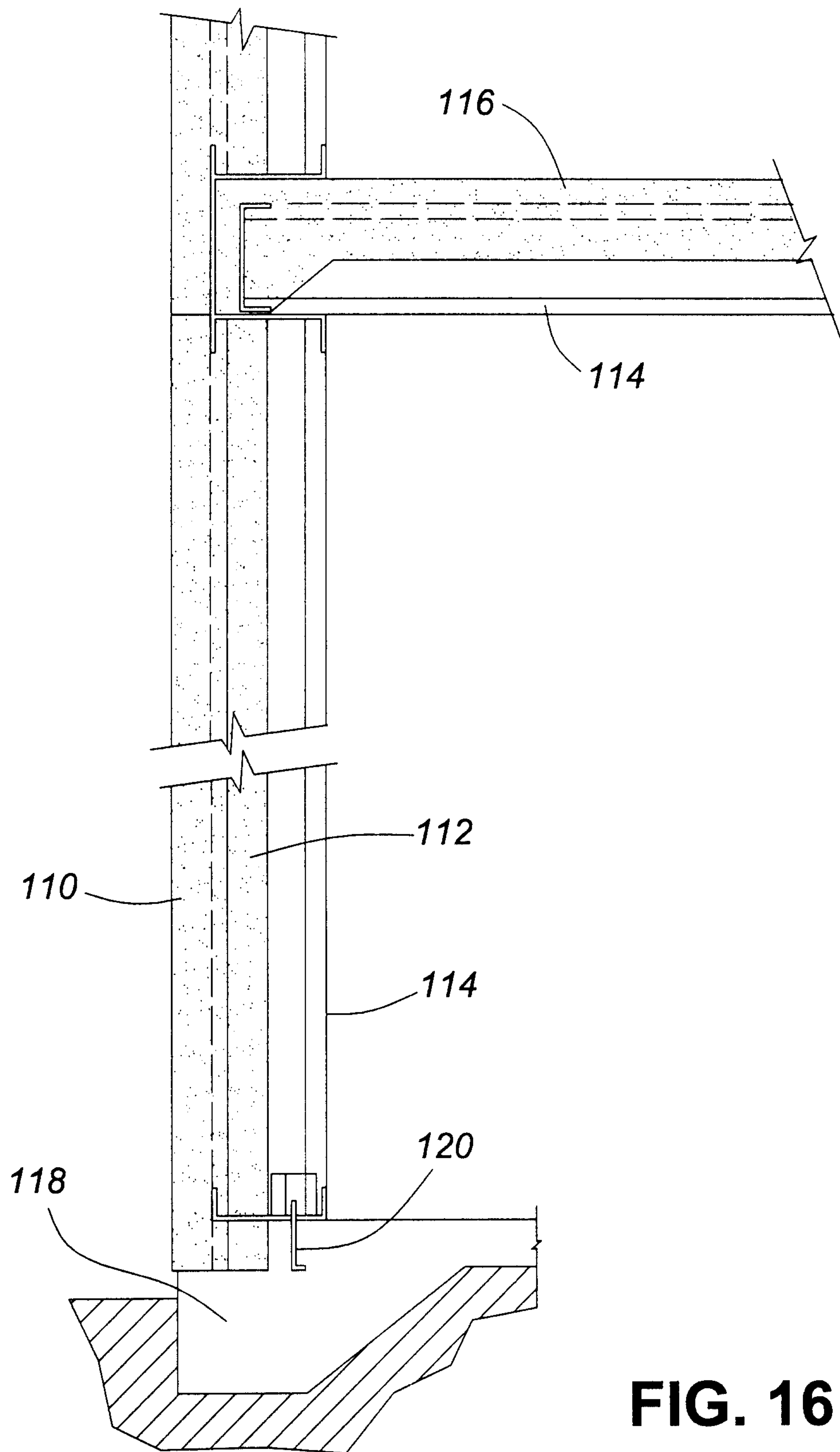

FIG. 16

11/15

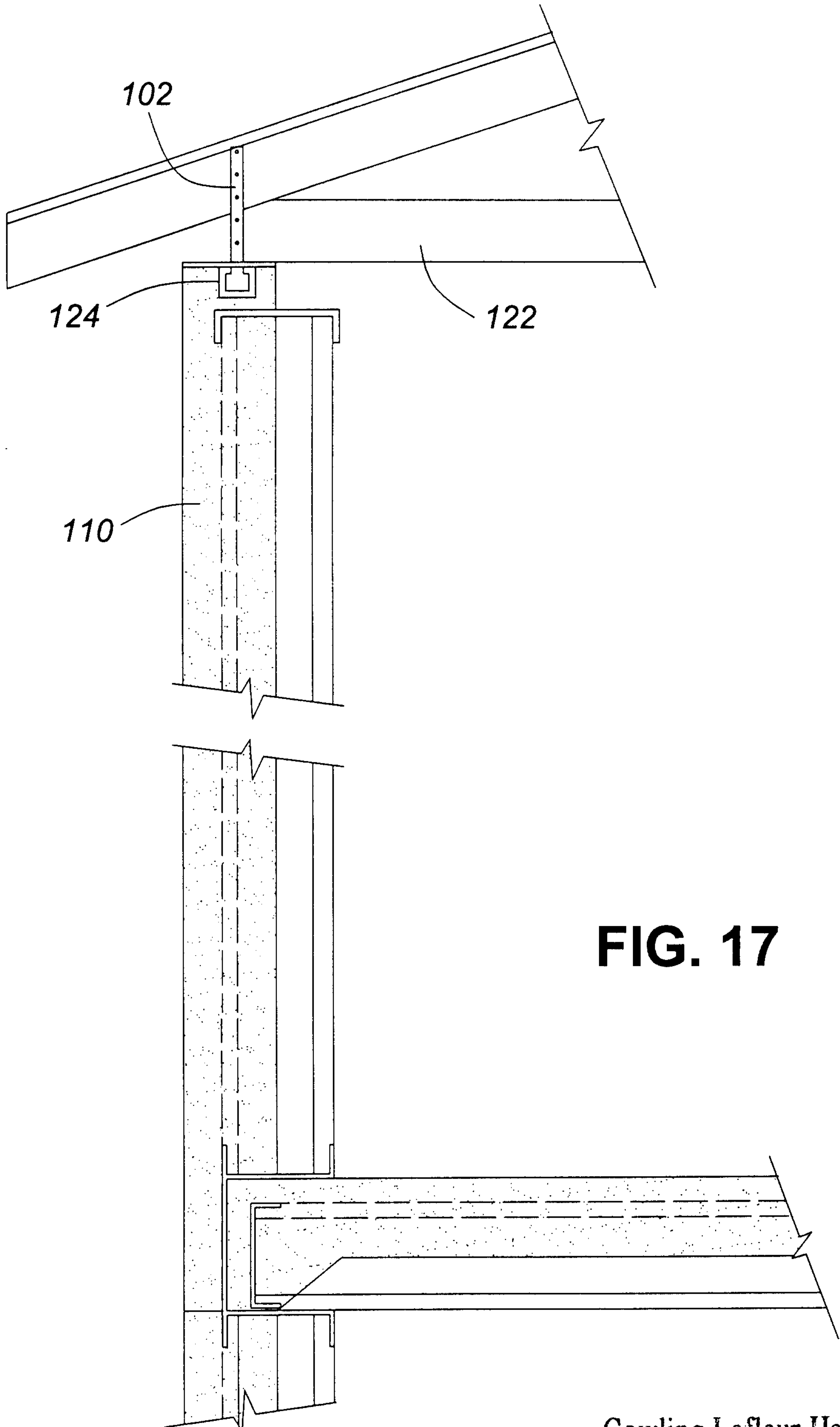

FIG. 17

12/15

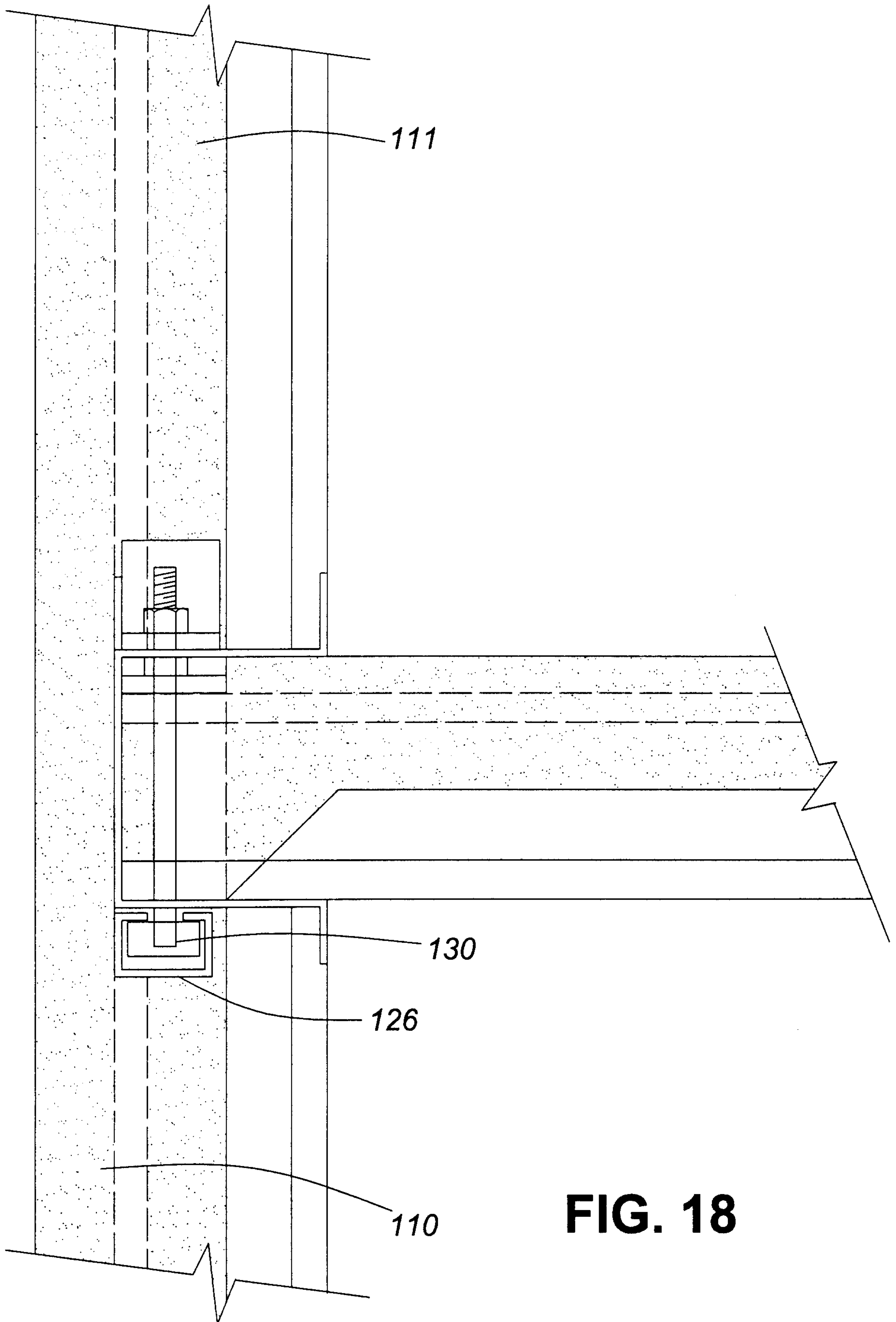
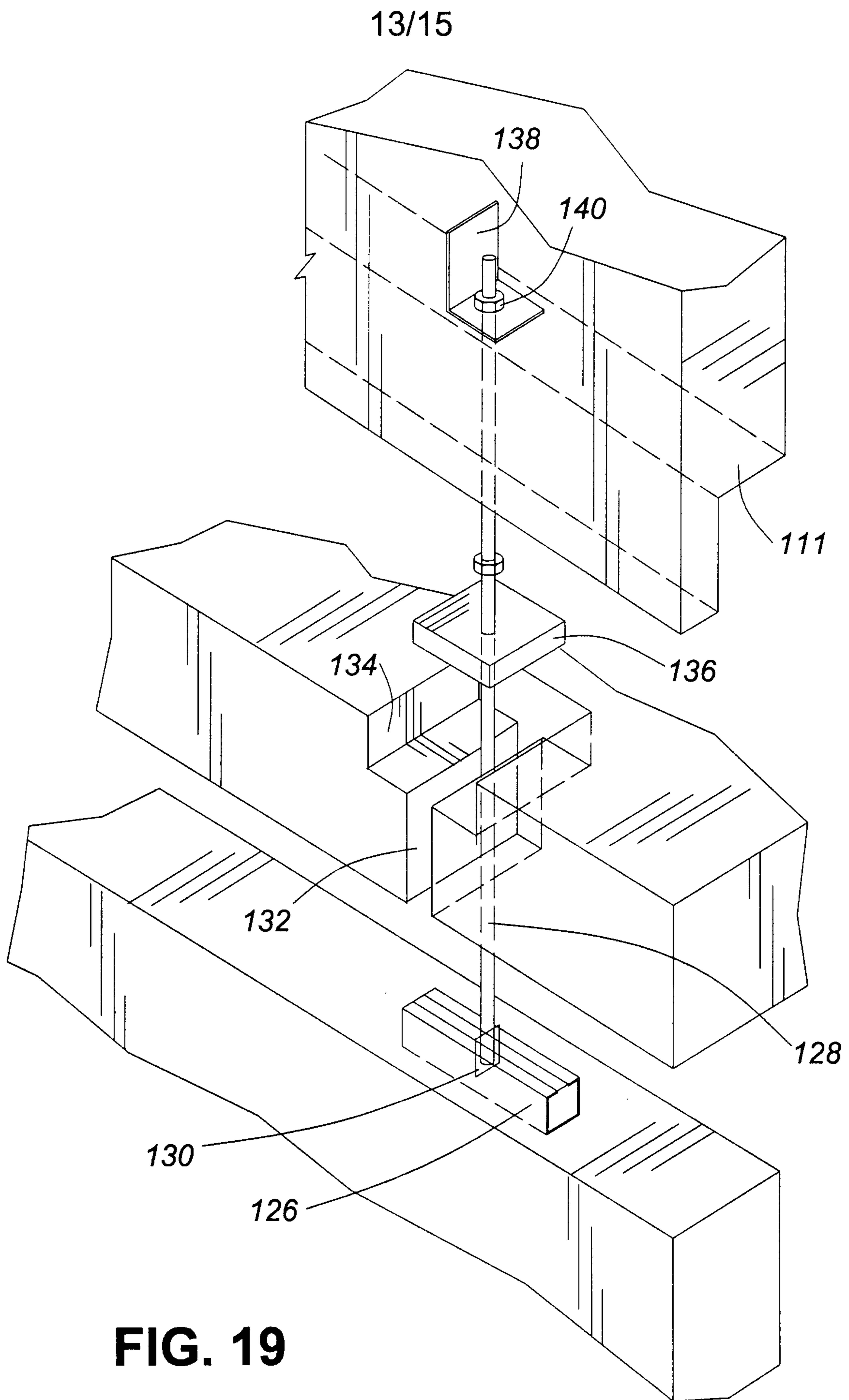

FIG. 18



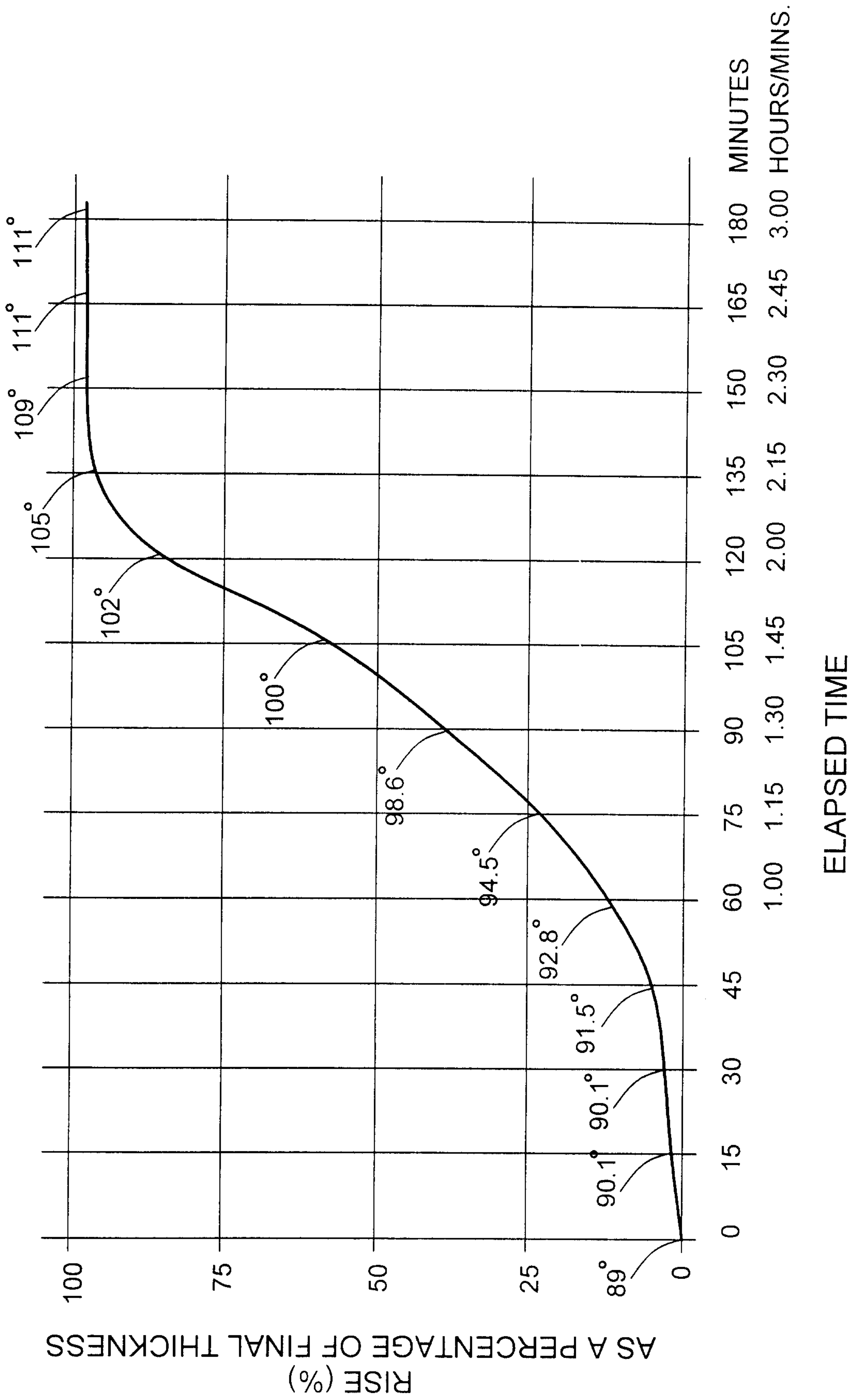

FIG. 20

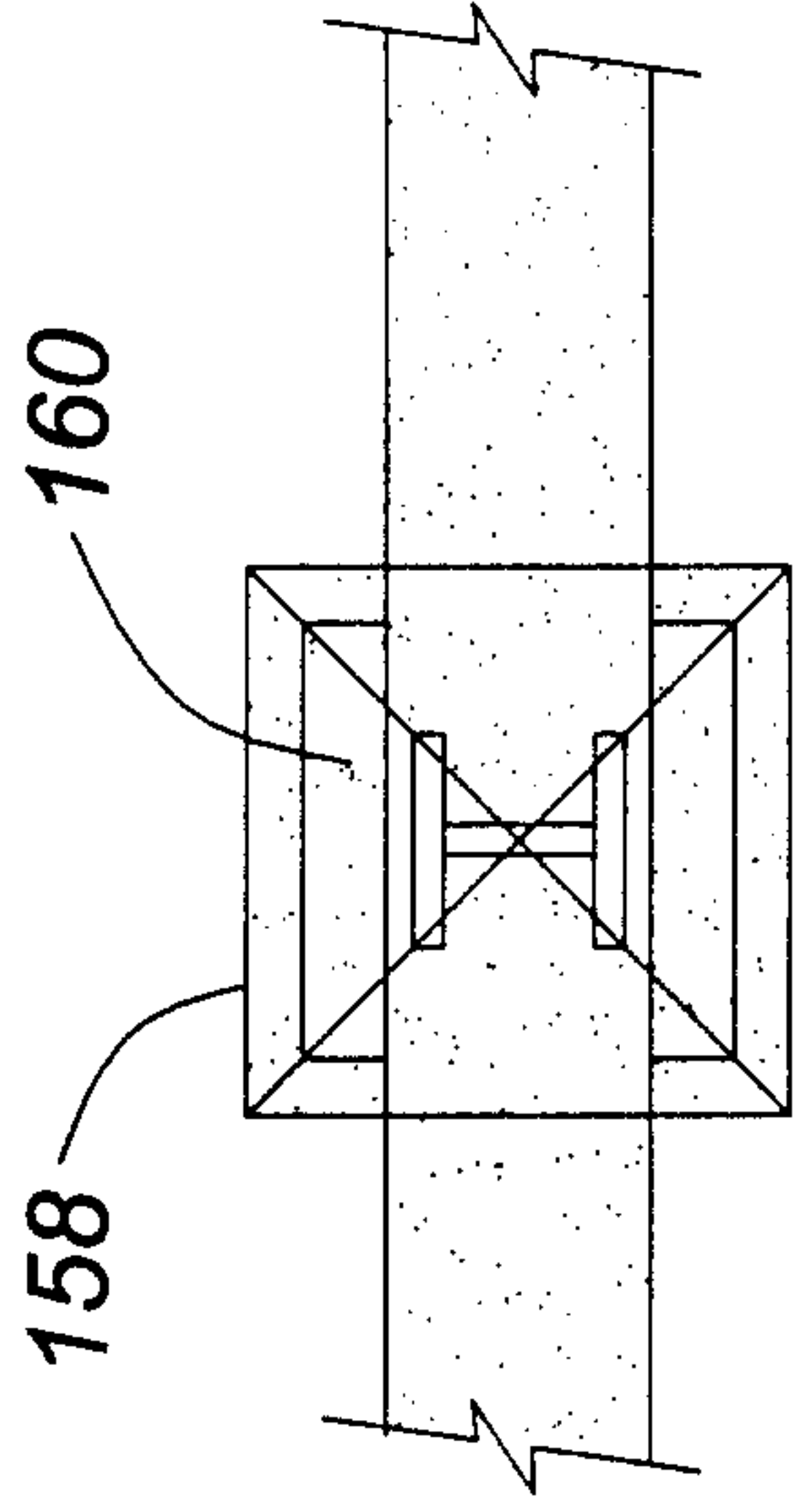

FIG. 22

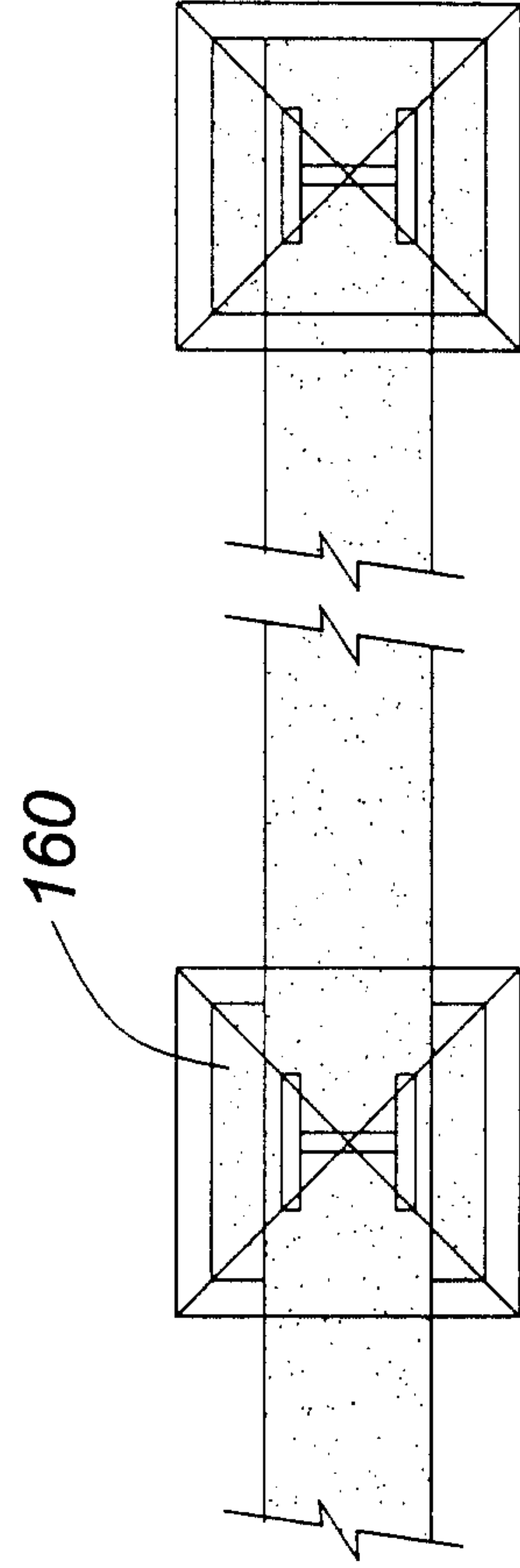

FIG. 23

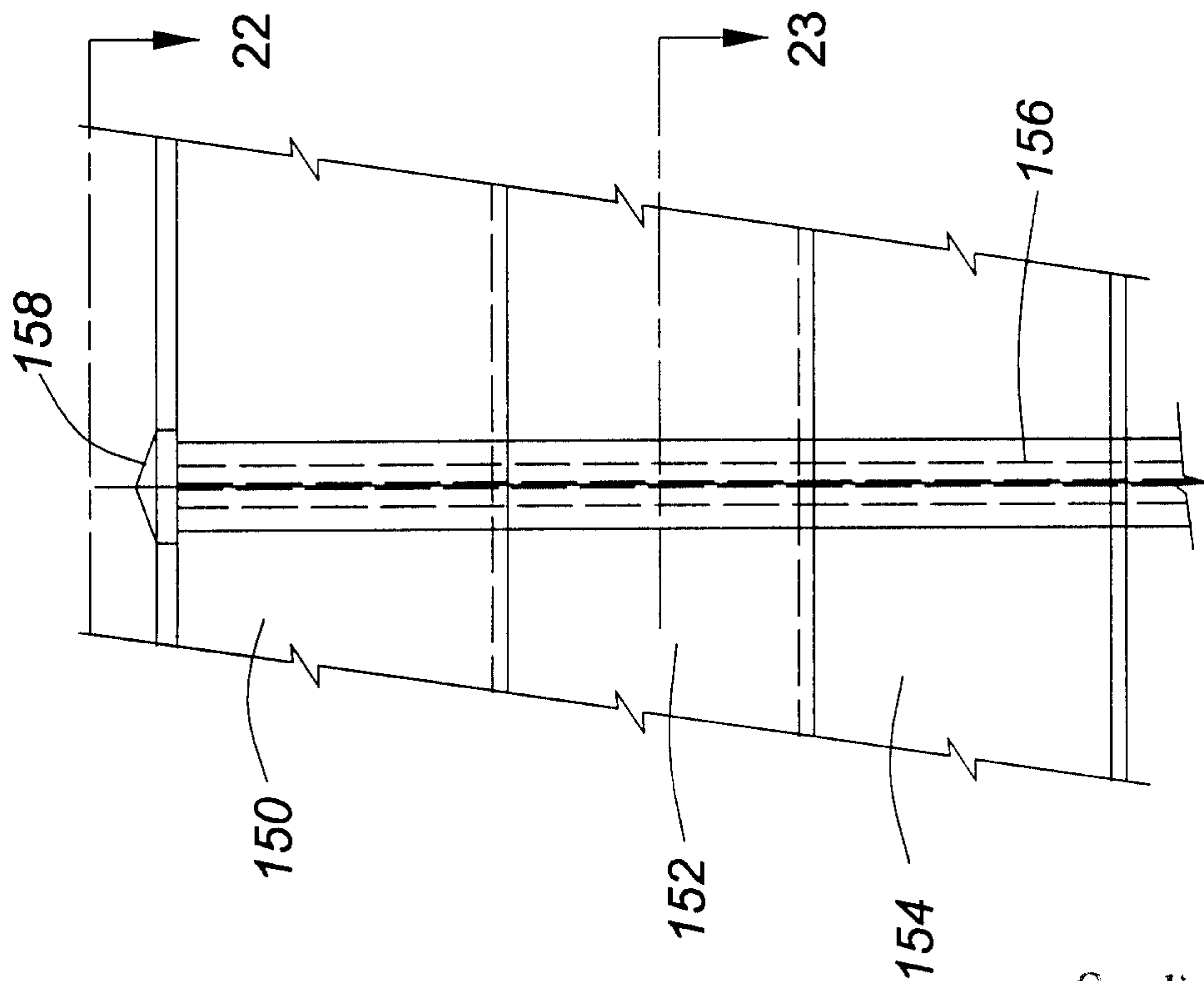

FIG. 21

