

(19) World Intellectual Property Organization  
International Bureau



(43) International Publication Date  
5 February 2004 (05.02.2004)

PCT

(10) International Publication Number  
WO 2004/011294 A1

- (51) International Patent Classification<sup>7</sup>: **B60J 10/00**
- (21) International Application Number:  
PCT/US2003/022325
- (22) International Filing Date: 17 July 2003 (17.07.2003)
- (25) Filing Language: English
- (26) Publication Language: English
- (30) Priority Data:  
60/398,454 25 July 2002 (25.07.2002) US  
10/442,470 21 May 2003 (21.05.2003) US
- (71) Applicant: **PILKINGTON NORTH AMERICA, INC.**  
[US/US]; 811 Madison Avenue, Toledo, OH 43697 (US).
- (72) Inventors: **HICKS, Thomas, S.**; 2300 Cronck Road,  
Allen, Michigan 49227 (US). **LINGLE, Thomas, M.**;  
8798 Crabb Road, Temperance, MI 48182 (US).
- (74) Agents: **SCHURR, Donald, A.** et al.; Marshall & Mel-  
horn, LLC, Four SeaGate - 8th floor, Toledo, OH 43604  
(US).
- (81) Designated States (*national*): AE, AG, AL, AM, AT, AU,  
AZ, BA, BB, BG, BR, BY, BZ, CA, CH, CN, CO, CR, CU,  
CZ, DE, DK, DM, DZ, EC, EE, ES, FI, GB, GD, GE, GH,  
GM, HR, HU, ID, IL, IN, IS, JP, KE, KG, KP, KR, KZ, LC,  
LK, LR, LS, LT, LU, LV, MA, MD, MG, MK, MN, MW,  
MX, MZ, NI, NO, NZ, OM, PG, PH, PL, PT, RO, RU, SC,  
SD, SE, SG, SK, SL, SY, TJ, TM, TN, TR, TT, TZ, UA,  
UG, UZ, VC, VN, YU, ZA, ZM, ZW.

(84) Designated States (*regional*): ARIPO patent (GH, GM, KE, LS, MW, MZ, SD, SL, SZ, TZ, UG, ZM, ZW), Eurasian patent (AM, AZ, BY, KG, KZ, MD, RU, TJ, TM), European patent (AT, BE, BG, CH, CY, CZ, DE, DK, EE, ES, FI, FR, GB, GR, HU, IE, IT, LU, MC, NL, PT, RO, SE, SI, SK, TR), OAPI patent (BF, BJ, CF, CG, CI, CM, GA, GN, GQ, GW, ML, MR, NE, SN, TD, TG).

**Declarations under Rule 4.17:**

- as to applicant's entitlement to apply for and be granted a patent (Rule 4.17(ii)) for the following designations AE, AG, AL, AM, AT, AU, AZ, BA, BB, BG, BR, BY, BZ, CA, CH, CN, CO, CR, CU, CZ, DE, DK, DM, DZ, EC, EE, ES, FI, GB, GD, GE, GH, GM, HR, HU, ID, IL, IN, IS, JP, KE, KG, KP, KR, KZ, LC, LK, LR, LS, LT, LU, LV, MA, MD, MG, MK, MN, MW, MX, MZ, NI, NO, NZ, OM, PG, PH, PL, PT, RO, RU, SC, SD, SE, SG, SK, SL, SY, TJ, TM, TN, TR, TT, TZ, UA, UG, UZ, VC, VN, YU, ZA, ZM, ZW, ARIPO patent (GH, GM, KE, LS, MW, MZ, SD, SL, SZ, TZ, UG, ZM, ZW), Eurasian patent (AM, AZ, BY, KG, KZ, MD, RU, TJ, TM), European patent (AT, BE, BG, CH, CY, CZ, DE, DK, EE, ES, FI, FR, GB, GR, HU, IE, IT, LU, MC, NL, PT, RO, SE, SI, SK, TR), OAPI patent (BF, BJ, CF, CG, CI, CM, GA, GN, GQ, GW, ML, MR, NE, SN, TD, TG)
- as to the applicant's entitlement to claim the priority of the earlier application (Rule 4.17(iii)) for the following designations AE, AG, AL, AM, AT, AU, AZ, BA, BB, BG, BR, BY, BZ, CA, CH, CN, CO, CR, CU, CZ, DE, DK, DM, DZ, EC, EE, ES, FI, GB, GD, GE, GH, GM, HR, HU, ID, IL, IN, IS, JP, KE, KG, KP, KR, KZ, LC, LK, LR, LS, LT, LU, LV, MA,

[Continued on next page]

(54) Title: APPARATUS AND METHOD FOR ATTACHING A SEAL TO AN ENCAPSULATED WINDOW ASSEMBLY

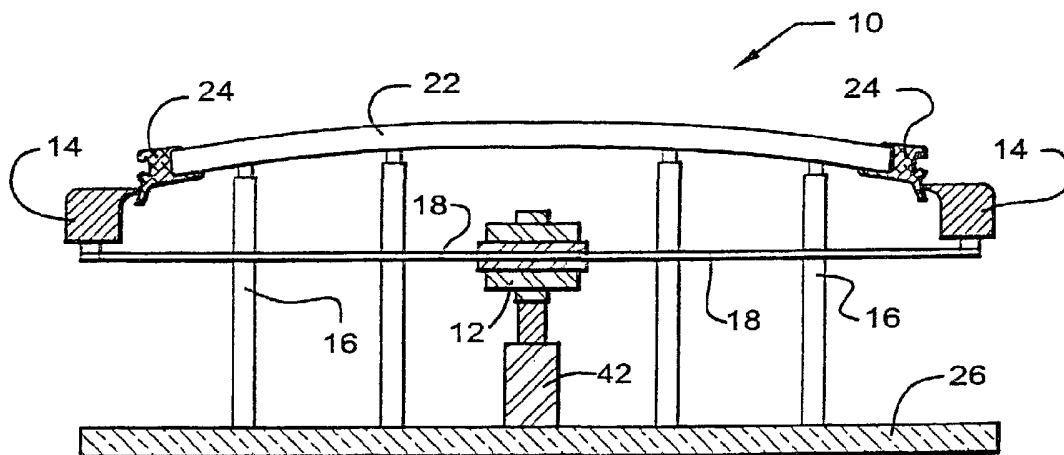

(57) Abstract: A seal attachment fixture (10) and method are provided for attaching a seal (20) to an encapsulated gasket (24) disposed on a work piece (22), for example, an automotive window assembly. The seal attachment fixture (10) includes fixture members (14), which slidably move into contact with openable lip portions (34) on the gasket, thus exposing a retention slot (32) defined therein. With the gasket retention slot (32) open, a seal (20) is then inserted within the slot.

WO 2004/011294 A1



MD, MG, MK, MN, MW, MX, MZ, NI, NO, NZ, OM, PG, PH, PL, PT, RO, RU, SC, SD, SE, SG, SK, SL, SY, TJ, TM, TN, TR, TT, TZ, UA, UG, UZ, VC, VN, YU, ZA, ZM, ZW, ARIPO patent (GH, GM, KE, LS, MW, MZ, SD, SL, SZ, TZ, UG, ZM, ZW), Eurasian patent (AM, AZ, BY, KG, KZ, MD, RU, TJ, TM), European patent (AT, BE, BG, CH, CY, CZ, DE, DK, EE, ES, FI, FR, GB, GR, HU, IE, IT, LU, MC, NL, PT, RO, SE, SI, SK, TR), OAPI patent (BF, BJ, CF, CG, CI, CM, GA, GN, GQ, GW, ML, MR, NE, SN, TD, TG)

**Published:**

- with international search report
- before the expiration of the time limit for amending the claims and to be republished in the event of receipt of amendments

For two-letter codes and other abbreviations, refer to the "Guidance Notes on Codes and Abbreviations" appearing at the beginning of each regular issue of the PCT Gazette.

APPARATUS AND METHOD FOR ATTACHING A SEAL TO AN  
ENCAPSULATED WINDOW ASSEMBLY

BACKGROUND OF THE INVENTION

5           The present invention generally relates to a seal  
attachment fixture and, more particularly, to a seal  
attachment fixture for an encapsulated window assembly.  
Most particularly, the present invention relates to a seal  
attachment fixture for attaching a seal to an automotive  
10 window with an encapsulated gasket. A method for  
operating such a seal attachment apparatus is also  
disclosed.

          Encapsulated window assemblies are well known in the  
art, where a first side of the gasket has been disposed  
15 onto at least a portion of the periphery of the window.  
The encapsulated window assembly may also include a means  
to: 1) mount the window assembly to a vehicle, 2) to  
minimize chipping and breaking of the window, and 3) to  
reduce noise, wind, and moisture from entering the  
20 vehicle. In addition, the encapsulated window assembly  
should be aesthetically pleasing.

          Although the gasket is composed of plastic/rubber,  
the gasket material is typically relatively rigid and not  
flexible enough to allow a second side of the gasket to  
25 completely prevent noise, wind, and moisture from entering  
the vehicle. For this reason it is common to provide  
additional means to more reliably seal out these  
environmental elements.

          One means that is used is to attach a more flexible  
30 plastic/rubber seal to the second side of the gasket. In  
the past the attachment of the seal to the gasket has been  
accomplished by using a gasket that has a female feature  
and/or retention slot defined along the second side,

wherein the retention slot has lips covering the retention slot opening.

5 Next, a male portion of the seal is disposed within the gasket by manually spreading the lips apart at the opening of the gasket retention slot so as to allow entry of a male portion of the seal. When the male portion of the seal is completely in place in that portion of the retention slot, the lips of the gasket are released, which results in the seal being firmly seated.

10 This manual operation is continued until the entire male portion of the seal is firmly seated within the gasket. Thus, when the window is attached to a vehicle, the exterior portion of the seal is available to completely seal an area between the gasket and a vehicle aperture mounting surface.

15 There are, however, drawbacks to the abovementioned manual attachment of the seal. For example, an installer can damage the seal, the gasket, or window during manual seal installation. Also, by attaching the seal manually within the gasket, the gasket may become bunched. Both of 20 these drawbacks can result in the leakage of noise, wind, and moisture into the vehicle compartment. In addition, manual attachment is time consuming and, therefore, costly.

25 Thus those skilled in the art continued to seek a solution to the problem of how to provide a more reliable seal attachment means for an automotive window and at a lower cost.

### 30 SUMMARY OF THE INVENTION

The present invention relates to a seal attachment fixture that is used for attaching a flexible seal to a relatively rigid gasket, the gasket having openable lip

portions on a second side of the gasket, opposite a first side of the gasket that is disposed upon a work piece. The gasket may extend around at least a portion of the work piece. The work piece is preferably an encapsulated automotive window assembly.

The fixture comprises at least one fixture member and at least one locating stop for holding a work piece. The work piece includes at least a portion of a gasket having lip portions that define a retention slot therebetween. When the fixture member is moved into contact with the gasket, the fixture member urges the lip portions to open, thus exposing the retention slot for seal insertion.

A method of attaching the seal to the gasket is provided where the gasket is disposed on the work piece that is positioned on the seal attachment fixture, the work piece having openable lip portions that define the retention slot therebetween. The method comprises: 1) urging the separate fixture member into contact with the openable lip portions of the gasket, wherein the fixture members cause the lips of the gasket to open, and thereby to expose the retention slot defined within the gasket, 2) inserting a portion of the flexible seal into the gasket by inserting a male portion of the seal between the open lip portions of the gasket, 3) moving the fixture members out of contact with the gasket, thus allowing the lips of the gasket to close over the male portion of the flexible seal, and 4) removing the work piece with attached seal from the fixture.

Further objects and advantages of the present invention will be apparent from the following description and appended claims, reference being made to the accompanying drawings forming a part of a specification,

wherein like reference characters designate corresponding parts of several views.

#### BRIEF DESCRIPTION OF THE DRAWINGS

5 Fig. 1 is a plan view of a seal attachment fixture, with arms extended, in accordance with the present invention;

10 Fig. 2 is a cross-sectional view of the seal attachment fixture of Fig. 1 with arms retracted, taken along the 2-2 line of Fig. 1;

Fig. 3 is an exploded cutaway cross-sectional view of the work piece with gasket, seal, and fixture member of Fig. 2;

15 Fig. 4 is an exploded cutaway cross-sectional view of an edge of an assembled work piece with seal disposed within the gasket, in accordance with the present invention; and

20 Fig. 5 is a cross-sectional view of the seal of Fig. 4.

#### DETAILED DESCRIPTION OF THE PREFERRED EMBODIMENTS

The present invention involves a seal attachment fixture 10 as shown in Fig. 1, where a work piece 22, for example, an automotive window with encapsulated gasket 24, is positioned within the seal attachment fixture 10.

25 The seal attachment fixture 10 comprises a plate 26 (shown in Fig. 2), a drive 42 that is attached to the plate 26, a rotating hub mechanism 12, which is rotatably attached to the drive 42, and having at least two arms 18, 30 but preferably four arms 18. A first end of each arm 18 is pivotably attached to the rotating hub mechanism 12, while a second end of each arm 18 is pivotably attached to separate fixture members 14 that are slidably attached to

at least two rails 28. The seal attachment fixture 10 also comprises at least one locating stops 16, but preferably a minimum of three (see Fig. 1), which are attached to the plate 26 and possibly adjustably attached to the plate 26.

Initially, as Fig. 1 illustrates, the rotating hub mechanism 12 is rotated by the drive 42, for example, a pneumatic cylinder, an electric motor, a hydraulic mechanism, or other rotating means that are known in the art, in a first direction to extend the arms 18. The extension of the arms 18 provides clearance between the fixture members 14 and the work piece, so that the work piece 22 can be positioned on the locating stops 16. The locating stops 16, which are positioned between the slidable fixture members 14 and inside of the gasket, are aligned with openable gasket lip portions 34 (refer to Fig. 3). With the arms 18 extended, as so described, the lips 34 are not in contact with the fixture members 14.

Next, the rotating hub mechanism 12 is rotated by the drive 42 in a second direction so that the arms 18 are retracted, which causes the fixture members 14 to come into contact with the lips 34. This results in the fixture members 14 spreading the lips 34 open and exposing a retention slot 32. The retention slot 32 is preferably defined within the gasket 24 on a side opposite a side of the gasket 24 that is disposed on the work piece 22.

A male portion 36 of a seal 20, as shown in Fig. 5, is inserted between the lips 34 and within the retention slot 32 (shown in Fig. 3) throughout the gasket 24.

Insertion of the seal 20 may be by any appropriate method, for example, manually or robotically.

When the complete male portion 36 has been inserted into the retention slot 32 around at least a portion of

the periphery of the gasket 24, the rotating hub mechanism 10 is rotated in the first direction so as to extend the arms 18. This rotation causes the arms 18 to slide the fixture members 14 out of contact with the lips 34, which close over the male portion 36 of the seal 20.

Thus, the work piece 22 is removed from the locating stops 16 with the seal male portion 36 attached to the gasket 24, while a seal exterior portion 38 is exposed outside of the gasket 24. This exterior portion 38 is then available for creating sealable contact between the work piece 22 and an automotive vehicle window aperture (not shown).

Fig. 2 illustrates a cross-sectional view of the seal attachment fixture of Fig. 1, taken along the 2-2 line of Fig. 1, however, with the arms 18 retracted. Therein are shown the fixture members 14 causing the lips 34 to be spread apart and exposing the gasket retention slot 32. Fig. 3 shows an exploded cutaway cross-sectional view of the work piece 22 with the lips 34 spread apart and the retention slot 32 exposed. It should be noted that the present invention may be practiced as shown where the fixture member 14 is pointed at the point of contact with the lips 34, but may also be non-pointed (not shown) and still be within the spirit and scope of the invention.

Fig. 4 illustrates an exploded cutaway cross-sectional view of an edge of an assembled work piece 22 with the seal 20 disposed within the gasket retention slot 32. Shown in Fig. 5 is a cross-sectional view of the seal 20 with the male portion 36 and the exterior portion 38. The encapsulated gasket 24 may be composed of any suitable thermoplastic or thermoset material. The seal 20 may be composed of any suitable extrudable plastic material.

A method of attaching the flexible seal 20 to the rigid gasket 24 is provided where the gasket 24 is disposed on the work piece 22, for example, an encapsulated window assembly, that is positioned on the seal attachment fixture 10, the work piece 22 having openable lip portions 34 that define the retention slot 32 therebetween. The method comprises: 1) urging the separate fixture members 14 into contact with the openable lip portions 34 of the gasket 24, wherein the fixture members 14 cause the lips 34 of the gasket 24 to open, and thereby to expose the retention slot 32 defined within the gasket 24, 2) inserting a portion of the flexible seal 20 into the gasket 24 by inserting a male portion of the seal 36 between the open lip portions 34 of the gasket 24, 3) moving the fixture members 14 out of contact with the gasket 24, thus allowing the lips 34 of the gasket 24 to close over the male portion 36 of the flexible seal 20, and 4) removing the work piece 22 with attached seal 20 from the fixture 10.

20

25

30

## WHAT IS CLAIMED IS:

1. A seal fixture, comprising:

at least one fixture member; and

5 at least one locating stop holding a work piece that includes at least a portion of a gasket having lip portions that define a retention slot therebetween;

10 wherein moving the fixture member into contact with the gasket urges the lip portions to open, thus exposing the retention slot for seal insertion.

2. The seal fixture of claim 1, further comprising a drive for moving the fixture member.

15 3. The seal fixture of claim 2, further comprising a rotating hub mechanism rotatably attached to the drive.

20 4. The seal fixture of claim 3, wherein the rotating hub mechanism has at least two arms, a first end of each arm pivotably attached to the rotating hub mechanism and a second end of each arm pivotably attached to separate fixture members.

25 5. The seal fixture of claim 4, wherein the fixture members are aligned with separate lip portions that are disposed on a side of the gasket opposite of where the gasket is disposed on the work piece, each fixture member being slidably attached to at least two rails.

6. The seal fixture of claim 5, wherein the seal is flexible and the gasket is relatively rigid.

7. The seal fixture of claim 6, further comprising a plate, to which the drive and the locating stops are attached.

8. The seal fixture of claim 7, wherein the locating stops are adjustably attached to the plate.

10

9. A fixture for attaching a flexible seal to a relatively rigid gasket, the relatively rigid gasket having openable lip portions that define a retention slot therebetween on a side of the gasket opposite the side of the gasket disposed upon a work piece, comprising:

15

a plate;

a drive attached to the plate;

20

a rotating hub mechanism rotatably attached to the drive, and having at least two arms, a first end of each arm pivotably attached to the rotating hub mechanism;

25

separate fixture members pivotably attached to a second end of each arm, where the fixture members are aligned with the lip portions of the seal and each fixture member is slidably attached to at least two rails; and

at least three locating stops that are adjustably attached to the plate.

30

10. The fixture of claim 9, wherein the gasket is encapsulated onto the periphery of the work piece, which work piece is an automotive glazing.

5 11. A method of attaching a seal to a gasket, the method comprising:

urging a fixture member into contact with an openable lip portion of the gasket;

10 inserting a portion of the seal between the open lip portion; and

moving the fixture member out of contact with the gasket.

12. The method of claim 11, further comprising:

15 initially placing a work piece onto locating stops.

13. The method of claim 12, wherein urging the fixture member includes rotating a hub mechanism.

20

14. The method of claim 13, wherein rotating the hub mechanism includes moving a drive.

25 15. The method of claim 14, wherein rotating the hub mechanism includes aligning the fixture members and separate lip portions.

30 16. The method of claim 15, wherein urging the fixture members includes sliding the fixture members on rails.

17. The method of claim 16, further comprising adjusting the locating stops.

18. The method of claim 17, wherein inserting the  
5 fixture members includes a robot.

19. The method of claim 18, further comprising removing the work piece from the locating stops.

10

15

20

25

30

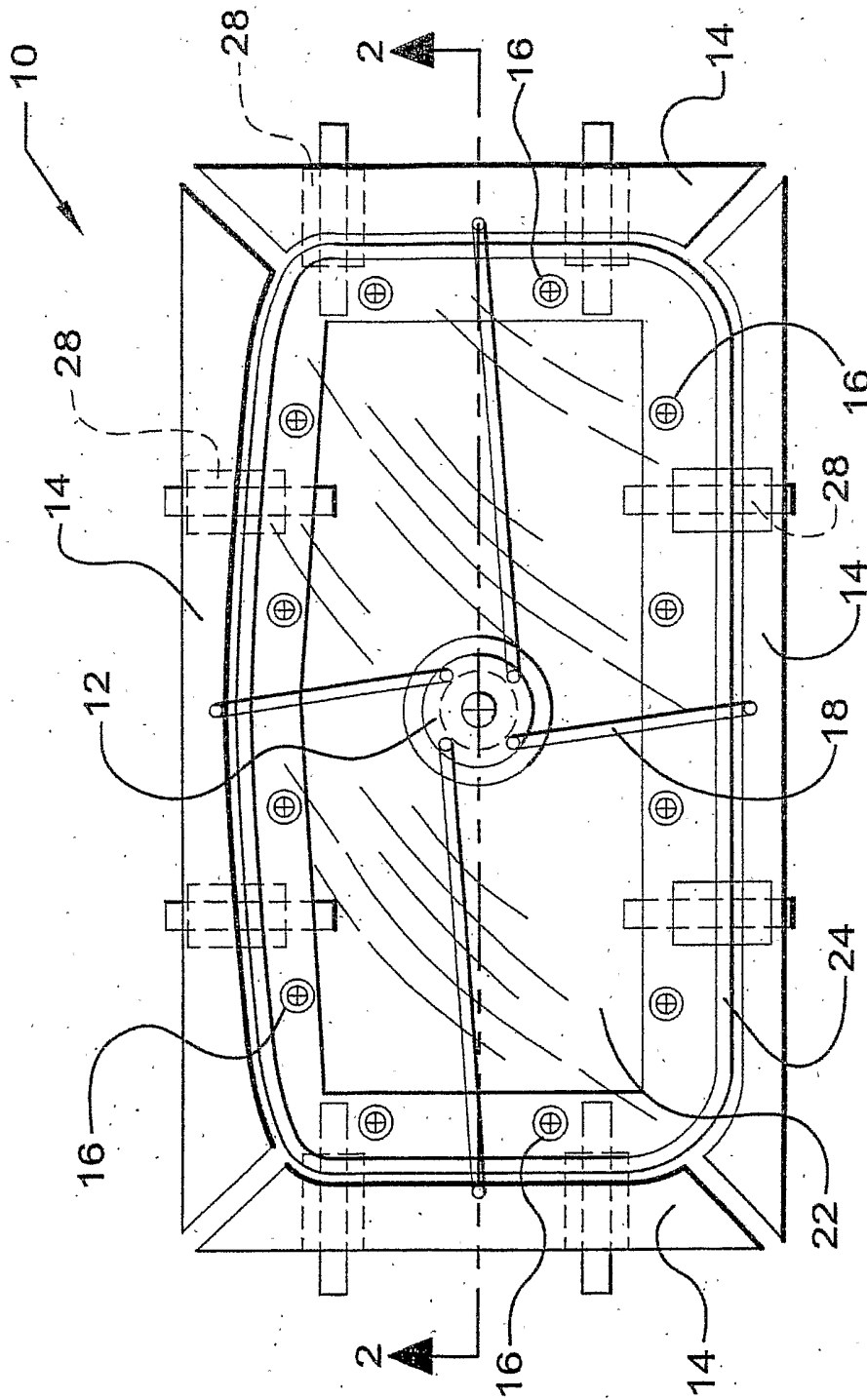

FIG. 1

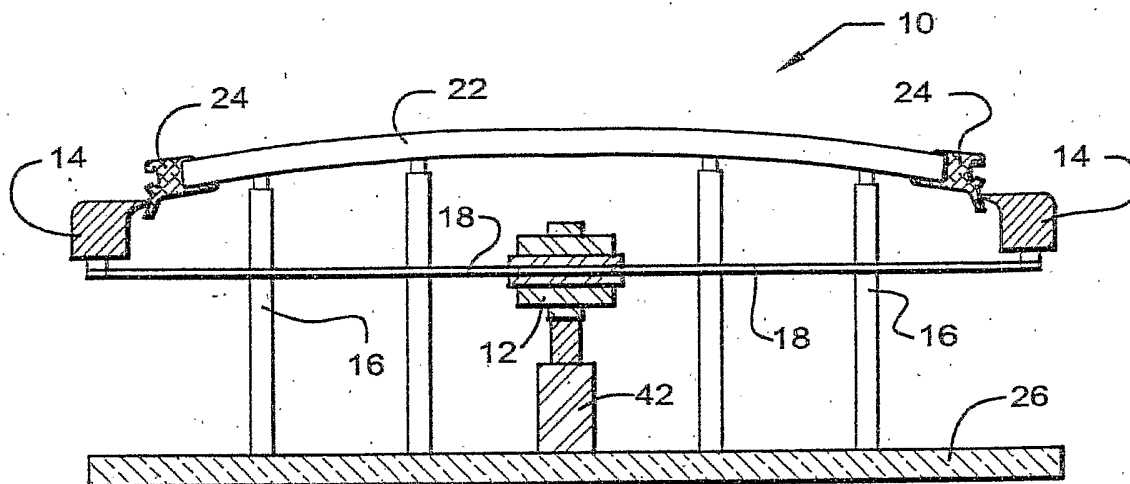

FIG. 2

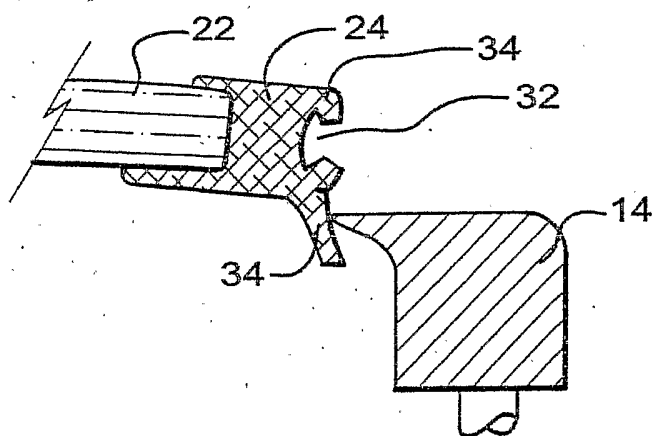

FIG. 3

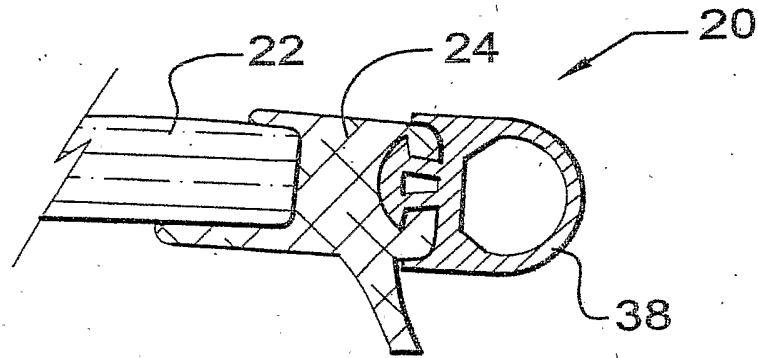

FIG. 4

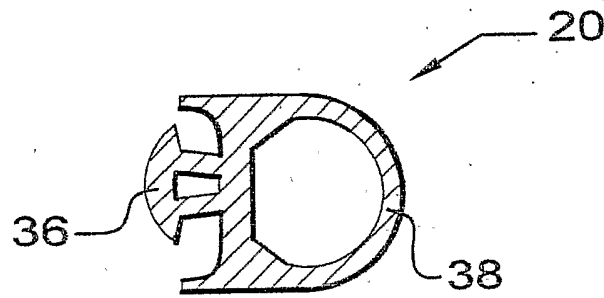

FIG. 5

# INTERNATIONAL SEARCH REPORT

International Application No  
PCT/US 03/22325

**A. CLASSIFICATION OF SUBJECT MATTER**  
IPC 7 B60J10/00

According to International Patent Classification (IPC) or to both national classification and IPC

**B. FIELDS SEARCHED**

Minimum documentation searched (classification system followed by classification symbols)  
IPC 7 B60J B23P B25B

Documentation searched other than minimum documentation to the extent that such documents are included in the fields searched

Electronic data base consulted during the international search (name of data base and, where practical, search terms used)

WPI Data, PAJ, EPO-Internal

**C. DOCUMENTS CONSIDERED TO BE RELEVANT**

Category °	Citation of document, with indication, where appropriate, of the relevant passages	Relevant to claim No.
X	GB 1 517 917 A (DIXON INT LTD) 19 July 1978 (1978-07-19) page 3, line 37 - line 55 figures 1,6	11
A	GB 1 447 491 A (MARLER HALEY EXPOSYSTEMS LTD) 25 August 1976 (1976-08-25) page 1, line 12 - line 46 page 2, line 27 - line 32 figure 1	11
A	US 4 738 482 A (BOEHM HORST ET AL) 19 April 1988 (1988-04-19) column 5, line 16 - line 50 figure 2	1,9,11
	-/--	

Further documents are listed in the continuation of box C.

Patent family members are listed in annex.

° Special categories of cited documents :

- \*A\* document defining the general state of the art which is not considered to be of particular relevance
- \*E\* earlier document but published on or after the international filing date
- \*L\* document which may throw doubts on priority claim(s) or which is cited to establish the publication date of another citation or other special reason (as specified)
- \*O\* document referring to an oral disclosure, use, exhibition or other means
- \*P\* document published prior to the international filing date but later than the priority date claimed

- \*T\* later document published after the international filing date or priority date and not in conflict with the application but cited to understand the principle or theory underlying the invention
- \*X\* document of particular relevance; the claimed invention cannot be considered novel or cannot be considered to involve an inventive step when the document is taken alone
- \*Y\* document of particular relevance; the claimed invention cannot be considered to involve an inventive step when the document is combined with one or more other such documents, such combination being obvious to a person skilled in the art.
- \* & \* document member of the same patent family

Date of the actual completion of the international search

19 November 2003

Date of mailing of the international search report

28/11/2003

Name and mailing address of the ISA

European Patent Office, P.B. 5818 Patentlaan 2  
NL - 2280 HV Rijswijk  
Tel. (+31-70) 340-2040, Tx. 31 651 epo nl,  
Fax: (+31-70) 340-3016

Authorized officer

Verkerk, E

# INTERNATIONAL SEARCH REPORT

International Application No  
PCT/US 03/22325

C.(Continuation) DOCUMENTS CONSIDERED TO BE RELEVANT		
Category °	Citation of document, with indication, where appropriate, of the relevant passages	Relevant to claim No.
A	EP 0 155 642 A (METZELER KAUSCHUK) 25 September 1985 (1985-09-25) page 3, line 31 -page 4, line 10 figure 1 -----	1,9,11
A	DE 199 23 725 C (WEBASTO VEHICLE SYS INT GMBH) 20 July 2000 (2000-07-20) column 2, line 68 -column 3, line 26 figure 2 -----	1,9,11

INTERNATIONAL SEARCH REPORT

International Application No  
PCT/US 03/22325

Patent document cited in search report		Publication date		Patent family member(s)	Publication date
GB 1517917	A	19-07-1978	CA	1033941 A1	04-07-1978
			FR	2303934 A1	08-10-1976
GB 1447491	A	25-08-1976	NONE		
US 4738482	A	19-04-1988	DE	3506009 A1	28-08-1986
			BR	8506062 A	09-12-1986
			CA	1237745 A1	07-06-1988
			ES	8701060 A1	16-02-1987
			FR	2577484 A1	22-08-1986
			GB	2171442 A ,B	28-08-1986
			IT	1185955 B	18-11-1987
			JP	1680411 C	13-07-1992
			JP	3044925 B	09-07-1991
			JP	61193926 A	28-08-1986
			MX	164694 B	18-09-1992
			NL	8502646 A ,B,	16-09-1986
			SE	461141 B	15-01-1990
SE	8504086 A	22-08-1986			
EP 0155642	A	25-09-1985	DE	3410193 A1	26-09-1985
			EP	0155642 A2	25-09-1985
			ES	285481 U	01-09-1985
			JP	60213521 A	25-10-1985
DE 19923725	C	20-07-2000	DE	19923725 C1	20-07-2000