

(No Model.)

2 Sheets—Sheet 1.

P. G. COTTER, L. HOLLADAY & R. J. DUNCAN.
PILOT BAR LIFTER.

No. 522,452.

Patented July 3, 1894.

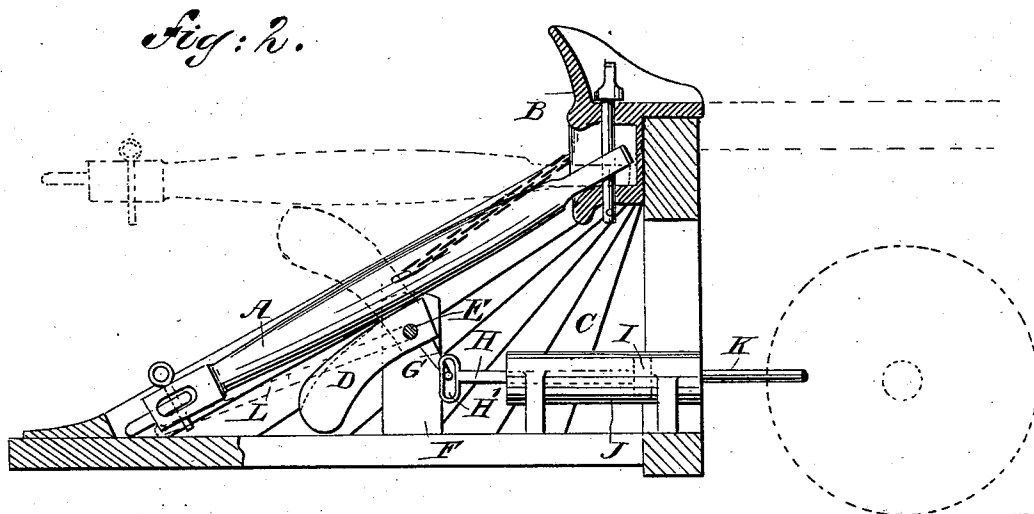
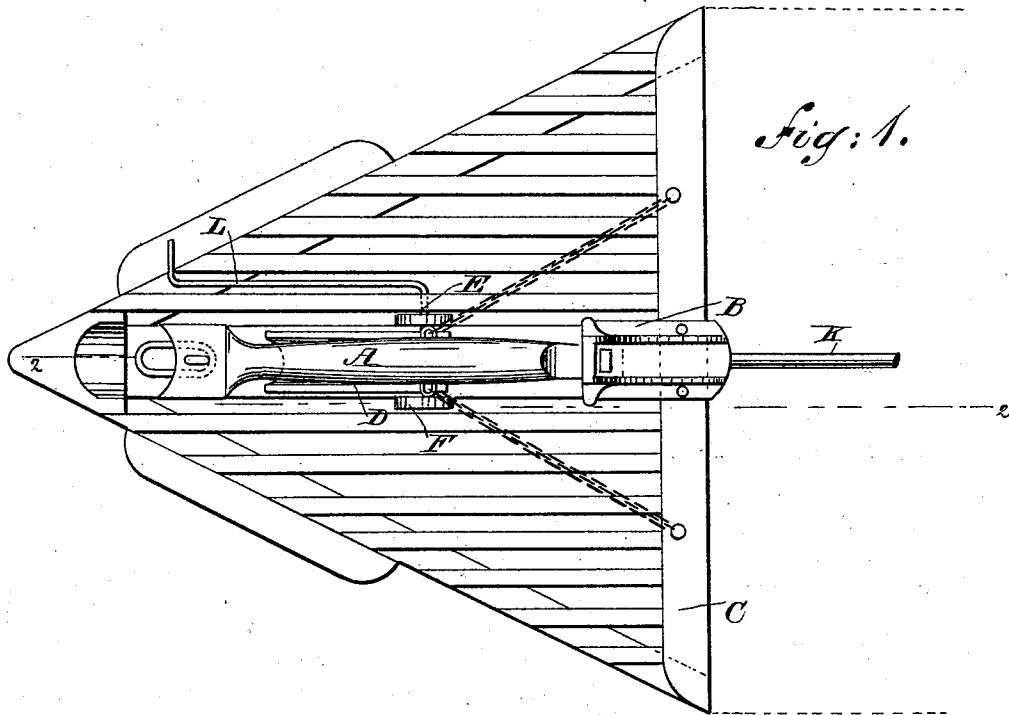

WITNESSES:

Chas. Nida.
W. Sedgwick

INVENTORS

P. G. Cotter
L. Holladay

BY *R. J. Duncan*

Munn & Co
ATTORNEYS.

(No Model.)

2 Sheets—Sheet 2.

P. G. COTTER, L. HOLLADAY & R. J. DUNCAN.
PILOT BAR LIFTER.

No. 522,452.

Patented July 3, 1894.

Fig: 3.

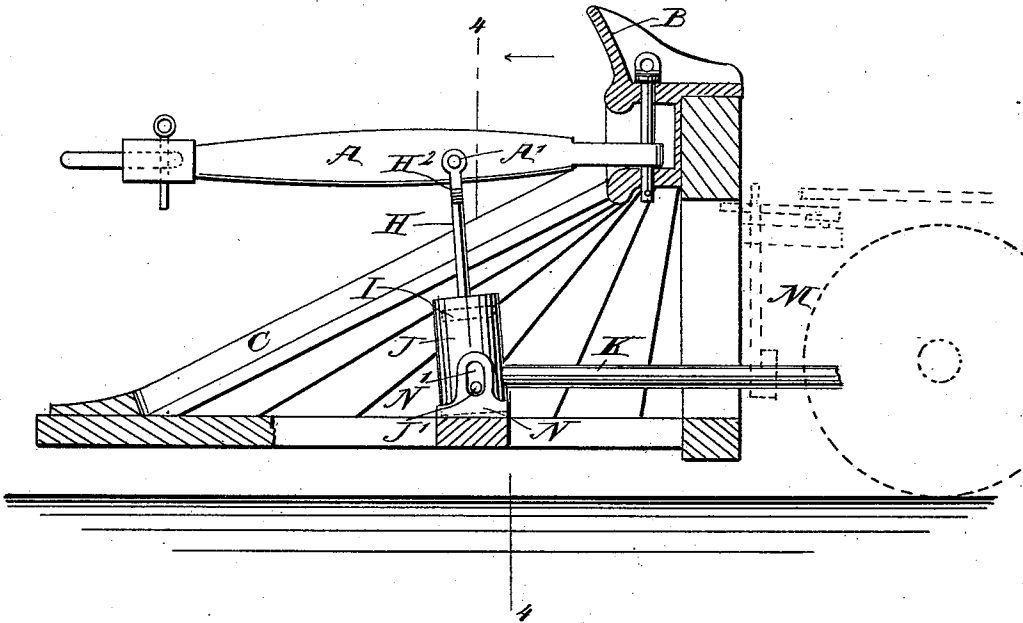
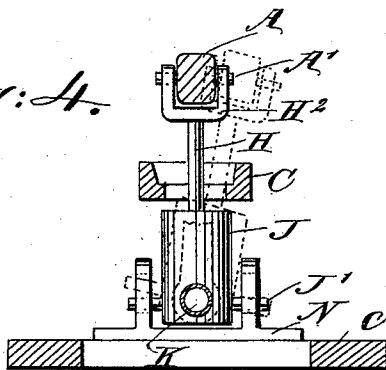

Fig: 4.



WITNESSES:

Chas. Nida.
C. Sedgwick

INVENTORS

P. G. Cotter
L. Holladay
R. J. Duncan

BY

Munn & Co.
ATTORNEYS.

UNITED STATES PATENT OFFICE.

PETER G. COTTER, OF YUMA, LEONIDAS HOLLADAY, OF PIMA, AND RANSOM J. DUNCAN, OF YUMA, ARIZONA TERRITORY.

PILOT-BAR LIFTER.

SPECIFICATION forming part of Letters Patent No. 522,452, dated July 3, 1894.

Application filed July 8, 1893. Serial No. 479,937. (No model.)

To all whom it may concern:

Be it known that we, PETER G. COTTER, of Yuma, in the county of Yuma, LEONIDAS HOLLADAY, of Pima, in the county of Pima, and RANSOM J. DUNCAN, of Yuma, in the county of Yuma, Territory of Arizona, have invented a new and Improved Pilot-Bar Lifter and Adjuster, of which the following is a full, clear, and exact description.

The invention relates to pilot bars of locomotives, and its object is to provide a new and improved device for conveniently and easily lifting and holding the pilot bar in position for coupling, without a brakeman, other man or operator being compelled to mount the cowcatcher or assume any dangerous position to make the coupling; as at present practiced.

The invention consists of a lifting mechanism adapted to engage the pilot bar and under the control of an operator, either in the cab of the locomotive or upon its front end, but preferably by the locomotive engineer or other man or operator in the cab of same.

The invention also consists of certain parts and details, and combinations of the same, as will be hereinafter described and then pointed out in the claims.

Reference is to be had to the accompanying drawings, forming a part of this specification, in which similar letters of reference indicate corresponding parts in all the figures.

Figure 1 is a plan view of the improvement. Fig. 2 is a sectional side elevation of the same, on the line 2—2 of Fig. 1. Fig. 3 is a sectional side elevation of another form of the improvement; and Fig. 4 is a cross sectional elevation of the same on line 4—4 of Fig. 3.

As illustrated in Figs. 1 and 2, the pilot bar or coupling A, is pivoted at one end in the usual drawhead B, secured on the cowcatcher C, of the locomotive, as plainly shown in the drawings. The under side of the pilot bar A is engaged by the top surface of a grooved cam D, secured on a transversely extending shaft E, mounted to turn in suitable bearings F, erected on the cowcatcher C, under the bars thereof, as shown in the drawings. From the pivot end of the cam D extends approximately at right angles to the cam an arm G, engaging the slotted end H', of a piston rod H, car-

rying a piston I, mounted to slide longitudinally in a cylinder J, likewise mounted on the cowcatcher near the inner end thereof as indicated in Fig. 2. This cylinder J is connected by a pipe K, with a motive agent under the control of the operator, preferably the engineer in the cab of the locomotive, so that when the motive agent is permitted to pass into the pipe K it flows to the cylinder J to exert a pressure therein on the piston I to move the latter forward, so that the head H' of the piston rod H imparts a swinging motion to the arm G and consequently an upward swinging motion to the cam D. As the latter engages the under side of the pilot bar or coupling link A, the latter is caused to swing upward into an approximately horizontal position ready for coupling.

To provide against the possible absence of a motive agent, in compressed air, steam, water, gas or electricity, instead of actuating the cam D by such agents—agent or fluid pressure, it may be actuated by hand by a suitable mechanism under the control of the engineer or fireman, other man or operator upon the locomotive. It may also be actuated from the side of the cowcatcher, and for this purpose we prefer the arrangement shown in the drawings, the shaft E, being provided at one outer end with a crank arm L, which when turned upward, causes a like upward swinging of the cam D to lift the pilot bar A, as above described. After the pilot bar has been coupled in the usual manner to the car or other vehicle, then the cam D may be returned to its normal position by turning the shaft E in an opposite direction. It will be seen by this arrangement, that the operator is not obliged to step on the cowcatcher to raise the pilot bar and consequently his life is not endangered.

It is understood that the pilot bars of locomotives are usually very heavy pieces of iron, so located upon the pilot, that to lift which for the purpose of making a coupling with it, a man must stand to one side from six to twenty-four inches in a leaning position that makes the act of coupling it the most dangerous of any coupling made in railway service or practice.

With the device described, the operator is

not compelled to assume an angular, awkward, or dangerous position, and has while making the coupling the full use of all his limbs, with body in an erect position, in consequence of having no lifting to do in connection with the act of coupling, as the raising of the pilot bar is done by the special mechanism described.

The cylinder J instead of being fixed to the locomotive engine, as shown in Fig. 2, may be pivoted thereto so as to be capable of an oscillating or swinging motion in an essentially vertical plane, in order to accommodate for the movement of the pilot bar to either side. The cylinder in this case would be an upright oscillating cylinder, and the upper end of the piston rod could be connected directly with the pilot bar by means of a lug or boss on the latter. This construction is illustrated in Figs. 3 and 4, in which the upright cylinder J is provided with side trunnions J' supported in bearings N, said bearings being slotted, as shown at N', so that the cylinder can assume a laterally inclined position, as indicated by dotted lines in Fig. 4. The piston rod H is provided with a fork H² which has pivotal connection with the pilot bar A by means of lugs A' secured to the said bar. M indicates a suitable mechanism having an operating connection to the engineer's cab, and the said mechanism is constructed to turn the supply pipe K and thereby incline the cylinder J to swing the pilot bar to either side.

Having thus described our invention, we claim as new and desire to secure by Letters Patent—

1. A pilot bar attachment, comprising a cylinder mounted on the engine so as to be capable of an oscillating or swinging motion for the accommodation of the movement of the pilot bar to either side, the cylinder being connected with a supply of a motive fluid, a piston adapted to move in the cylinder, and an operative connection between the pilot bar and the piston, substantially as described.

2. In a locomotive engine, the combination with the pilot bar, of a cylinder held on the engine and connected with a supply of a motive fluid, a piston constructed to move in the cylinder, a cam pivoted to the pilot and operatively connected with the said piston, said cam being adapted to engage the pilot bar, and a handle having an operative connection with the cam to lift the latter and the pilot bar independently of the mechanism operated by the piston, substantially as described.

3. A pilot bar attachment, comprising a cylinder held on the engine and connected with a supply of a motive fluid, a piston constructed to move in the cylinder, a piston rod secured to the piston, a cam pivoted to the pilot and adapted for engagement with the pilot bar, and an arm secured to the cam at the pivot end thereof, said arm having a slot and pin connection with the outer end of the piston rod, substantially as described.

PETER G. COTTER.
LEONIDAS HOLLADAY.
RANSOM J. DUNCAN.

Witnesses:

O. H. WILLIS,
C. V. CONNOR.