

L. ROBINSON.
 SWIMMING SHOE.
 APPLICATION FILED NOV. 6, 1912.

1,059,565.

Patented Apr. 22, 1913.

2 SHEETS—SHEET 1.

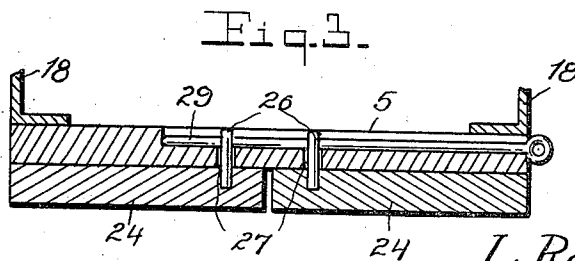
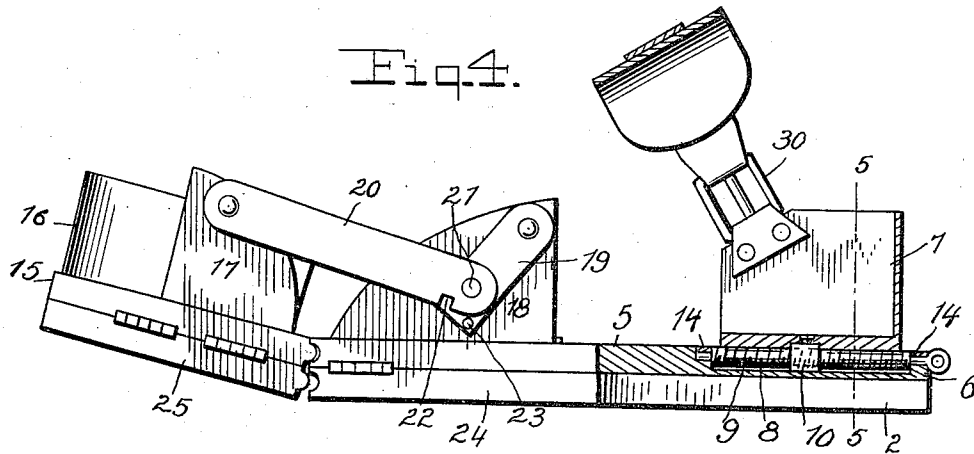
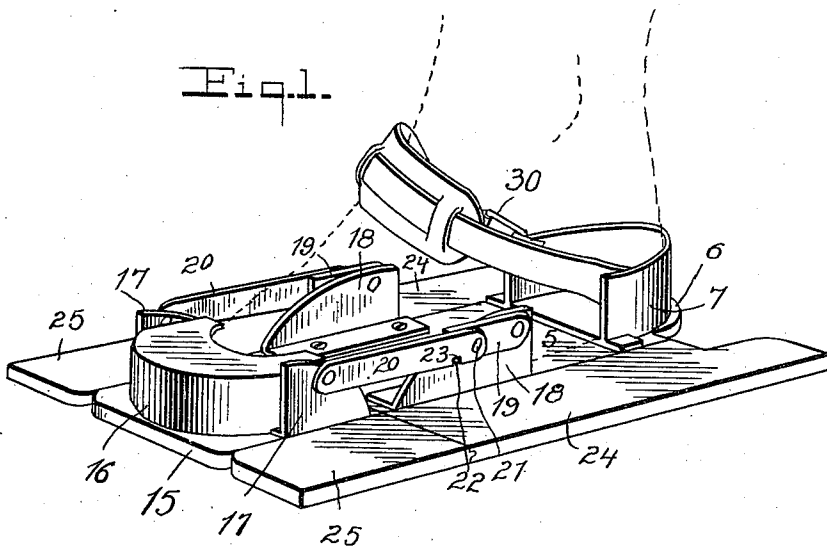

Witnesses
 Robert M. Sutphen.
 A. D. Lind.

Inventor
 L. Robinson.

By *Watson E. Coleman.*
 Attorney

L. ROBINSON.
 SWIMMING SHOE.
 APPLICATION FILED NOV. 6, 1912.

1,059,565.

Patented Apr. 22, 1913.

2 SHEETS—SHEET 2.

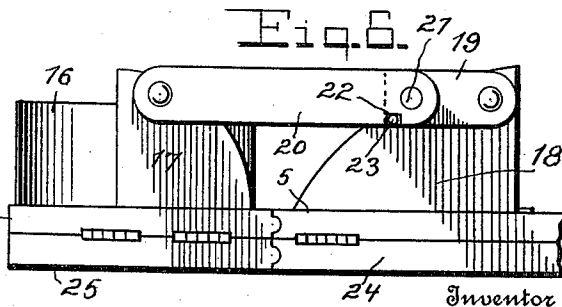
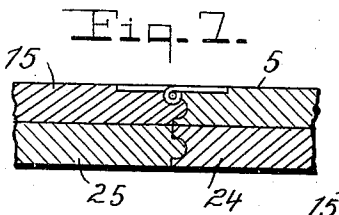
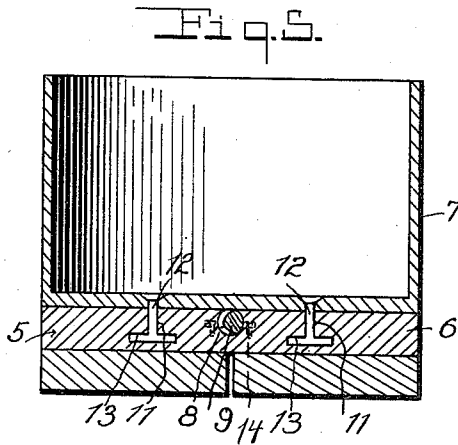
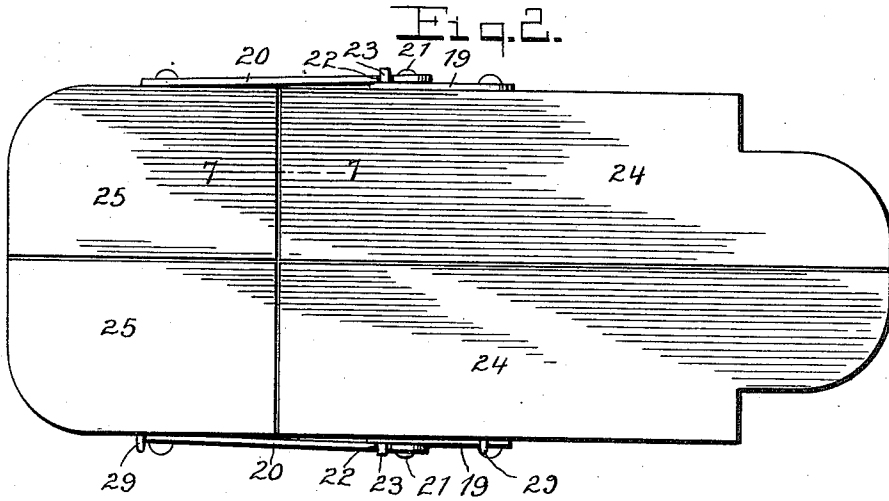

L. Robinson.

Witnesses
 Robert M. Stephens
 Ad. Hind.

By *Watson E. Coleman*
 Attorney

UNITED STATES PATENT OFFICE.

LLEWELLYN ROBINSON, OF NEW YORK, N. Y.

SWIMMING-SHOE.

1,059,565.

Specification of Letters Patent.

Patented Apr. 22, 1913.

Application filed November 6, 1912. Serial No. 729,862.

To all whom it may concern:

Be it known that I, LLEWELLYN ROBINSON, a citizen of the United States, residing at New York, in the county of New York and State of New York, have invented certain new and useful Improvements in Swimming-Shoes, of which the following is a specification, reference being had to the accompanying drawings.

This invention relates to an improved swimmer's shoe and has for its primary object to provide a device of this character having certain structural characteristics which will admit of the wearer walking upon land without necessitating the removal of the shoe or causing any discomfort.

Another and more specific object of the invention is to provide a swimmer's shoe consisting of a body or sole member and a toe member pivotally connected to said body member, and side wings connected to and foldable beneath the body and toe members.

Still another object of the invention resides in the provision of improved means for adjusting the heel engaging member upon the body or sole portion of the shoe whereby the device may be readily fitted to the foot.

A still further object of the invention is to produce a swimmer's shoe which is simple and inexpensive in construction, strong, durable and efficient in practical use and provides means whereby the body may be speedily impelled through the water.

With the above and other objects in view as will become apparent as the description proceeds, the invention consists in certain constructions, combinations and arrangements of the parts that I shall hereinafter fully describe and claim.

For a full understanding of the invention, reference is to be had to the following description and accompanying drawing, in which—

Figure 1 is a perspective view of my improved swimmer's shoe, showing the same attached to the foot; Fig. 2 is a bottom plan view thereof showing the side wings folded; Fig. 3 is a section taken on the line 3—3 of Fig. 2; Fig. 4 is a side elevation partly in section, showing the toe member tilted or inclined with relation to the sole or body member. Fig. 5 is a section taken on the line 5—5 of Fig. 4. Fig. 6 is an enlarged fragmentary side elevation showing the

relative positions of the link bars which connect the toe and sole members; and Fig. 7 is a detail section taken on the line 7—7 of Fig. 2.

Referring in detail to the drawing, 5 designates the sole or body member of my improved shoe which is preferably formed of wood or other light material and is provided at one end with a semicircular extension 6. Upon this extension of the sole member, the adjustable heel receiving member 7 is mounted. The upper surface of the extension 6 is longitudinally grooved or channeled as indicated at 8 to receive the worm 9 which engages with the worm nut 10 fixed to the under side of the base of the heel member 7. The extension 6 is further provided in its upper surface with the channels 11 which are located upon opposite sides of the central channel 8 and in parallel relation thereto. These latter channels 11 have undercut side walls to receive the heads 13 of the studs 12 which are fixed to the base of the heel member 7. The adjusting worm 9 is retained in its position in the groove 8 by means of the bearing straps 14.

To the forward end of the sole or base member 5, the toe member 15 is pivotally connected. This member carries the hood or housing 16 to receive the toes of the foot, said housing being suitably secured to the vertical flanges of the angle plates 17, which are secured upon said toe member at its opposite edges. Similar angle plates 18 are also secured upon the base or sole member 5, at its forward end and upon the vertical flanges of these angle plates, the link bars 19 are pivotally mounted at one of their ends. Link bars 20 are also pivotally connected at their forward ends to the vertical flanges of the plates 17 on the toe member 15, the other ends of these latter bars being pivotally connected to the links 19 as indicated at 21. The lower edges of the link bars 20 adjacent their rear ends are provided with notches 22 to receive the pins or studs 23 provided upon the links 19. These pins act as stops and limit the swinging or pivotal movement of the toe member 15 with relation to the base or sole member 5 in one direction.

Wings 24 are hingedly secured to the longitudinal edges of the sole member 5, said wings being coextensive in length with said

60

65

70

75

80

85

90

95

100

105

110

member. Similar wings 25 are also hingedly secured upon the longitudinal edges of the toe member 15. The abutting ends of these wings 24 and 25 are provided with interlocking tongues and grooves so that when the device is in condition for use, the same constitute in effect a single longitudinally extending wing upon each side of the shoe.

In order to permit of the wearer walking upon land without necessitating the removal of the shoe from the foot, the side wings 24 and 25 are adapted to be folded beneath the sole and toe members 5 and 15, as shown in Fig. 2 of the drawing. The wings 24 which are attached to the member 5 are provided adjacent to their outer longitudinal edges and upon their under sides with the eyes 26 which are adapted to be received in the recesses or openings 27 provided in the sole member 5. These recesses open into a transversely extending groove 28 in the upper surface of the member 5. The eyes 26 when the wings are in folded position project into this groove and through said eyes the locking rod 29 is adapted to be inserted. Thus it will be apparent that the wings 24 are securely locked beneath the bottom of the shoe. Additional locking means, similar in all respects to that above described is provided for the toe wings 25. When the side wings have been thus folded, the wearer may walk upon the land without discomfort, the toe member 15 swinging freely upon the forward end of the base or sole member 5, the links 19 and 20 moving relative to each other, and the toe member assuming the inclined position, shown in Fig. 4.

The adjustable heel member 7 is also provided with a strap and buckle indicated at 30, said strap being adapted to be disposed over the instep of the foot and securely buckled at its free end to retain the heel of the foot in the member 7.

From the foregoing, it is believed that the construction of the device will be readily understood, and its operation in use apparent. When the device is applied to the foot as shown in Fig. 1, and the wings 24 and 25 moved outwardly, a broad flat surface is produced, which in the backward movement of the foot in the action of swimming will displace a comparatively large volume of water, and thus serve to accelerate the progress of the swimmer.

The device is comparatively light in weight and will in no manner interfere with the free movement of the swimmer's foot, the side wings 24 and 25 moving freely under the pressure of the water thereagainst when the foot is drawn up or reversed for another stroke. The heel member may be readily adjusted upon the body of the device to permit of the application of the shoe to

feet of various sizes. As above described, it will also be seen that the wings 24 and 25 may be readily arranged in position beneath the bottom of the shoe and securely locked so that the wearer may walk upon the land without removing the shoe and without suffering any discomfort therefrom. As the device consists of but few parts which are of simple form, it will be obvious that the same can be produced at small cost. It will also be appreciated that the invention is highly efficient in actual use and will efficiently perform the functions for which the same is provided.

While I have shown and described the preferred construction and arrangement of the several elements, it will be understood that the invention is susceptible of considerable modification without departing from the essential features or sacrificing any of the advantages thereof.

Having thus described the invention, what is claimed is:

1. A swimmer's shoe comprising a sole member, a toe member pivotally connected to the forward end of the sole member, and connecting means between said members to prevent movement of the toe member in one direction out of longitudinal alinement with the sole member.

2. A swimmer's shoe comprising a sole member, means for securing the same upon the bottom of the foot, wings hingedly secured to the longitudinal edges of said sole member and foldable beneath the same, and means for locking the wings in their folded position.

3. A swimmer's shoe comprising a sole member, a toe member pivotally connected to one end of the sole member, for movement with relation thereto, wings hingedly connected to the longitudinal edges of the sole and toe members, and foldable beneath the same, means for locking said wings in their folded position, and means for attaching the shoe to a foot.

4. A swimmer's shoe comprising a sole member, a toe member pivotally connected to one end of said sole member, link connections between said sole and toe members to prevent pivotal movement of the latter member in one direction out of longitudinal alinement with the sole member, and means for attaching the shoe to a foot.

5. A swimmer's shoe comprising a sole member, a toe member pivotally connected to one end of said sole member, plates secured to said members at their longitudinal edges, link bars pivotally mounted upon said plates and pivotally connected to each other to permit of the pivotal movement of the toe member in one direction, a stop carried by one of the link bars to engage with the other link bar and prevent pivotal movement of the toe member in the opposite direction out

of longitudinal alinement with the sole member, and means for attaching the shoe to the foot.

5 6. A swimmer's shoe comprising a sole member, side wings hingedly secured to the longitudinal edges of said member and foldable beneath the same, said sole member having a transverse groove in its upper surface and spaced openings communicating there-
10 with, eyes carried by the wings to be received in said openings when the wings are folded, and a locking rod adapted to be positioned in said groove and inserted through the eyes to lock the wings in their folded
15 position.

7. A swimmer's shoe comprising a sole member, a heel receiving member, means for

adjusting said latter member, longitudinally upon the sole member, a toe member pivotally connected to one end of the sole member, means for preventing movement of the toe member in one direction out of longitudinal alinement with the sole member, side wings hingedly connected to the longitudinal edges of said sole and toe members, and independent locking means for said wings to lock the same in their folded position beneath the sole and toe members, respectively.

In testimony whereof I hereunto affix my signature in the presence of two witnesses.

LLEWELLYN ROBINSON.

Witnesses:

M. C. LYDDANE,
GEO. S. LIVINGSTON.

Copies of this patent may be obtained for five cents each, by addressing the "Commissioner of Patents, Washington, D. C."
