



(12) **EUROPEAN PATENT APPLICATION**

(88) Date of publication A3:  
**07.08.2002 Bulletin 2002/32**

(51) Int Cl.7: **F02N 15/06**

(43) Date of publication A2:  
**02.08.2000 Bulletin 2000/31**

(21) Application number: **00100643.6**

(22) Date of filing: **13.01.2000**

(84) Designated Contracting States:  
**AT BE CH CY DE DK ES FI FR GB GR IE IT LI LU  
MC NL PT SE**  
Designated Extension States:  
**AL LT LV MK RO SI**

(71) Applicant: **DUCATI ENERGIA S.p.A.**  
**40132 Bologna (IT)**

(72) Inventor: **Berghi, Alessandro**  
**40132 Bologna (IT)**

(30) Priority: **27.01.1999 IT MI990151**

(74) Representative: **Coloberti, Luigi**  
**Via E. de Amicis No. 25**  
**20123 Milano (IT)**

(54) **Starter device for internal combustion engines**

(57) A starter device for internal combustion engines comprises a drive shaft (11), a control assembly (13) for a pinion gear (17) rotatingly and axially movable on the driver shaft (11), and a centrifugally actuated locking unit (16) fastened to the drive shaft (11) to retarding the control assembly (13) from backward sliding during starting of the engine. The control assembly (13) comprises the pinion gear (17), and a thrust element (19) coupled to the drive shaft (11) by helical splines (21), and an intermediate unidirectional roller clutch

(20). The centrifugally actuated locking unit (16) comprises face to face arranged locking members (26, 27) radially sliding into an open cage (25) fastened to rotate with the drive shaft (11). Each locking member (26, 27) is provided with an arch-shaped weight portion (30) and a tooth member (32) to stop the thrust element (19), connected by at least one intermediate arm (31). Guide means (33, 34; 42) are provided on the locking members (26, 27) and the guide cage (25) to radially guide the same locking members (26, 27) during movement under centrifugal forces.

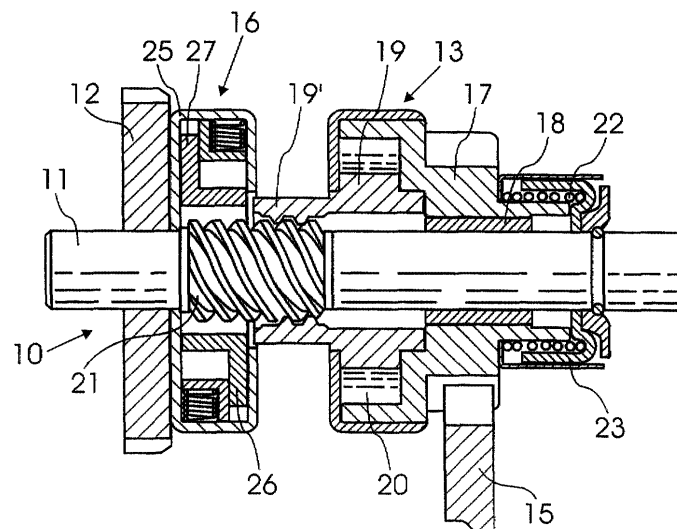

Fig. 2



European Patent Office

EUROPEAN SEARCH REPORT

Application Number  
EP 00 10 0643

DOCUMENTS CONSIDERED TO BE RELEVANT			
Category	Citation of document with indication, where appropriate, of relevant passages	Relevant to claim	CLASSIFICATION OF THE APPLICATION (Int.Cl.7)
D,A	EP 0 333 669 A (EFEL SPA) 20 September 1989 (1989-09-20) * abstract * * figures 1-5 *	1-14	F02N15/06
A	GB 567 440 A (BENDIX AVIAT CORP) 14 February 1945 (1945-02-14) * page 1, line 75 - page 2, line 2 * * figures 1-3 *	1	
D,A	US 4 325 265 A (WAKATSUKI GOROEI ET AL) 20 April 1982 (1982-04-20) * the whole document *	1	
			TECHNICAL FIELDS SEARCHED (Int.Cl.7)
			F02N
The present search report has been drawn up for all claims			
Place of search		Date of completion of the search	Examiner
THE HAGUE		20 June 2002	Röttger, K
CATEGORY OF CITED DOCUMENTS			
X : particularly relevant if taken alone Y : particularly relevant if combined with another document of the same category A : technological background O : non-written disclosure P : intermediate document		T : theory or principle underlying the invention E : earlier patent document, but published on, or after the filing date D : document cited in the application L : document cited for other reasons & : member of the same patent family, corresponding document	

EPO FORM 1503 03/82 (P04C01)

**ANNEX TO THE EUROPEAN SEARCH REPORT  
ON EUROPEAN PATENT APPLICATION NO.**

EP 00 10 0643

This annex lists the patent family members relating to the patent documents cited in the above-mentioned European search report. The members are as contained in the European Patent Office EDP file on  
The European Patent Office is in no way liable for these particulars which are merely given for the purpose of information.

20-06-2002

Patent document cited in search report		Publication date	Patent family member(s)	Publication date
EP 0333669	A	20-09-1989	IT 1219129 B	03-05-1990
			AT 71190 T	15-01-1992
			DE 68900626 D1	13-02-1992
			EP 0333669 A1	20-09-1989
			ES 2029137 T3	16-07-1992
			PT 90044 A , B	10-11-1989
			US 4924717 A	15-05-1990
-----				
GB 567440	A	14-02-1945	NONE	
-----				
US 4325265	A	20-04-1982	JP 1329703 C	30-07-1986
			JP 55117073 A	09-09-1980
			JP 60053785 B	27-11-1985
			DE 3007778 A1	11-09-1980
			FR 2450360 A1	26-09-1980
			GB 2080430 A , B	03-02-1982
-----				

EPO FORM P0459

For more details about this annex : see Official Journal of the European Patent Office, No. 12/82