

Nov. 26, 1935.

A. L. SPAFFORD

2,022,161

ACOUSTIC TILE

Filed Dec. 10, 1930

2 Sheets-Sheet 1

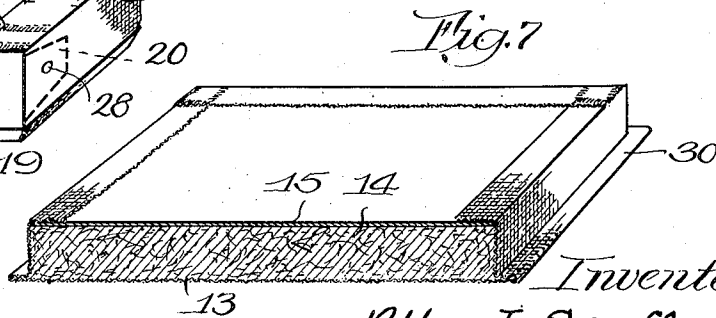
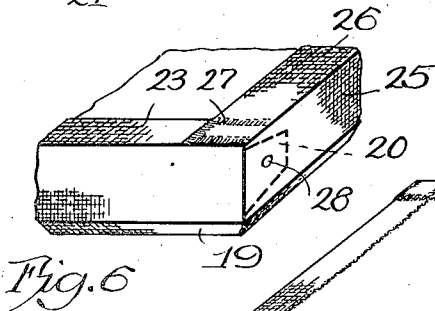
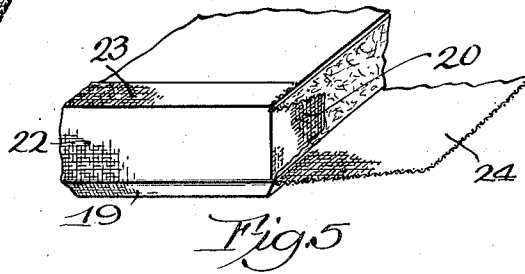
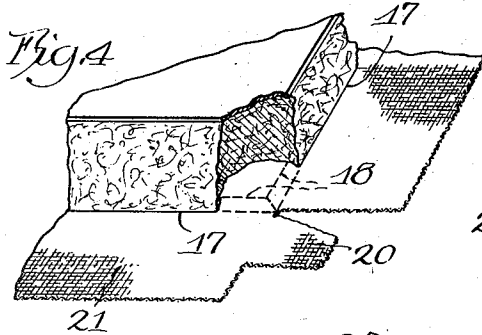
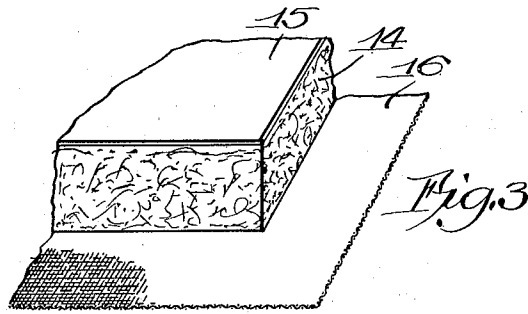
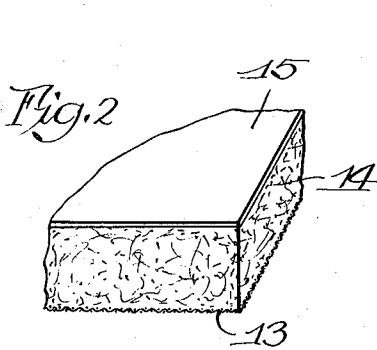
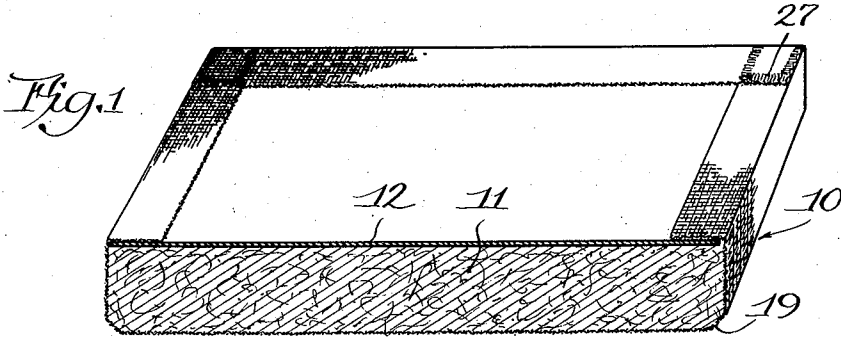

Inventor,
Allen I. Spafford
By W. Barrett Jones, Atty.

Nov. 26, 1935.

A. L. SPAFFORD

2,022,161

ACOUSTIC TILE

Filed Dec. 10, 1930

2 Sheets-Sheet 2

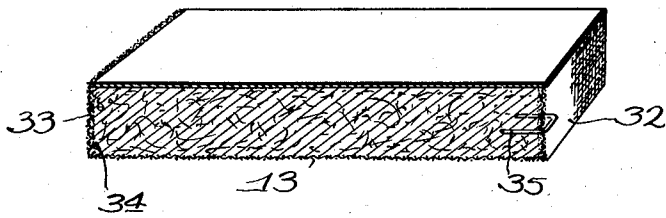

Fig. 8

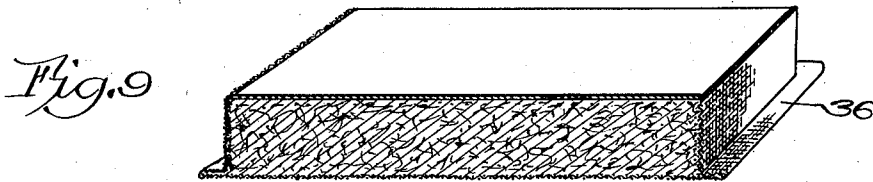

Fig. 9

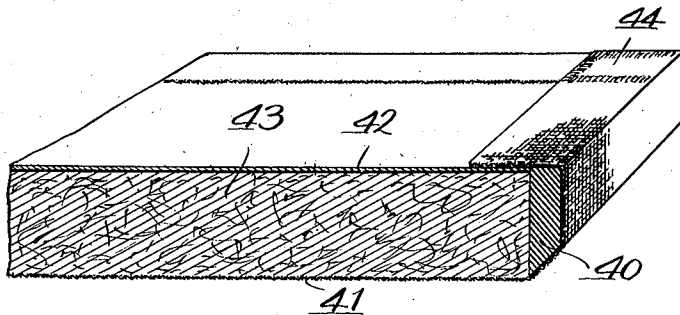

Fig. 10

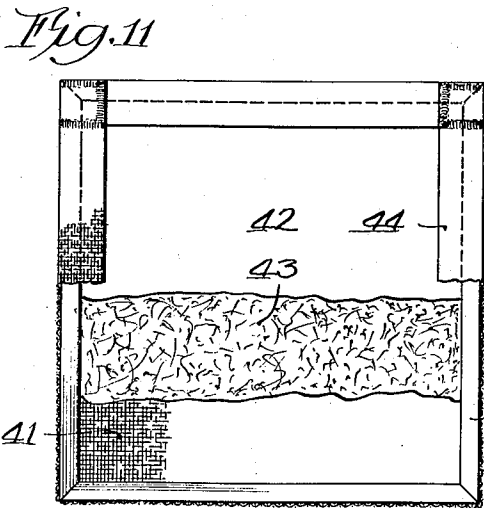

Fig. 11

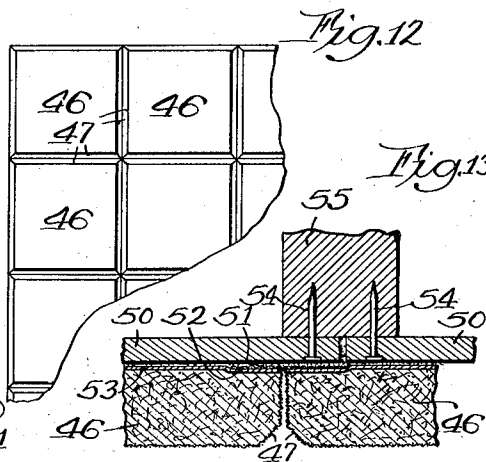

Fig. 12

Fig. 13

Inventor,
Allen L. Spafford,
By W. Bartlett Jones, Atty.

UNITED STATES PATENT OFFICE

2,022,161

ACOUSTIC TILE

Allen L. Spafford, Cloquet, Minn., assignor to The Wood Conversion Company, Cloquet, Minn., a corporation of Delaware

Application December 10, 1930, Serial No. 501,287

1 Claim. (Cl. 154—44)

The present invention relates to sound absorbing structures and acoustic material, having particular reference to a sound absorbing tile particularly useful in wall structures, including ceilings and side walls.

The art of sound proofing has developed to a considerable extent in recent years and numerous sound absorbing materials and structures are to be found on the market. They require considerable care and labor in installation to give a pleasing and artistic installation. Where corners, recesses, and irregular shaped areas are to be covered the materials need to be operated upon and arrangement of material must be carefully planned for appearance and effect.

The present invention aims to provide an acoustic tile, which may be made in small sized units, which is complete in itself, and which needs only to be applied by suitable means to form a sound absorbing wall, and which can be readily made in special shapes.

One object of the invention is to provide a unitary acoustic tile.

Another object is to provide an acoustic tile which has heat insulating properties and which may be installed in numbers to provide a heat insulating wall.

Still another object is to provide a box-like unit containing sound absorbent material which is light in weight, rigid, and easily adapted to being adhesively united to a support.

A particular object is the provision of a wire screen box with wire screen areas at the box top, which is the interior face of the unit, useful as a basis for anchoring an adhesive substance.

Various other objects and advantages of the invention will become apparent from the following description of several illustrative forms of the invention which are shown in the accompanying drawings and from the exemplary wall structures embodying such units.

Fig. 1 represents a rectangular sound absorbing tile with a portion cut away showing the interior construction in cross-section.

Fig. 2 represents a corner of a piece of continuous blanket which may be used as a basis for manufacture of the units.

Fig. 3 represents a corner of a rectangular piece of the blanket of Fig. 2 with a portion of the insulation mat cut away to provide a margin of wire screen base.

Fig. 4 represents a corner of the article of Fig. 3 showing operations on the screen preliminary to folding into a box form.

Fig. 5 represents one side of the box already formed.

Fig. 6 represents the complete formation at one corner of the box structure.

Fig. 7 is a view similar to Fig. 1 showing a modified construction of a unit having a crimp at the edge of the box structure.

Figs. 8 and 9 are views like Figs. 1 and 7 showing other modifications.

Fig. 10 is another form of the invention incorporating a rigid frame within the structure.

Fig. 11 is a fragmentary plan view of the form shown in Fig. 10 showing the components thereof.

Fig. 12 is a diagrammatic representation of a wall formed of the units of Figs. 1 or 10.

Fig. 13 is a cross-sectional view of a wall structure showing in detail the relation of the tile to a support.

Generally the invention comprises a unit body or block which has a perforated face behind which is a sound absorbent material. The structure is rigid and is capable of being supported from either face by numerous means. It may rest on supports, or it may be secured at the edges, or it may have its rear face adhesively united to a wall.

As sound absorbent material I prefer to use a wood fiber mat which may be made by a continuous process as described in Weiss U. S. Patent No. 1,336,403. The material of this type is generally known as "Balsam-Wool" and is useful as a heat insulator as well as a sound insulator and absorber. One of the advantages of using the Balsam-Wool lies in the process by which it is most readily made. This comprises dropping loose fibers onto a moving sheet, and spraying into the dropping fibers a liquid adhesive, whereby the fibers become adhesively united to the moving sheet and to each other in the form of a unitary porous fibrous mat of any desired thickness. Onto a finished mat a facing is adhesively applied. For heat insulation blankets two paper facings have been employed which are readily adapted to flex and pass from a supplying roll of such material over rolls in the machines used to manufacture such an insulation blanket.

To make a continuous length of sound absorbing material with the same machines, one sheet facing is made of perforated material which may be supplied from a roll and which will flex sufficiently for manufacturing purposes. Wire screen is the preferred material of this character, but it will be understood that suitably thin perforated sheet material, such as flat metal could

be used, or even a semi-rigid flexing non-metallic sheet which is or can be perforated to admit sound. One feature of the material is rigidly in small sizes and ability to be deformed without breaking to form a more rigid unit. Wire screen is by far the most suitable because it is highly perforated, semi-rigid, flexible, and tough within the degrees required for this invention. Its strands are individually flexible, and the screen sheet may be deformed without difficulty with a limited amount of expansion and compression within the sheet itself by displacement or stretching of the strands.

In making the units of the present invention I prefer to use as starting material a sheet of Balsam Wool mat between a wire screen layer and a sheet of paper as facing layers. However, it is to be understood that the invention is not limited to this material and to the method of using it which is more particularly described herein as the preferred method of practicing the invention.

Fig. 1 represents a piece of a tile which may be square or oblong. It has a wire mesh box-like containing form 10, an interior sound absorbing filler such as fiber 11 and a sheet backing such as paper 12.

From a sheet of starting material I cut a block or section, a corner of which is shown in Fig. 2. It has a flat screen facing 13, a fiber mat 14, and a facing such as paper 15. The size is determined by the size of the screen facing which is to be employed to make the desired containing form. A portion of the paper and fiber body is cut away peripherally, forming a margin 16 of exposed screen, a corner being shown in Fig. 3. The size of the remaining fiber section determines the approximate size of the unit. A unit which is one foot square and which has a one inch thickness of fiber is particularly useful.

The piece with marginal screen may then be operated upon to form the unit in various ways. One method is to push back the fiber mat at the lines 17 so that a tool, as in a die machine, may press down on the screen against a blank to deform it on the lines 17 and internally thereof on the lines 18 (shown dotted in Fig. 4) to define what becomes a narrow bevel face 19 shown in Fig. 1. In the same operation cuts may be made at the corners of the marginal screen 16 as indicated in Fig. 4, leaving a tongue 20. Two opposite edges of screen may be so formed, making four such tongues extending in parallel relation. Thereafter the two sides carrying the tongues, designated 21, are bent up and over the fibrous mat forming a screen side edge 22 and an extension of the side which provides a margin of screen backing 23. The tongue 20 may be bent around the corner. The remaining portions 24 of the projecting screen are likewise bent up and over forming screen sides 25 and extensions of screen facing 26 which overlie the extensions 23 at the corners of the unit.

The overlapping corners may be bound together, preferably by a U-shaped spot-weld 27 about edges of the contiguous portions. The tongue 20 may be spot-welded at 28 to the screen or edge face 25 if desired. This structure forms a rigid box-like container and a light-weight rigid flat practically inflexible unit.

A modified construction is shown in Fig. 7 in which a projecting crimp 30 is formed in the projecting screen rather than the bevel face 19 of Fig. 1. The tile units like Fig. 1 are adapted to be mounted side-by-side in block formation, edge

to edge, and the bevel faces give a neat and artistic effect at the junctions of adjacent units. In other forms the crimp 30 affords a ridge which may be used in certain methods of mounting and it permits a space to exist between adjacent units. Such a space may be desirable for numerous purposes.

By using the blanket sheet from a continuous forming machine, I have provided initially a body in which the screen is adhesively united to the sound deadening material. The adhesion to the screen and of fiber to fiber assures that the fiber mat will stay in place and that it will not sift out of the screen or become loosened therefrom. The mat is visible through the screen and a loose area or an area of the fiber raised from the wire appears as a dark spot in the unit. Consequently, the uniform adhesion of the mat to the screen presents a uniform appearance at the face of the unit.

It is not necessary that the mat and screen be united as herein described. A separate screen box-like form may be made, and a mat inserted therewith adhesive applied at the time of insertion, or thereafter through the face of the screen. In practice, beginning with the manufacture of the blanket, I may use a previously painted or decorated screen upon which fibers are matted, or I may apply paint to a unit when completed, and at that time make special designs. Paint applied to a completed unit by spraying may reinforce or provide an original adhesive for the screen and fibers therein. The adhesive may be omitted entirely but its presence is of a great benefit giving desired qualities to the unit.

Other forms may be provided. The bevel face and the crimp may be omitted and a perforated box or screen container 31 (Fig. 8) be employed without overturned portions. In Fig. 8 the screen sides 32 of the box extend to the top of the fibrous core 33. A sheet of paper or other material is used as a rear facing on the unit. In this form an adhesive 34 may be applied between the sides 32 and the core 33 which unites the core and screen in the absence of an adhesive at the face. Other means of union may be provided such as U-shaped pins 35 acting like hairpins on the well matted fibrous core.

Fig. 9 shows a structure like that of Fig. 8 with the provision of a crimped edge 36.

In Figs. 10 and 11 other means of securing rigidity or additional rigidity are shown. A rigid frame 40, as of wood may be used to house the sound absorbent material and to support and carry the screen. The screen facing 41 carries between it and the rear facing sheet 42, a sound absorbent material 43. The screen is carried around the frame and over the back as shown at 44 where it provides a good mesh work for anchoring the unit in a plaster or by a plaster or a glue or cement to a flat supporting surface.

All of the units here described are light in weight and slightly flexible. They have a yieldable rear facial area provided by the backing sheet particularly when it is paper. The sheet may be plain or creped paper or a water-proofed paper, such as one with asphalt between two layers. Creped paper facing is particularly advantageous as it provides a rough surface for anchoring the unit by a plaster, glue or cement, and it extends the roughness provided by turned over edges of screen or other perforated material which forms the box.

The units may be readily installed in a ceiling by merely cementing them in place. Cement may

be applied over the entire surface or only at portions thereof, as at the edges, where the perforated material is. The installation is easy and simple and requires little skill and equipment.

5 Fig. 12 represents a corner of a wall or ceiling structure in which units 46 like those of Fig. 1 are installed side by side, the bevelled edges 47 giving a pleasing effect.

10 Fig. 13 illustrates how the tile units may be cemented or glued to a wall surface. A wall material designated 50 may be a plaster surface, a wall board or other such material to which a glue or cement will adhere. The tile units 46 may be glued or cemented to the support as at 51.
 15 The cement 51 may cover both the wire mesh 52 and the paper backing 53 or one, or the other. The units may be secured to a wall board 50 prior to mounting of the latter in the wall structure. A wall board having units previously mounted thereon may be used as a ceiling or side-wall
 20 panel and be nailed to studding as shown by the nails 54 entering a stud 55.

The paper backing herein described acts as a
 25 sealing sheet for the otherwise porous unit, and such a structure makes the unit a heat insulator as well as a sound absorber. The tiles together may therefore be employed as the entire effective substance of a wall, providing heat insulation. A supporting lattice work or an open wall may be
 30 made which, however completely covers the areas of the joints, and the glue or cement employed over the wire screen parts on the rear of the tile co-operates with the paper backing to extend the seal from the backing sheets to the supports and back to the backing sheets, thus completely

sealing a wall structure of such units against drafts. The sealing-off sheet at the rear of the unit preventing the circulation of air is effective for preventing the formation of "lath marks" when the unit is next to laths or the like.

5 The units may be readily formed with a fire-proof structure. The screen of wire is of course fire-proof. The fibrous core might be made of asbestos, but this is not necessary since the wood fibers may be readily fire-proofed. Asbestos paper backings may be used. However, this is not
 10 necessary, as a sheet of Kraft paper with a sodium silicate used as adhesive therefor effects fire-proofing of the paper. It may be used either within the unit for uniting the paper to the
 15 fiber or as an adhesive on the outer side of the unit to mount it. The asphalted paper, in single layers, double layers, plain or creped, may be treated with sodium silicate and the material rendered fire-proof. The silicate permeates the
 20 asphalt as well as the paper.

It is to be understood that the present invention is not to be considered as limited to the exact disclosures made herein, and that numerous
 25 variations and modifications of structure and use are herein contemplated, as will appear from the scope of the appended claim.

I claim:

30 A sound absorbing tile-like unit comprising a wire screen box having a projecting extension of screen material at the junction of the sides with the bottom of the box, and sound absorbing material secured inside said box.

ALLEN L. SPAFFORD.