

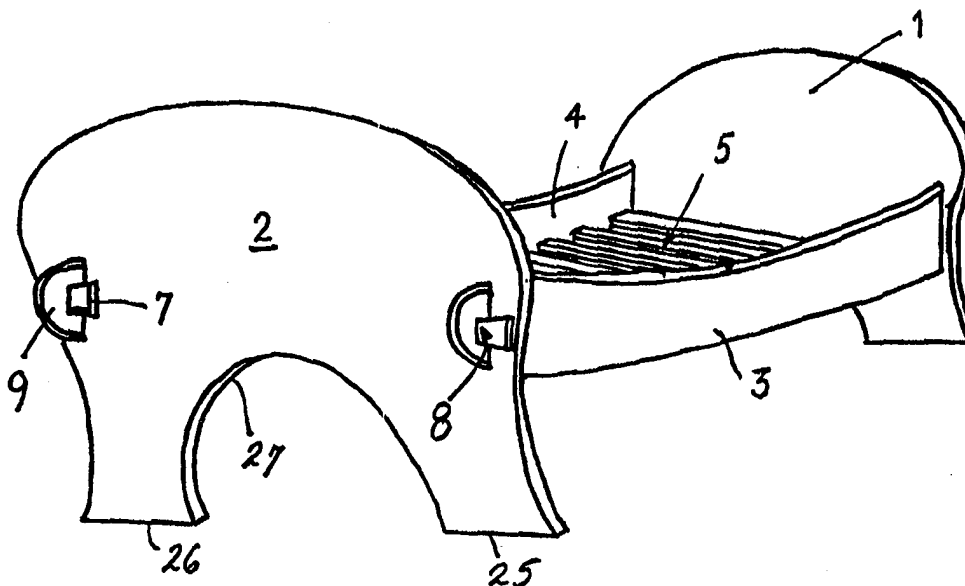

INTERNATIONAL APPLICATION PUBLISHED UNDER THE PATENT COOPERATION TREATY (PCT)

<p>(51) International Patent Classification ⁶ : A47C 19/02, 19/00</p>	A1	<p>(11) International Publication Number: WO 98/16143</p> <p>(43) International Publication Date: 23 April 1998 (23.04.98)</p>
<p>(21) International Application Number: PCT/GB97/02647</p> <p>(22) International Filing Date: 26 September 1997 (26.09.97)</p> <p>(30) Priority Data: 9621251.9 11 October 1996 (11.10.96) GB</p> <p>(71) Applicant (for all designated States except US): THE PILGRIM BED LIMITED [GB/GB]; 7 Riverside Avenue, East Molesey, Surrey KT8 0AE (GB).</p> <p>(72) Inventor; and (75) Inventor/Applicant (for US only): NOCKLES, Helen, Louise [US/GB]; 7 Riverside Avenue, East Molesey, Surrey KT8 0AE (GB).</p> <p>(74) Agent: BURREINGTON, Alan, Graham, Headford; Alan Burrington & Associates, 4 Burney Close, Great Bookham, Leatherhead, Surrey KT22 9HW (GB).</p>		<p>(81) Designated States: CA, HU, US, European patent (AT, BE, CH, DE, DK, ES, FI, FR, GB, GR, IE, IT, LU, MC, NL, PT, SE).</p> <p>Published <i>With international search report. Before the expiration of the time limit for amending the claims and to be republished in the event of the receipt of amendments.</i></p>

(54) Title: IMPROVEMENTS IN OR RELATING TO ALLERGEN-AVOIDANCE BEDS



(57) Abstract

The wooden bed frame shown in the figure is designed to reduce the effect of the House Dust Mite upon a sleeper allergic to such Mites. The bed incorporates a number of features each of which contribute to reduce asthma attacks for sleepers sensitive to the House Dust Mite. The bed frame includes a footboard (2) and a headboard (1) outwardly inclined at an angle of between 5° and 25°, preferably at 15°, to the vertical. The headboard (1) and footboard (2), both extend beyond the width of an air mattress (not shown) lying between stringers (3 and 4) to ensure good circumjacent air circulation even when located against a wall. The mattress is supported on slats (6) mounted between the stringers (3 and 4). In use the air mattress may be covered by a quilted cotton material that is readily washed and dried so that it does not act as a natural host for House Dust Mites. The pillow (not shown) is enveloped in a zipped non-woven micro-porous pillowcase that is designed to exclude House Dust Mites from entering the pillow.

FOR THE PURPOSES OF INFORMATION ONLY

Codes used to identify States party to the PCT on the front pages of pamphlets publishing international applications under the PCT.

AL	Albania	ES	Spain	LS	Lesotho	SI	Slovenia
AM	Armenia	FI	Finland	LT	Lithuania	SK	Slovakia
AT	Austria	FR	France	LU	Luxembourg	SN	Senegal
AU	Australia	GA	Gabon	LV	Latvia	SZ	Swaziland
AZ	Azerbaijan	GB	United Kingdom	MC	Monaco	TD	Chad
BA	Bosnia and Herzegovina	GE	Georgia	MD	Republic of Moldova	TG	Togo
BB	Barbados	GH	Ghana	MG	Madagascar	TJ	Tajikistan
BE	Belgium	GN	Guinea	MK	The former Yugoslav Republic of Macedonia	TM	Turkmenistan
BF	Burkina Faso	GR	Greece	ML	Mali	TR	Turkey
BG	Bulgaria	HU	Hungary	MN	Mongolia	TT	Trinidad and Tobago
BJ	Benin	IE	Ireland	MR	Mauritania	UA	Ukraine
BR	Brazil	IL	Israel	MW	Malawi	UG	Uganda
BY	Belarus	IS	Iceland	MX	Mexico	US	United States of America
CA	Canada	IT	Italy	NE	Niger	UZ	Uzbekistan
CF	Central African Republic	JP	Japan	NL	Netherlands	VN	Viet Nam
CG	Congo	KE	Kenya	NO	Norway	YU	Yugoslavia
CH	Switzerland	KG	Kyrgyzstan	NZ	New Zealand	ZW	Zimbabwe
CI	Côte d'Ivoire	KP	Democratic People's Republic of Korea	PL	Poland		
CM	Cameroon	KR	Republic of Korea	PT	Portugal		
CN	China	KZ	Kazakstan	RO	Romania		
CU	Cuba	LC	Saint Lucia	RU	Russian Federation		
CZ	Czech Republic	LI	Liechtenstein	SD	Sudan		
DE	Germany	LK	Sri Lanka	SE	Sweden		
DK	Denmark	LR	Liberia	SG	Singapore		
EE	Estonia						

TITLE

Improvements in or relating to allergen-avoidance beds.

THE INVENTION

The invention relates to beds particularly for asthma sufferers sensitive to the House Dust Mite. The bed is designed to create an environment that reduces a trigger for asthma attacks, and to remind a user that: (i) good air circulation; (ii) regularly washed cotton material adjacent to the user; (iii) the inter positioning of a non-woven micro-porous membrane between the user and the natural scavenger, the House Dust Mite; and, (iv) a readily cleaned mattress, all contribute to an allergen-free sleeping environment.

BACKGROUND TO THE INVENTION

The droppings of House Dust Mites (*Dermatophagoides pteronyssinus*), translated from the Latin as: "skin-eater on a feather", are a known major cause of asthma symptoms and the cause of sleepless nights for asthma sufferers sensitive to the House Dust Mite. The Mites colonise many Household items, including mattresses and bedding. These Mites need damp and

dark conditions. The Mites live on skin scales and produce faeces pellets with a size of 10 to 20 microns. The metabolism of House Dust Mites can only digest the human skin scales, which are constantly shed by everybody, after they have been encrusted with a fungus that derives from mould found in damp dark conditions. Therefore, by maintaining dry clean bedding the fungus cannot grow on the skin scales thus denying the House Dust Mite of its major source of food.

Depending upon the size of person, a human being can perspire up to about one litre of fluid each night. This provides the source of liquid for the mould to develop in bedding. The dark warm conditions of a bed also encourages the fungus to propagate on discarded skin scales trapped within the bedding.

It has been found that geographical distribution of the House Dust Mite which cause an allergic reaction in some asthma sufferers occurs mainly in countries lying in two belts lying above the tropic of Capricorn and below the tropic of Cancer.

According to an article on 26 May 1997 in Time and Newsweek, entitled "The scary spread of Asthma" it cites a 61% increase in asthma since the early 1980's, however, deaths from asthma peaked in 1989 and have since shown a steady decline of 6%.

A study sponsored by the UK National Asthma Council (now the National Asthma Campaign) in 1982 carried out by a team led by Dr. Thomas Platts-Mills concluded in a report published in The Lancet of 25 September 1982 that: "Avoidance of important allergens seems not only to result in clinical remission but in many cases there was a reduction of bronchial hypersensitivity."

The findings indicate that the major cause of asthma is from "indoor" air. "Outdoor" air pollution such as from vehicles is a lesser cause of asthma symptoms but considerable efforts are being made currently to reduce the emission from vehicles. This is expected to have little effect upon the incidence of asthma sufferers. Therefore the problem of asthma requires a solution to improve the quality of "indoor" air, particularly pollution caused by House Dust Mites.

The growing asthma problem in people sensitive to the House Dust Mite can be tackled by breaking into the chain leading to the distribution of allergens from House Dust Mites. Each of the following four actions help to break the chain:

- (i) ensuring good air flow around the bed;
- (ii) eliminating access to the mattress's internal spaces;
- (iii) providing readily washable bedding;

(iv) providing a pillow-slip inter-liner which seeks to prevent House Dust Mites and shed skin scales from entering the filling material of the pillow.

Additionally, the bedding should be regularly washed and aired.

The invention helps to facilitate the above four actions by:

- (i) providing a bed that is held away from adjacent walls;
- (ii) providing an air mattress on a slatted base;
- (iii) utilising cotton bedding for covering the mattress to absorb perspiration and skin scales;
- (iv) providing a non-woven micro-porous cotton pillow slip in which the openable side is sealed by a fine zip fastener.

PRIOR ART

It is known to provide beds with headboards that are wider than the width of the mattress or bed base. A substantially S-contoured headboard and similarly contoured footboard is known on a bed generally called a "sleigh bed". It is also known to provide beds with buffers that displace the headboard or footboard from an adjacent wall. Air-filled mattresses, cotton covering materials and cotton padding are also well known.

NOVEL ASPECTS OF THE PRESENT INVENTION

The present invention utilises a combination of features that have been found to substantially lessen asthma attacks in people sensitive to the House Dust Mite. A bed according to the present invention has a headboard and footboard that are inclined outward and extend laterally beyond the width of a support means for a mattress.

STATEMENT OF INVENTION

According to the present invention there is provided an allergen-avoidance bed comprising two end boards forming a headboard and a footboard, a pair of stringers for connecting the headboard to the footboard and a mattress base support for supporting an air-mattress, wherein, in use, at least one of the end boards is substantially planar and inclined outwardly from the bed at a first angle between 5° and 25° to the vertical.

Preferably the other end board is also planar and inclined outwardly from the bed at a second angle.

The first and second angles are preferably equal, and substantially at 15° , and the means for supporting the mattress is a series of parallel wooden slats mounted on two rubber coated

fabric belts extending between a beam adjacent the headboard and a beam adjacent the footboard.

Both of the substantially identical plank-like stringers are mounted in parallel between the headboard and the footboard. The inside face of both stringers is provided with a rail on which the ends of the slats rest.

The stringers may be smoothly shaped along their length so that the depth of the stringers are greater at their ends than at their centre. The shaping may be achieved by making the upper edge to be curved at a lesser radius than the curvature of the lower edge.

The stringers may be provided with tongues arranged to pass through co-operating slots in the headboard and footboard and each held in place by a wedge engaging a hole in the portion of the tongue which in use protrudes through the footboard and headboard. Alternatively, the stringers may be secured to the headboard and footboard by brackets, screws, glue or other securing means.

The bed may be flat-packed. The pack may contain an air-mattress, a cotton covered quilt filled with padding consisting of

cotton or easily washed and dried synthetic material. A cover for a pillow may also be included in the pack. Preferably the cover is made from a non-woven micro-porous fabric that prevents substantially all skin scales from passing therethrough.

The pillow cover is preferably closed on one side by a fine zip fastening. If a pillow is included in the pack it is preferably filled with an easily washed and dried synthetic material such as crimped Terelene (RTM), known types of hollow fibre material.

The bed frame is preferably constructed from wood that has rounded corners and is sealed with a wax finish or a clear varnish such as a non-allergenic paint like polyurethane.

DESCRIPTION OF THE DRAWINGS

The invention will now be described by way of example with reference to the accompanying diagrammatic drawings in which:

FIGURE 1 shows a perspective view of a bed frame according to the invention;

FIGURE 2 shows the bed frame in plan view in place in the corner of a room;

FIGURE 3 shows a cross section of the bed frame on the line A-A of figure 2; and,

FIGURES 4a to 4d illustrate the components of the bed frame before assembly.

Referring to Figures 1 and 2, the bed frame is made from wood and consists of two end boards forming a headboard 1 and a footboard 2 connected by two plank-like stringers 3 and 4 that support a bed base 5 formed by a series of parallel slats 6. The stringers 3 and 4 are held in place by four wedges 7 (shown in Figure 1) which co-operate with holes 8 in tongues 9 at the ends of the stringers 3 and 4. In use the tongues 9 pass through slots 10 (as shown in Figure 4a) in the headboard 1 and footboard 2. The slats 6 of the bed base 5 are mounted on two rubberised fabric bands 11 and 12 secured between two beams 13 and 14 forming the end slats of the bed base 5 adjacent the headboard 1 and footboard 2 respectively.

Figure 2 shows the assembled components of the bed frame that may be flat-packed for transportation. The separate components are shown in Figure 4. The flat pack may include other bed components such as an air-mattress 15 (not shown) and a cotton quilted mattress cover 16 (also not shown). A pillow (not shown) and a non-woven micro-porous cotton pillowcase (not shown) may also be included in the flat pack.

The pillowcase is tightly seamed on three sides closed at one end by a fine in-laid zip fastener. The pillow is filled with non-allergenic material such as crimped Terelene (RTM) or hollow fibre material. Such pillowcases and pillows are washable to ensure that any Dust Mites cannot thrive thereon.

As shown in Figure 2 the bed frame may be located in the corner of a room, illustrated by walls 17 and 18. It can be seen from Figure 2 that the top extremity 19 of the headboard 1 abuts the wall 17 and that protruding extremities 20 and 21 on the headboard 1 and footboard 2 respectively abut the wall 18. The headboard 1 is contoured with a convex upper edge 22 and concave sides 23 and 24. As shown in Figure 1 feet 25 and 26 are provided at the bottom of the footboard 2 by an arch 27. The headboard 1 is similarly contoured. The extremities 19, 20 and 21 ensure that the mattress 15 which in use lies on the bed base 5 between the stringers 3 and 4 is held away from the wall so that air may circulate between the mattress 15 and the walls 17 and 18. The spacing between the slats 6 allow the lower side of the air filled mattress 15 to be well aired. The spacing between the slats 6 also allows skin scales to drop through the bed frame onto the floor.

The headboard 1 is contoured so that the extremities 19 and 20 and the corresponding extremity 21 on the footboard 2 make point contact with the walls 17 and 18. The headboard 1 and footboard 2 are formed from a planar block of wood. The end boards 1 and 2 could have straight sides and a straight top but this format would create a line contact with the walls and hence reduce the free airflow around the bed. The curved top of the end boards 1 makes a point contact with the wall 17 because it is inclined to the vertical.

Referring now to Figure 3 it can be seen that the headboard 1 and footboard 2 are inclined outward from the bed. It has been found from trials that the angle H of inclination of the headboard 1 to the vertical may lie between 5° and 25°. The footboard 2 is inclined to the vertical at an angle F that is preferably the same as angle H. It will be appreciated that the height and shape of the headboard 1 and the footboard 2 do not need to be identical but aesthetically the appearance is improved if the bed is symmetrical. It will also be appreciated that the inherent strength of the bed frame is improved if the bed is symmetrical from side-to-side and from end-to-end. The end boards 1 and 2 are preferably inclined to the vertical at 15°.

The stringers 3 and 4 are contoured so that they are deeper at their extremities where they butt against the end boards 1 and 2 than they are in their centre. This enables a sleeper to get into and out of the bed more easily. This contouring is achieved by curving the upper edge of the stringers with a lesser radius of curvature than the lower edge. In one embodiment of the bed the upper edge has a radius of 5.6 metres and the lower edge has a radius of 13.3 metres. The depth of the stringers at their centre is 0.145 metres and the depth at their ends is 0.2 metres.

The design of the bed enables air to circulate around the bed. The bedding material consists of easily washed and dried material to prevent the infestation of the House Dust Mite.

As shown in Figures 4 the components of the bed can be flat-packed for ease of storage, transport and sale. The basic components for the flat pack consist of: the end boards 1 and 2; the stringers 3 and 4; the mattress support base 5; and, fixing means such as wedges 7 for connecting the stringers between the end boards 1 and 2.

The flat pack may also include allergen-avoidance bedding such as: an air mattress 15; a cotton covered quilt 16; and, a cotton non-woven micro-porous pillow cover.

Once the bed has been assembled the inflated air mattress 15 is placed on the support base 5. The mattress 15 is covered by the washable cotton quilted covering 16, and a pillow is zipped into the non-woven micro-porous cotton pillowcase. A readily cleanable duvet completes the allergen-free bed ready for use.

The construction of bed is intended to remind a user sensitive to the House Dust Mite that it is important to maintain a good air flow about the bed and that clean dry bedding is essential. The House Dust Mite cannot live for more than a few hours in sunlight. Therefore it is preferable to expose the bedding to sunlight whenever possible.

It will be appreciated that the described embodiment of the invention is provided by way of example and the bed or components thereof may be made from other material than wood. Other variants are possible within the scope of the invention so as to provide good air flow around an allergen-free bed environment.

CLAIMS

1. An allergen-avoidance bed comprising two end boards forming a headboard and a footboard, a pair of stringers for connecting the headboard to the footboard and a mattress base support for supporting an air-mattress, wherein, in use, one of the end boards is substantially planar and inclined outwardly from the bed at a first angle between 5° and 25° to the vertical.
2. A bed as claimed in claim 1 in which the end board is also planar and inclined outwardly from the bed at a second angle.
3. A bed as claimed in any preceding claim in which the first and second angles are equal.
4. A bed as claimed in any preceding claim in which the means for supporting the mattress is a series of parallel wooden slats mounted on two belts, which in use extend between a beam adjacent the headboard and a beam adjacent the footboard.

5. A bed as claimed in any preceding claim in which both stringers are substantially identical plank-like members that are mounted in parallel between the headboard and the footboard.

6. A bed as claimed in any preceding claim in which the inside face of both stringers is provided with a rail on which the mattress base support rests.

7. A bed as claimed in any preceding claim in which the stringers are smoothly shaped along their length so that the depth of the stringers are greater at their ends than at their centre.

8. A bed as claimed in claim 7 in which the shaping is provided by making the upper edge curved at a lesser radius than the curvature of the lower edge.

9. A bed as claimed in any preceding claim in which the stringers are secured to the headboard and footboard.

10. A bed as claimed in any preceding claim in which the stringers are provided with tongues arranged to pass through co-operating slots in the headboard and footboard and each held in

place by a wedge engaging a hole in the portion of the tongue which in use protrudes through the head board and footboard.

11. A bed as claimed in any preceding claim in which the bed is flat-packed.

12. A flat packed bed as claimed in claim 11 in which the pack contains an air-mattress, a quilt filled with padding consisting of easily washed and dried material.

13. A bed pack as claimed in claim 11 in which the pack includes a cover for a pillow.

14. A bed pack as claimed in claim 13 in which the pillow cover is closed on one side by a fine zip fastening.

15. A bed pack as claimed in any of claims 11 to 14 in which the quilt consists of cotton material and the cover for the pillow consists of a non-woven micro-porous synthetic material.

16. A bed pack as claimed in claim 15 in which the quilt cover absorbs skin scales shed by a sleeper in the bed and the pillow cover consisting of a non-woven micro-porous synthetic material

that prevents substantially all skin scales and House Dust Mites from passing therethrough.

17. A bed frame as claimed in any preceding claim which is constructed from wood that has rounded corners and is sealed with a non-allergenic surface treatment.

18. A bed as claimed in any preceding claim substantially as hereinbefore described with reference to the accompanying drawings.

Fig. 1

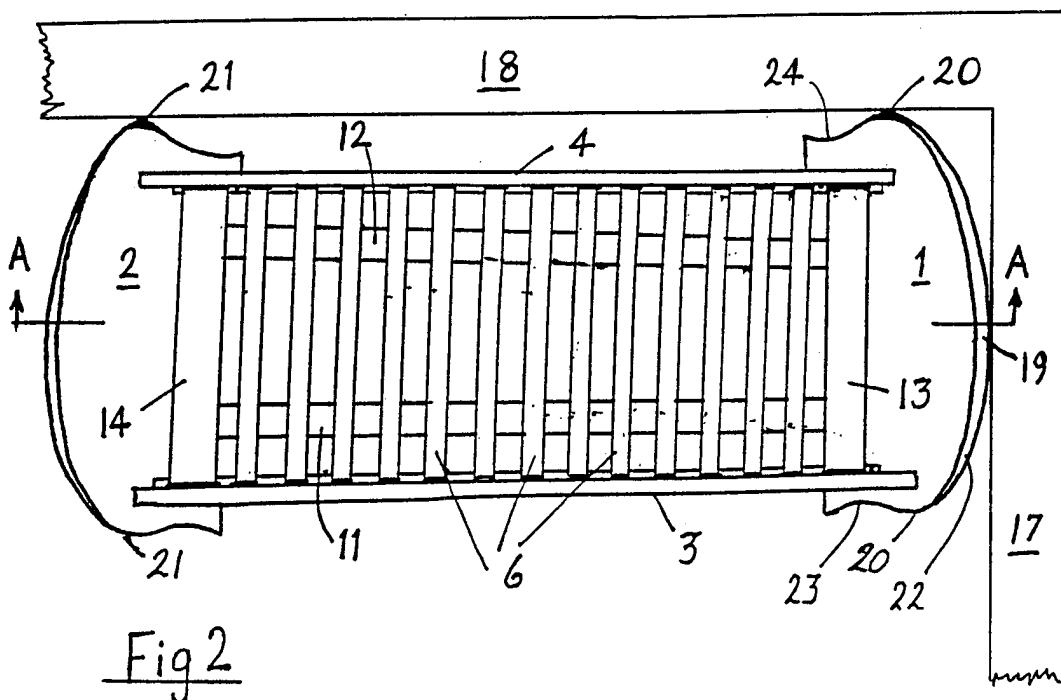
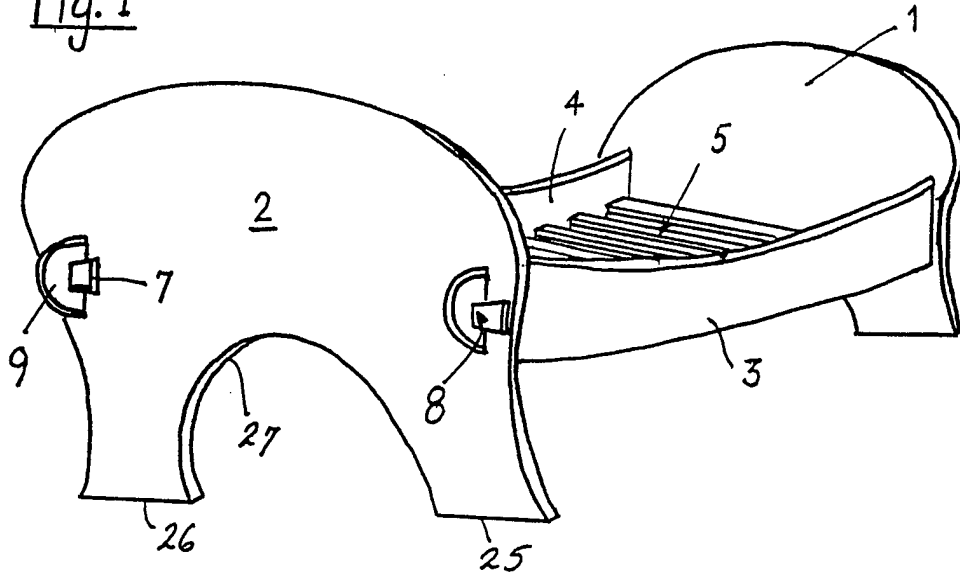

Fig 2

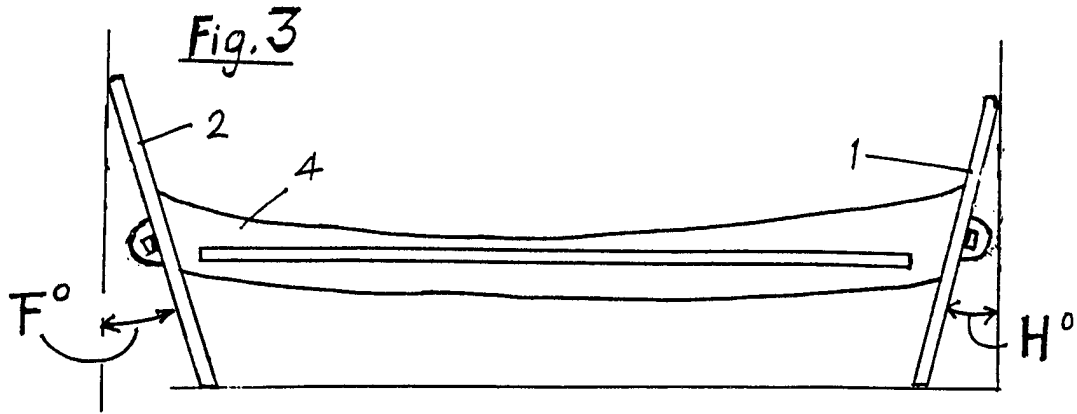
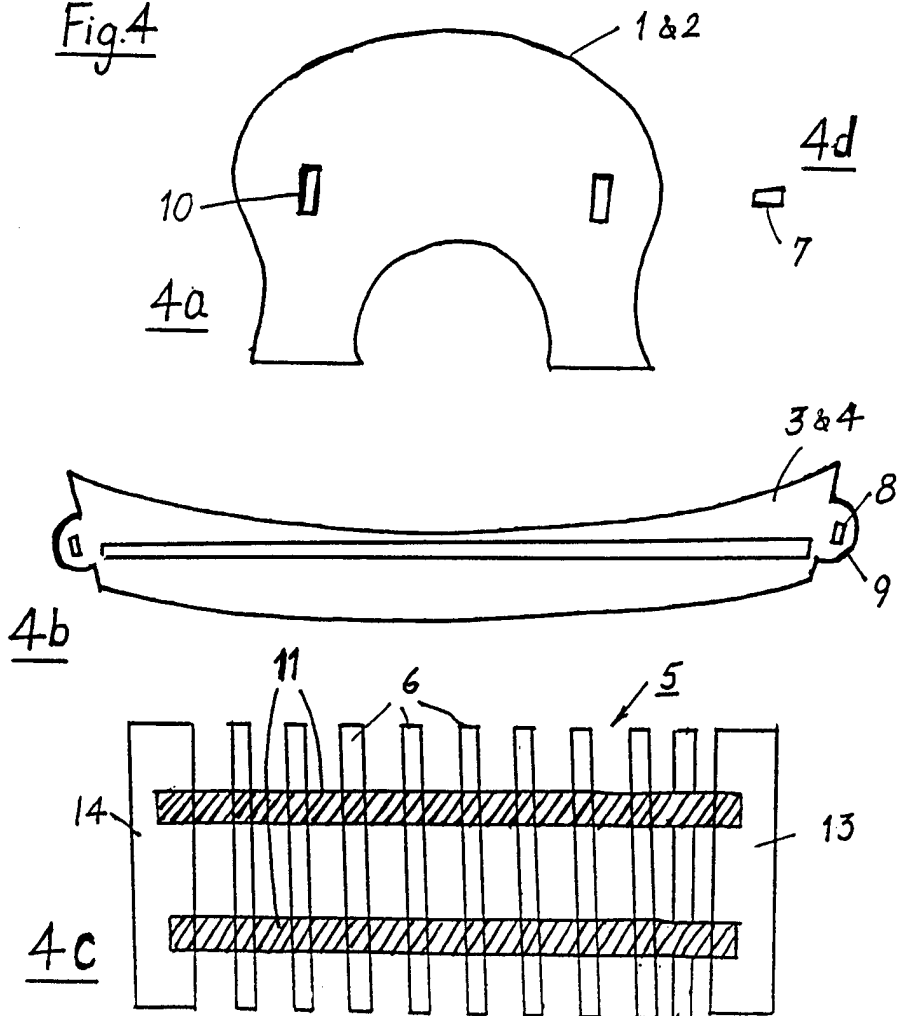

Fig. 4



INTERNATIONAL SEARCH REPORT

International Application No

PCT/GB 97/02647

A. CLASSIFICATION OF SUBJECT MATTER
 IPC 6 A47C19/02 A47C19/00

According to International Patent Classification (IPC) or to both national classification and IPC

B. FIELDS SEARCHED

Minimum documentation searched (classification system followed by classification symbols)

IPC 6 A47C A47D

Documentation searched other than minimum documentation to the extent that such documents are included in the fields searched

Electronic data base consulted during the international search (name of data base and, where practical, search terms used)

C. DOCUMENTS CONSIDERED TO BE RELEVANT

Category	Citation of document, with indication, where appropriate, of the relevant passages	Relevant to claim No.
A	DE 86 33 219 U (TEXTILWERK PETER LONSBURG) 12 February 1987 see the whole document -----	1-7, 9-11, 17, 18
A	FR 2 222 977 A (TURCK SIN) 25 October 1974 -----	
A	CH 667 196 A (DVORAK) 30 September 1988 -----	

Further documents are listed in the continuation of box C.

Patent family members are listed in annex.

Special categories of cited documents :

- "A" document defining the general state of the art which is not considered to be of particular relevance
- "E" earlier document but published on or after the international filing date
- "L" document which may throw doubts on priority claim(s) or which is cited to establish the publication date of another citation or other special reason (as specified)
- "O" document referring to an oral disclosure, use, exhibition or other means
- "P" document published prior to the international filing date but later than the priority date claimed

- "T" later document published after the international filing date or priority date and not in conflict with the application but cited to understand the principle or theory underlying the invention
- "X" document of particular relevance; the claimed invention cannot be considered novel or cannot be considered to involve an inventive step when the document is taken alone
- "Y" document of particular relevance; the claimed invention cannot be considered to involve an inventive step when the document is combined with one or more other such documents, such combination being obvious to a person skilled in the art.
- "&" document member of the same patent family

Date of the actual completion of the international search

23 January 1998

Date of mailing of the international search report

10/02/1998

Name and mailing address of the ISA

European Patent Office, P.B. 5818 Patentlaan 2
 NL - 2280 HV Rijswijk
 Tel. (+31-70) 340-2040, Tx. 31 651 epo nl,
 Fax: (+31-70) 340-3016

Authorized officer

VandeVondele, J

INTERNATIONAL SEARCH REPORT

Information on patent family members

International Application No

PCT/GB 97/02647

Patent document cited in search report	Publication date	Patent family member(s)	Publication date
DE 8633219 U	12-02-87	NONE	
FR 2222977 A	25-10-74	BE 812727 A	15-07-74
CH 667196 A	30-09-88	NONE	