



- (51) International Patent Classification:
B25B 15/00 (2006.01) *F16B 35/04* (2006.01)
F16B 23/00 (2006.01) *F16B 35/06* (2006.01)
- (21) International Application Number:
PCT/US2016/022927
- (22) International Filing Date:
17 March 2016 (17.03.2016)
- (25) Filing Language: English
- (26) Publication Language: English
- (30) Priority Data:
62/135,390 19 March 2015 (19.03.2015) US
- (71) Applicant: ACUMENT INTELLECTUAL PROPERTIES, LLC [US/US]; 6125 Eighteen Mile Road, Sterling Heights, MI 48314 (US).
- (72) Inventor: GOSS, David, C.; 1317 Harlem Boulevard, Rockford, IL 61103 (US).

- (74) Agent: FOLEY, James, R.; Clark Hill PLC, 150 North Michigan Avenue, Suite 2700, Chicago, IL 60601 (US).
- (81) Designated States (unless otherwise indicated, for every kind of national protection available): AE, AG, AL, AM, AO, AT, AU, AZ, BA, BB, BG, BH, BN, BR, BW, BY, BZ, CA, CH, CL, CN, CO, CR, CU, CZ, DE, DK, DM, DO, DZ, EC, EE, EG, ES, FI, GB, GD, GE, GH, GM, GT, HN, HR, HU, ID, IL, IN, IR, IS, JP, KE, KG, KN, KP, KR, KZ, LA, LC, LK, LR, LS, LU, LY, MA, MD, ME, MG, MK, MN, MW, MX, MY, MZ, NA, NG, NI, NO, NZ, OM, PA, PE, PG, PH, PL, PT, QA, RO, RS, RU, RW, SA, SC, SD, SE, SG, SK, SL, SM, ST, SV, SY, TH, TJ, TM, TN, TR, TT, TZ, UA, UG, US, UZ, VC, VN, ZA, ZM, ZW.
- (84) Designated States (unless otherwise indicated, for every kind of regional protection available): ARIPO (BW, GH, GM, KE, LR, LS, MW, MZ, NA, RW, SD, SL, ST, SZ, TZ, UG, ZM, ZW), Eurasian (AM, AZ, BY, KG, KZ, RU, TJ, TM), European (AL, AT, BE, BG, CH, CY, CZ, DE, DK, EE, ES, FI, FR, GB, GR, HR, HU, IE, IS, IT, LT, LU, LV, MC, MK, MT, NL, NO, PL, PT, RO, RS, SE, SI, SK,

[Continued on next page]

(54) Title: DRIVE SYSTEM WITH FULL SURFACE DRIVE CONTACT

FIG. 1

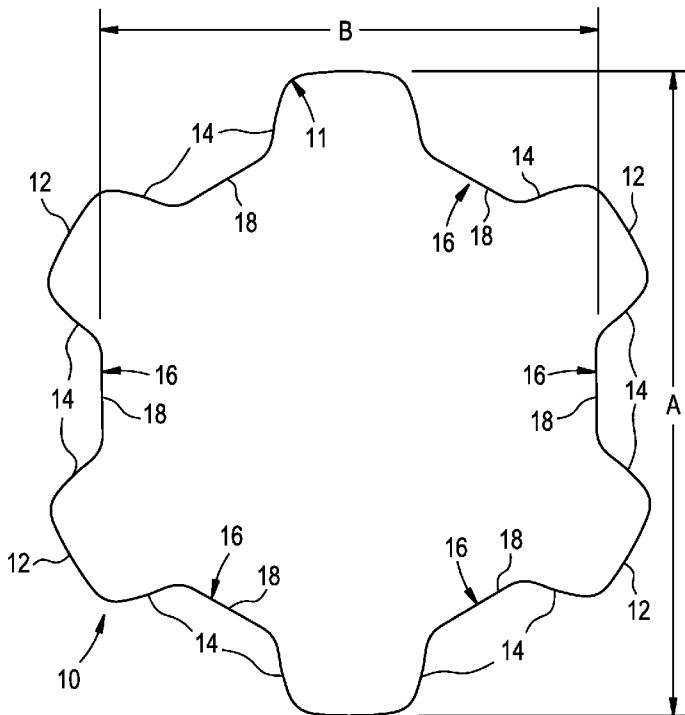

(57) Abstract: A drive system with full surface drive contact. The drive system tends to maximize the surface contact pattern or area at typical bit-recess reaction (drive) torque values, thereby tending to minimize bit-recess surface contact stresses, coating damage, recess ream and premature bit fatigue failure. An object of an embodiment of the present invention is to provide a drive system with full surface drive contact. An object of an embodiment of the present invention is to provide a drive system that tends to maximize the surface contact pattern or area at typical bit-recess reaction (drive) torque values, thereby tending to minimize bit-recess surface contact stresses, coating damage, recess ream and premature bit fatigue failure.

WO 2016/149526 A1

SM, TR), OAPI (BF, BJ, CF, CG, CI, CM, GA, GN, GQ, GW, KM, ML, MR, NE, SN, TD, TG). **Published:**

— with international search report (Art. 21(3))

DRIVE SYSTEM WITH FULL SURFACE DRIVE CONTACT

Inventor

David C. Goss

Related Application (Priority Claim)

This application claims the benefit of United States Provisional Application Serial No. 62/135,390, filed March 19, 2015, which is hereby incorporated herein by reference in its entirety.

Background

The present invention generally relates to drive systems, such as drive systems involving a bit and a fastener, as well as a punch for forming a recess in the fastener.

5 Typical fastener drive system designs or geometries result in various surface contact patterns between the drive tool (i.e., bit) and fastener drive feature (i.e., recess). For example, some drive system geometries result in a “point” contact surface pattern, meaning that when the bit is rotated to initial contact with the recess (with near zero reaction torque), it contacts the recess at a point (or a plurality of points around the recess).

10 Other drive system geometries result in a “line” contact surface pattern, meaning that when the bit is rotated to initial contact, it contacts the recess at a plurality of lines. To place the bit inside of the recess in the fastener, there has to be some sort of gap between the bit and recess. As the bit is rotated, the gap between the bit and recess narrows until there is line contact with the sidewalls of the recess. Both point and line contact systems generate high stresses throughout the drive system and can also add to bit failure.

15 Still other drive system geometries result in an “area” contact surface pattern from the end of the bit to the top of the recess. Generally, an “area” contact surface pattern is more beneficial than a “line” contact surface pattern, and a “line” contact surface pattern is more beneficial than a “point” contact surface pattern.

However, even with regard to an “area” contact surface pattern, as bit-recess reaction torque (i.e., drive torque) increases, the drive bit geometry is elastically distorted (i.e., twisted and compressed), as well as the recess geometry (i.e., compressed), causing the bit-recess contact surface pattern to change and shift from the end of the bit toward the top of the recess. As the
5 reaction torque increases, the surface contact pattern area tends to decrease, thus further increasing bit-recess contact stresses. The increased contact stresses at the top of the recess may damage the fastener finish (i.e., coating), and may lead to recess failure (ream-out). The increased contact stresses on the bit (and twisting) may cause premature wear, recess failure and fatigue failure.

10

Summary

An object of an embodiment of the present invention is to provide a drive system with full surface drive contact.

An object of an embodiment of the present invention is to provide a drive system that
5 tends to maximize the surface contact pattern or area at typical bit-recess reaction (drive) torque values, thereby tending to minimize bit-recess surface contact stresses, coating damage, recess ream and premature bit fatigue failure.

Briefly, an embodiment of the present invention provides a drive system which includes a fastener, wherein the fastener comprises drive surfaces which are formed of polygon involutes
10 formed of one or more arcs, or is a single arc construction. With regard to the arcs that define the drive surfaces, preferably each arc has a constant radius (i.e., is a segment of a circle).

Another embodiment of the present invention provides a bit that comprises drive surfaces which are formed of polygon involutes formed of one or more arcs, or is a single arc
15 construction. With regard to the arcs that define the drive surfaces, preferably each arc has a constant radius (i.e., is a segment of a circle).

Another embodiment of the present invention provides a punch that comprises surfaces which are formed of polygon involutes formed of one or more arcs, or is a single arc
construction. With regard to the arcs that define the surfaces, preferably each arc has a constant radius (i.e., is a segment of a circle).

20

Brief Description of the Drawings

The organization and manner of the structure and operation of the invention, together with further objects and advantages thereof, may best be understood by reference to the following description taken in connection with the accompanying drawings wherein like
5 reference numerals identify like elements in which:

Figure 1 illustrates a recess (or punch) which in accordance with an embodiment of the present invention;

Figure 2 is a cross-sectional view of a bit which corresponds to the recess shown in Figure 1;

10 Figure 3 shows the bit of Figure 2 inserted in the recess of Figure 1;

Figure 4 is similar to Figure 3, but shows the bit and recess after the bit has been rotated into full surface contact with driving walls of the recess

Figure 5 is an enlarged view which clearly shows the full surface contact;

15 Figure 6 is an enlarged view which shows a gap between the bit and the recess before the bit is rotated;

Figures 7 and 8 show portions of the recess shown in Figure 1, but also indicate some dimensions thereof;

Figures 9 and 10 show portions of the bit shown in Figure 2, but also indicate some dimensions thereof;

20 Figures 11-13 provide views relating to the recess shown in Figure 1;

Figures 14-21 provide views relating to alternative embodiments;

Figure 22 is a view which compares the embodiments; and

Figures 23-27 illustrate different versions of extending walls provided between lobes of the recess.

Description of Illustrated Embodiments

While this invention may be susceptible to embodiment in different forms, there are shown in the drawings and will be described herein in detail, specific embodiments with the understanding that the present disclosure is to be considered an exemplification of the principles
5 of the invention, and is not intended to limit the invention to that as illustrated.

A plurality of embodiments of the present invention is disclosed herein. Each embodiment provides a drive system with full surface drive contact. Specifically, each embodiment includes a fastener, wherein the fastener includes a recess which comprises drive surfaces which are formed of either polygon involutes or is provided as being a single arc
10 construction.

With regard to the term “involute,” an involute is the locus of a point, initially on a base circle, which moves so that its straight line distance, along a tangent to the circle, to the tangential point of contact, is equal to the distance along the arc of the circle from the initial point to the instant point of tangency. Alternatively, an involute is the locus of a point on a
15 straight line when the straight line rolls round the circumference of a circle without slipping. The involute is best visualized as the path traced out by the end of, for example, string or a piece of cotton, when the string or cotton is unrolled from its cylindrical reel.

To produce an involute profile, a line is traceable by unwinding, for example, a string from a cylinder. The cylinder can be referred to as the base circle. At any point during this
20 unwinding, the generation line (i.e., the string) is at a tangent with the cylinder and is normal to

the involute curve. If two involute profiles were in contact with each other, the generating line would be tangent to both cylinders, which is often called the pressure line.

Mathematically, an involute curve is taken from the following equation:

$$\theta = \beta - \tan^{-1} \sqrt{\frac{R^2 - R_b^2}{R_b}}$$

Wherein R = the radius to any point on the involute; θ = the angle from the start of the involute to radius R; and β = the angle through which the string has to be unwound.

With the generating line length equal to $\sqrt{R^2 - R_b^2}$ and also the length of the circumference of the base circle subtended by the angle β such that

$$\sqrt{R^2 - R_b^2} = R_b \beta \text{ or } \beta = \frac{\sqrt{R^2 - R_b^2}}{R_b}$$

And through substitution

$$\theta = \frac{\sqrt{R^2 - R_b^2}}{R_b} - \tan^{-1} \frac{\sqrt{R^2 - R_b^2}}{R_b}$$

10 This allows the plotting of the involute curve in polar coordinates (R, θ).

It is common to write the angle as a function of the pressure angle (φ) in the form

$$\theta = \tan \varphi - \varphi = Inv \varphi$$

Where *Inv* φ is the Involute function, whose value is tabulated in many books for different gears. This can then be used in many calculations such as the determination of tooth thickness (T_1) at different radii, using the equations below.

$$\cos \varphi_2 = \frac{r_1 \cos \varphi_1}{r_2}$$

$$T_2 = 2r_2 \left[\frac{T_1}{2r_1} + \text{Inv}\varphi_1 - \text{Inv}\varphi_2 \right]$$

It should be pointed out that a fastener, bit, punch, etc. comprising the present invention may have drive surfaces which are not perfect polygon involutes under a microscope, given real life manufacturing processes and materials.

Figure 1 illustrates a recess 10, such as a recess in a fastener 11 or other structure (Figure 5 1 may also illustrate the end surface profile of a punch 10), where the recess 10 is in accordance with a preferred embodiment of the present invention. Specifically, the recess 10 is configured to provide a plurality of lobes 12, each having drive surfaces 14 which are formed of polygon involutes. In the preferred embodiment, each drive surface is formed of a polygon involute comprised of two arcs, wherein each arc has a different radius, but each arc has a constant radius 10 (i.e., each arc is a segment of a circle). Between each lobe 12 is a flute 16 which provides a wall 18 which extends between adjoining lobes 12. These walls 18, and the different shapes they may take, will be described in more detail later hereinbelow.

Figure 2 provides a cross-sectional view of a corresponding external drive such as a bit 20, where the bit 20 is provided in association with the recess 10 shown in Figure 1, and where 15 the bit 20 is in accordance with a preferred embodiment of the present invention. Specifically, the profile of the external surface of the bit 20 corresponds to the profile of the recess 10 shown in Figure 1, such that the bit 20 is insertable in the recess 10, and is rotatable in either a

clockwise or counter clockwise direction in order to drive the fastener in which the recess 10 is formed.

The bit 20 corresponds to the recess 10. As such, the bit 20 comprises a plurality of lobes 21, each lobe 21 comprising drive surfaces or drive walls 24 which are formed of polygon involutes. More specifically, preferably the drive surfaces 24 are formed of polygon involutes 5 comprised of two arcs, and each arc has a constant radius (i.e., is a segment of a circle). Preferably, each of the walls 23 between the flutes 21 is at least one of flat, concave circular, convex vertex and concave vertex, as will be described more fully hereinbelow.

When the bit 20 is initially inserted in the recess 10, the bit 20 and recess 10 may appear 10 as shown in Figure 3, wherein there are gaps 21 between drive walls 24 of the bit 20 and the drive walls 14 of the recess 10. Assuming the bit 20 is then rotated clockwise, the bit 20 and recess 10 may appear as shown in Figure 4, wherein leading walls 26 of the bit 20 engage corresponding drive walls 14 of the recess 10, while trailing walls 28 of the bit 20 are spaced away from corresponding drive walls 14 of the recess 10 to provide gaps 22.

15 The full surface contact between the leading walls 26 of the bit 20 and the corresponding drive walls 14 of the recess 10 can best be seen in Figure 5, which provides an enlarged view of the interface between one of the leading walls 26 of the bit 20 and one of the drive walls 14 of the recess 10. The full surface contact extends from point 30 to point 32. On the other hand, the gap 21 between the leading walls 26 of the bit 20 and the corresponding drive walls 14 of the 20 recess 10 before the bit 20 is rotated can best be seen in Figure 6, which provides an enlarged view of one of the leading walls 26 of the bit 20 and the corresponding drive wall 14 of the

recess 10. As shown in Figure 4, but for the surface contact between points 30 and 32, the gap 22 between the bit 20 and the recess 10 is constant, and preferably remains constant while the bit 20 rotates.

While other configurations are disclosed herein, the two arc polygon involute
5 configuration shown in Figures 1 and 2 is preferred. With this configuration, the blend radius (i.e., the section between each of the arcs) does not get washed away. Additionally, a minimal gap 22 is provided between the bit and recess. While each arc preferably has a different radius, each arc preferably has a constant radius (i.e., each arc is a segment of a circle). The A and B dimensions shown in Figure 1 are diameters. Having these diameters aids in the measurement of
10 this feature, provides more lobular width in the A dimension, reduces the chance of chipping of the heading tool, and increases the bit area at the lobes.

Figure 7 shows a portion of the recess shown in Figure 1, and indicates some of the dimensions. Figure 8 shows just one of the driving walls of the recess, and indicates some other dimensions, including the radius (R1 and R2) of each of the two arcs. As shown, while R1 does
15 not equal R2, each one of R1 and R2 is constant. With regard to the actual values of each of the dimensions, one specific embodiment may provide that, for example (all values being in inches), R1=0.0198752778, R2=0.0397505556, A=0.155, B=0.1206, Fa=0.0086, Fb=0.0360759556, Ea=0.0086, Eb=0.0360759556, P=0.0689, S=0.0689, Ra=0.007 and Rb=0.005. With regard to Gr and G, Gr may be 17.9021442092 degrees and G (REF) may be 18.9716157232 degrees.
20 This is just one embodiment of the present invention, and plenty other sizes, shapes, etc. are entirely possible while still staying within the scope of the present invention.

Figures 9 and 10 are similar to Figures 7 and 8, but relate to the bit 20 shown in Figure 2. As shown, the bit has a shape which corresponds to the recess. Figures 11-13 provide a plurality of views relating to the two arc configuration and are self-explanatory.

Figures 14-16 provide a plurality of views relating to an alternative embodiment and are also self-explanatory. Specifically, Figure 14-16 show a configuration where each of the drive walls of the recess is provided as being formed of a polygon involute comprising one arc, said arc having a constant radius (i.e., it is a segment of a circle).

Figures 17-19 provide a plurality of views relating to yet another embodiment and are self-explanatory. Specifically, Figure 17-19 show a configuration where each of the drive walls of the recess is provided as being formed of a polygon involute comprising three arcs, wherein each arc has a different radius, but each arc has a constant radius (i.e., each arc is a segment of a circle).

Figures 20-21 provide a plurality of views relating to a still further embodiment and are self-explanatory. Specifically, Figure 20-21 show a configuration where each of the drive walls of the recess are provided as being of a single arc construction, wherein the radius of the arc is constant (i.e., the arc is a segment of a circle).

Figure 22 is a view which compares the different embodiments. Reference numeral 200 identifies circle involute-high precision, reference numeral 202 identifies a polygon involute-1 arc, reference numeral 204 identifies a polygon involute-2 arcs, reference numeral 206 identifies a polygon involute-3 arcs, and reference numeral 208 identifies a one arc construction (perpendicular arc).

Figures 1 and 2 illustrate a configuration wherein walls 18 between the lobes 12 are provided as being flat. This is shown very well in Figure 23, which shows the recess 10 on the left, the bit 20 on the right. This is a preferred configuration with regard to walls 18 because it provides that the walls 18, collectively define a hexagon shape, thus a hex tool can be inserted in the recess and used to drive the fastener (in addition to the corresponding bit shown on the right in Figure 23).

Each of Figures 24-27 shows an alternative embodiment, and in each case the recess is shown on the left, and the corresponding bit (similarly shaped) is shown on the right. In the embodiment shown in Figure 24, each of the walls 18 between the flutes is semi-circular (i.e., convex circular) and identifies the circle with reference numeral 40.

In the embodiment shown in Figure 25, each of the walls 18 between the lobes 14 is concave circular. In the embodiment shown in Figure 26, each of the walls 18 between the lobes 14 is a convex vertex. In the embodiment shown in Figure 27, each of the walls 18 between the lobes 14 is a concave vertex.

Although the depths of none of the recesses disclosed herein has been specifically shown or described, the depth of any of the recesses can take any appropriate form, depending on the application, and the desired properties of the drive system. For example, the depth can be flat (for example, the depth at the bottom of the recess can be flat), conical, have a spherical bottom, etc. For example, the depth may be such that each of the driving walls is semi-cylindrical with regard to going down into the recess.

With regard to the bit provided to engage any of the recesses disclosed herein, preferably the bit is provided as being slightly helical (i.e., pre-twisted). This way the use of an area contact pattern recess geometry is combined with a corresponding slightly helical bit geometry.

Consequently, at near zero reaction torque, the end of the bit first contacts the recess and, as the
5 torque increases, the bit-recess surface contact pattern area expands and extends from the end of the bit to the top of the recess.

While embodiments of the present invention have been described as being implemented in the form of a recess in the head of a fastener, embodiments may take the form of the external drives (such as bits) having external profiles which are consistent with the recesses which have
10 been described. In fact, the drawings provided herein would even apply to such embodiments as well. Additionally, while the drawings show a six lobe system, the present invention can be implemented with regard to systems involving either more or fewer lobes, such as three, four or five lobe systems.

While specific embodiments of the invention have been shown and described, it is
15 envisioned that those skilled in the art may devise various modifications without departing from the spirit and scope of the present invention.

What is claimed is:

1. A fastener comprising a recess; a drive surface in the recess, said drive surface formed of at least one of polygon involutes and a single arc construction.
2. A fastener as recited in claim 1, wherein the recess is configured to provide a plurality of lobes, each lobe comprising drive surfaces which are formed of polygon involutes.
3. A fastener as recited in claim 1, wherein the recess is configured to provide a plurality of lobes, each lobe comprising drive surfaces which are formed of polygon involutes comprised of two arcs.
4. A fastener as recited in claim 3, wherein each arc has a different radius, and each arc has a constant radius where in each is a segment of a circle.
5. A fastener as recited in claim 3, further comprising a wall between each lobe, said wall being flat.
6. A fastener as recited in claim 3, further comprising a wall between each lobe, said wall being concave circular.
7. A fastener as recited in claim 3, further comprising a wall between each lobe, said wall being a convex vertex.
8. A fastener as recited in claim 3, further comprising a wall between each lobe, said wall being a concave vertex.
9. A bit comprising a drive surface, said surface formed of at least one of polygon involutes and a single arc construction.

10. A bit as recited in claim 9, wherein the bit comprises a plurality of flutes, each flute comprising surfaces which are formed of polygon involutes.

11. A bit as recited in claim 9, wherein the bit comprises a plurality of flutes, each flute comprising surfaces which are formed of polygon involutes comprised of two arcs.

5 12. A bit as recited in claim 11, wherein each arc has a different radius, and each arc has a constant radius, wherein each is a segment of a circle.

13. A bit as recited in claim 11, further comprising a wall between each flute, said wall being flat.

10 14. A bit as recited in claim 11, further comprising a wall between each flute, said wall being concave circular.

15 15. A bit as recited in claim 11, further comprising a wall between each flute, said wall being at least one of convex vertex and concave vertex.

16. A punch comprising a surface, said surface formed of at least one of polygon involutes and a single arc construction.

15 17. A punch as recited in claim 16, wherein the punch comprises a plurality of flutes, each flute comprising surfaces which are formed of polygon involutes.

18. A punch as recited in claim 16, wherein the punch comprises a plurality of flutes, each flute comprising surfaces which are formed of polygon involutes comprised of two arcs.

20 19. A punch as recited in claim 16, wherein each arc has a different radius, and each arc has a constant radius, wherein each is a segment of a circle.

20. A punch as recited in claim 16, further comprising a wall between each flute, said wall being flat, concave circular, convex vertex or concave vertex.

FIG. 1

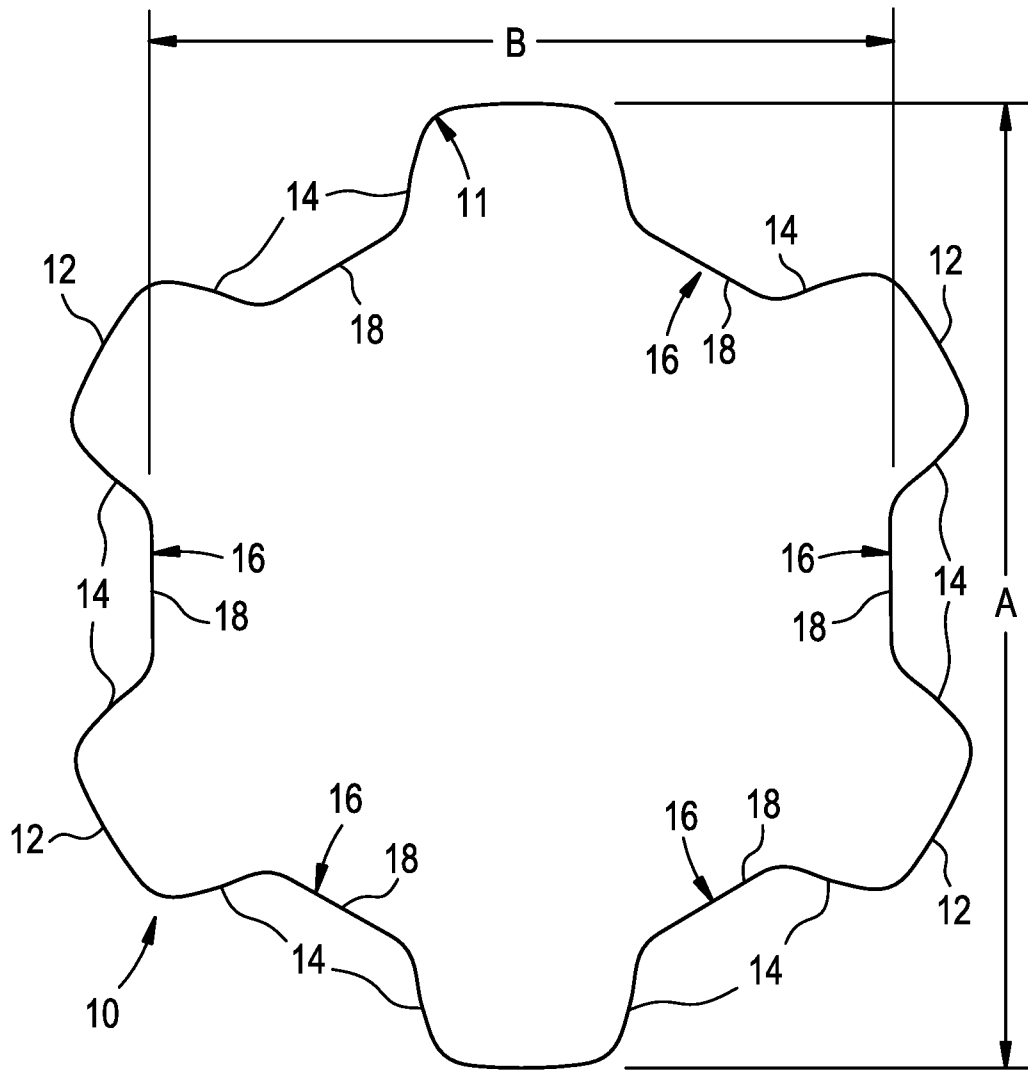

FIG. 2

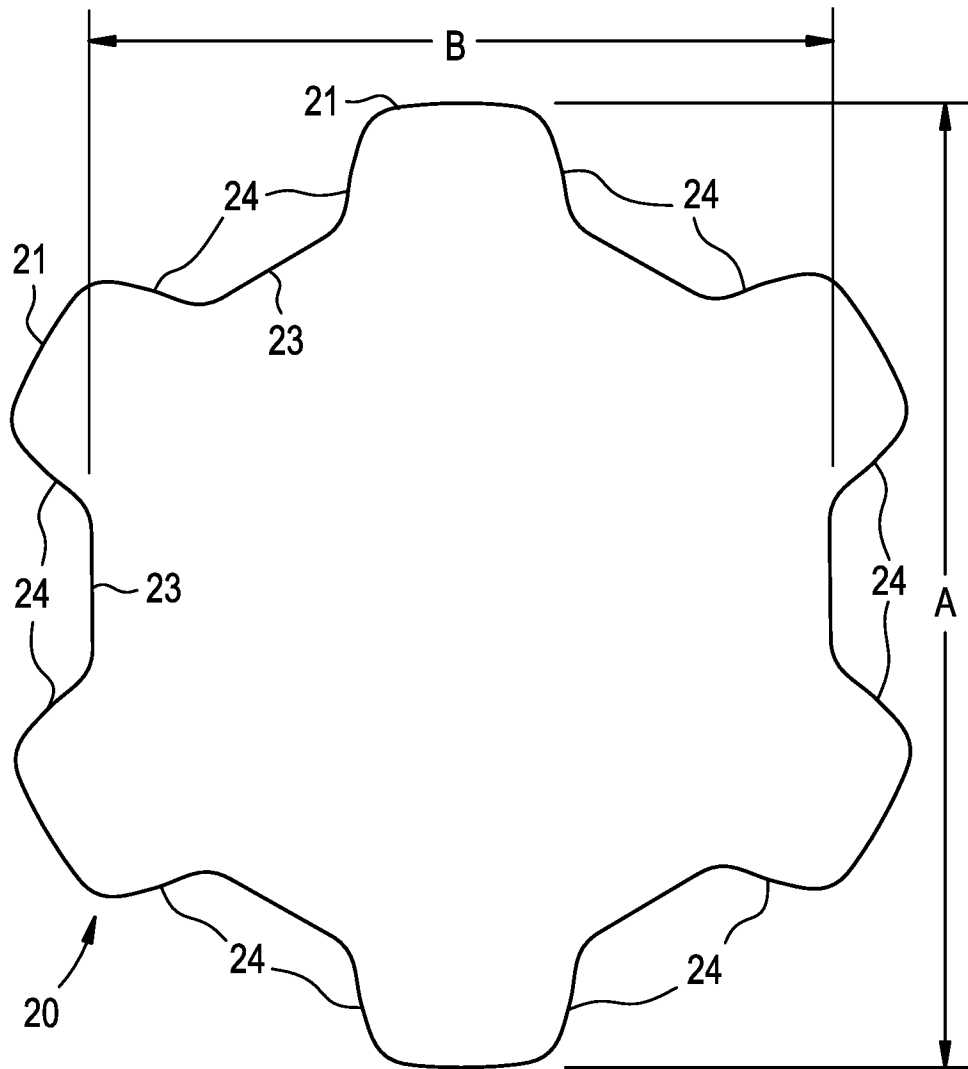

FIG. 3

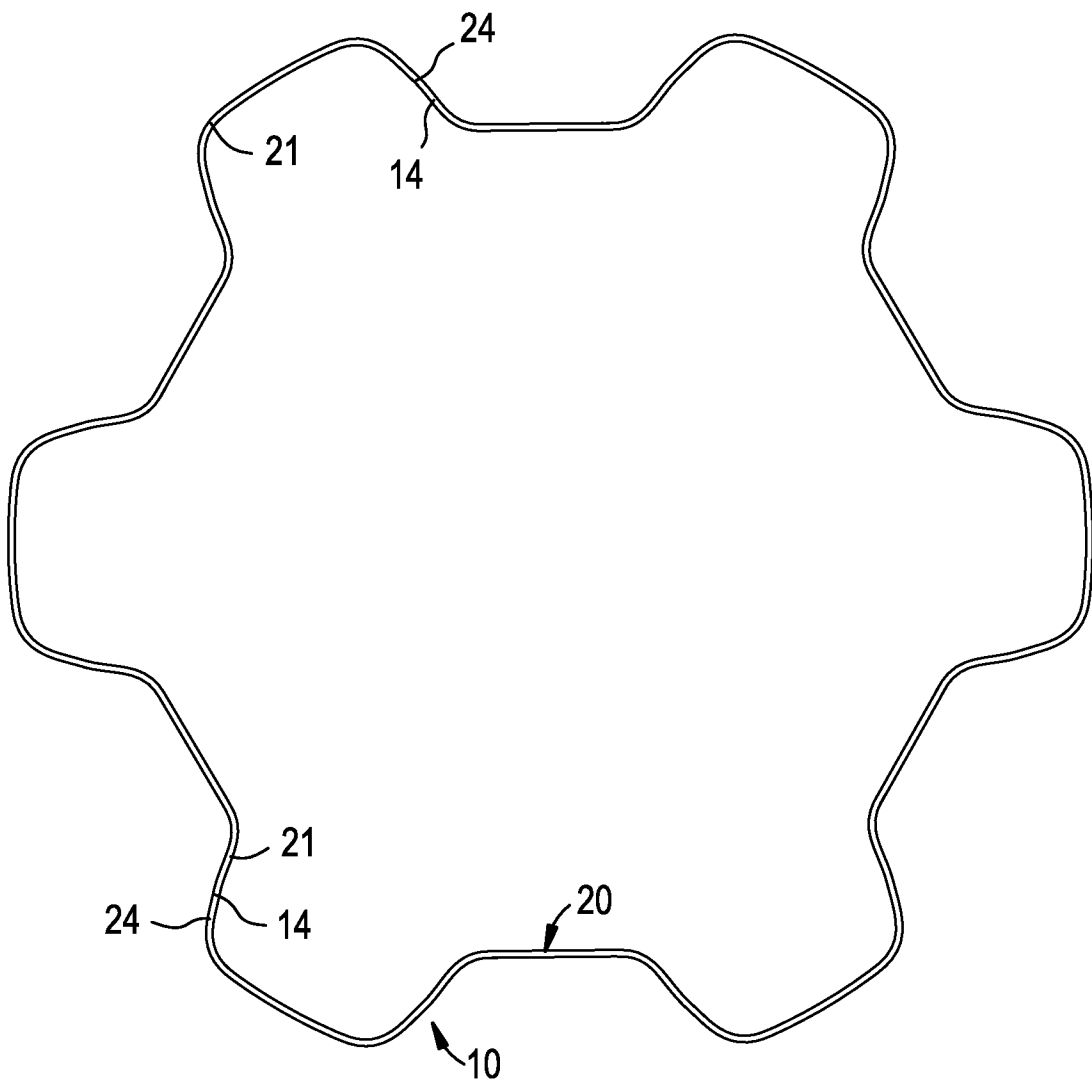

FIG. 4

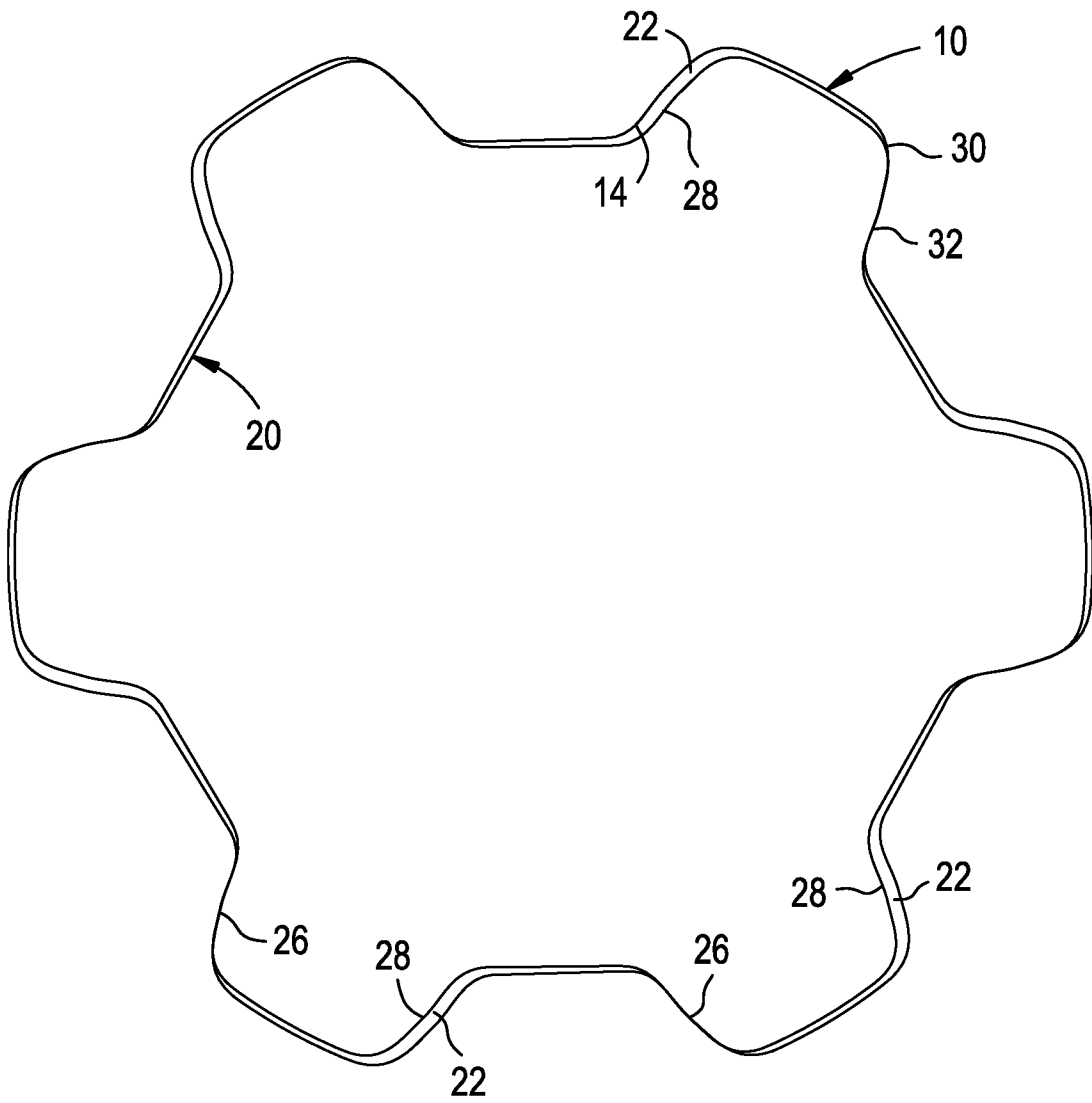

FIG. 5

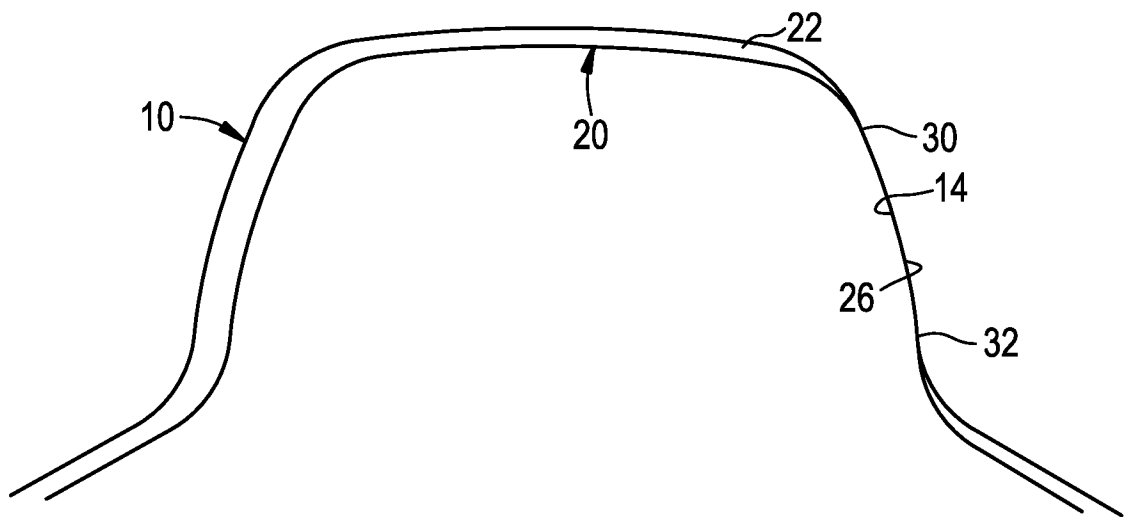

FIG. 6

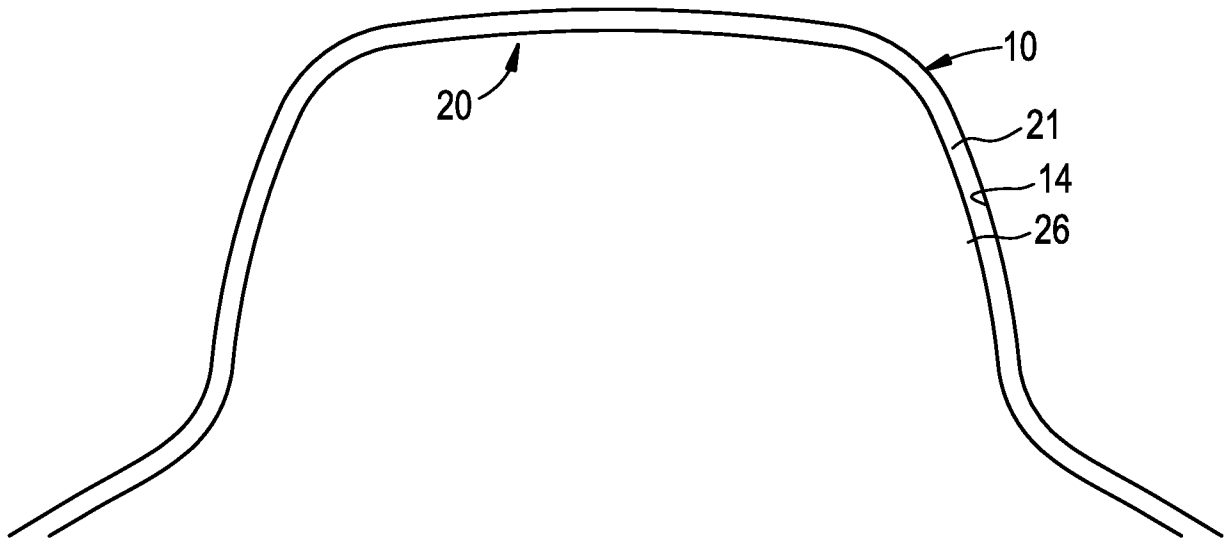

FIG. 7

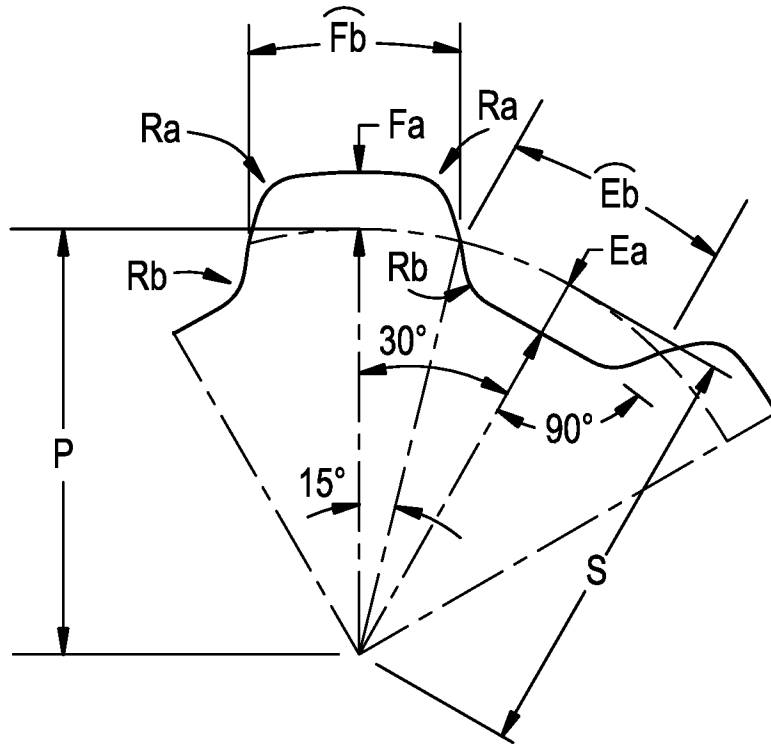

FIG. 8

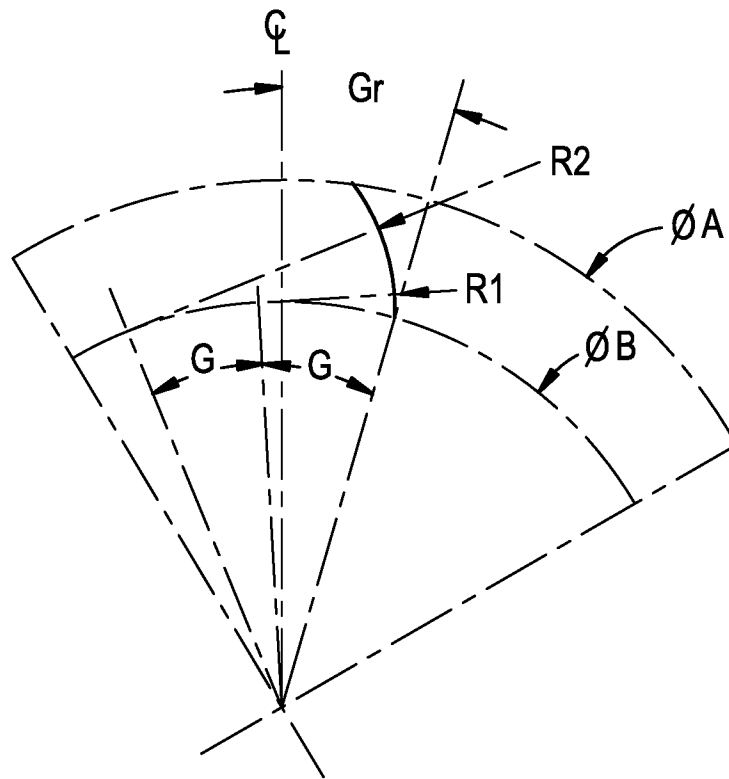

FIG. 9

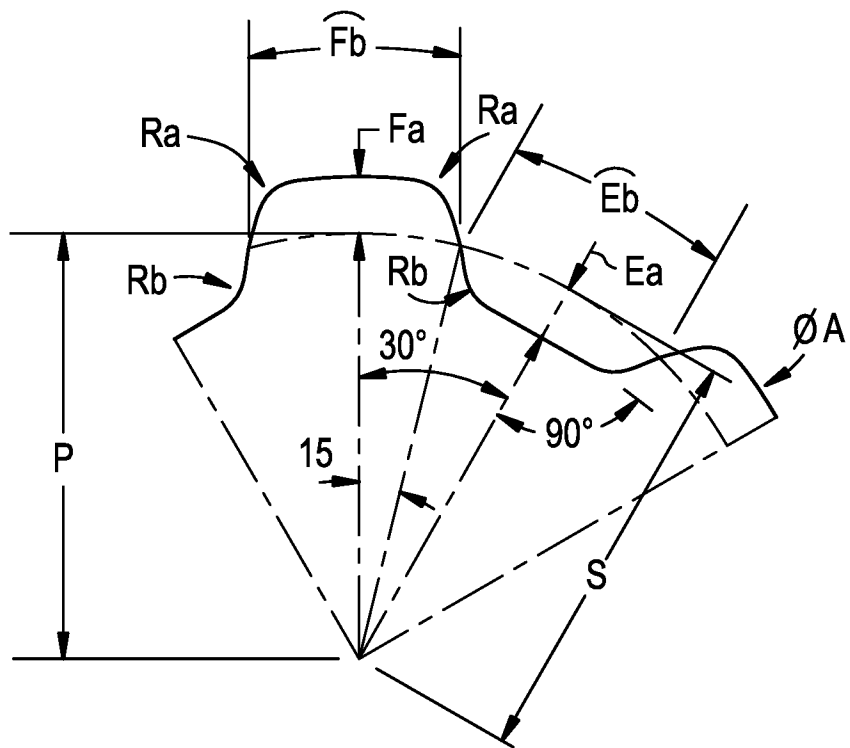

FIG. 10

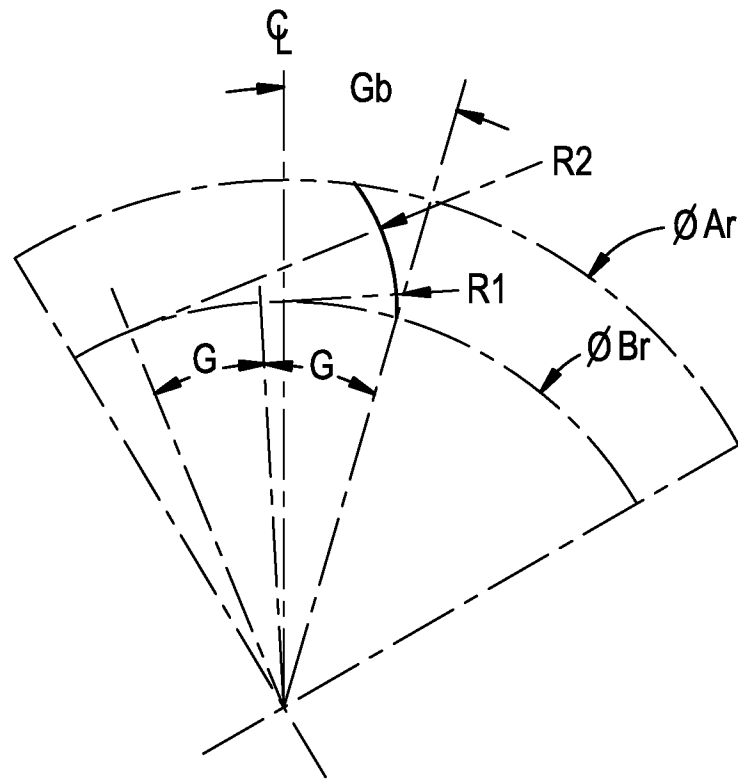

FIG. 11

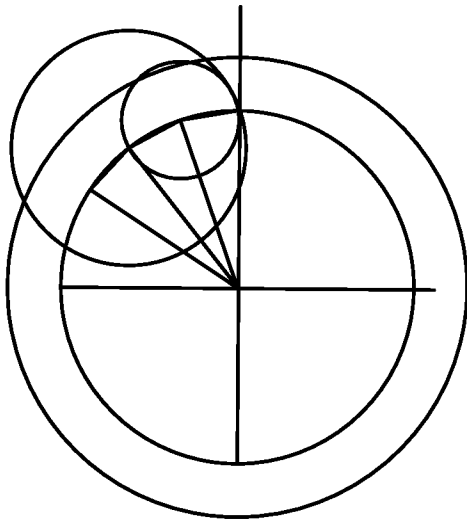

FIG. 12

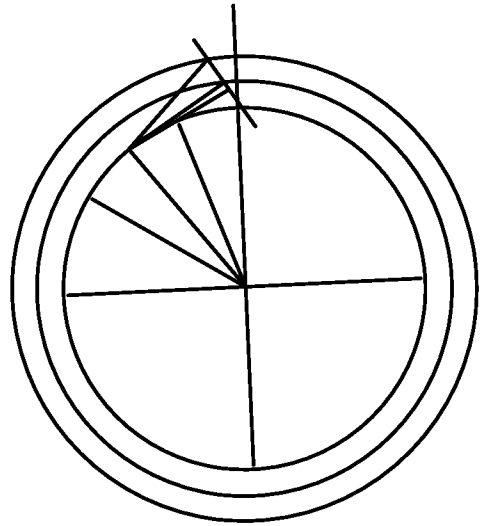

FIG. 13

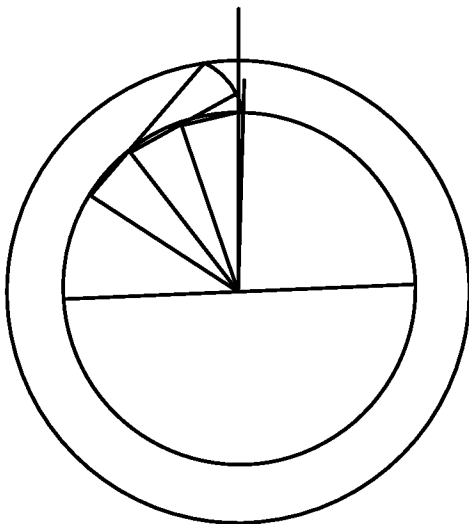

FIG. 14

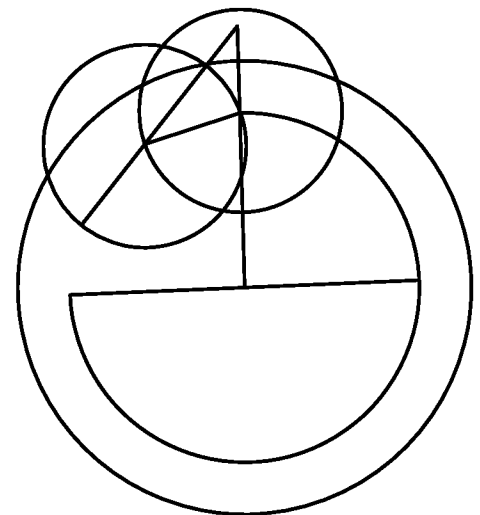

FIG. 15

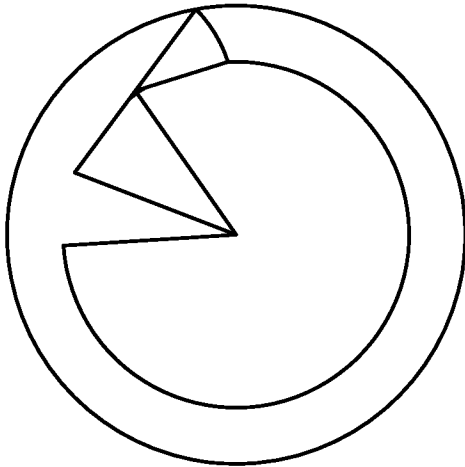

FIG. 16

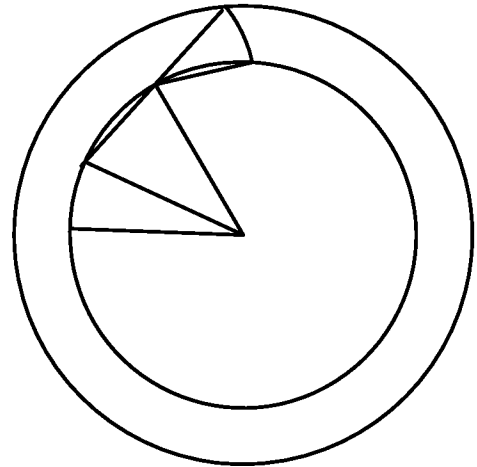

FIG. 17

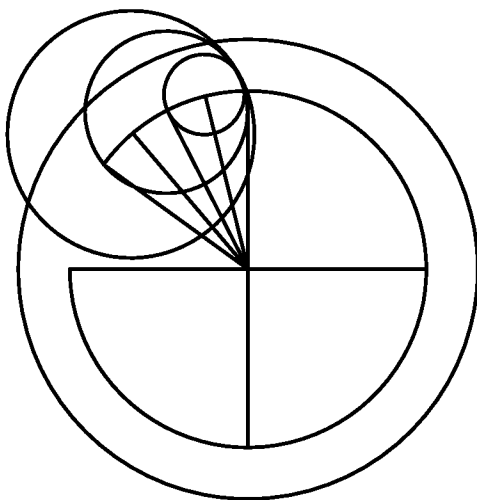

FIG. 18

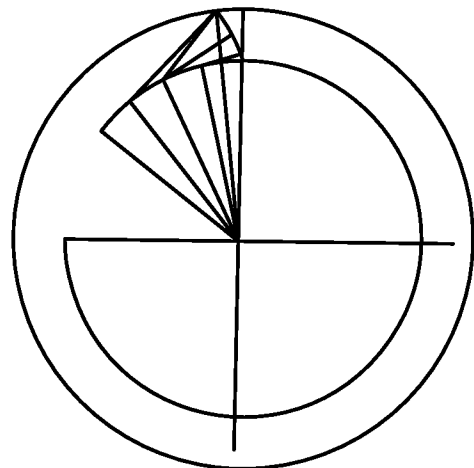

FIG. 19

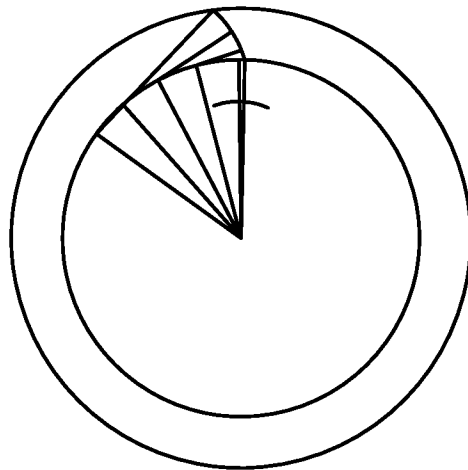

FIG. 20

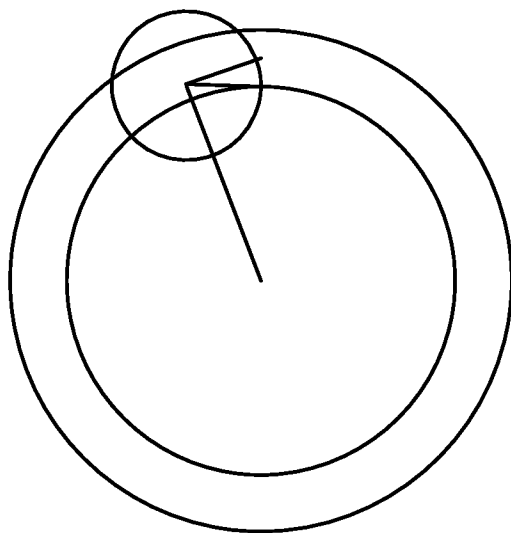

FIG. 21

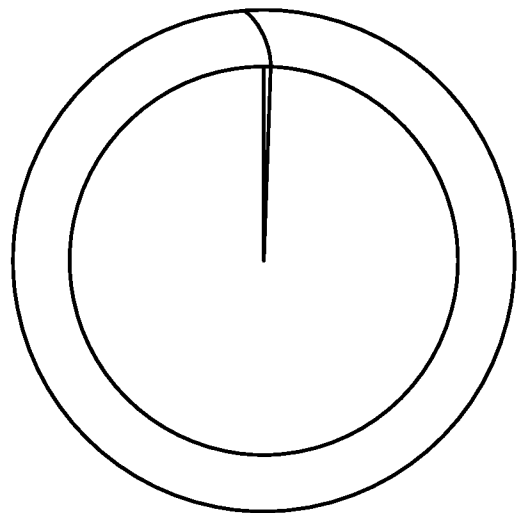

FIG. 22

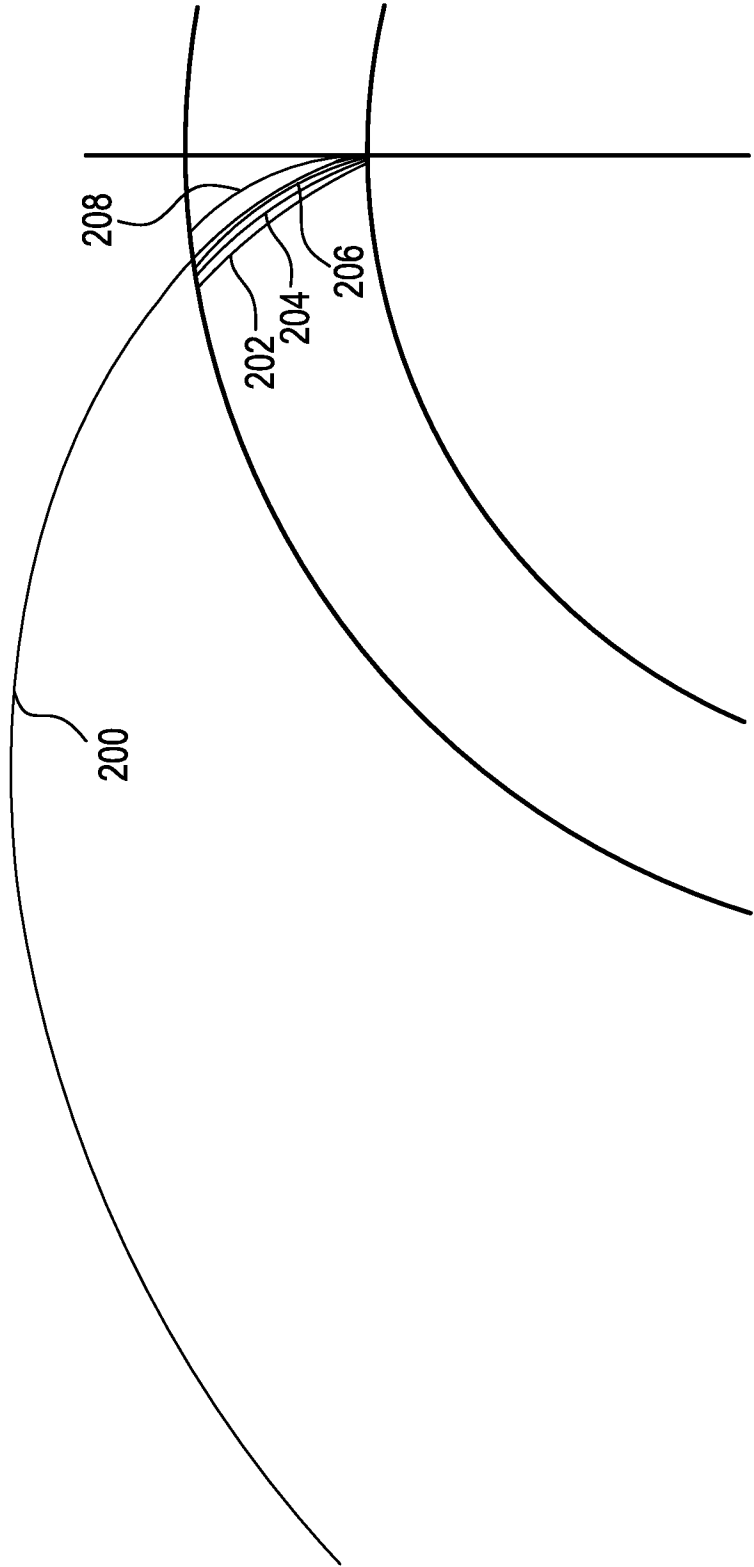

FIG. 23

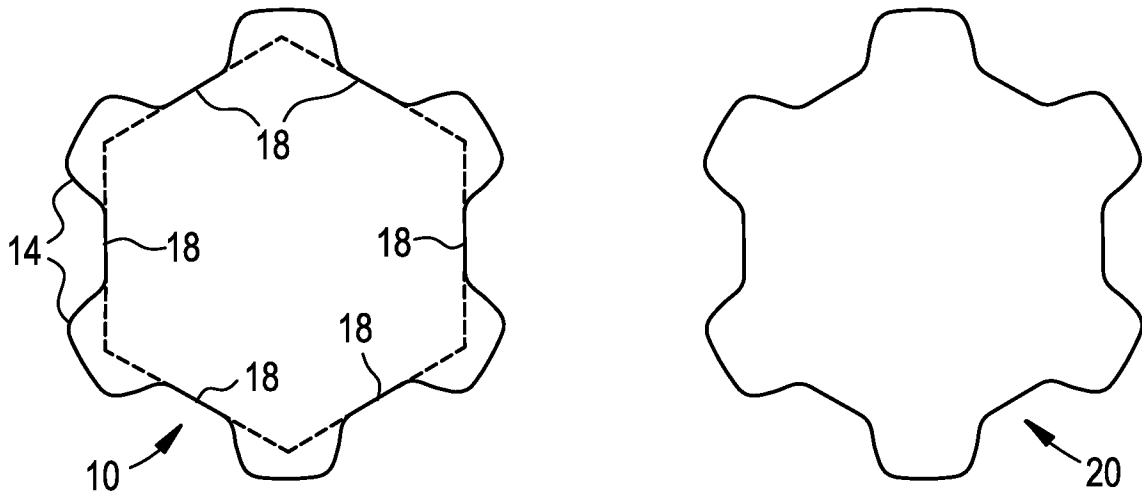

FIG. 24

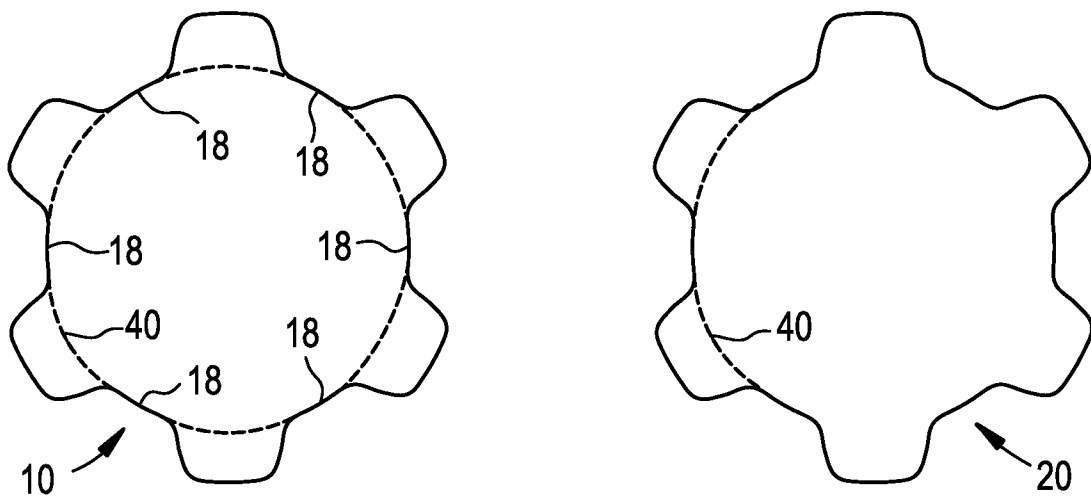

FIG. 25

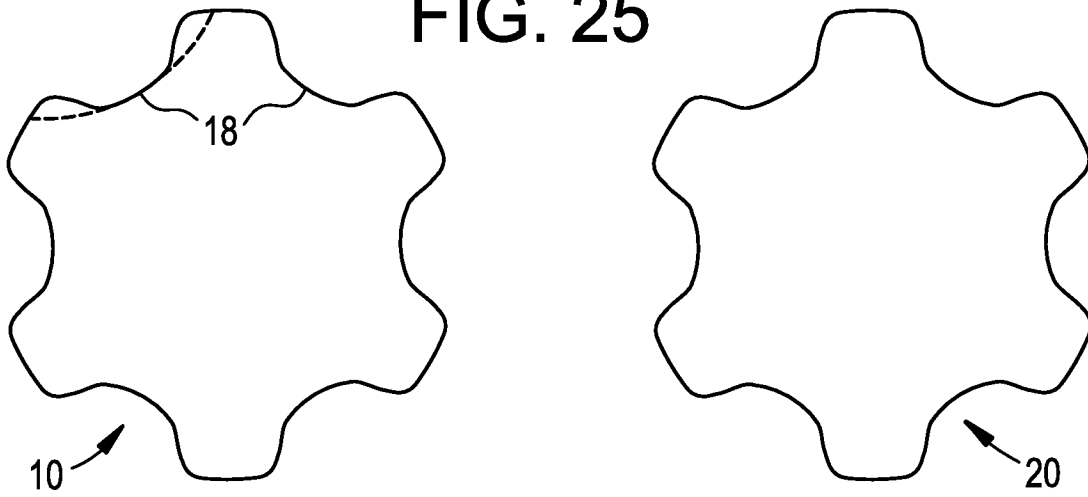

FIG. 26

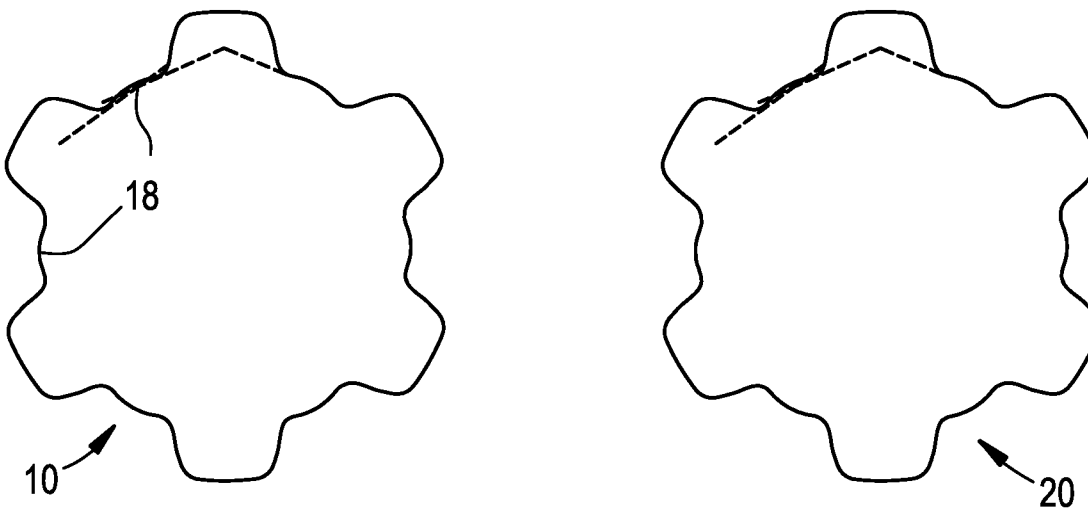
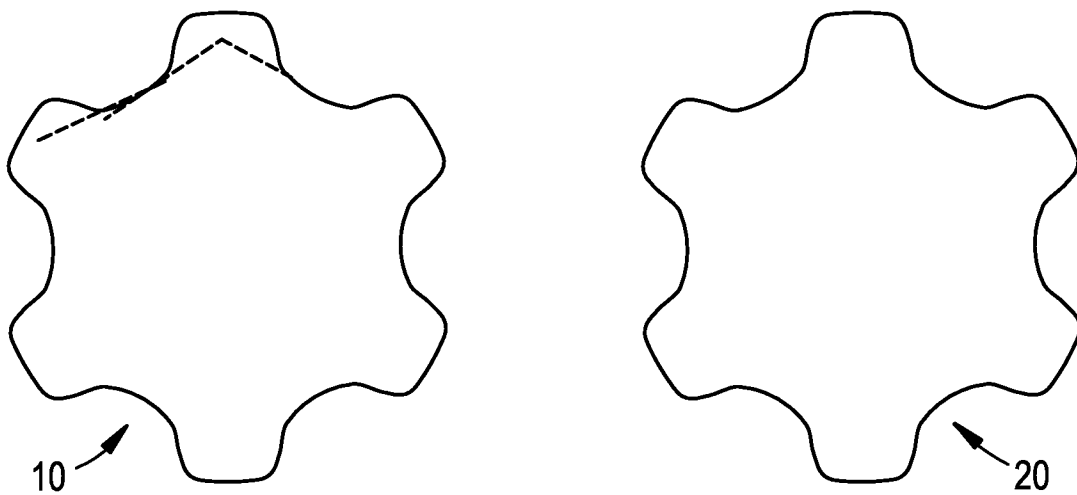

FIG. 27



INTERNATIONAL SEARCH REPORT

International application No.

PCT/US2016/022927

A. CLASSIFICATION OF SUBJECT MATTER		
IPC(8) - B25B 15/00; F16B 23/00; F16B 35/04; F16B 35/06 (2016.01)		
CPC - B25B 15/001; F16B 23/0007; B25B 15/004; B25B 15/005; F16B 23/00; F16B 23/0046 (2016.05)		
According to International Patent Classification (IPC) or to both national classification and IPC		
B. FIELDS SEARCHED		
Minimum documentation searched (classification system followed by classification symbols)		
IPC(8) - B25B 15/00; F16B 23/00; F16B 35/04; F16B 35/06 (2016.01)		
CPC - B25B 15/00; B25B 15/001; B25B 15/004; B25B 15/005; B25B 15/008; F16B 23/00; F16B 23/0007; F16B 23/0023; F16B 23/003; F16B 23/0038; F16B 23/0046 (2016.05)		
Documentation searched other than minimum documentation to the extent that such documents are included in the fields searched		
USPC - 81/52; 81/436; 81/437; 411/402; 411/403; 411/404; 411/410; 470/63; 470/205 (keyword delimited)		
Electronic data base consulted during the international search (name of data base and, where practicable, search terms used)		
PatBase, Google Patents, Google, Google Scholar, YouTube		
Search terms used: acument, polyqon, involutes, fastener, drive, surface, single, arc		
C. DOCUMENTS CONSIDERED TO BE RELEVANT		
Category*	Citation of document, with indication, where appropriate, of the relevant passages	Relevant to claim No.
X	US 5,957,645 A (STACY) 28 September 1999 (28.09.1999) entire document	1-3, 9-11, 14, 16-18, 20
---		---
Y		4-8, 12, 13, 15, 19
Y	US 2010/0129176 A1 (KARUPAYA) 27 May 2010 (27.05.2010) entire document	4, 12, 19
Y	US 5,577,871 A (BRUGOLA) 26 November 1996 (26.11.1996) entire document	5, 7, 13
Y	US 2004/0149088 A1 (YAMAMOTO) 05 August 2004 (05.08.2004) entire document	6, 15
Y	US 2013/0068075 A1 (STIEBITZ et al) 21 March 2013 (21.03.2013) entire document	8
A	US 2002/0039523 A1 (HARTMANN et al) 04 April 2002 (04.04.2002) entire document	1-20
A	US 2007/0037123 A1 (MANSUETO et al) 15 February 2007 (15.02.2007) entire document	1-20
A	US 2011/0203423 A1 (DILLING) 25 August 2011 (25.08.2011) entire document	1-20
<input type="checkbox"/> Further documents are listed in the continuation of Box C. <input type="checkbox"/> See patent family annex.		
* Special categories of cited documents:		
"A"	document defining the general state of the art which is not considered to be of particular relevance	"T" later document published after the international filing date or priority date and not in conflict with the application but cited to understand the principle or theory underlying the invention
"E"	earlier application or patent but published on or after the international filing date	"X" document of particular relevance; the claimed invention cannot be considered novel or cannot be considered to involve an inventive step when the document is taken alone
"L"	document which may throw doubts on priority claim(s) or which is cited to establish the publication date of another citation or other special reason (as specified)	"Y" document of particular relevance; the claimed invention cannot be considered to involve an inventive step when the document is combined with one or more other such documents, such combination being obvious to a person skilled in the art
"O"	document referring to an oral disclosure, use, exhibition or other means	"&" document member of the same patent family
"P"	document published prior to the international filing date but later than the priority date claimed	
Date of the actual completion of the international search	Date of mailing of the international search report	
08 May 2016	26 MAY 2016	
Name and mailing address of the ISA/ Mail Stop PCT, Attn: ISA/US, Commissioner for Patents P.O. Box 1450, Alexandria, VA 22313-1450 Facsimile No. 571-273-8300	Authorized officer Blaine R. Copenheaver PCT Helpdesk: 571-272-4300 PCT OSP: 571-272-7774	