

Dec. 4, 1923.

1,476,263

J. J. MARTIN

ROAD WORKING APPARATUS

Filed Jan. 4, 1922

2 Sheets-Sheet 1

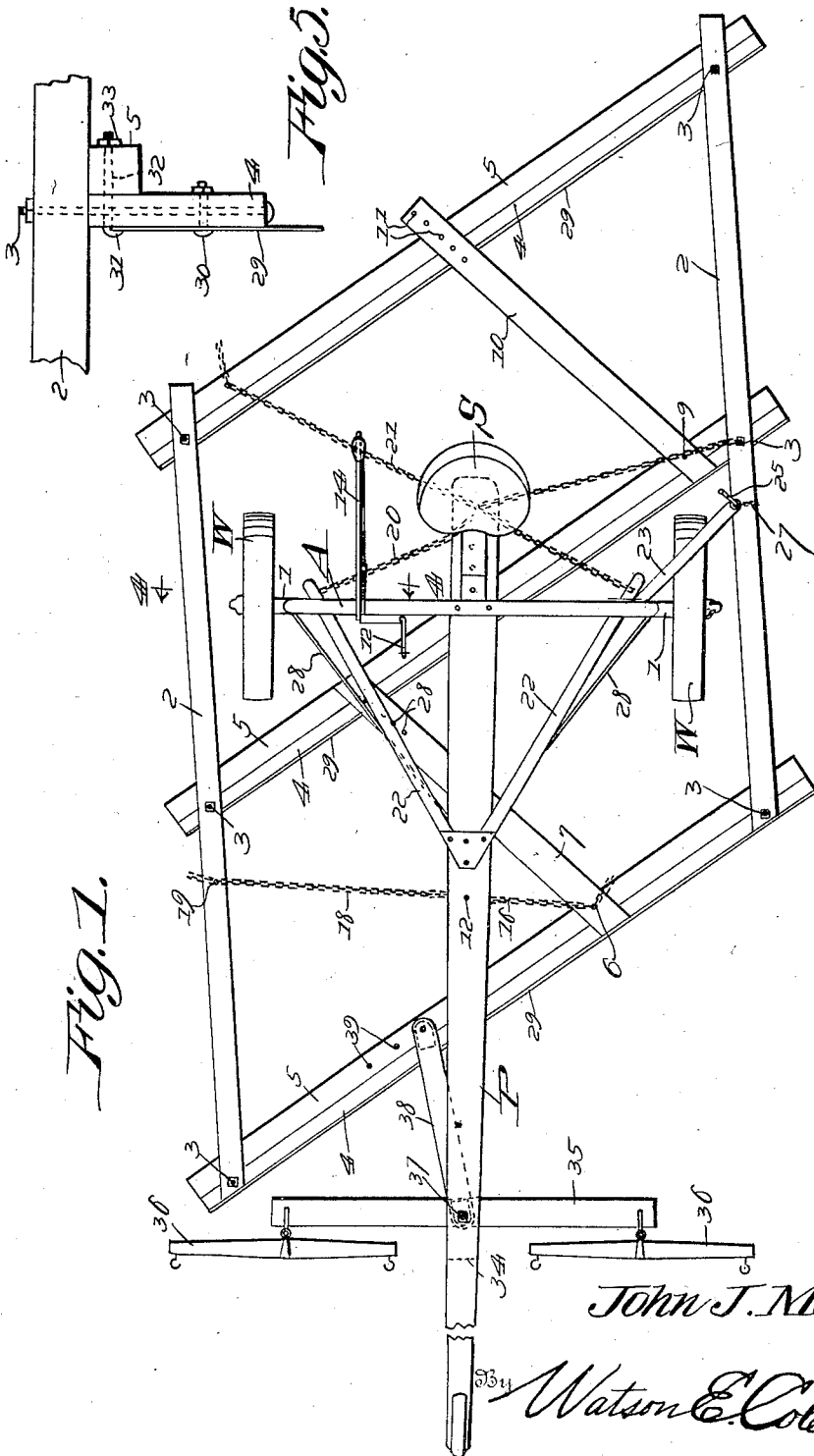

Fig. 1.

Fig. 5.

Inventor

John J. Martin,

Watson E. Coleman
Attorney

Dec. 4, 1923.

1,476,263

J. J. MARTIN

ROAD WORKING APPARATUS

Filed Jan. 4, 1922

2 Sheets-Sheet 2

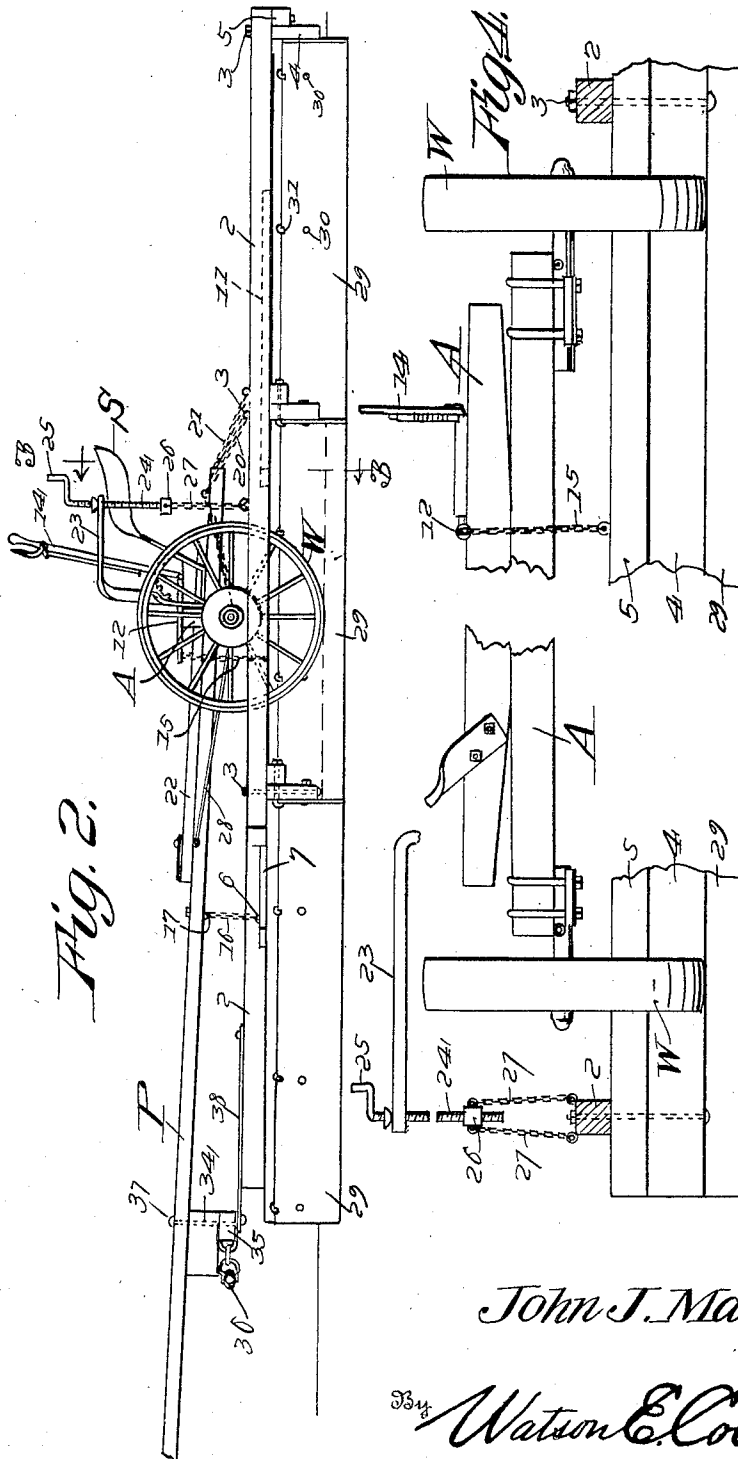

Fig. 2.

Fig. 3.

Inventor
John J. Martin,

Watson E. Coleman
Attorney

UNITED STATES PATENT OFFICE.

JOHN J. MARTIN, OF HILL CITY, MINNESOTA.

ROAD-WORKING APPARATUS.

Application filed January 4, 1922. Serial No. 526,922.

To all whom it may concern:

Be it known that I, JOHN J. MARTIN, a citizen of the United States, residing at Hill City, in the county of Aitkin and State of Minnesota, have invented certain new and useful Improvements in Road-Working Apparatus, of which the following is a specification, reference being had to the accompanying drawings.

10 This invention relates to certain improvements in road working apparatus, and it is an object of the invention to provide a device of this general character embodying novel and improved means whereby the same may be employed to advantage in the treating of a roadway and which is of such a character to also operate as a planer or grader.

20 Another object of the invention is to provide a novel and improved device of this general character comprising a portable supporting structure and a plurality of ground working members carried thereby, said ground working members being capable of adjustment independently of the supporting structure.

30 An additional object of the invention is to provide a device of this general character comprising a portable structure provided with ground working elements, together with means whereby the major portion of the draft is imposed upon the ground working elements whereby the efficiency of said elements is materially increased.

35 It is also an object of the invention to provide a novel and improved device of this general character employing a ground working element having a thin blade for direct engagement with the surface to be worked and which blade is of such a character to be reversed edge for edge and end for end whereby the life of said blade may be materially prolonged.

45 Furthermore, it is an object of the invention to provide a novel and improved device of this general character embodying a portable structure and a drag or planer structure flexibly connected with the portable

structure so that the planer or grader structure may have movement independently of the portable structure.

The invention consists in the details of construction and in the combination and arrangement of the several parts of my improved road working apparatus whereby certain important advantages are attained and the device rendered simpler, less expensive and otherwise more convenient and advantageous for use, as will be hereinafter more fully set forth.

The novel features of my invention will hereinafter be definitely claimed.

In order that my invention may be the better understood, I will now proceed to describe the same with reference to the accompanying drawings, wherein:

Figure 1 is a view in top plan illustrating a ground working apparatus constructed in accordance with an embodiment of my invention;

Figure 2 is a view in side elevation of the apparatus as herein disclosed;

Figure 3 is a fragmentary view partly in elevation and partly in section illustrating the means for imparting movement to one side of the ground working structure in a vertical direction;

Figure 4 is a fragmentary view partly in elevation and partly in section illustrating in detail a means for moving the ground working structure substantially bodily in a vertical direction; and

Figure 5 is a fragmentary view in end elevation of one of the ground working elements and illustrating in detail a means for securing a working blade in applied position.

As disclosed in the accompanying drawings, A denotes an arched axle having mounted on the spindles 1 thereof the wheels W, said axle A and wheels W providing a portable structure. Suitably secured to the central portion of the arched axle A and extending forwardly therefrom is a pole P. The rear portion of the pole P has mounted thereon a seat structure S. This seat struc-

ture S is adjustable toward or from the axle A in order to effect a balance of the weight of the pole P.

The ground working structure comprises the elongated side members or beams 2 arranged substantially in parallelism and positioned outwardly of the wheels W, said members or beams 2 also extending forwardly and rearwardly of said wheels. The members or beams 2 overlie and are pivotally engaged, as at 3, with the transversely disposed members 4, each having a relatively broad flat forward face. The upper marginal portion of each of the members 4 has associated therewith a beam 5, said beam 5 being of a length coextensive to the length of the member 4.

As herein disclosed, the members 4 are three in number, one of said members being positioned forwardly of the axle A and the wheels W carried thereby, a second member 4 being positioned rearwardly of said portable structure, and the third member underlying the central portion of the axle A and terminating forwardly and rearwardly thereof. The members 4 are substantially in parallelism and disposed on a predetermined incline to the longitudinal axis of the apparatus and particularly as defined by the pole P.

Pivotally engaged, as at 6, with the forward beam 5 to one side of its longitudinal center is a rearwardly directed brace beam 7 and which is provided at its inner or opposite portion with the longitudinally spaced openings 8 whereby the same may be adjustably connected with the intermediate beam 5. The intermediate beam 5 adjacent an end thereof also has pivotally engaged therewith, as at 9, a rearwardly directed brace member 10. This member 10 also has a series of longitudinally spaced openings 11 whereby it may be adjustably connected with the rear beam 5. By providing the members 7 and 10 with means whereby the same may be adjustably connected to certain of the beams 5, it will at once be understood that the angle of the beams 5 and the associated members 4 may be readily varied in accordance with the requirements of practice.

The axle A to one side of its center is provided with a rock arm 12 with which is operatively engaged an upstanding operating lever 14. Connecting the rock arm 12 and the central or intermediate beam 5 to one side of its longitudinal center is a flexible member or chain 15.

Interposed between the pole P and the forward beam 5 is a flexible member or chain 16, said member or chain being herein disclosed as connected at 6 with the beam 5 and at 17 with the pole P. Also connected with the pole P at 17 is a second flexible member or chain 18, said flexible member or

chain 18 being secured, as at 19, to the side beam 2 remote from the connection 6. The members or chains 16 and 18 provide a flexible support for the forward portion of the ground working structure.

20 denotes a flexible member or chain secured to one end portion of the axle A and extending over and secured to the side beam 2 remote therefrom and preferably at the intermediate connection 3. Extending from the opposite side portion of the axle A is a flexible member or chain 21 which is secured to the rear beam 5 and at the end portion thereof remote from the connection 3 with which the member or chain 20 is engaged. These members or chains 20 and 21 serve to hold the ground working structure against undue lateral movement with respect to the portable structure.

Connecting the pole P and the arch of the axle A are the brace members 22. Extending outwardly and inwardly from an end portion of the axle structure A is an arm 23. Rotatably disposed through the outer extremity of the arm 23 is an elongated shank 24 provided at its upper end portion with an operating crank 25. Threaded upon the shank 24 is a nut or block 26 to which is secured the flexible members or chains 27. The members or chains 27 are also secured to the adjacent side beam 2 so that, upon rotation of the shank 24 in one direction, the block or nut 26 will be caused to move upwardly whereby the road working structure may be inclined in a direction transversely of its travel and in accordance with the slope which it may be desired to produce.

Interposed between the brace members 22 and the opposite end portion of the axle A are the additional brace or strengthening members 28.

Partially overlying the forward face of each of the members 4 is an elongated scraping blade 29 preferably of thin metal and which, when in applied position, has its lower portion extending below the lower edge of the associated member 4. The blade 29 is of a length substantially coextensive in length with the member 4 to which it is applied and may be readily reversed edge for edge and end for end whereby the life of said blade may be materially prolonged.

The blade 29, as herein disclosed, is maintained in applied position by the bolts 30 extending through the blade 29 and the member 4 and by the clips or hook members 31 overlying the upper marginal portions of the blade 29. Each of the clips or hook members 31 is provided at the end of an elongated shank 32 which is disposed through the member 4 and the associated beam 5 and coacting with said shank 32 and the rear face of the beam 5 is a clamping nut 33.

Secured to and depending from the pole

P is a block 34. To the under face of the block 34 is operatively engaged a whiffletree 35, to the opposite end portions of which are engaged the singletrees 36. The whiffletree 5 35 is secured to the block 34 by the bolt 37 or the like whereby said whiffletree is capable of swinging movement. Also secured to the block 34 by the bolt 37 is a draft bar 38, which bar 38 has its opposite end portion engaged with the forward beam 5 to 10 one side of the longitudinal center of said beam. The connection between the bar 38 and the forward beam 5 is adjustable lengthwise of the beam and which adjustment is 15 afforded by the longitudinally spaced openings 39 produced in said beam 5.

By means of the block 34 and the draft bar 38, the pull is direct upon the ground working structure and which is of material 20 advantage and benefit in an apparatus of this type. By adjusting the connection of the draft bar 38 longitudinally of its associated beam 5, the incline or slant of the members 4 may be regulated or adjusted 25 and which may also be accomplished by adjusting the connection of the beams 7 and 10. The adjustment of the draft bar 38, however, may be employed to cause the ends of the members 4 and the blades 29 carried 30 thereby to extend one beyond the other so as to avoid, during a working operation, the formation of one large ridge.

The apparatus as herein disclosed embodies a machine of light design capable of 35 being hauled easily by two horses and which embodies the combination of a scraper, road drag and leveler. It is to be noted that the portable structure as comprised in the axle A and the wheels W and the parts directly 40 associated therewith does not generally support the ground working structure except partially supporting the same when working in soft ground or particularly in rough ground and that the portable structure at no 45 time adds its weight to the ground working structure. An essential purpose of the portable structure is to prevent side motion of the ground working structure and which object is obtained through the instrumentality 50 of the cross chains 20 and 21. These chains however permit free action of the ground working structure.

Another particular feature of advantage in the present invention resides in the use 55 of the three blades 29 and the structure associated therewith as this arrangement permits the apparatus or machine to operate as a leveler. With the use of only two blades it will be readily seen that the rear or hind 60 blade will follow the front blade into a depression and make the roadway what is known as wavy. With the use of the three blades spaced apart as herein disclosed, when the apparatus or machine reaches a depression, the first blade 4 is prevented from drop-

ping into the depression because of the second blade being on higher ground. The forward blade will drop the dirt in the depression and under general conditions will reach the higher ground beyond 70 the depression in time to prevent the second or intermediate blade 4 from entering the depression. The weight of the ground working structure on the first and last blades 4 will cause the last blade to dig deep before 75 reaching the depression and its load will be deposited due to the rising position of the second blade. The three blade feature, as demonstrated in actual practice, reduces to a minimum the unevenness in roadways by 80 filling depressions and preventing the undulations usually found in roads dragged by the ordinary one or two blade machines or apparatus.

From the foregoing description it is 85 thought to be obvious that a road working apparatus constructed in accordance with my invention is particularly well adapted for use by reason of the convenience and facility with which it may be assembled and 90 operated, and it will also be obvious that my invention is susceptible of some change and modification without departing from the principles and spirit thereof and for 95 this reason I do not wish to be understood as limiting myself to the precise arrangement and formation of the several parts herein shown in carrying out my invention in practice except as hereinafter claimed.

I claim:

1. A road working machine comprising 100 a supporting structure including an axle carrying ground engaging wheels and secured to a draft tongue, and a ground engaging member formed as a frame including 105 spaced parallel side bars arranged outwardly of said wheels, obliquely arranged bars connected with said side bars, blades carried by said obliquely arranged bars, 110 braces connecting the successive oblique bars, a draft link pivotally connected with the tongue and with the forwardmost oblique bar, a plurality of flexible members secured at different points on the ground engaging member and connected with the tongue for 115 preventing lateral displacement of the ground engaging member with the supporting structure, and means on the axle for raising or lowering either side of the ground 120 engaging member.

2. A road working machine comprising 125 a supporting structure including an axle carrying ground engaging wheels and secured to a draft tongue, and a ground engaging member formed as a frame including 130 spaced parallel side bars arranged outwardly of said wheels, obliquely arranged bars connected with said side bars, blades carried by said obliquely arranged bars, braces connecting the successive oblique 135

bars, a draft link pivotally connected with the tongue and with the forwardmost oblique bar, a plurality of flexible members secured at different points on the ground engaging member and connected with the tongue for preventing lateral displacement of the ground engaging member with the supporting structure, and means on the axle for raising or lowering either side of the ground engaging member, the means at one side including an angular bracket rising from the axle, a threaded rod passing through said bracket and equipped with a handle, and a nut flexibly connected with one side bar and engaged upon said rod.

In testimony whereof I hereunto affix my signature.

JOHN J. MARTIN.