



(22) Date de dépôt/Filing Date: 2001/05/28

(41) Mise à la disp. pub./Open to Public Insp.: 2002/11/28

(51) Cl.Int.<sup>7</sup>/Int.Cl.<sup>7</sup> B67D 1/08, F21V 33/00

(71) Demandeur/Applicant:  
ANDERSON, GEORGE, CA

(72) Inventeur/Inventor:  
ANDERSON, GEORGE, CA

(74) Agent: KERR, JAMES W.

(54) Titre : MONTANT DE DISTRIBUTEUR DE BOISSONS AYANT UN AFFICHAGE LUMINEUX  
(54) Title: BEVERAGE DISPENSE STANCHION HAVING AN ILLUMINATED DISPLAY

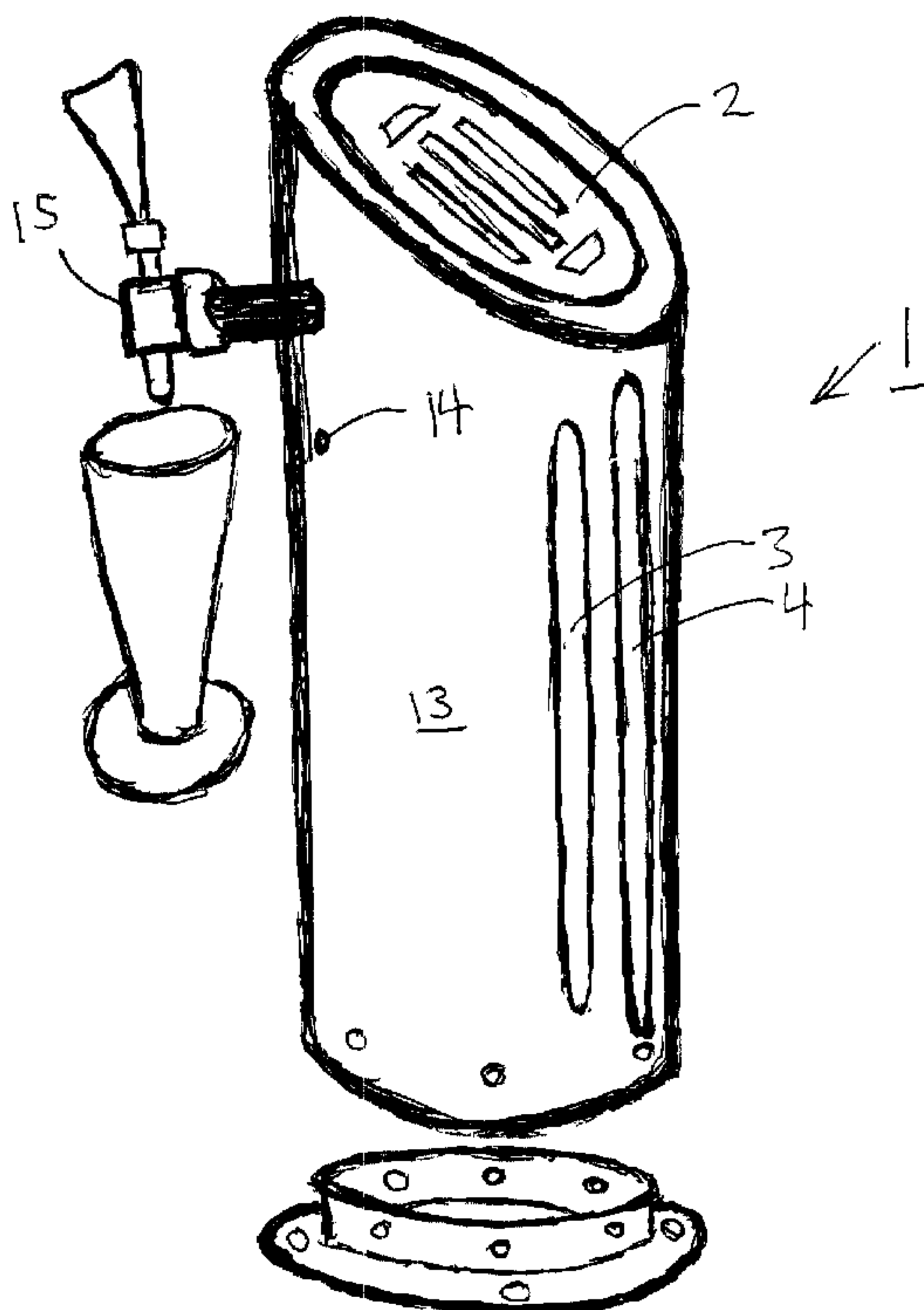

(57) Abrégé/Abstract:

A beverage dispense stanchion has an illuminated display unit which in turn includes a light guide with at least one connected light source. The light guide is operable to distribute light from the light source to enhance the display. The light guide is a decorative photoconductive body having a display surface and an edge into which the light source is fitted to illuminate the photoconductive body. The light source is a light emitting diode that is optically coupled into the edge, to diffuse light through the photoconductive body and thereby provide indirect lighting of the display surface. At least some non-display surface portion of the photoconductive body is adapted to reflect light back into the photoconductive body. The stanchion includes a carcass adapted for removable mounting of the illuminated display thereon, and ones of a plurality of interchangeable illuminated displays are adapted to be selectively mounted/removed from the carcass from time to time.

Beverage Dispense Stanchion having an Illuminated DisplayAbstract:

A beverage dispense stanchion has an illuminated display unit which in turn includes a light guide with at least one connected light source. The light guide is operable to distribute light from the light source to enhance the display. The light guide is a decorative photoconductive body having a display surface and an edge into which the light source is fitted to illuminate the photoconductive body. The light source is a light emitting diode that is optically coupled into the edge, to diffuse light through the photoconductive body and thereby provide indirect lighting of the display surface. At least some non-display surface portion of the photoconductive body is adapted to reflect light back into the photoconductive body. The stanchion includes a carcass adapted for removable mounting of the illuminated display thereon, and ones of a plurality of interchangeable illuminated displays are adapted to be selectively mounted/removed from the carcass from time to time.

Field of the Invention:

The present invention relates generally to beverage dispenser stanchions, and more particularly to stanchions having illuminated displays attached thereto.

Background of the Invention:

According to Canadian Patent Application 2,268,498, "most beverage dispenser stanchions are of relatively simple construction, and not pleasing to the eye". It is true that many, if not most stanchions, (like those used in the dispense of so-called "draft beer"), are often little more than simple cylindrical metal carcasses with a dispense tap attached thereto. Nevertheless, these have the merit of being relatively inexpensive, easy to clean and durable.

Bar and restaurant owners, however, also understand the need to provide their customers with a social experience that goes beyond mere provision of food and drink. These considerations certainly should extend to offering visual interest, venue-appropriate decor, and a choice-facilitating display that is indicative of currently available brand selection. Notwithstanding these considerations, the relative merits of the simple carcasses mentioned above, coupled with the reluctance of the owners to invest in more decorative stanchions that could become dated/obsolete (e.g. with changes in product graphics, color schemes in the décor, the proffering of brand selection), are significant barriers to the production, purchase and use of decorative beverage dispense stanchions.

Accordingly, there remains a need in the art for inexpensive (from both capital and operating cost perspectives), durable, illuminated beverage stanchions which provide for displays that can be interchanged to meet changes in décor and brand selections or updated graphics. Preferably, the illumination should provide for high luminosity with low heat generation (especially where the cold beverages are being dispensed), low energy consumption, and limited non-display "spill-over" of illumination into the ambient environment of the serving establishment. It would also be advantageous, if the illuminated display could be operated to advantage in a setting of diminished ambient lighting (such as a "night club" atmosphere), but provide non-competing directed light sources that would facilitate a bar tenders dispensing of the beverage.

Summary of the Invention:

In accordance therefore, with the practice of the present invention, there is provided a beverage dispense stanchion comprising at least one illuminated display unit. That display unit includes a

light guide with at least one connected light source. In this combination, the light guide is operable to distribute light from an at least one light source to enhance the display.

In a generally preferred form of the present invention, the light guide is a decorative photoconductive body. The photoconductive body has a display surface and at least one lateral limiting edge surrounding some portion of that surface. This edge is fitted with a light source that is adapted to illuminate the photoconductive body.

In a particularly preferred embodiment, the light source is a light emitting diode that is optically coupled to the edge, to diffuse light through the photoconductive body and thereby provide indirect lighting of the display surface.

At least some non-display surface portion of the photoconductive body is preferably adapted to reflect light back into the photoconductive body. This has the advantage of both brightening the display, and goes some way towards avoiding "leakage" of light that is not cogently delivered through the display surface, into the ambient environment.

The stanchion preferably includes a stanchion carcass that is adapted for removable mounting of the illuminated display thereon. The versatility of this arrangement is particularly manifest through the use of interchangeable illuminated displays that can be selectively mounted and removed from the carcass from time to time.

#### Introduction to the Drawings:

Figure 1 is a partially exploded perspective view of a preferred embodiment of the present invention, depicting a beverage dispense stanchion comprising a plurality of illuminated display units, and other features associated with the present invention.

Figure 2 is cross-section through an typical illuminated display unit useful in the combination of the present invention.

#### Detailed Description of a Preferred Embodiment of the Present Invention:

Referring now to the drawings in general, there is illustrated an exemplary embodiment in which a beverage dispense stanchion, shown generally by reference numeral 1, comprises a plurality of illuminated display units 2, 3 and 4, each having a respective light guide 5 with at least one connected light source 6. Light guide 5 is operable to distribute light from the associated light source 6 (or a plurality thereof, not shown) to enhance the effect of the display.

In stanchion 1, light guide 5 is a decorative photoconductive body 7 which has a display surface 8 and at least one lateral limiting edge 9 that is fitted with light source 6 which operates to illuminate the photoconductive body 7. Light source 6 is a light emitting diode that is optically coupled to edge 9, to diffuse light through photoconductive body 7 and thereby provide indirect lighting of display surface 8. At least some non-display surface portion (in this case edge 9 and back surface 10) of photoconductive body 7 is adapted to reflect light back into the photoconductive body 7. Reflective tape 12 is adhered to surfaces 9 and 10 to facilitate this function.

Stanchion 1 includes a stanchion carcass 13 that is adapted for removable mounting of the illuminated displays 2, 3 and 4. The particular mounting is not important, and not illustrated. By way of example, and without limiting the generality of the foregoing, known mechanical brackets, springs or even removable adhesives can be variously employed to this purpose, as will be readily apparent to persons skilled in the art in light of the present specification. This facilitates the use of various ones, combinations or permutations of various interchangeable illuminated displays (not exemplified in the drawings) that adapted to be selectively mounted/removed from carcass 13 from time to time.

The stanchion further includes a light emitting diode 14 arranged in proximal “activity-lighting” relation to a dispense tap 15. Light emitting diode 14 is operable to selectively illuminate the pouring operation of a beverage. Preferably, light emitting diode 14 is selected to emit light of a color that enhances the presentation of the pouring operation. For example, when beer is dispensed the light emitting diode can be selected to emits an amber/yellow/golden light that complements a typical lager beer coloration.

Light emitting diodes and edge panel illuminating displays useful in the practice of the present invention, as well as ancillary display and control features, as well as power supplies are generally well known in the art – as exemplified variously in such references as US 5,448,843; US 4,903,172; WO 99/03086; US 5,276,591; and, US 5,027,258 – all of which are incorporated in their entirety herein, by reference. A preferred commercial supply of edge lighting displays and light emitting diodes are available from AVVA Light Corporation, #5, 6025 12<sup>th</sup> Street, South East, Calgary, Alberta, Canada, T2H 2K1.

## Claims:

1. A beverage dispense stanchion comprising at least one illuminated display unit having a light guide with at least one connected light source, and wherein the light guide is operable to distribute light from an at least one light source to enhance the display.
2. The stanchion according to claim 1, wherein said light guide is a decorative photoconductive body having a display surface and at least one lateral limiting edge fitted with a light source that is adapted to illuminate the photoconductive body.
3. The stanchion according to claim 2 wherein said light source is a light emitting diode that is optically coupled to said edge, to diffuse light through said photoconductive body and thereby provide indirect lighting of said display surface.
4. The stanchion according to claim 3 wherein at least some non-display surface portion of said photoconductive body is adapted to reflect light back into the photoconductive body.
5. The stanchion according to claim 1, wherein said stanchion includes a stanchion carcass adapted for removable mounting of said illuminated display thereon.
6. The stanchion according to claim 5, further comprising a plurality of interchangeable illuminated displays adapted to be selectively mounted/removed from said carcass from time to time.
7. The stanchion according to claim 1, wherein a light emitting diode is provided in proximal activity lighting relation to a dispense tap, and is operable to selectively illuminate the pouring operation of a beverage.
8. The stanchion according to claim 7, wherein the light emitting diode is selected to emit light of a color that enhances the presentation of the pouring operation.
9. The stanchion according to claim 8, wherein beer is dispensed and the light emitting diode emits an amber/yellow/golden light.

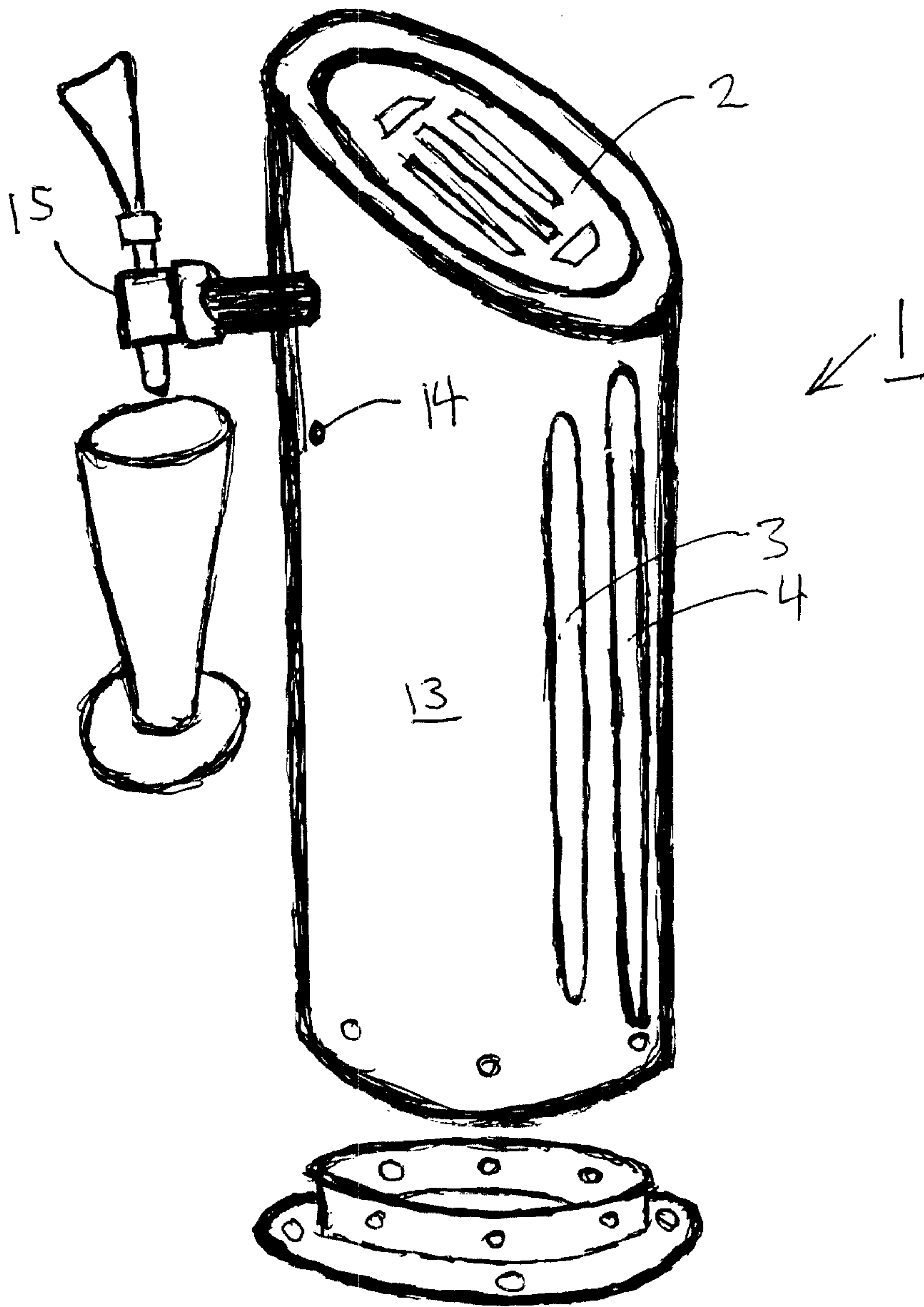

FIGURE 1

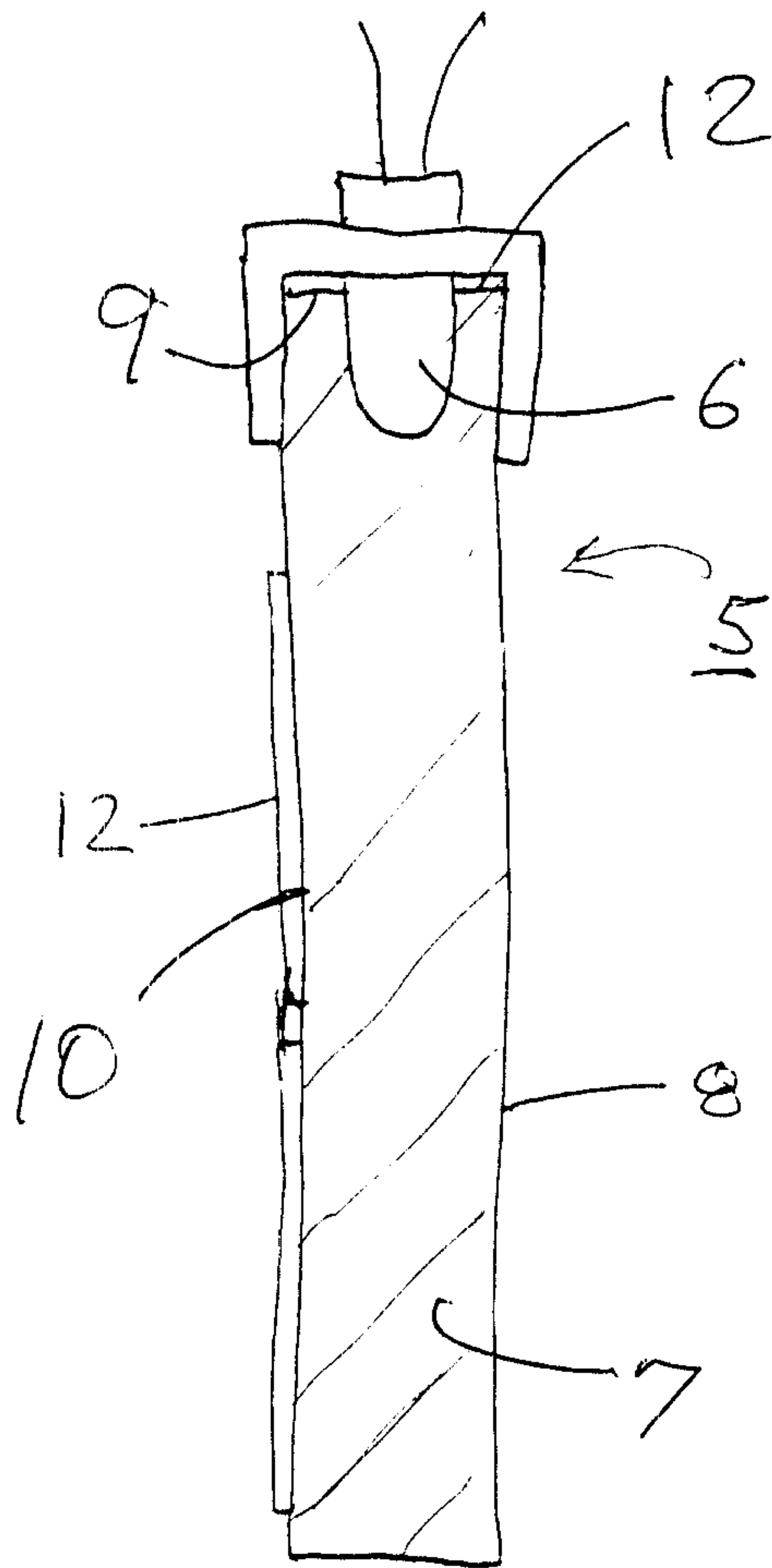

FIGURE 2

