

No. 694,276.

Patented Feb. 25, 1902.

W. M. HICKOK.
RAILROAD CONSTRUCTION.

(Application filed Dec. 2, 1901.)

(No Model.)

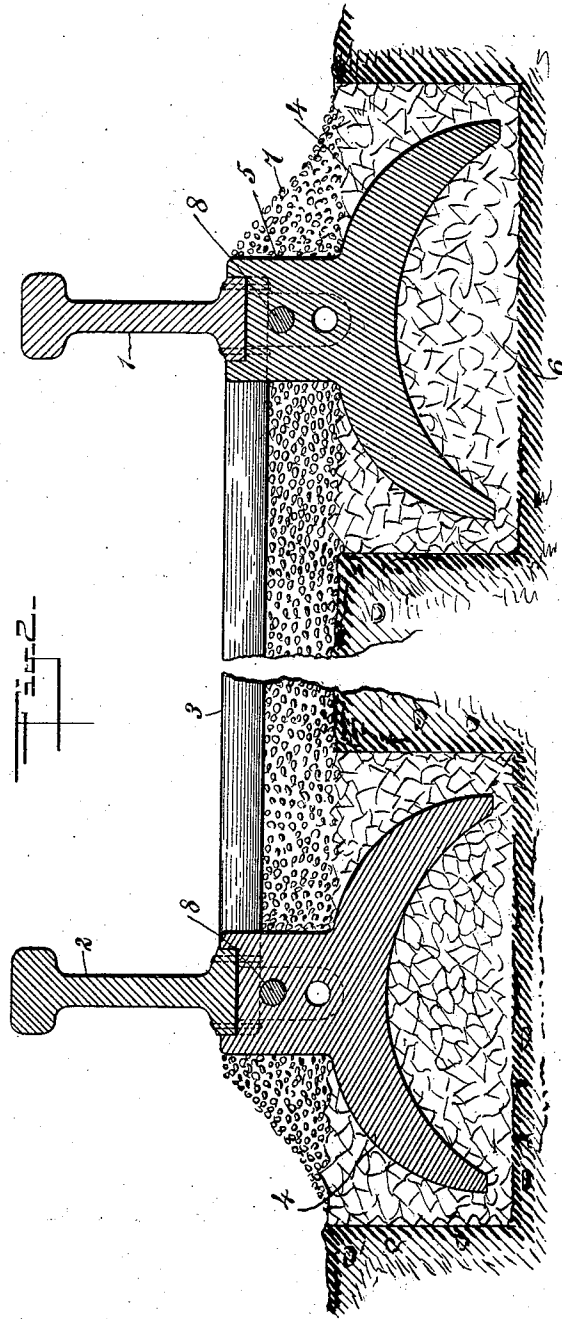
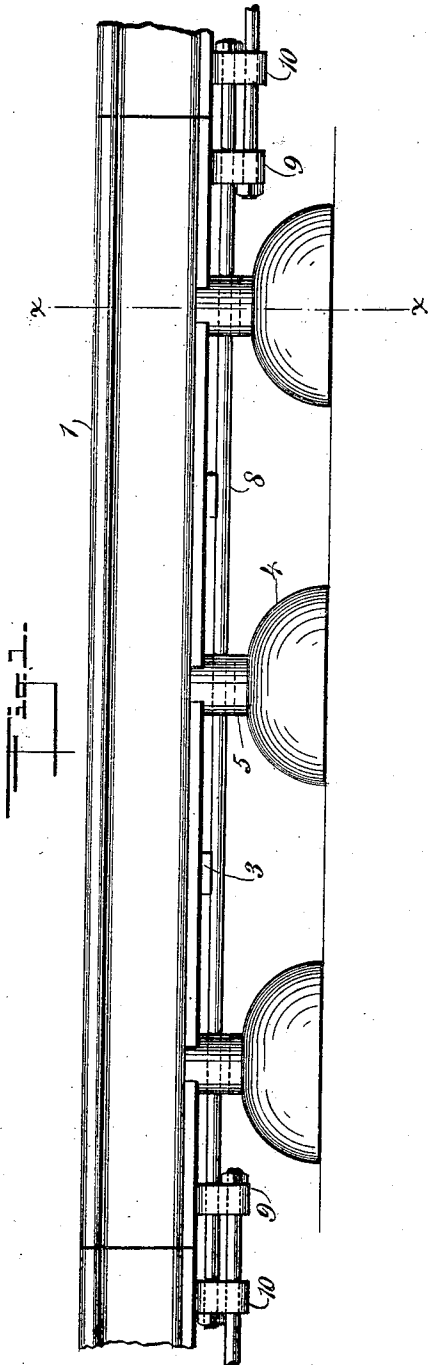

WITNESSES:

Russell Bond
C. R. Ferguson

INVENTOR

William M. Hickok

BY

Munn
ATTORNEYS

UNITED STATES PATENT OFFICE.

WILLIAM M. HICKOK, OF PHARISBURG, OHIO.

RAILROAD CONSTRUCTION.

SPECIFICATION forming part of Letters Patent No. 694,276, dated February 25, 1902.

Application filed December 2, 1901. Serial No. 84,360. (No model.)

To all whom it may concern:

Be it known that I, WILLIAM M. HICKOK, a citizen of the United States, and a resident of Pharisburg, in the county of Union and State of Ohio, have invented a new and Improved Railroad Construction, of which the following is a full, clear, and exact description.

This invention relates to improvements in the construction of railroads; and the object is to provide a construction whereby the rails will be held rigidly and in which the cost of building will be much less than that of a road as ordinarily built.

I will describe a railroad construction embodying my invention and then point out the novel features in the appended claims.

Reference is to be had to the accompanying drawings, forming a part of this specification, in which similar characters of reference indicate corresponding parts in both the views.

Figure 1 is a side elevation of a railroad construction embodying my invention, and Fig. 2 is a section on the line *xx* of Fig. 1.

Referring to the drawings, 1 2 designate the track-rails, which are connected at suitable intervals by cross-ties 3. The rails are also supported and held rigidly in place by anchor-plates 4. These anchor-plates are shown in the form of inverted cups and are provided with upwardly-extending portions 5, recessed at the top to receive the base of the rails. In Fig. 1 I have shown three anchor-plates as connected with the rail; but it is to be understood that more or less may be employed.

In building the road the anchor-plates are to be seated in the ground and placed with broken stone 6, over which a layer of gravel 7 is to be placed. For securing the abutting rails together I employ tie-rods 8, which extend through openings in the upwardly-extended portions 5 of the anchors and pass through openings in lugs 9 at the ends of one rail and through lugs 10 at the ends of the

adjacent rails. The tie-rods are provided with nuts for tightening purposes, and it will be noted in Fig. 1 that the lugs are provided with two openings, so that one tie-rod may pass through the upper openings and the next tie-rod pass through the lower openings.

A railroad embodying my invention will be held very rigid in the ground. It will be found particularly adapted for electric railways, as the tie-rods may be employed for the current, and, further, by employing the anchors, as shown, the railway cannot be tilted up from one side.

Having thus described my invention, I claim as new and desire to secure by Letters Patent—

1. In a railway construction, anchor-plates arranged at intervals along the rails, and tie-rods extended below and endwise of the rails and securing one rail to another, substantially as specified.

2. In a railroad construction, the inverted-cup-shaped plates having upward extensions provided with recesses to receive the base portions of rails, tie-rods extended through openings in said upwardly-extended portions, and lugs on the ends of the rails through which said rods pass, substantially as specified.

3. In a railroad construction, the track-rails, the cross-ties connecting opposite rails, anchor-plates arranged at intervals along the rails and secured thereto, and the tie-rods for connecting one rail with another, substantially as specified.

In testimony whereof I have signed my name to this specification in the presence of two subscribing witnesses.

WILLIAM M. HICKOK.

Witnesses:

J. L. THOMPSON,
N. D. DEGOOD.