



(51) International Patent Classification:

*H02B 1/06* (2006.01)      *H02B 11/12* (2006.01)  
*H02B 1/14* (2006.01)      *H05K 7/02* (2006.01)  
*H02B 1/26* (2006.01)      *H05K 7/16* (2006.01)

(21) International Application Number:

PCT/US2021/043080

(22) International Filing Date:

23 July 2021 (23.07.2021)

(25) Filing Language:

English

(26) Publication Language:

English

(30) Priority Data:

63/055,927      24 July 2020 (24.07.2020)      US

(71) Applicant: **SCHNEIDER ELECTRIC USA, INC.**

[US/US]; Boston One Campus, 800 Federal Street, AN-DOVER, Massachusetts 01810 (US).

(72) Inventors: **DOZIER, Steven Wayne**; Boston One Cam-

pus, 800 Federal Street, Andover, Massachusetts 01810

(US). **SUNDARAMOORTHY, Karthik**; Boston One

Campus, 800 Federal Street, Andover, Massachusetts 01810

(US). **TRAVIS, JR., Charles Wesley**; Boston One Cam-

pus, 800 Federal Street, Andover, Massachusetts 01810

(US). **O'NEILL, Daniel**; Boston One Campus, 800 Federal

Street, Andover, Massachusetts 01810 (US).

(74) Agent: **FILL, Peter** et al.; c/o Locke Lord LLP, PO Box

55874, Boston, Massachusetts 02205 (US).

(81) Designated States (*unless otherwise indicated, for every*

*kind of national protection available*): AE, AG, AL, AM,

AO, AT, AU, AZ, BA, BB, BG, BH, BN, BR, BW, BY, BZ,

CA, CH, CL, CN, CO, CR, CU, CZ, DE, DJ, DK, DM, DO,

DZ, EC, EE, EG, ES, FI, GB, GD, GE, GH, GM, GT, HN,

HR, HU, ID, IL, IN, IR, IS, IT, JO, JP, KE, KG, KH, KN,

KP, KR, KW, KZ, LA, LC, LK, LR, LS, LU, LY, MA, MD,

ME, MG, MK, MN, MW, MX, MY, MZ, NA, NG, NI, NO,

NZ, OM, PA, PE, PG, PH, PL, PT, QA, RO, RS, RU, RW,

SA, SC, SD, SE, SG, SK, SL, ST, SV, SY, TH, TJ, TM, TN,

TR, TT, TZ, UA, UG, US, UZ, VC, VN, WS, ZA, ZM, ZW.

(54) Title: IMPROVED CABLING DEVICE FOR ELECTRICAL DISTRIBUTION DEVICES

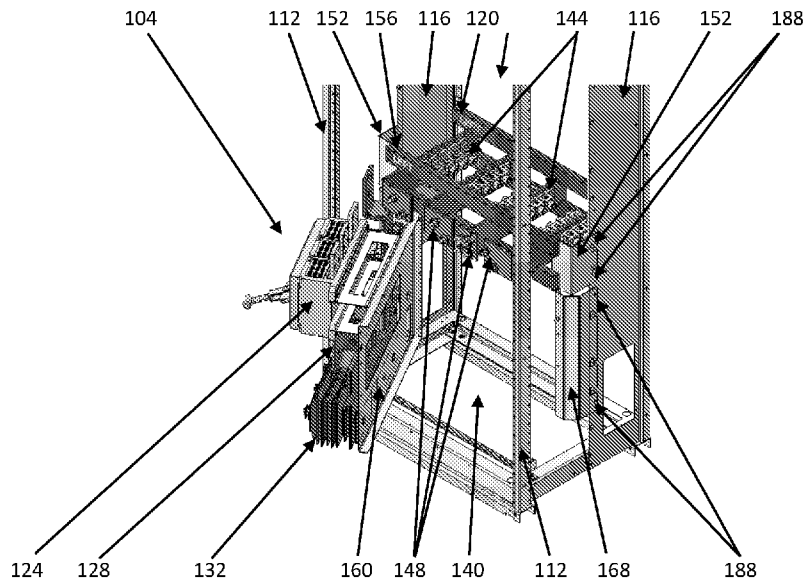

Figure 2

(57) Abstract: Embodiments provided herein are directed to an improved way to access and increase the area of an electrical distribution device provided for cable pulling and cabling. A rotatable section, on which several electrical components of the electrical distribution device are attached, can be rotated away from the cabling area as a single unit. This permits easier access to the cabling area and increases the size of the cabling area, which results in less time required to pull cables and wire the electrical components of the electrical distribution device.



**(84) Designated States** (*unless otherwise indicated, for every kind of regional protection available*): ARIPO (BW, GH, GM, KE, LR, LS, MW, MZ, NA, RW, SD, SL, ST, SZ, TZ, UG, ZM, ZW), Eurasian (AM, AZ, BY, KG, KZ, RU, TJ, TM), European (AL, AT, BE, BG, CH, CY, CZ, DE, DK, EE, ES, FI, FR, GB, GR, HR, HU, IE, IS, IT, LT, LU, LV, MC, MK, MT, NL, NO, PL, PT, RO, RS, SE, SI, SK, SM, TR), OAPI (BF, BJ, CF, CG, CI, CM, GA, GN, GQ, GW, KM, ML, MR, NE, SN, TD, TG).

**Published:**

— *with international search report (Art. 21(3))*

## IMPROVED CABLING DEVICE FOR ELECTRICAL DISTRIBUTION DEVICES

### RELATED CASE

[0001] The present application claims priority to U.S. provisional patent application serial no. 63/055,927, entitled MODULAR SWITCHBOARD, which was filed on July 24, 2020 and is incorporated herein in its entirety.

### TECHNICAL FIELD

[0001] The present disclosure relates to large electrical distribution devices having a main breaker/fused switch, and more particularly, to providing sufficient space for cabling and wiring the electrical distribution devices after they have been placed in their final location.

### BACKGROUND

[0002] Typically, when an electrical distribution device is delivered to a job site it is completely assembled and ready to be electrically connected to the utility power source and down-stream electrical distribution devices. Most of the components that require electrical connections are located behind the factory installed electrical components of the electrical distribution device, making the required electrical connections very difficult to complete.

### SUMMARY

[0003] One embodiment described herein provides an improved cabling device for an electrical distribution device. The improved cabling device includes a frame for supporting electrical components of the electrical distribution device. Additionally, the improved cabling device includes a rotatable section on which several of the electrical components of the electrical distribution device are

attached, the rotatable section being rotatably attached to the frame for rotation between two positions, in a first position access to a cabling area is restricted and in a second position access to the cabling area provided.

**[0004]** In one embodiment described herein, the electrical components of the electrical distribution device are located in front of the cabling area when the rotatable section is in the first position.

**[0005]** In one embodiment described herein, the electrical components attached to the rotatable section include a main breaker/fused switch, a load bus section and a through bus section.

**[0006]** In one embodiment described herein, the main breaker/fused switch must be electrically disconnected from a line bus section and the through bus section must be electrically disconnected from any adjacent through bus sections prior to rotating the rotatable section from its first position to its second position.

**[0007]** In one embodiment described herein, the main breaker/fused switch, load bus section and through bus section remain electrically connected when the rotatable section is in either of the first or second positions.

**[0008]** In one embodiment described herein, the rotatable section is maintained in each of the first and second positions by a single pivotal latch.

**[0009]** In one embodiment described herein, the rotatable section is attached to a first fixed section by a hinge, the first fixed section defining a hole adjacent to the hinge for receiving one end of the pivotal latch as the rotatable section is being rotated from its first position to its second position.

**[0010]** In one embodiment described herein, the pivotal latch has a notch which receives an edge of the hole defined in the first fixed section when the rotatable section has rotated to its second position, the notch preventing the rotatable section from moving until the pivotal latch has been lifted to disengage the edge of the hole.

**[0011]** Another embodiment described herein provides an improved cabling access device for an electrical distribution device. The cabling access device includes a frame assembly for supporting components of the electrical distribution device including the improved cabling access device. Additionally, the cabling access device includes a line bus section configured to electrically connect to a utility power source and further configured to electrically connect to a power disconnect device such as a circuit breaker or fused switch. The cabling access device further includes a load bus section configured to be electrically connected to the power disconnect device and further configured to be electrically connected to a through bus section. The through bus section provides an electrical connection to a through bus of an adjacent electrical distribution device. The cabling access device also includes a rotatable subframe on which the power disconnect device, load bus and through bus sections are attached. The rotatable subframe is attached to the electrical distribution device frame assembly by a hinge such that when the power disconnect device is electrically disconnected from the line bus section and the through bus section is electrically disconnected from the through bus of an adjacent electrical distribution device the rotatable subframe can be rotated such that a cabling area of the electrical distribution device is exposed permitting improved access for pulling and connecting electrical cables.

**[0012]** In one embodiment described herein, the rotatable subframe includes a first fixed section and a second fixed section, each being temporally attached to the frame during assembly by double headed rivets received in an L-shaped slots and permanently attached to the frame by screws.

**[0013]** In one embodiment described herein, the frame includes opposed side walls.

## BRIEF DESCRIPTION OF THE DRAWINGS

**[0014]** Figure 1 illustrates a front view of the improved cabling device in its closed position, according to one embodiment described herein.

[0015] Figure 2 illustrates an elevated corner view of the improved cabling device in its open position, according to one embodiment described herein.

[0016] Figure 3 illustrates an installed improved cabling device with the line bus section and main breaker/fused switch removed, according to one embodiment described herein.

[0017] Figure 4 illustrates an oblique view of the installed improved cabling device, according to one embodiment described herein.

[0018] A more detailed description of the disclosure, briefly summarized above, may be had by reference to various embodiments, some of which are illustrated in the appended drawings. While the appended drawings illustrate select embodiments of this disclosure, these drawings are not to be considered limiting of its scope, for the disclosure may admit to other equally effective embodiments.

[0019] Identical reference numerals have been used, where possible, to designate identical elements that are common to the figures. However, elements disclosed in one embodiment may be beneficially utilized on other embodiments without specific recitation.

## DETAILED DESCRIPTION

[0020] Referring now to Figures 1-4, an electrical distribution device **100** with an improved cabling device **104** installed is shown. The electrical distribution device **100** includes a frame **108** having uprights **112** and opposed side walls **116**, a line bus section **120**, a main breaker/fused switch **124**, a load bus section **128** and a through bus section **132**. When these particular sections are assembled they form a switchboard main section **136**.

[0021] As shown in the frontal view depicted in Figure 1, access to a cabling area **140** (Figure 2) located behind the main breaker/fused switch **124**, load bus section **128** and through bus section **132** is restricted. In the cabling area **140**

cables (not shown) from the utility supplying power to the switchboard main section **136** are pulled from raceways or conduit in the floor, walls or ceiling and connected to the cable lugs **144** (Figure 2) attached to line bus busbars **148**. The line bus section **120** is securely attached to the opposed side walls **116** by line bus brackets **152** and a line bus subframe **156**. The main breaker/fused switch **124**, load bus section **128** and through bus section **132** are attached to a rotatable section **160** of improved cabling device **104**.

[0022] The improved cabling device **104** includes a first fixed section **164** and a second fixed section **168**, which can be temporally attached to the opposed side walls **116** by L-shaped slots **172** which receive a double headed rivet **176** and securely attached to the side walls **116** by screws **196**. The first fixed section **164** is securely attached to one of the opposed side walls **116** along one side and attached by a hinge **180** to the rotatable section **160** along its other side.

[0023] In some applications the hinge **180**, or other known mechanisms for permitting rotation of an attached device, could also be attached to a structural member of the frame **108**, such as one of the uprights **112** or the side walls **116**. The second fixed section **168** is securely attached to the other of the opposed side walls **116**.

[0024] When cabling is required the main breaker/fused switch **124** is electrically disconnected from the line bus busbars **148** and the through bus section **132** is electrically disconnected from any adjacent through bus sections **132**. After the main breaker/fused switch **124** through bus section **132** have been disconnected a pivotal latch **184** (Figure 3) engaging the second fixed section **168** must be released to allow rotation of the rotatable section **160**. Additionally, as shown in Figure 3, the improved cabling device **104** includes a structural support member **190**, positioned below the first fixed section **164**. Generally, the structural support member **190** provides load bearing support for the rotatable section **160** and, for example, can assist in preventing the rotatable section **160** from sagging during rotation.

[0025] When the rotatable section **160** starts rotating the other end of the pivotal latch **184** enters a hole **188** in the first fixed section **164**. When the rotatable section **160** has rotated about 90 degrees a notch **192** in the pivotal latch **184** engages an edge of the hole **188** in the first fixed section **164** to keep the rotatable section **160** from moving while cabling is being done.

[0026] In the preceding, reference is made to various embodiments. However, the scope of the present disclosure is not limited to the specific described embodiments. Instead, any combination of the described features and elements, whether related to different embodiments or not, is contemplated to implement and practice contemplated embodiments. Furthermore, although embodiments may achieve advantages over other possible solutions or over the prior art, whether or not a particular advantage is achieved by a given embodiment is not limiting of the scope of the present disclosure. Thus, the preceding aspects, features, embodiments and advantages are merely illustrative and are not considered elements or limitations of the appended claims except where explicitly recited in a claim(s).

[0027] It is to be understood that the above description is intended to be illustrative, and not restrictive. Many other implementation examples are apparent upon reading and understanding the above description. Although the disclosure describes specific examples, it is recognized that the systems and methods of the disclosure are not limited to the examples described herein but may be practiced with modifications within the scope of the appended claims. Accordingly, the specification and drawings are to be regarded in an illustrative sense rather than a restrictive sense. The scope of the disclosure should, therefore, be determined with reference to the appended claims, along with the full scope of equivalents to which such claims are entitled.

## WE CLAIM:

1. An improved cabling access device for an electrical distribution device comprising:
  - a frame for supporting electrical components of the electrical distribution device;
  - a rotatable section on which several of the electrical components of the electrical distribution device are attached, the rotatable section being rotatably attached to the frame for rotation between two positions, in a first position access to a cabling area is restricted and in a second position access to the cabling area provided.
2. The improved cabling access device of claim 1, wherein the electrical components of the electrical distribution device are located in front of the cabling area when the rotatable section is in the first position.
3. The improved cabling access device of claim 1, wherein the electrical components attached to the rotatable section include a main breaker/fused switch, a load bus section and a through bus section.
4. The improved cabling access device of claim 3, wherein the main breaker/fused switch must be electrically disconnected from a line bus section and the through bus section must be electrically disconnected from any adjacent through bus sections prior to rotating the rotatable section from its first position to its second position.
5. The improved cabling access device of claim 3, wherein the main breaker/fused switch, load bus section and through bus section remain electrically connected when the rotatable section is in either of the first or second positions.

6. The improved cabling access device of claim 1, wherein the rotatable section is maintained in each of the first and second positions by a single pivotal latch.
7. The improved cabling access device of claim 6, wherein the rotatable section is attached to a first fixed section by a hinge, the first fixed section defining a hole adjacent to the hinge for receiving one end of the pivotal latch as the rotatable section is being rotated from its first position to its second position.
8. The improved cabling access device of claim 7, wherein the pivotal latch has a notch which receives an edge of the hole defined in the first fixed section when the rotatable section has rotated to its second position, the notch preventing the rotatable section from moving until the pivotal latch has been lifted to disengage the edge of the hole.
9. The improved cabling access device of claim 1, further comprising:
  - a structural support member coupled to the frame and configured to provide load bearing support for the rotatable section.
10. An improved cabling access device for an electrical distribution device comprising:
  - a frame assembly for supporting components of the electrical distribution device including the improved cabling access device;
  - a line bus section configured to be electrically connected to a utility power source and further configured to be electrically connected to a power disconnect device such as a circuit breaker or fused switch;
  - a load bus section configured to be electrically connected to the power disconnect device and further configured to be electrically connected to a through bus section, the through bus section provides an electrical connection to a through bus of an adjacent electrical distribution device;
  - a rotatable subframe on which the power disconnect device, load bus and through bus sections are attached;

wherein the rotatable subframe is attached to the electrical distribution device frame assembly by a hinge such that when the power disconnect device is electrically disconnected from the line bus section and the through bus section is electrically disconnected from the through bus of an adjacent electrical distribution device the rotatable subframe can be rotated such that a cabling area of the electrical distribution device is exposed permitting improved access for pulling and connecting electrical cables.

11. The improved cabling access device of claim 10, wherein the rotatable subframe includes a first fixed section and a second fixed section, each being temporarily attached to the frame during assembly by double headed rivets received in an L-shaped slots and permanently attached to the frame by screws.

12. The improved cabling access device of claim 10, wherein the frame can include opposed side walls.

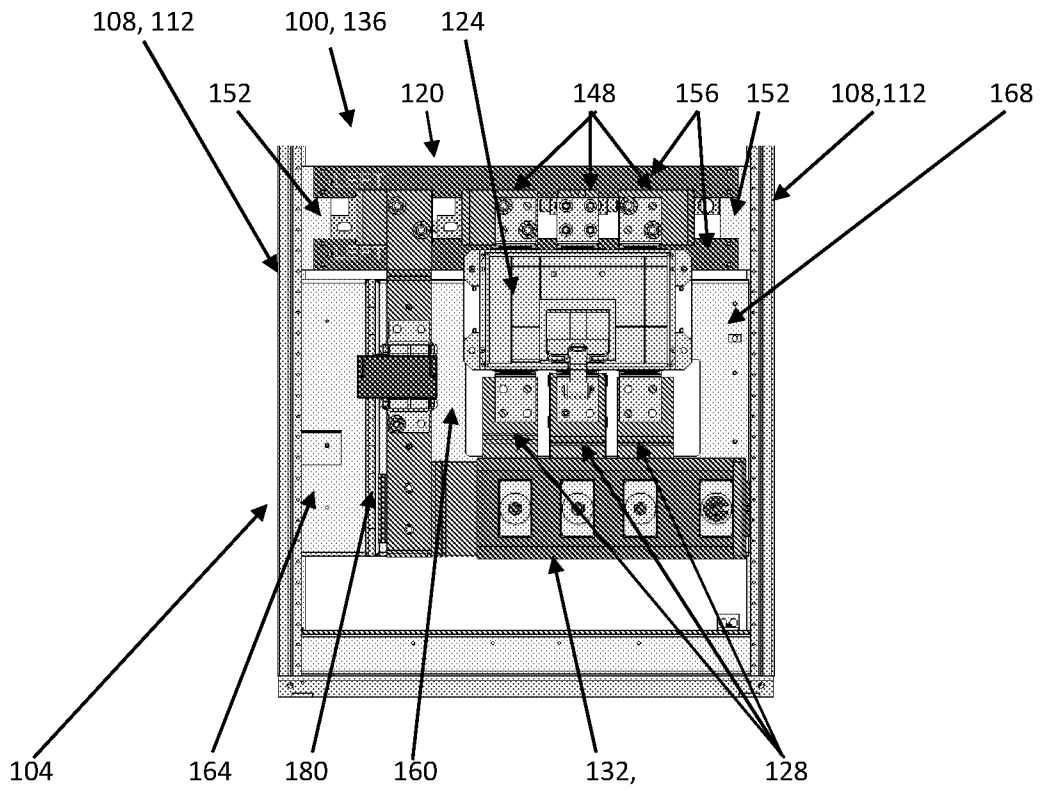

Figure 1

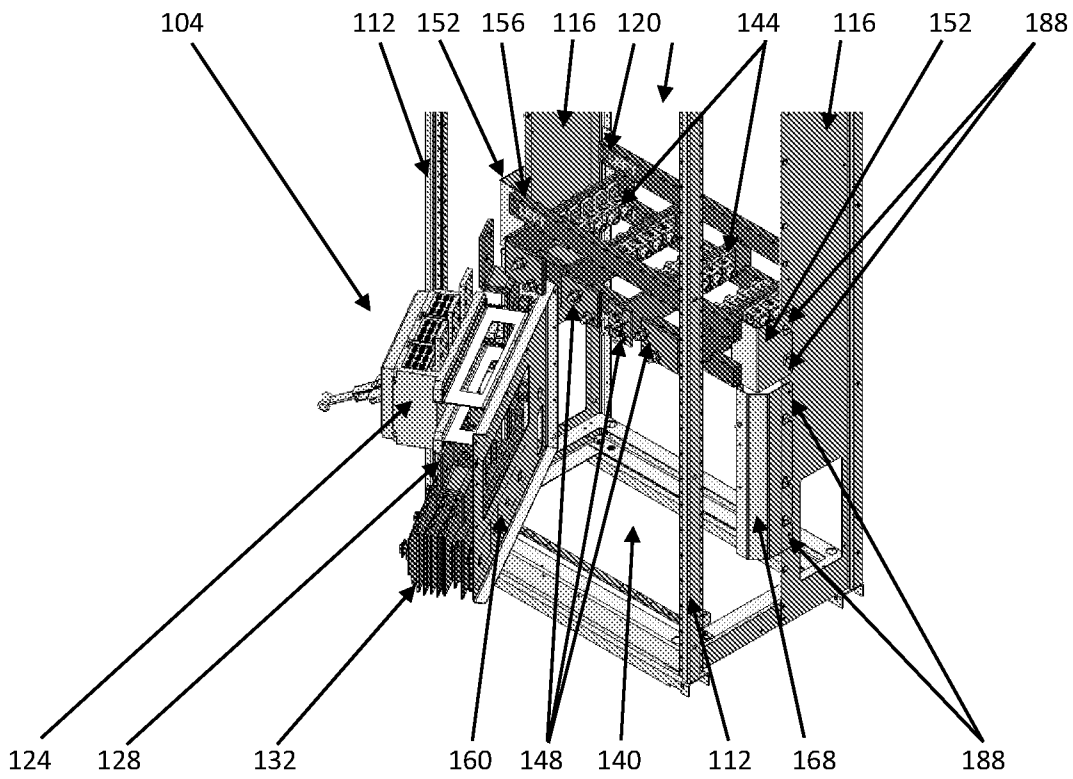

Figure 2

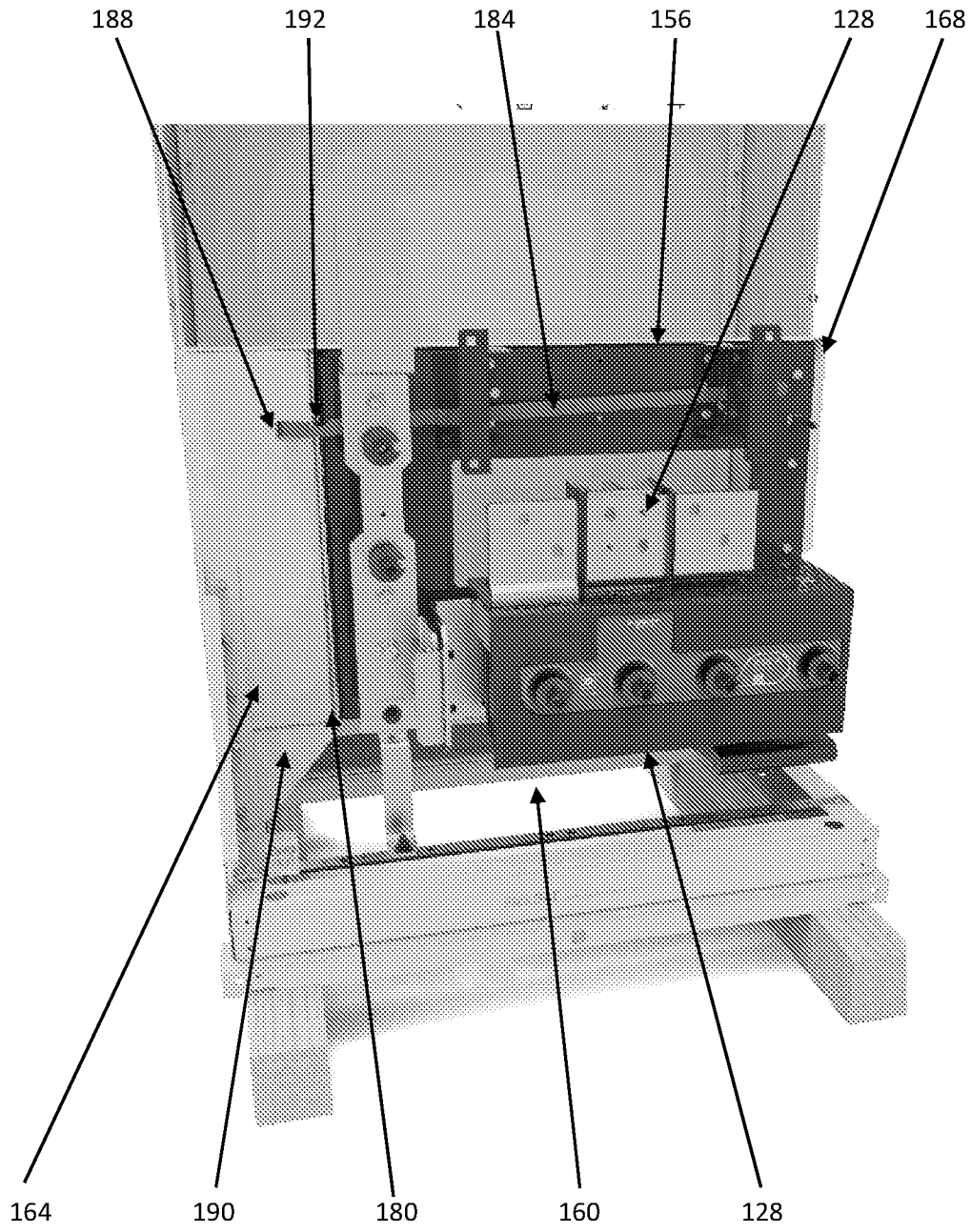

Figure 3

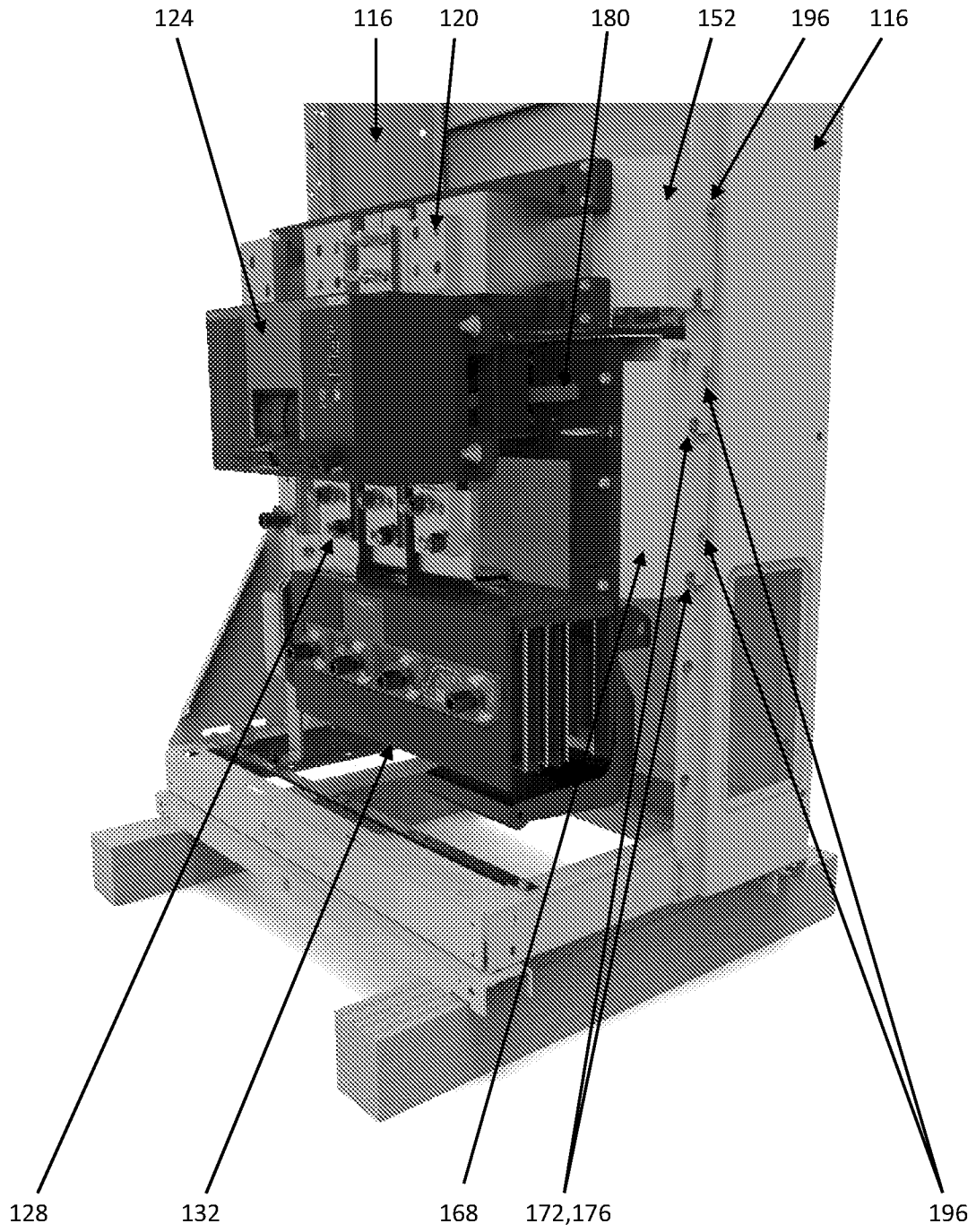

Figure 4

**INTERNATIONAL SEARCH REPORT**

International application No.  
PCT/US2021/043080

**A. CLASSIFICATION OF SUBJECT MATTER**

IPC(8) - H02B 1/06; H02B 1/14; H02B 1/26; H02B 11/12; H05K 7/02; H05K 7/16 (2021.01)  
CPC - H02B 1/06; H02B 1/14; H02B 1/26; H02B 11/00; H02B 11/02; H02B 11/12; H05K 7/00; H05K 7/02; H05K 7/14; H05K 7/16 (2021.08)

According to International Patent Classification (IPC) or to both national classification and IPC

**B. FIELDS SEARCHED**

Minimum documentation searched (classification system followed by classification symbols)  
see Search History document

Documentation searched other than minimum documentation to the extent that such documents are included in the fields searched  
see Search History document

Electronic data base consulted during the international search (name of data base and, where practicable, search terms used)  
see Search History document

**C. DOCUMENTS CONSIDERED TO BE RELEVANT**

Category*	Citation of document, with indication, where appropriate, of the relevant passages	Relevant to claim No.
X	DE 1769878 U (FERNSEH GMBH) 10 July 1958 (10.07.1958) machine translation	1, 2, 9
A	US 10,218,158 B1 (SIEMENS INDUSTRY, INC.) 26 February 2019 (26.02.2019) entire document	1-12
A	US 2016/0372895 A1 (EATON INDUSTRIES (AUSTRIA) GMBH) 22 December 2016 (22.12.2016) entire document	1-12

Further documents are listed in the continuation of Box C.       See patent family annex.

* Special categories of cited documents:	"T" later document published after the international filing date or priority date and not in conflict with the application but cited to understand the principle or theory underlying the invention
"A" document defining the general state of the art which is not considered to be of particular relevance	"X" document of particular relevance; the claimed invention cannot be considered novel or cannot be considered to involve an inventive step when the document is taken alone
"D" document cited by the applicant in the international application	"Y" document of particular relevance; the claimed invention cannot be considered to involve an inventive step when the document is combined with one or more other such documents, such combination being obvious to a person skilled in the art
"E" earlier application or patent but published on or after the international filing date	"&" document member of the same patent family
"L" document which may throw doubts on priority claim(s) or which is cited to establish the publication date of another citation or other special reason (as specified)	
"O" document referring to an oral disclosure, use, exhibition or other means	
"P" document published prior to the international filing date but later than the priority date claimed	

Date of the actual completion of the international search 29 September 2021	Date of mailing of the international search report <b>NOV 04 2021</b>
Name and mailing address of the ISA/US Mail Stop PCT, Attn: ISA/US, Commissioner for Patents P.O. Box 1450, Alexandria, VA 22313-1450 Facsimile No. 571-273-8300	Authorized officer  Harry Kim  Telephone No. PCT Helpdesk: 571-272-4300