

[54] **ELECTRICAL SWITCH DEVICES**

[75] Inventors: **Roger Daniel Lacrampe; Thierry Arnaud Henri Lacrampe**, both of Paris, France

[73] Assignee: **Sam Marcel Braun**, Paris, France; a part interest

[22] Filed: **Feb. 2, 1972**

[21] Appl. No.: **222,955**

[30] **Foreign Application Priority Data**

Feb. 19, 1971 France 7105665

[52] U.S. Cl. **335/187, 200/166 BD, 335/280**

[51] Int. Cl. **H01h 50/54**

[58] Field of Search **335/187, 280; 200/166 BD**

[56] **References Cited**

UNITED STATES PATENTS

3,086,094 4/1963 Ovshinsky 200/166 BD
 1,357,942 11/1920 Ballman 200/166 BD

1,215,423 2/1917 Spangler 200/166 BD

Primary Examiner—Harold Broome

Attorney—Alan H. Levine

[57] **ABSTRACT**

A switch device having at least two stationary contacts for connection in an electrical circuit and a movable contact or conductor element of spherical or other shape of circular cross-section such as a disc or cylinder. A movable blade extending between the stationary contacts is formed with a hole housing the element which is free to rotate about its centre axis. Movement of the blade in one direction brings the element into contact with both stationary contacts to make the circuit which is broken by the blade moving the element in the opposite direction. The element is rotated by the making and breaking movements so that deterioration of the element's curved periphery by wear and spark discharge is substantially prevented as different parts of the periphery come successively into contact with the stationary contacts.

6 Claims, 2 Drawing Figures

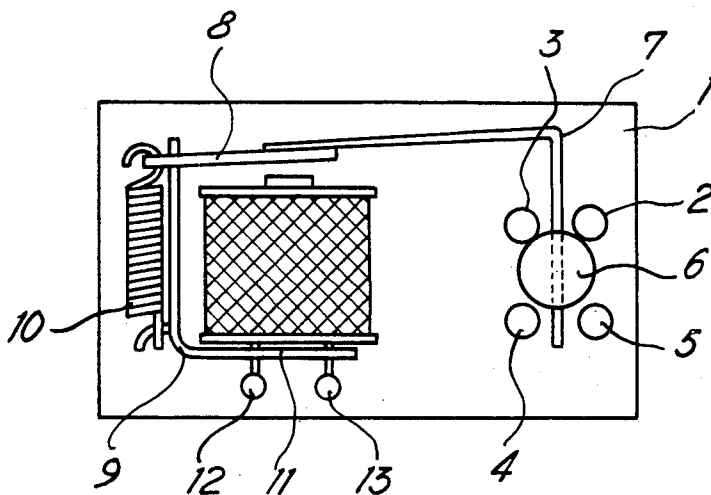

FIG. 1

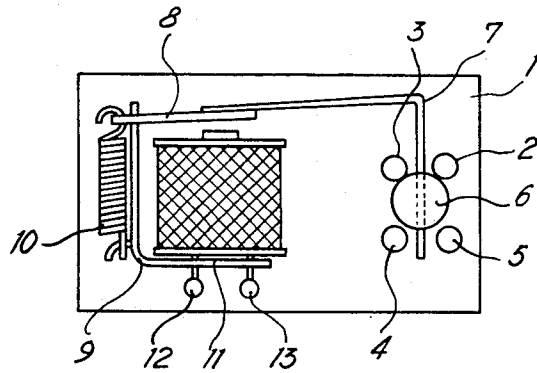
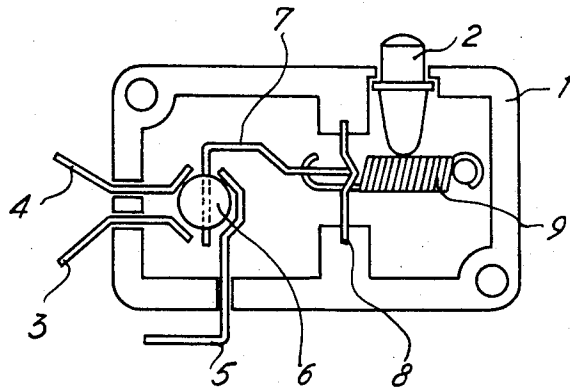

FIG. 2



ELECTRICAL SWITCH DEVICES

The present invention relates to instruments intended for establishing or interrupting electrical circuits.

In devices of this type, a moving blade or shutter comprises a riveted or mounted contact which bears against at least one stationary contact.

The contact of the moving shutter and the stationary contact(s) always takes place at the same point, which causes a rapid deterioration of the said contacts, due to the repeated occurrence of break sparks at this point, which can even cause the contacts to become welded.

An object of the invention is to provide a switch device in which the above disadvantages are overcome or at least mitigated.

According to the invention there is provided a switch device for connection to at least two separate points of an electrical circuit and for establishing or interrupting an electrical connection in a controlled manner between these two points, comprising two stationary contacts and a mobile short-circuit element capable of being brought into abutment against the two contacts by a control member, the short-circuit element being a body of rotation about an axis of symmetry and being mounted on the control member so as to be able to rotate about said axis.

In a switch device formed according to the invention the life of the contacts is increased and it is possible to forego the mounting or riveting of the contacts. This leads to simplification in manufacture and improves operating reliability of apparatus using the device.

In the switch device the short-circuit element is preferably made at least partially of precious metal, bearing against at least two stationary contacts and which, when current flows through it, establishes an electrical circuit. The displacement of the short-circuit element, produced by a mechanical control member, causes the interruption of the electrical circuit and possibly the closure of another circuit.

The short-circuit element may be a ball, a hollow sphere or a disk, preferably of precious metal.

The invention will now be further described with reference to the accompanying drawing which diagrammatically illustrates, by way of example, two embodiments of switch devices formed according to the invention.

FIG. 1 shows an electromagnetic relay which comprises a base 1 of insulating material to which are fixed stationary contacts 2, 3, 4, 5, a ball 6 which may be displaced between said stationary contacts. In order to do this, the ball is freely housed in a hole in a blade 7, fixed to a mobile shutter 8, itself pivoted on a magnetic circuit 9, the shutter 8 being drawn back by a spiral spring 10. A coil 11 which is supplied with current by terminals 12 and 13, creates the magnetic field which attracts the mobile shutter 8 which has the effect of causing the displacement of the ball 6 and of placing it in contact with the contacts 4 and 5 whereas before the coil 11 was supplied with current, the said ball was establishing contact between the contacts 2 and 3.

Tests have shown that for each operation of the relay thus constituted, the ball 6 rotates about itself and never or only infrequently establishes contact at the same point.

The free mounting of the ball also has the advantage of avoiding rebounds.

The displacement of the ball during each control operation prevents repeated heating at one point of the ball, as well as preventing localised wear and tear of its outer surface. In addition, the fact that a cold part of the ball touches the stationary contacts on each occasion, prevents repeated heating of these contacts and causes their cooling which reduces the wear and tear almost completely, since they operate cold and this increases their life.

FIG. 2 illustrates an embodiment of the present invention in the field of quick-break contactors. As it is illustrated, the device comprises an insulating casing 1 and its control button 2. There are also shown the stationary contacts 3, 4, 5 and the ball 6 which, in the stationary position, bears against the stationary contacts 4 and 5. At one end the mobile blade 7 has a hole in which the ball 6 is freely housed; its other end is supported at a joint 8 which is a so-called knife-joint. A spring 9, secured at one end to the insulating housing 1, is connected at its other end to the moving blade 7 and keeps the blade pressed against the knife joint 8. It is easy to understand that when pressure is applied to the button 2, the latter causes a disalignment of the spring 9 which produces a downwards displacement of the blade 7, which forces the ball 6 to make a contact between the stationary points 3 and 5, at the same time breaking the contact between the stationary contacts 4 and 5 and thus acts as a reversing switch.

In the case where the short-circuit element is a ball, the hole in the blade in which the ball is freely housed is not necessarily the same shape as that of the ball; it may advantageously be rectangular. In the case where the short-circuit element is a disk, it is preferable that the hole is rectangular.

It will be noted that the fixed contacts also form a lateral abutment in order to limit the displacement of the short-circuit element perpendicular to the blade during the displacement of the latter.

The device formed in accordance with the invention may be used in all cases where it is desired to establish or interrupt any electric circuit. Particularly advantageous applications may be in or as electromagnetic relays, contactors and micro-switches.

What is claimed is:

1. An actuatable electrical switch device comprising: a spherical body having at least its outer surface made of electrically conductive material; means, including a pair of electrical contacts, containing the spherical body, said body being movable within said containing means, a pair of opposed slots in said containing means, said pair of electrical contacts being located on opposite sides of at least one of the slots; and a single thin blade passing through said slots, said blade having an opening within which said spherical body is located, the edge of said opening being thin with respect to the diameter of said spherical body so that said body cannot be supported in a stable condition by said blade alone, and said single blade being the sole support for said spherical body when the latter is moving toward and away from said contacts, and actuating means for moving said blade, whereby electrical conduction between said contacts can be established or interrupted.
2. A switch, as defined in claim 1, comprising another pair of electrical contacts, each of the contacts being

3

4

located at opposite sides of the other one of said slots.

3. A switch as defined in claim 2, wherein said containing means comprises only said pairs of contacts, a pair of said contacts being electrically insulated.

4. A switch as defined in claim 1, wherein the actuating means comprises resilient means, a magnetic member secured to said blade, and an electromagnet driving

the magnetic member against the resilient means.

5. A switch as defined in claim 1 wherein said actuating means pivots said blade about an axis spaced from the path of movement of said blade.

6. A switch as defined in claim 1 wherein said contacts are stationary.

* * * * *

10

15

20

25

30

35

40

45

50

55

60

65