

July 24, 1951

W. S. COSTELLO
CUFF IRONING MACHINE

2,561,463

Filed June 2, 1949

4 Sheets-Sheet 1

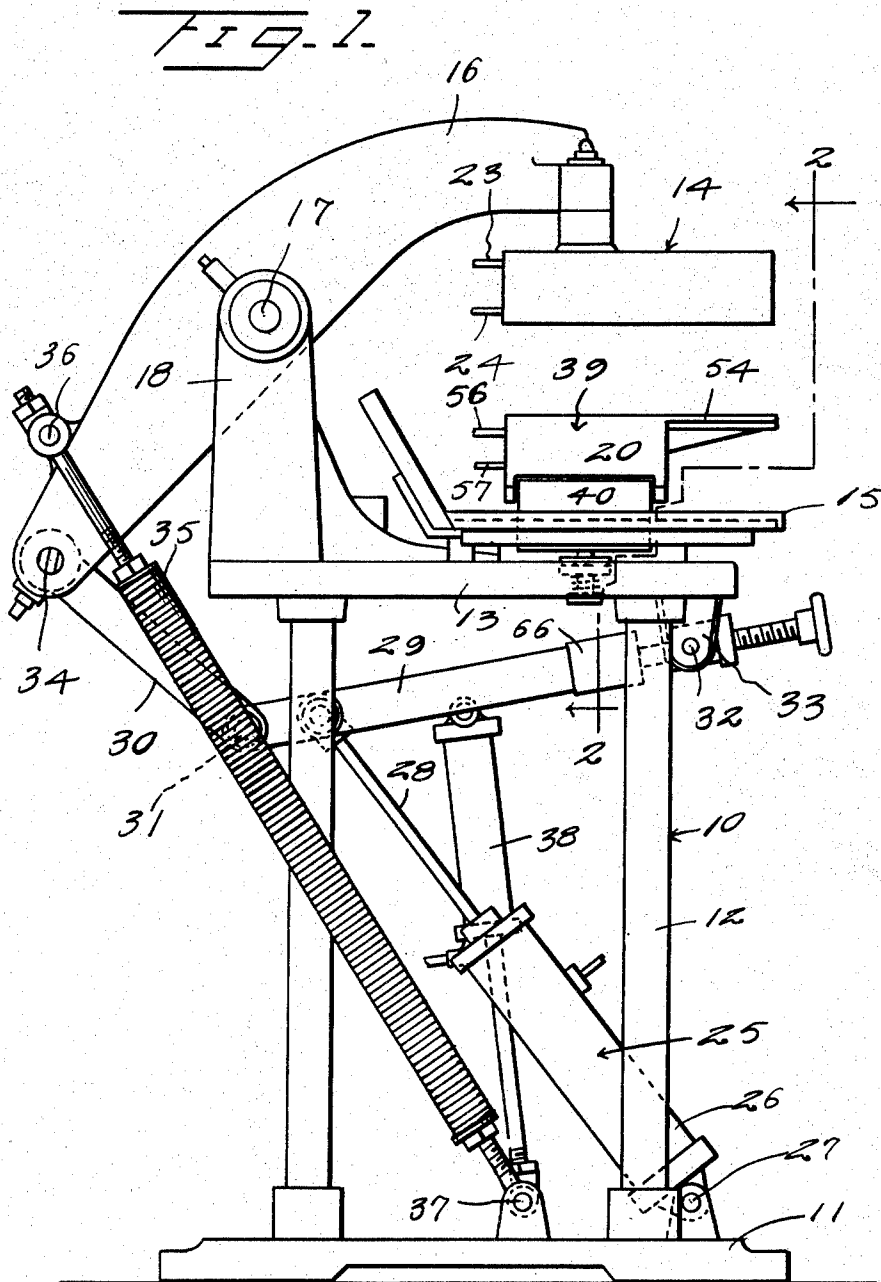

INVENTOR.
W.S. Costello
BY

Kimmel & Lowell ATTORNEYS

July 24, 1951

W. S. COSTELLO
CUFF IRONING MACHINE

2,561,463

Filed June 2, 1949

4 Sheets-Sheet 3

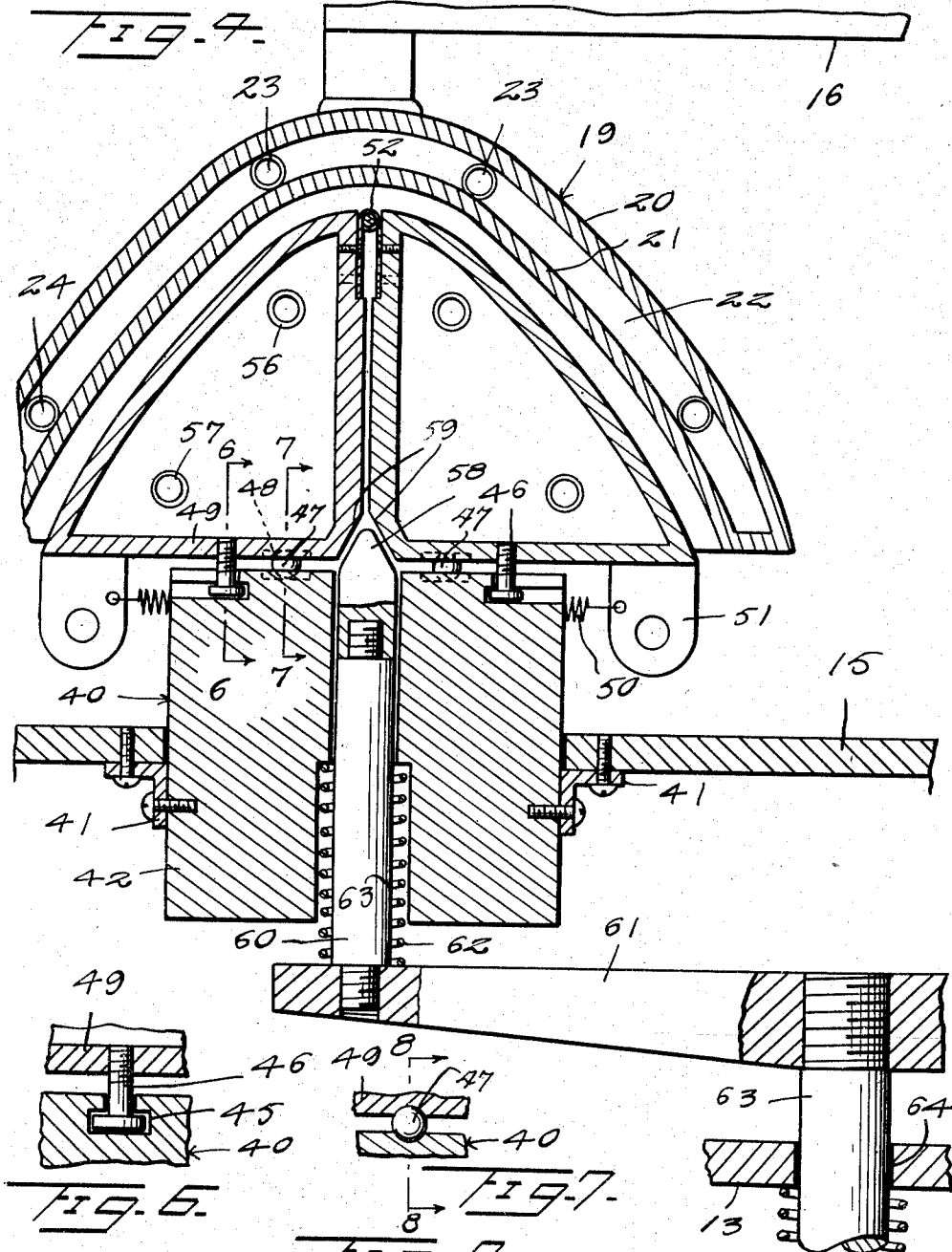

INVENTOR.
W.S. Costello
BY

Kimmel & Crowell ATTORNEYS

UNITED STATES PATENT OFFICE

2,561,463

CUFF IRONING MACHINE

William Stephenson Costello, Washington, D. C.

Application June 2, 1949, Serial No. 96,715

6 Claims. (Cl. 223—52.1)

1

This invention relates to a cuff pressing or ironing machine.

In ironing machines designed for use in ironing shirt cuffs, a stationary form is carried by a frame structure and a movable form of concave cross section is moved under air or liquid pressure down onto the stationary form. The two forms are steam heated, but it would appear that a smooth ironing of a cuff is hard to obtain particularly on the end carrying the button. It is, therefore, an object of this invention to provide an improved cuff ironer which will smoothly iron the cuff throughout the area of the cuff.

Another object of this invention is to provide an improved cuff ironer which can be produced as an attachment for an ironing machine.

A further object of this invention is to provide a cuff ironer wherein the lower ironer element is expansible so that when the upper element is pressed down onto the lower element, the latter element is partially expanded so as to place the cuff under increased pressure, particularly at the outer ends of the cuff.

A further object of this invention is to provide as an attachment for a cuff ironing machine, a pair of expansible members adapted to be secured to the frame of the machine beneath the movable ironing members, together with means disposed in the path of movement of the toggle actuating the movable members whereby the expansible members will be slightly expanded at the time the movable members are in their pressure applying position so that increased pressure will be applied to the cuffs.

With the above and other objects in view, my invention consists in the arrangement, combination and details of construction disclosed in the drawings and specification, and then more particularly pointed out in the appended claims.

In the drawings,

Figure 1 is a detail side elevation of a cuff ironing machine constructed according to an embodiment of this invention,

Figure 2 is a fragmentary sectional view taken on the line 2—2 of Figure 1,

Figure 3 is a plan view of the lower ironing members,

Figure 4 is a fragmentary transverse sectional view showing the upper press member in substantially operative position,

Figure 5 is a fragmentary sectional view taken on the line 5—5 of Figure 3,

Figure 6 is a fragmentary sectional view taken on the line 6—6 of Figure 4,

Figure 7 is a fragmentary sectional view taken on the line 7—7 of Figure 4,

2

Figure 8 is a fragmentary sectional view taken on the line 8—8 of Figure 7,

Figure 9 is a fragmentary sectional view taken on the line 9—9 of Figure 5.

Referring to the drawings, the numeral 10 designates generally a frame structure, including a base 11, uprights 12, and a top 13. An upper cuff pressing member generally designated as 14 is disposed above a table or platform 15 which is mounted on the top 13, and is pivotally connected to one end of a rock lever 16 which is rockably mounted on a shaft 17 extending between a pair of upstanding bearing mounting members 18. The bearing mounting members 18 extend upwardly from the top 13 adjacent the rear of the latter.

The upper press member 14 is formed of a pair of parabolic shaped hollow members 19, each formed of upper and lower walls 20 and 21 which are spaced apart and form a steam chest or heating chamber 22 therebetween. The press members 14 are adapted to be connected by means of steam lines 23 and 24 to a source of steam supply for circulating steam through the heating chamber 22.

The rock lever 16 is adapted to be rocked by means of a hydraulic operator generally designated as 25. The operator 25 includes a cylinder 25 which is pivoted as at 27 on the base 11, and has extending therefrom a piston rod or stem 28 which is pivotally connected at its upper end to one link 29 of a toggle link structure, including the link 29 and a second link 30. The two links 29 and 30 are pivotally connected together at 31 and the link 29 is pivotally mounted at 32 on a bearing or support 33 extending downwardly from the top 13. The link 30 is pivotally connected as at 34 to the lower end of lever 16.

A pair of elongated springs 35 are connected between the rear or lower portion of lever 16 as at 36, and the base 11, as indicated at 37 and constantly urge the lever 16 upwardly at its forward end to a released or inoperative position. A dashpot or cushioning member 38 is connected between toggle link 29 and the base 11, as shown in Figure 1 so as to cushion and retard the movement of lever 16 to an upper inoperative position.

A pair of lower cuff members generally designated as 39 are movably mounted on a base means 40 which is fixed by fastening means 41 to the table or platform 15. The base or support 40 includes a pair of spaced apart blocks 42 which extend partly below and partly above the table 15 and each lower press member 39 which comprises complementary members 43 and 44 is movably mounted on the upper side of the base 40.

3

The base 40 is provided, as shown in Figures 4 and 5, with a pair of inverted T-shaped slots 45 extending inwardly from the outer side thereof, and headed bolts 46 which are threaded into the lower sides of the lower press members 43 and 44 have the heads thereof loosely and slidably engaging in the slots 45.

A pair of balls 47 are interposed between the bottoms of the lower members 43 and 44 and the upper sides of the base members 42, being movably mounted in confronting recesses 48 which are formed in the lower wall 49 of each member 43 and 44 and in the upper side of the base member 40. A pair of springs 50 are connected between depending ears 51 carried by the opposite ends of the press members 43 and 44 and constantly urge these members toward each other at their lower ends.

The press members 43 and 44 are hingedly connected together by hinge means 52 engaging along the upper edges of the press members 43 and 44 and as shown in Figure 5 the press members 43 and 44 project forwardly at their forward ends as indicated at 53 and terminate in forwardly projecting extensions 54 which project forwardly from the upper extensions 53. A bracing web 55 is connected between the forward wall of a lower press member and the extensions 53 and 54. The press members 43 and 44 are hollow and have connected therewith steam pipes 56 and 57 adapted to be connected to a source of steam heating and pressure supply.

In order to provide a means whereby the press members 43 and 44 may be expanded a slight degree at the time the upper press member 19 is in its lower pressing and operative position, I have provided a wedge member 58 which is slidable between the base members 42 and is adapted to engage between tapered surfaces 59 formed at the lower inner portions of the two press members 43 and 44. The wedge or cam member 58 is carried by an upwardly extending stud 60 which is secured at its lower end to a crosshead 61. A spring 62 engages in a counterbore 63 which is formed between the base members 42 and bears against the crosshead 61 so as to constantly urge the crosshead 61 downwardly to inoperative position. The crosshead 61 has secured thereto a vertically disposed shaft 63 slidable through an opening 64 which is formed in the top 13 and the shaft 63 has fixed on the lower end thereof a block 65 adapted to be engaged by an enlargement 66 which is carried by the toggle link 29. A spring 67 is interposed between the block 65 and the bottom of the top member 13 so as to constantly urge the crosshead 61 downwardly.

In the use and operation of this device, the press members 14 and 39 are connected with a source of steam pressure and heating supply so as to heat these press members to the desired degree. The cuff of a shirt is laid over the lower press member 39 with the extensions 53 and 54 extending partly within the sleeve. The operator 25 is actuated so as to rock press lever 43 downwardly at its upper and forward end to thereby lower the upper press member 14 onto the lower press member 39. At this time the two links 29 and 30 will be in substantial alignment with each other. At the time the upper press member 14 is in its lower pressing position encompassing the lower press member 39, the enlargement 66 on link 29 will strike block 65 thereby raising crosshead 61 and moving wedge members 58 upwardly to operative position for expanding the lower press members 43 and 44 at their

4

lower portions. The opposite ends of the cuff which are positioned adjacent the lower side portions of the lower members 43 and 44 will be thereby placed under additional pressure so as to smooth out any wrinkles which usually occur at the ends of the cuff and particularly around a cuff button. When the wedge members 58 move upwardly the press members 43 and 44 at their lower portions will move laterally with the bolts 46 sliding outwardly and the balls 48 providing anti-friction means to permit the free lateral sliding movement of the press members 43 and 44 under the pressure of the wedge members 58.

The structure may be formed as a complete cuff pressing machine or where a cuff pressing machine is available having an upper press member 14, the lower press members 39 with associated parts may be provided as an attachment for mounting on the frame of the ironing machine.

I do not mean to confine myself to the exact details of construction herein disclosed, but claim all variations falling within the purview of the appended claims.

What I claim is:

1. A cuff ironing machine comprising a frame, an upper movable press member formed with a concave lower side, means rockably mounting said press member on said frame, a lower press member formed with a convex upper side, a base for said lower member fixed to said frame, said lower member comprising a pair of hingedly connected together complementary members, means slidably mounting said pair of members on said base, means for moving said upper member toward said lower member, and means operable by said latter named means for expanding said pair of members when said upper member is in lower operative position.

2. A cuff ironing machine comprising a frame, an upper movable press member formed with a concave lower side, means rockably mounting said press member on said frame, a lower press member formed with a convex upper side, a base for said lower member fixed to said frame, said lower member comprising a pair of hingedly connected together complementary members, means slidably mounting said pair of members on said base, means for moving said upper member toward said lower member, and means operable by said upper member moving means for expanding said pair of members when said upper member is in lower operative position.

3. An attachment for a cuff ironing machine having a frame and an upper movable press member, said attachment comprising a complementary pair of lower press members, a base for said members adapted to be secured to said frame, means hingedly securing the upper edges of said members together, means slidably securing the bottoms of said members on said base, and means operable by movement of said upper press member to pressing position for moving the lower portions of said pair of members outwardly to tight pressing engagement relative to said upper member.

4. A cuff ironing machine comprising a frame, an upper press member, means rockably supporting said member, means for moving said member from an upper inoperative position to a lower operative position, a lower press member formed of a pair of hingedly connected together members, means mounting said pair of members on said frame for movement one relative to the other, and means for moving said pair of

5

members outwardly to pressing position when said upper member is in substantially the lower position of the latter.

5. A cuff ironing machine comprising a frame, an upper press member, means rockably supporting said member, means for moving said member from an upper inoperative position to a lower operative position, a lower press member formed of a pair of hingedly connected together members, means mounting said pair of members on said frame for movement one relative to the other, and means for moving said pair of members outwardly to pressing position when said upper member is in substantially the lower position of the latter, said latter named means including a part disposed in the path of movement of said second named means for operation thereby.

6. A cuff ironing machine comprising a frame, a pair of upper press members, means rockably supporting said members, means engaging said supporting means for moving said members

6

from an upper inoperative position to a lower operative position, a pair of lower press members each formed of a pair of hingedly connected together complementary members, means mounting said latter named members on said frame for movement one relative to the other, means for moving said complementary members relative to each other, said latter named means including a part disposed in the path of said second named means for operation thereby.

WILLIAM STEPHENSON COSTELLO.

REFERENCES CITED

The following references are of record in the file of this patent:

UNITED STATES PATENTS

Number	Name	Date
1,006,524	Bartholomew	Oct. 24, 1911
2,264,884	Mall	Dec. 2, 1941
2,463,777	Kagan	Mar. 8, 1949