

No. 667,529.

Patented Feb. 5, 1901.

W. JACOBS.  
WEFT REPLENISHING LOOM.

(Application filed May 19, 1900.)

(No Model.)

2 Sheets—Sheet 1.

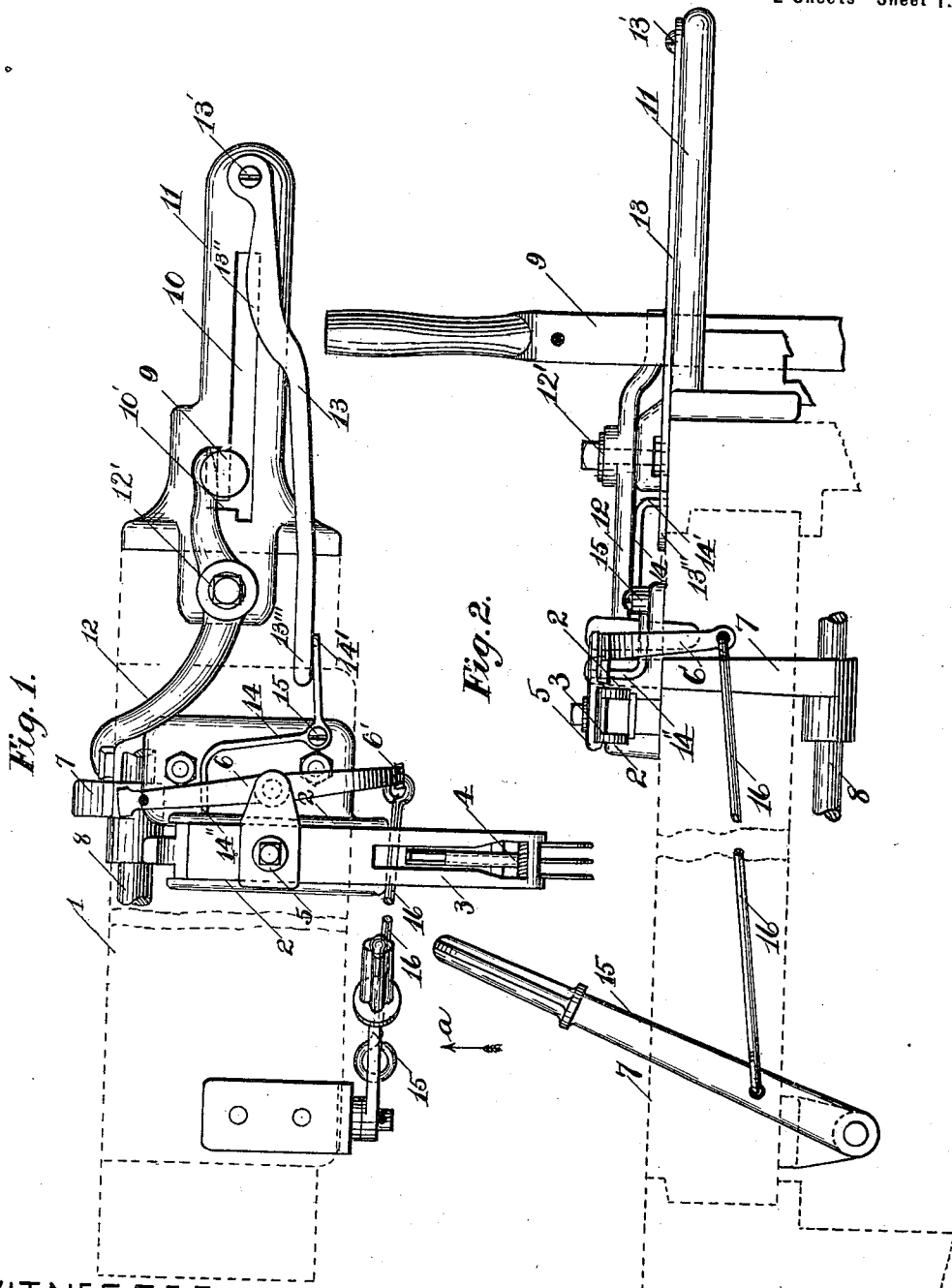

WITNESSES.

*Edmond F. Tourletotte*  
*W. Hoak.*

INVENTOR.

*William Jacobs*  
*by John C. Dewey*  
*Attorney*

W. JACOBS.  
WEFT REPLENISHING LOOM

(Application filed May 19, 1900.)

(No Model.)

2 Sheets—Sheet 2.

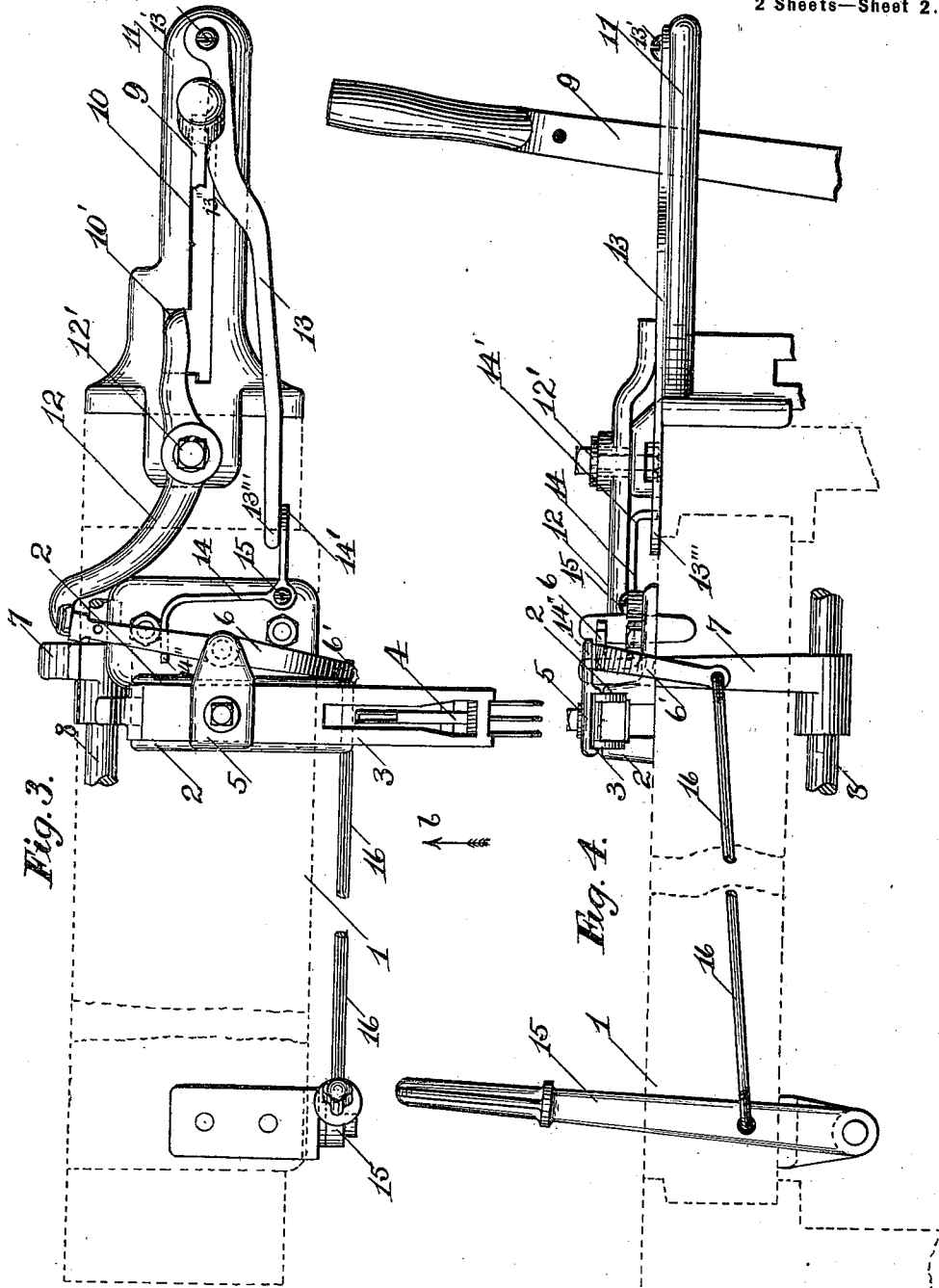

WITNESSES.

*Edmond F. Tourtellotte,*  
*W. Hall.*

INVENTOR.

*William Jacobs,*  
*by John C. Dewey*  
*Attorney.*

# UNITED STATES PATENT OFFICE.

WILLIAM JACOBS, OF PROVIDENCE, RHODE ISLAND, ASSIGNOR TO THE CROMPTON & KNOWLES LOOM WORKS, OF WORCESTER, MASSACHUSETTS.

## WEFT-REPLENISHING LOOM.

SPECIFICATION forming part of Letters Patent No. 667,529, dated February 5, 1901.

Application filed May 19, 1900. Serial No. 17,302. (No model.)

*To all whom it may concern:*

Be it known that I, WILLIAM JACOBS, a citizen of the United States, residing at Providence, in the county of Providence and State of Rhode Island, have invented certain new and useful Improvements in Weft-Replenishing Looms, of which the following is a specification.

My invention relates to that class of looms ordinarily termed "continuously-running" looms which have automatic filling or shuttle changing mechanism the operation of which is controlled by the movement of the filling-fork slide on the absence of filling. In this class of looms as ordinarily constructed and operated the movement of the shipper-lever to stop the loom and the stopping of the loom do not throw out of operation the filling-changing mechanism, so that upon the movement of the shipper-lever to start the loom the filling-changing mechanism may commence to operate at once and before the operator is ready to have it, and in this class of looms there is no connection between the weft-fork or filling-fork slide and the knock-off lever to operate the shipping mechanism to stop the loom, for in case of lack of filling the loom is not stopped, as in the ordinary loom, but new filling is supplied, and the shipping mechanism is only operated to stop the loom when the attendant operates it for any purpose or in case of the shuttle failing to box.

The object of my invention is to provide supplemental mechanism, combined with the shipper-lever and the filling-fork-slide mechanism, by means of which the manual movement of the shipper-lever to stop the loom will automatically throw out of action the mechanism for operating the filling-changing mechanism, and the same will remain out of action upon the return movement of the shipper-lever and until the operator puts said mechanism into position to be operative.

My invention consists in combining with the filling-fork-slide mechanism and the shipper-lever or shipping mechanism intermediate mechanism or connections for the purpose above stated, as will be hereinafter described.

I have shown in the drawings only sufficient parts of a filling-fork-slide mechanism and an operating-lever carried thereon for operating through intermediate connections the filling-changing mechanism, which may be of any well-known construction and operation, and a knock-off lever and shipper-lever, as will enable those skilled in the art to understand the construction and operation of my improvements combined therewith.

Referring to the drawings, Figure 1 is a plan view of a filling-fork slide carrying the pivoted lever for operating the filling-changing mechanism and the shipper-lever and the knock-off lever of ordinary construction and my supplemental mechanism or attachment combined therewith, showing the several parts in their normal position or the position they occupy when the loom is running. Fig. 2 is a side view of the parts shown in Fig. 1 looking in the direction of arrow *a*, same figure. Fig. 3 corresponds to Fig. 1, but shows the opposite position of some of the parts when the shipper-lever is knocked off; and Fig. 4 is a side view of the parts shown in Fig. 3 looking in the direction of arrow *b*, same figure.

In the accompanying drawings the breast-beam 1 of a loom is shown by broken lines. On top of the breast-beam at one end is mounted in ways 2 the filling-fork slide 3, carrying at its front end the pivoted filling-fork 4, to be engaged and tilted by the presence of filling to prevent the movement of the slide 3 in the ordinary way. On an arm or stand 5, secured to and moving with the slide 3, is centrally pivoted an actuating-lever 6, which has a pivotal motion in a horizontal plane and a reciprocating motion with the slide 3. On the absence of filling and the backward movement of the slide 3 the lever 6 is moved with it to engage an arm 7 fast on a rock-shaft 8 to rotate said shaft and through intervening mechanism operate the filling-changing mechanism to supply fresh filling in the ordinary way.

The shipper-lever 9 is connected at its lower end with the shipper mechanism in the ordinary way and extends at its upper end through the elongated slot 10 in the end casting 11

and when the loom is running extends in a side notch 10', leading out of the slot 10. The knock-off lever 12 is centrally pivoted at 12' and engages at one end the shipper-lever 9 to move said lever out of the notch 10' and into the slot 10 to operate the shipping mechanism and to stop the loom. The other end of the knock-off lever 12 is in position to be engaged by the actuating-lever 6 when said lever is moved into the position shown in Fig. 3.

I will now describe my supplemental attachment or mechanism, combined with the parts above described, to automatically move the actuating-lever 6 upon the movement of the shipper-lever to stop the loom into a position where it cannot operate the filling-changing mechanism.

In the present instance I have shown in the drawings by full lines one form of intermediate connections between the actuating-lever 6 and the shipper-lever 9, which consists of a lever or arm 13, pivoted at its outer end at 13' on the end of the casting 11 and provided with a cam-surface 13'', which extends in the path of and will be engaged by the shipper-lever 9 when the same moves outwardly. The other end 13''' of the lever 13 engages the downwardly-curved end 14' of an angle-lever 14, pivoted at 15. The other arm 14'' of the angle-lever 14 is bent upwardly to extend back of and engage the operating-lever 6, as shown. When the shipper-lever 9 moves out of the notch 10' and into the slot 10 to operate the shipping mechanism, it engages the cam-surface 13'' of the lever 13 and moves outwardly the free end of said lever, which in turn moves the angle-lever 14 and causes the operating-lever 6 to move from the position shown in Fig. 1 to the position shown in Fig. 3—that is, out of engagement with the arm 7 on the shaft 8, which operates through intermediate connections the filling-changing mechanism. When the shipper-lever 9 is returned to its position in the notch 10' to start the loom, the operating-lever 6 will still remain in the position shown in Fig. 3—that is, out of engagement with arm 7—so the filling-changing mechanism cannot be operated. The attendant may now move the lever 6 by hand into the position shown in Fig. 1 in readiness to operate the filling-changing mechanism. To move the lever 6 to position shown in Fig. 1, I prefer to employ a lever 15, pivoted on the breast-beam at the opposite end of the loom

and connected by a rod 16 with the downwardly-curved end 6' of the lever 6.

Instead of using the intermediate connections between the shipper-lever 9 and the actuating-lever 6, shown and described, I may use any other intermediate connections, if preferred.

The advantages of my improvements will be readily appreciated by those skilled in the art. The manual movement of the shipper-lever 9 to stop the loom will automatically move the actuating-lever 6 of the filling-changing mechanism to put it in a position where it cannot operate the filling-changing mechanism until the attendant is ready for it to operate, when he will return the lever 6 to its normal position.

It will be understood that the details of construction of my improvements may be varied, if desired, and the same may be adapted to be combined with different kinds of filling-changing mechanisms used on automatic looms and the shipper-lever or shipping mechanism.

Having thus described my invention, what I claim as new, and desire to secure by Letters Patent, is—

1. In a loom of the class referred to, the combination with the filling-fork slide, a lever carried thereon for putting into operation the filling-changing mechanism, and the shipper-lever, of intermediate mechanism, or connections, to automatically move the lever on the filling-fork slide into an inoperative position, when the shipper-lever is moved to stop the loom, substantially as shown and described.

2. In a loom of the class referred to, the combination with the filling-fork slide, a lever carried thereon for putting into operation the filling-changing mechanism, and the shipper-lever, of intermediate mechanism, or connections, to automatically move the lever on the filling-fork slide into an inoperative position, when the shipper-lever is moved to stop the loom, and means for moving said lever into an operative position when the shipper-lever is moved to start the loom, substantially as shown and described.

WILLIAM JACOBS.

Witnesses:

JOHN LEES,

PETER F. REILLY.