

(19) World Intellectual Property Organization
International Bureau



(43) International Publication Date
29 November 2001 (29.11.2001)

PCT

(10) International Publication Number
WO 01/90816 A1

- (51) International Patent Classification⁷: G03F 7/00, B41M 1/06, B81C 1/00
- (74) Agents: HYNELL, Magnus et al.; Hynell Patenttjänst AB, Patron Carls väg 2, S-683 40 Hagfors/Uddeholm (SE).
- (21) International Application Number: PCT/SE01/00787
- (81) Designated States (national): AE, AG, AL, AM, AT, AT (utility model), AU, AZ, BA, BB, BG, BR, BY, BZ, CA, CH, CN, CO, CR, CU, CZ, CZ (utility model), DE, DE (utility model), DK, DK (utility model), DM, DZ, EE, EE (utility model), ES, FI, FI (utility model), GB, GD, GE, GH, GM, HR, HU, ID, IL, IN, IS, JP, KE, KG, KP, KR, KZ, LC, LK, LR, LS, LT, LU, LV, MA, MD, MG, MK, MN, MW, MX, MZ, NO, NZ, PL, PT, RO, RU, SD, SE, SG, SI, SK, SK (utility model), SL, TJ, TM, TR, TT, TZ, UA, UG, US, UZ, VN, YU, ZA, ZW.
- (22) International Filing Date: 10 April 2001 (10.04.2001)
- (25) Filing Language: Swedish
- (26) Publication Language: English
- (30) Priority Data: 0001931-5 24 May 2000 (24.05.2000) SE
- (71) Applicant (for all designated States except US): OBDCAT AKTIEBOLAG [SE/SE]; P.O. Box 580, S-201 25 Malmö (SE).
- (84) Designated States (regional): ARIPO patent (GH, GM, KE, LS, MW, MZ, SD, SL, SZ, TZ, UG, ZW), Eurasian patent (AM, AZ, BY, KG, KZ, MD, RU, TJ, TM), European patent (AT, BE, CH, CY, DE, DK, ES, FI, FR, GB, GR, IE, IT, LU, MC, NL, PT, SE, TR), OAPI patent (BF, BJ, CF, CG, CI, CM, GA, GN, GW, ML, MR, NE, SN, TD, TG).
- (72) Inventor; and
- (75) Inventor/Applicant (for US only): HEIDARI, Babak [SE/SE]; Södra Ljungvägen 10, S-244 65 Furulund (SE).

[Continued on next page]

(54) Title: METHOD IN CONNECTION WITH THE PRODUCTION OF A TEMPLATE AND THE TEMPLATE THUS PRODUCED

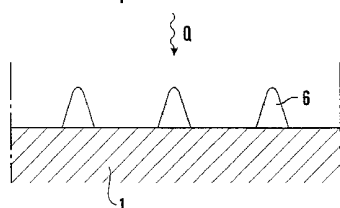
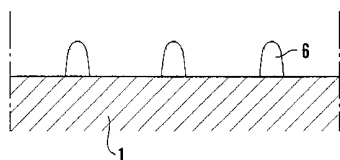
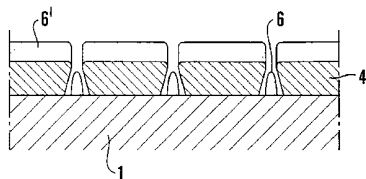
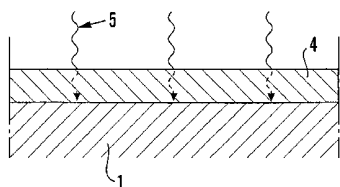

(57) Abstract: Method in connection with the production of a template, preferably for nanoimprint lithography, which template comprises a flat plate (1) of a first material and a three-dimensional structure (6, 8) of a second material, arranged on the plate, said second material introductory being applied on said plate, in the method, to form said structure. According to the invention, said second material is thereafter fixed to the plate of said first material, by heat treatment (Q) at at least 150°C, for the production of said template. The invention also relates to a template which has been produced by use of the method.



WO 01/90816 A1



Published:

— with international search report

For two-letter codes and other abbreviations, refer to the "Guidance Notes on Codes and Abbreviations" appearing at the beginning of each regular issue of the PCT Gazette.

METHOD IN CONNECTION WITH THE PRODUCTION OF A TEMPLATE AND THE TEMPLATE THUS PRODUCED

TECHNICAL FIELD

5 The present invention relates to a method in connection with the production of a template, which template comprises a flat plate of a first material and a three-dimensional structure of a second material, arranged on the plate, said second material introductory being applied on said plate, in the method, to form said structure. The method has primarily been developed for use in connection with the production of
10 semiconductor components by use of nanoimprint lithography, the template produced according to the method being used as a template in connection with series production of such semiconductor components, but it may also be used in connection with nanoimprint lithography on other rigid materials, such as ceramic materials, metals or polymers with a relatively high glass transition temperature, for us in e.g. biosensors.

15

PRIOR ART

The trend in microelectronics is towards ever smaller dimensions. In principle, development has been such that the dimensions are halving every third year. Commercial components are being manufactured today with structures of roughly 200
20 nm in size, but there is a need to go even further down in dimensions, to < 100 nm. Research concerning components based on quantum effects is now highly topical and a demand is being created for a commercially applicable manufacturing technique for components with dimensions < 10 nm. These nanocomponents can be produced currently using serial technology in individual specimens, for research purposes, but for
25 mass production a parallel production method is required. One such parallel production method that has been developed in recent times is nanoimprint lithography (NIL), US 5, 772, 905, which has set out the basic preconditions for the mass production of structures close to atomic scale, see *Stephen Y. Chou, Peter R. Krauss, Wei Zhang, Lingjie Guo and Lei Zhuang: "Sub-10nm imprint lithography and application", J. Vac. Sci. Technol. B, Vol. 15, No 6 (1997).*

30

The basic principle of NIL is mechanical deformation of a thin film layer, which is coated onto a flat plate of silicon. The NIL process can be compared with the production process for CDs and can be described in three stages:

35 1. Production of template: A template can be produced from various materials, e.g. metal, semiconductor, ceramic or from certain plastics. To create a three-dimensional structure on one surface of the template, various lithographic methods

can be used, depending on the requirements for the size of the structures and their resolution. E-beam and X-ray lithography are normally used for structure dimensions that are less than 300 nm. Direct laser exposure and UV lithography are used for larger structures.

- 5 2. Imprint: A thin layer of a polymer, e.g. polyamide, is applied to a flat substrate of silicon. The layer is heated and at a certain temperature, the so-called imprint temperature, the predefined template and substrate are pressed together, the inverse of the template's structure being transferred in the polymer layer to the substrate. After a lowering of the temperature, the template is separated from the substrate.
- 10 3. Structure transfer: In the areas pressed together in the polymer layer, a thin layer of polymer remains. The last stage is removal of this thin remaining layer on the substrate. This is carried out in a so-called "RIE" or O₂ plasma unit. The thinner this remaining layer is, the finer the structures that can be created using the nanoimprint process.

15

A known method which is used in step 1, i.e. the production of the template, is so called plating, more specifically electroplating. In that method, a flat plate of a semiconductor material or glass is coated by a layer of a polymeric material, a so called resist, preferably a positive resist. A positive resist is defined in this connection in that parts of
20 the polymeric resist material, which have been exposed to radiation, may be removed by a developing process, usually a developing bath. By radiation, e.g. by electron beam, UV radiation, exposure to laser or X-ray, there is defined a pattern in nanometer size in the resist, whereafter the resist is developed in the radiated parts thereof, according to the pattern, so that the plate is exposed in these parts. A thin layer of a metal, e.g. Cr,
25 Au, Ag or Al, is thereafter applied on the exposed parts of the plate and also on the remaining parts of the resist. The metal is thereby applied in a layer which is adequately even and covering in order to thereafter be able to be evenly contacted for an even voltage distribution, in a subsequent electroplating process. In such an electroplating process, the metal layer constitutes an electrode on which a thicker layer (typically of
30 about 300 µm) of e.g. Ni is built up during the electroplating. The Ni layer which has been built up is thereafter separated from the plate with the resist and the thin metal layer, simply by pulling them apart from each other, whereafter the Ni layer is ready to constitute the desired template. In this method, the structures in the template may be brought to exhibit a height of usually about 110-130 nm, but possibly up to 300 nm. The
35 problem of the method is however that it comprises many steps, having many parameters that have to be tuned in. Furthermore, it is often hard to achieve an adequately even voltage distribution in the plating and moreover, it is not possible to

produce very small structures, which is ever more required following the development in the field.

Another method which is used in the production of a template is so called etching. In this case, a flat plate of a semiconductor material, silicon/silicon dioxide, is coated by a polymeric material, a so called resist, preferably a positive resist. A pattern in nanometer size is defined in the resist by radiation, whereafter the resist is developed in the radiated parts thereof, according to the pattern, so that the plate is exposed in these parts. A metal, e.g. Cr, is thereafter applied on the exposed parts of the plate, whereafter the remaining parts of the resist are removed in a lift-off process. The desired three-dimensional structure may now be developed by etching, by plasma etching, whereby the metal according to the pattern constitutes a mask. Accordingly, the etching is performed in the semiconductor material and the structure is formed in this semiconductor material with the metal as a top layer on the separate elements of the structure. A problem which quite often arises thereby is that the etching also acts in a lateral direction to a certain degree, causing that the metal material forms a "hat" that somewhat protrudes outside every separate element of the structure. This "hat" risks to get caught in the polymeric material on the substrate in connection with imprint step no. 2 according to the above, which results in an unacceptable result of the imprint.

Up to now, it has not been possible to use a template where the three-dimensional structure only consists of a metal material which is applied according to the first steps in the etching method just described, i.e. the steps up to and including the lift-off process. This depends on the fact that the metal, which in that case would be applied in greater thickness, is too loosely adhered to the plate. Accordingly, parts of the structure come loose from the plate whereby the template soon becomes useless for its purpose.

BRIEF DESCRIPTION OF THE INVENTION

The present invention aims at solving the above complex of problems and at presenting a method in connection with the production of a template, preferably for nanoimprint lithography, which method is simple, cheap and repetitive and which yields durable structures of small size and with a beneficial profile for a subsequent imprint step.

These and other purposes are attained by the method according to the invention, as it is defined in the claims.

The template is produced according to the invention by the second, structure forming, material being applied onto the first material, the plate, according to a technique known per se, e.g. by the forming of a pattern in a resist material followed by evaporation of the second material onto the plate, whereby the resist material constitutes a mask. After
5 this, a heat treatment step is conducted according to the invention at at least 150 °C but below the melting temperature for the second material, whereby the structural details are fixed onto the plate, for the formation of a durable template.

Without restricting the invention to a certain theory, it is probable that the desired fixing
10 is achieved by chemical interaction between the surfaces of the first and second material, facing each other. For example, when the first material consists of SiO₂ and the second material consists of Cr, it is probable that chromium oxide is formed in the heat treatment, possibly only for a few atoms in the interface layer, which effects a binding between the two materials.

15

DETAILED DESCRIPTION OF THE INVENTION

In the following, the invention will be described in greater detail with reference to the drawings, of which:

- 20 Fig. 1 is showing, in cross-section, a number of different three-dimensional structures on a template, whereof some are beneficial and others are non-beneficial,
Fig. 2a-d is showing, in cross-section, the process steps for the production of a template according to a first embodiment of the invention,
25 Fig. 3a-c is showing, in cross-section, the process steps for the production of a template according to a second embodiment of the invention,
Fig. 4a-c is showing, in cross-section and a light perspective, SEM pictures of three different templates which have been produced according to the invention.

30

In Fig. 1 there is shown, in cross-section, a number of different structural details which may be produced on a template, according to known technique. On a plate 1, there has been produced different imagined structural details 3a-e, of a material 2. Detail no. 3a exhibits a non-beneficial profile, which after imprint in a resist that has been softened
35 by heating and solidified by cooling, on a not shown substrate, risks to get caught in the resist on the substrate. This is also the case for structural detail no. 3b, which has been produced by etching according to the description above of known techniques, and which

exhibits a protruding "hat". The structural details 3c, 3d and possibly even 3e are on the contrary beneficial for imprint. Such structural details may be produced by electroplating according to the description above of known techniques, but not in sizes that are small enough and not with sufficient simplicity. According to the invention, there may beneficially be produced structural details according to the preferred examples 3c and 3d, on a template, in desired small dimensions, in a way that is simple, cheap, durable and repetitive.

In Fig. 2a there is shown, in cross-section, a plate 1 of a first material, e.g. a metal material, a semiconductor material or a polymeric material. The plate 1 has been coated on one side thereof, in a previous step, by a layer 4 of a resist material, suitably a positive resist. The resist material 4 is exposed to radiation 5 which defines a pattern for the desired structure, the radiation 5 preferably consisting of an electron beam. It is however also conceivable to use radiation in the form of e.g. X-ray radiation, laser radiation or UV radiation. The pattern may e.g. consist of lines or dots in the resist material 4. In Fig. 2b, the template is shown after the resist material 4 having been developed in a manner known per se, so that the plate 1 is exposed according to the pattern in the radiated parts of the pattern, and after the second material 6 according to the invention having been applied, preferably by evaporation, on the thus exposed parts of the plate 1. The second material 6 consists of a metal material, preferably chosen from the group that consists of Al, Ni, Cr, W, Ti, Au or alloys of the same, e.g. Ti-Au, and is applied with a thickness of about 150Å – 300 nm, for the formation of a three-dimensional structure. Of course, metal 6' will settle on the resist material 4 too, in connection with the evaporation, which however is of no relevance to the invention. In connection with this, it is an advantage of the invention that the thickness of the three-dimensional structure is very easy to control at the evaporation.

In Fig. 2c, the rest of the resist material 4 has been removed, as has metal material 6' lying on the same. This has preferably been done by use of a lift-off process, e.g. dissolving in acetone, which process is known per se. The metal material 6 remains on the plate 1 and forms the desired three-dimensional structure, which however is too loosely adhered to the plate 1 at this moment, for the plate 1 with the material 6 to be used as a template.

In Fig. 2d, there is shown how the metal material 6 has changed somewhat in profile after a heat treatment step according to the invention, which has been symbolically denoted by a "Q". The profile has thereby, to a slight extent, become more beneficially

sloping and moreover, which is most important, the metal material 6 has been fixed to the plate 1, probably by chemical interaction in the interface between the metal material 6 and the plate 1. The heat treatment Q is according to the invention performed at a temperature which is lower than a melting temperature for the metal material 6 and which of course is also lower than a melting temperature for the material of the plate 1. Suitably, the temperature during the heat treatment is at least 200°C, preferably at least 250°C and even more preferred at least 350°C, but 800°C at the most, preferably 750°C at the most and even more preferred 650°C at the most. Furthermore, the heat treatment is performed during a time period of at least 1 minute, preferably at least 2 minutes and even more preferred at least 5 minutes, but 2 hours at the most, preferably 1.5 hours at the most and even more preferred 1 hour at the most. The heat treatment may take place in an atmosphere containing oxygen, but also in an atmosphere of nitrogen gas, and may be performed in an oven, on a heating plate or in another way.

In Fig. 3a-c there is shown the process steps for production of a template according to a second embodiment of the invention. The plate 1, which may be of the same material as the plate in Fig. 2a-d, has in Fig. 3a been coated by a 150Å – 300 nm thick layer of a polymeric material 7, preferably a resist and even more preferred a negative resist, e.g. a negative resist which is sold by Micro Resist Technology GmbH under the name SU8. A negative resist is defined in this connection by the polymeric resist material being cross-linked at exposure to heat or radiation, whereafter non-exposed parts may be removed by aid of a developing process, usually a developing bath of different type depending on the type of resist. The resist 7 is exposed to radiation 5, which defines a pattern for the desired structure, the radiation 5 suitably consisting of an electron beam. It is however also conceivable to use radiation in the form of e.g. X-ray radiation, laser radiation or UV radiation. The pattern may e.g. consist of lines or dots in the resist material 7.

Fig. 3b is showing the template after the resist material 7 having been developed in a manner known per se, so that the non-exposed parts of the resist 7 has been removed. The remaining parts 8 are cured by heat treatment at a temperature that is lower than the temperature for the heat treatment according to the invention, whereafter the structural details 8 are subjected to the heat treatment according to the invention, symbolically denoted "Q". Also in this case, the heat treatment results in a somewhat more sloping profile (Fig. 3c), and in that the structural details 8 are bonded to the plate 1. The heat treatment Q is performed in the same way as has been described with reference to Fig.

2d, but preferably at a temperature which is in a lower part of the defined range, e.g. at about 260-300°C.

In Fig. 4a-c there is shown three different templates which have been produced
5 according to the first embodiment of the invention, and which accordingly have been
heat treated for 10 minutes at 200°C, 400°C and 600°C, respectively. The three-
dimensional structure consists of lines of aluminium applied on a plate of silicon.
Already at a heat treatment at 200°C (Fig. 4a), the metal adheres well to the plate and
the profile is good enough for imprint purpose. At a heat treatment at 400°C (Fig. 4b),
10 the profile of the structural elements has become somewhat more beneficially sloping,
and at 600°C (Fig. 4c) it is evident that the profile is considerably sloping.

Preferably, but definitively not necessarily, the template which is produced is used in a
device for lithography of structures of nanometer size, as is described in the co-pending
15 application SE-A0-9904517-1 of the same applicant.

The invention is not limited to the embodiments described above, but may be varied
within the scope of the claims. Accordingly, it is realised that the method for the
production of a template also may be used in connection with the production of other
20 objects than semiconductor components, biosensors etc., e.g. in connection with the
production of CD's (Compact Discs). It is also realised that the second, structure
forming, material may be applied onto the first material in other ways, possibly not yet
developed. In this connection it is also conceivable that the first and the second material
consist of the same material. Furthermore, it is realised that the resist layer which is
25 used in connection with the application of the second material according to the
invention, with reference to Fig. 2a, when this second material consists of a metal
material, may be formed from more than one layer, e.g. a lower layer of a positive resist
and an upper layer of a negative resist, with the purpose of achieving beneficially
undercut profiles in the resist material, as is described in the co-pending application SE-
30 A0-0001430-8 of the same applicant.

CLAIMS

1. Method in connection with the production of a template, preferably for nanoimprint lithography, which template comprises a flat plate (1) of a first material and a three-dimensional structure (6, 8) of a second material, arranged on the plate, said second material introductory being applied on said plate, in the method, to form said structure, characterised in that said second material thereafter is fixed to the plate of said first material, by heat treatment (Q) at at least 150°C, for the production of said template.
2. Method according to claim 1, characterised in that said first material is chosen from the group that consists of metal materials, semiconductor materials, ceramic materials or polymeric materials.
3. Method according to claim 1 or 2, characterised in that said second material consists of a metal material, preferably chosen from the group that consists of Al, Ni, Cr, W, Ti, Au and alloys of these materials.
4. Method according to claim 1 or 2, characterised in that said second material consists of a polymeric material, preferably a resist material.
5. Method according to any one of the preceding claims, characterised in that said heat treatment (Q) is performed at a temperature which is lower than a melting temperature of said second material, suitably a temperature of at least 200°C, preferably at least 250°C and even more preferred at least 350°C, but 800°C at the most, preferably 750°C at the most and even more preferred 650°C at the most.
6. Method according to any one of the preceding claims, characterised in that said heat treatment (Q) is performed during a time period of at least 1 minute, preferably at least 2 minutes and even more preferred at least 5 minutes, but 2 hours at the most, preferably 1.5 hours at the most and even more preferred 1 hour at the most.
7. Method according to any one of the preceding claims, characterised in that said heat treatment (Q) is performed in an atmosphere containing oxygen.

8. Method according to any one of claims 1-6, characterised in that said heat treatment (Q) is performed in an atmosphere of nitrogen gas.
9. Method according to claim 3, characterised in that said introductory application
5 of said second material comprises the steps that
(a) said plate (1) is coated with a layer (4) of a resist material on one of its sides,
(b) the resist material (4) in step (a) is exposed to a radiation (5) which defines a pattern for said structure, preferably by means of an electron beam,
(c) the resist material (4) in step (b) is developed so that the plate (1) is exposed
10 according to the pattern, preferably in the radiated parts of the pattern,
(d) said second material is applied, preferably by evaporation, on the exposed parts of the plate (1), and that
(e) the remaining part of the resist material is removed, preferably in a lift-off process, whereafter said second material remains on the plate (1) and forms said
15 structure (6).
10. Method according to claim 4, characterised in that said introductory application of said second material comprises the steps that
(a) said plate (1) is coated with a layer (7) of said second material on one of its
20 sides,
(b) the second material in step (a) is exposed to a radiation (5) which defines a pattern for said structure, preferably by means of an electron beam,
(c) the second material in step (b) is developed so that the plate (1) is exposed according to the pattern, preferably in the non-radiated parts of the pattern, and that
25 (e) the remaining part of the second material is cured at a temperature which is lower than the temperature for said heat treatment, whereby said second material forms said structure (8).
11. Method according to any one of the preceding claims, characterised in that said
30 second material is applied at a thickness of 150Å-300 nm for the formation of said structure (6, 8).
12. Template for nanoimprint lithography, which template comprises a flat plate (1) of a
35 first material and a three-dimensional structure (6, 8) of a second material, arranged on the plate, characterised in that said plate has been produced by use of the method according to any one of claims 1-11.

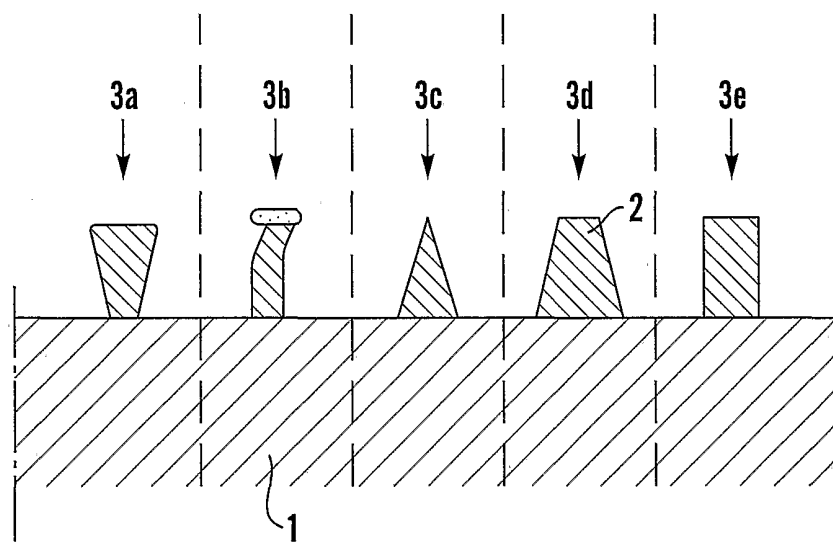

Fig. 1

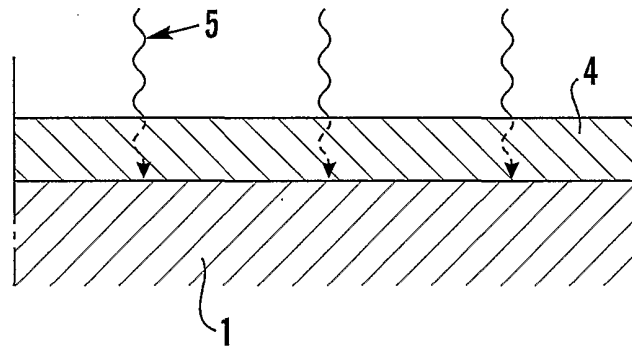

Fig. 2a

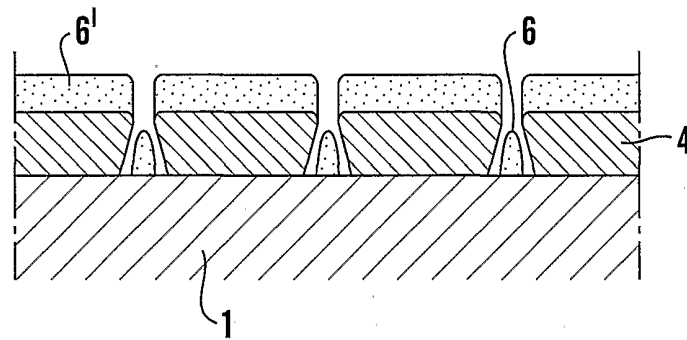

Fig. 2b

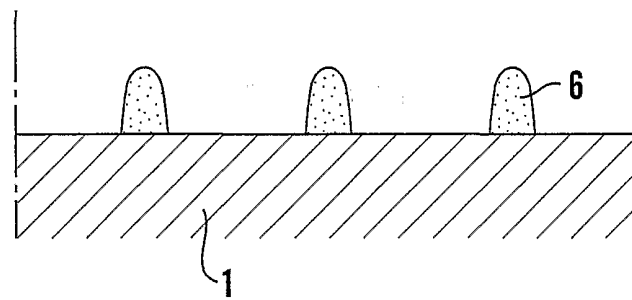

Fig. 2c

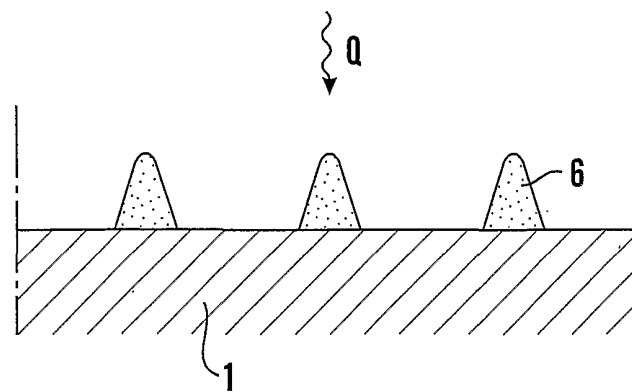

Fig. 2d

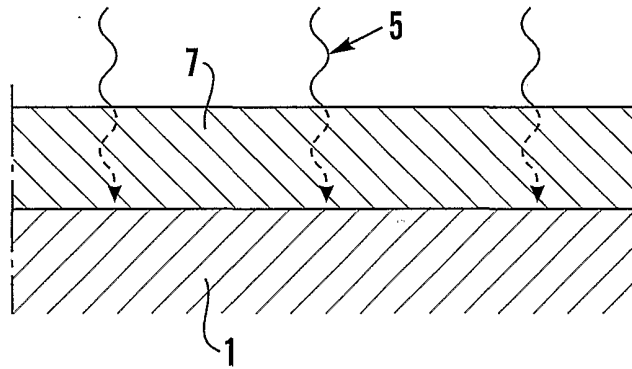

Fig.3a

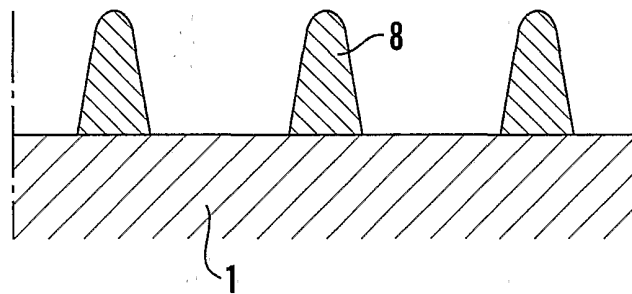

Fig.3b

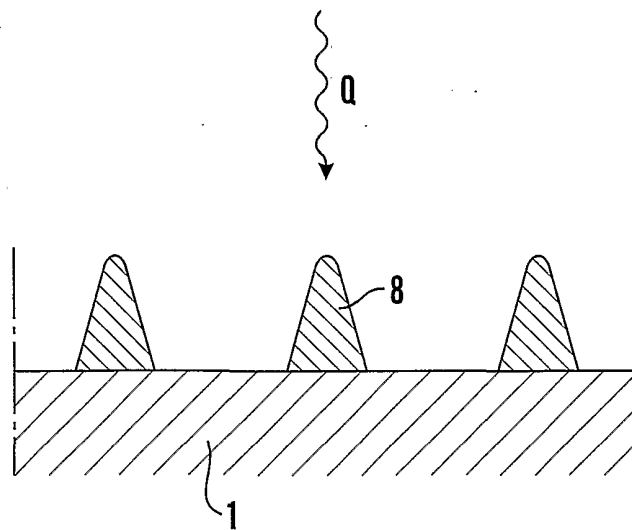

Fig.3c

Fig. 4a

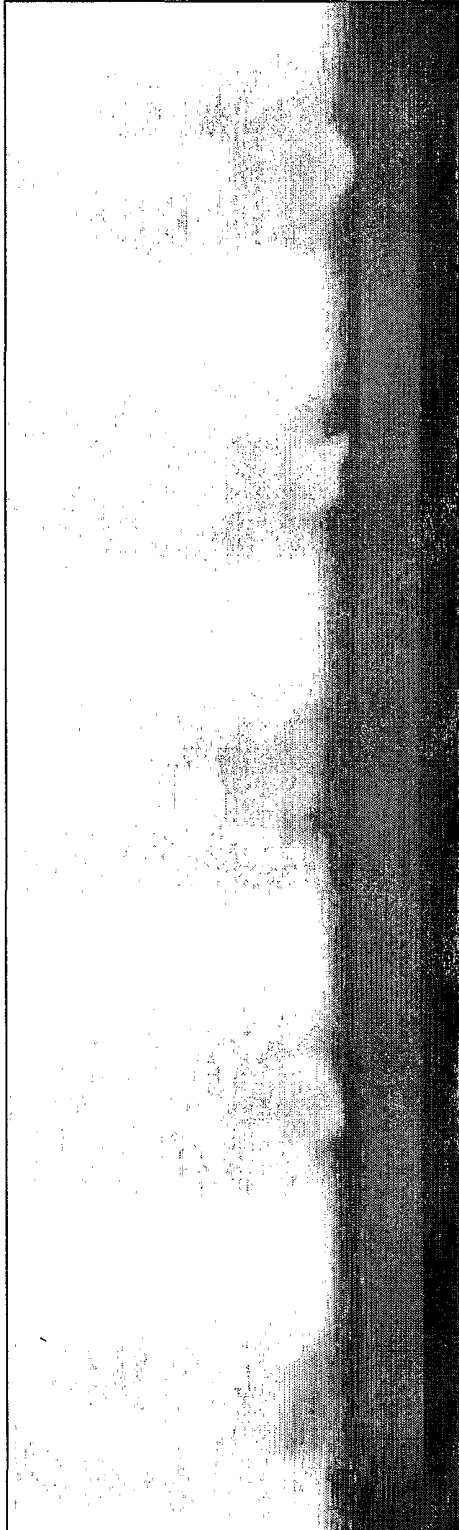

Fig. 4b

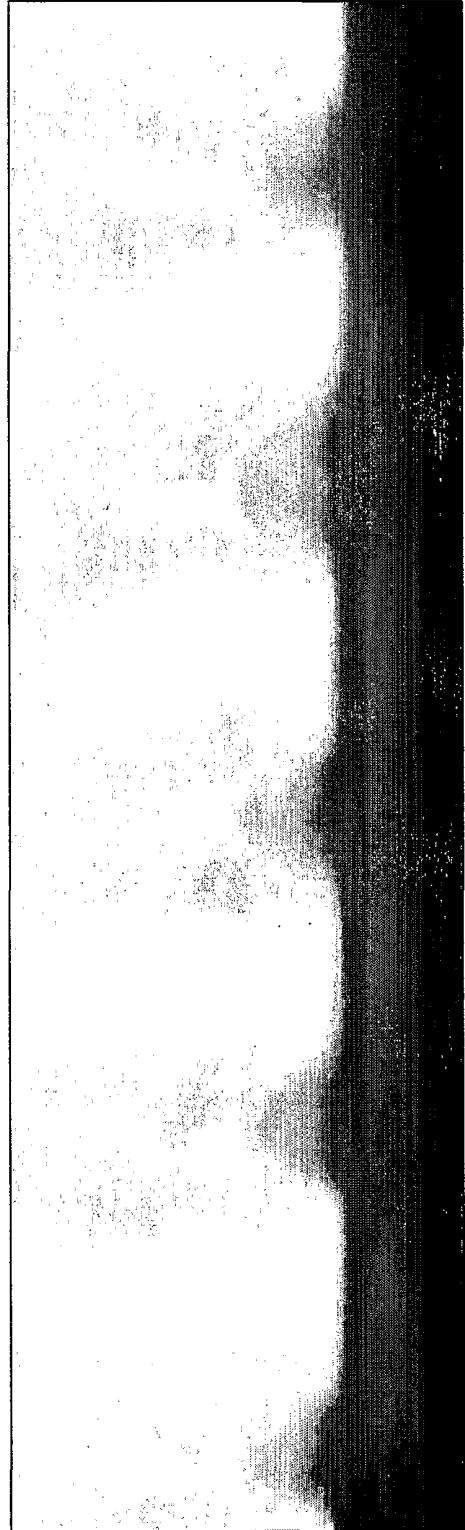
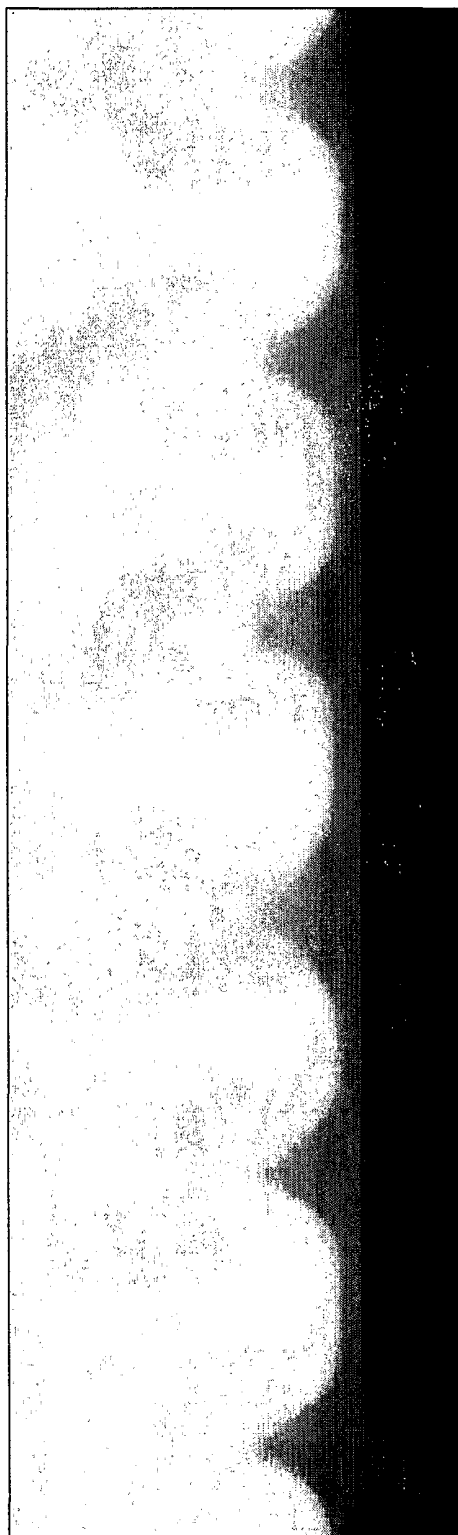

Fig. 4c



100nm

INTERNATIONAL SEARCH REPORT

International application No.
PCT/SE 01/00787

A. CLASSIFICATION OF SUBJECT MATTER

IPC7: G03F 7/00, B41M 1/06, B81C 1/00

According to International Patent Classification (IPC) or to both national classification and IPC

B. FIELDS SEARCHED

Minimum documentation searched (classification system followed by classification symbols)

IPC7: B41M, B81C, G03F

Documentation searched other than minimum documentation to the extent that such documents are included in the fields searched

SE,DK,FI,NO classes as above

Electronic data base consulted during the international search (name of data base and, where practicable, search terms used)

C. DOCUMENTS CONSIDERED TO BE RELEVANT

| Category* | Citation of document, with indication, where appropriate, of the relevant passages | Relevant to claim No. |
|-----------|--|-----------------------|
| A | DE 19755712 A1 (INDUSTRIAL TECHNOLOGY RESEARCH INSTITUTE), 1 July 1999 (01.07.99), figures 1a-1d, claim 1 -- | 1-12 |
| A | DE 19815130 A1 (ROBERT BOSCH GMBH), 14 October 1999 (14.10.99), column 2, line 48 - line 63, figures 1-4 -- | 1-12 |
| A | US 5162078 A (PETER BLEY ET AL), 10 November 1992 (10.11.92), column 2, line 57 - column 3, line 6, figure 1 -- | 1-12 |

 Further documents are listed in the continuation of Box C. See patent family annex.

* Special categories of cited documents:

"A" document defining the general state of the art which is not considered to be of particular relevance

"E" earlier application or patent but published on or after the international filing date

"L" document which may throw doubts on priority claim(s) or which is cited to establish the publication date of another citation or other special reason (as specified)

"O" document referring to an oral disclosure, use, exhibition or other means

"P" document published prior to the international filing date but later than the priority date claimed

"T" later document published after the international filing date or priority date and not in conflict with the application but cited to understand the principle or theory underlying the invention

"X" document of particular relevance: the claimed invention cannot be considered novel or cannot be considered to involve an inventive step when the document is taken alone

"Y" document of particular relevance: the claimed invention cannot be considered to involve an inventive step when the document is combined with one or more other such documents, such combination being obvious to a person skilled in the art

"&" document member of the same patent family

Date of the actual completion of the international search

14 June 2001

Date of mailing of the international search report

19-06-2001

Name and mailing address of the ISA/
Swedish Patent Office
Box 5055, S-102 42 STOCKHOLM
Facsimile No. +46 8 666 02 86

Authorized officer

Bengt Christensson/MP
Telephone No. +46 8 782 25 00

INTERNATIONAL SEARCH REPORT

International application No.

PCT/SE 01/00787

C (Continuation). DOCUMENTS CONSIDERED TO BE RELEVANT

| Category* | Citation of document, with indication, where appropriate, of the relevant passages | Relevant to claim No. |
|-----------|--|-----------------------|
| A | US 5944974 A (JENS FAHRENBERG ET AL), 31 August 1999 (31.08.99), column 2, line 36 - column 3, line 12; column 4, line 12 - line 16, claims 1-3 -- | 1-12 |
| A | US 5676983 A (WALTER BACHER ET AL), 14 October 1997 (14.10.97), column 4, line 46 - line 51, figures 2a-2b -- | 1-12 |
| A | US 5645977 A (TUNG-CHUAN WU ET AL), 8 July 1997 (08.07.97), column 3, line 46 - column 4, line 1, figures 6a-6e -- | 1-12 |
| A | US 5512131 A (AMIT KUMAR ET AL), 30 April 1996 (30.04.96), column 7, line 18 - line 41, figure 1a -- ----- | 1-12 |

INTERNATIONAL SEARCH REPORT

Information on patent family members

28/05/01

International application No.

PCT/SE 01/00787

| Patent document cited in search report | Publication date | Patent family member(s) | Publication date |
|--|------------------|--|--|
| DE 19755712 A1 | 01/07/99 | NONE | |
| DE 19815130 A1 | 14/10/99 | NONE | |
| US 5162078 A | 10/11/92 | DE 3937308 C EP 0500620 A,B JP 2511197 B JP 3504543 T WO 9107700 A | 21/03/91 02/09/92 26/06/96 03/10/91 30/05/91 |
| US 5944974 A | 31/08/99 | DE 19524099 A DE 59602337 D EP 0836540 A,B SE 0836540 T3 JP 3032018 B JP 10510483 T WO 9702108 A | 02/01/97 00/00/00 22/04/98 10/04/00 13/10/98 23/01/97 |
| US 5676983 A | 14/10/97 | AT 136950 T DE 4219667 A,C DE 59302281 D EP 0646188 A,B JP 2625580 B JP 7504624 T US 5795519 A WO 9325732 A | 15/05/96 23/12/93 00/00/00 05/04/95 02/07/97 25/05/95 18/08/98 23/12/93 |
| US 5645977 A | 08/07/97 | DE 19542658 A | 22/05/97 |
| US 5512131 A | 30/04/96 | US 5900160 A US 6180239 B | 04/05/99 30/01/01 |