

(No Model.)

3 Sheets—Sheet 3.

J. H. KONITZKY.
STEERING APPARATUS.

No. 385,936.

Patented July 10, 1888.

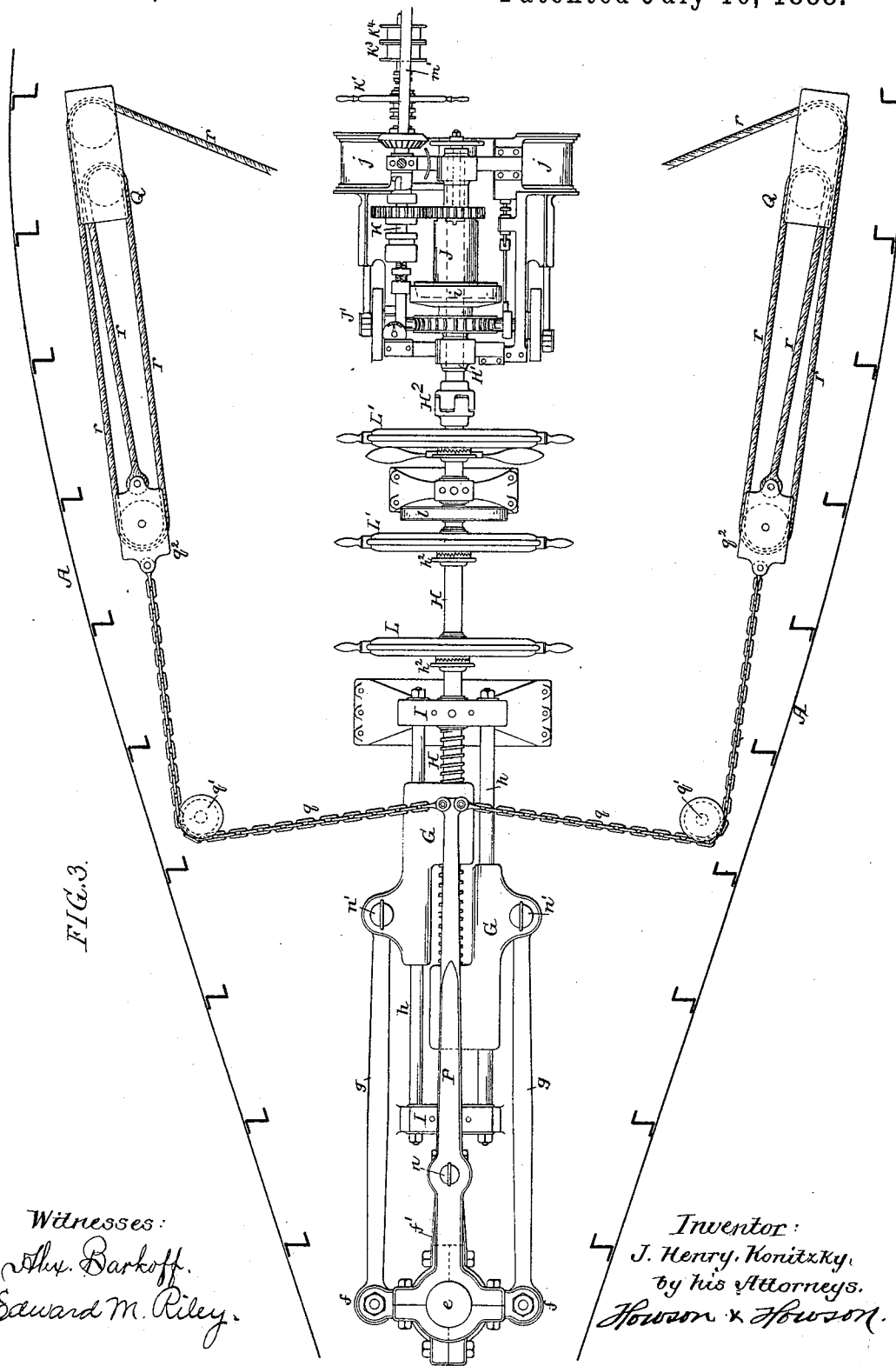

FIG. 3.

Witnesses:
Thos. Barkoff.
Edward M. Riley.

Inventor:
J. Henry Konitzky.
by his Attorneys,
Howson & Howson.

UNITED STATES PATENT OFFICE.

J. HENRY KONITZKY, OF PHILADELPHIA, PENNSYLVANIA.

STEERING APPARATUS.

SPECIFICATION forming part of Letters Patent No. 385,936, dated July 10, 1888.

Application filed May 5, 1888. Serial No. 272,911. (No model.)

To all whom it may concern:

Be it known that I, J. HENRY KONITZKY, a citizen of the United States, and a resident of Philadelphia, Pennsylvania, have invented certain Improvements in Steering-Gear for Vessels, of which the following is a specification.

My invention relates to improvements in steam steering-gear, especially adapted to vessels of war, the main object of my invention being to provide means whereby, in case of the derangement of one form of steering gear, another form can be at once availed of, and a further object being to provide for operating the rudder from a number of different points, so as to prevent disabling of the vessel in case of accident to one or more of the connections.

In the accompanying drawings, Figure 1 is a longitudinal section of sufficient of a vessel to illustrate my invention. Fig. 2 is an enlarged sectional view of part of Fig. 1 to show the steering-gear more clearly, and Fig. 3 is a sectional plan view of said steering-gear.

A is the hull of the vessel, and B are the different decks, C being the protective deck, in the present instance situated below the water-line of the vessel. Under this protective deck and mounted on the deck D below the same are the main operative parts of the steering mechanism.

The stock *e* of the rudder E projects up into the compartment beneath the protective deck C, as shown, and on this stock is a cross-head, F, having two arms, *f f'*, to which are connected, respectively, rods *g g*, the front ends of which are connected to nuts G G, which are adapted to a stem or shaft, H, having a right and left handed screw thereon—one for one nut and the other for the other nut—said stem or shaft H having its bearings in suitable boxes, I I. On each side of this screw-shaft are guide-rods *h h* for the nuts G G, these rods extending from one box I to the other, and thus tending to stiffen the structure.

By turning the screw in one direction the nuts G G will be moved toward each other, so as to swing the rudder to starboard; but if the motion of the shaft is reversed the nuts will be moved away from each other and the rudder will be swung to port, the rudder, when the nuts are in the position shown in Fig. 3,

being held amidships. This apparatus is what is termed "screw steering-gear."

Forward of the shaft of the screw-gear is placed a steam steering device, preferably of that character in which opposite steam-cylinders *j* operate a crank-shaft geared by worm-gearing to a shaft, H', carrying the winding-drum J, the shaft H' in the present instance being in line with the projecting shaft H of the screw steering-gear and capable of being clutched to or released therefrom by means of the loose coupling H².

Mounted on the rudder-stock *e*, above the cross-head F, is a tiller, P, to the inner end of which are secured chains *q*, which pass around guide-pulleys *q'* on the starboard and port sides of the vessel, and are connected to blocks *q''*. From each of these blocks extends an operating cord or chain, *r*, which passes from the block first around one sheave of a stationary frame, Q, then back around the sheave of the block, then forward around a second sheave of the stationary frame, and then to the drum, the ends of the rope or chain being wound upon the drum J in opposite directions, so that on turning the drum so as to wind up one of the ropes the other rope will be unwound therefrom.

Projecting forward from the rudder-stock *e* is an arm, *f'*, and this arm may be secured to the tiller P by means of a detachable pin or bolt, *n*, the forward ends of the connecting-rods *g* of the screw steering-gear being likewise secured to the nuts G by means of detachable bolts or pins *n'*, so that the rudder may be connected to or disconnected from either the tiller or the nuts of the screw steering-gear, the tiller being disconnected when the nuts are fast, and the nuts being disconnected when the tiller is bolted to the arm of the rudder-stock, and the tiller, when not in use, being held in the midship position by means of a retaining-chain, *p*, as shown in Fig. 2.

It will thus be seen that the steering-engine can be used for operating the screw steering-gear; or, if the latter is disabled or its use is not desired, the steering-engine may operate the rudder by means of the tiller-connections. The screw steering-gear may also be operated by hand, if desired, the shaft H being provided with a steering-wheel, L, which can be

connected to or released from the shaft by means of a clutch, h^2 , and on the shaft are additional steering-wheels, L' , also provided with clutches, so that additional power may be applied to the shaft; or, if the screw steering-gear is disconnected, these steering-wheels may be used for operating the drum-shaft H' of the steam steering-gear if the steam driving mechanism of the same is not available. The shaft H has a brake-drum, l , the strap l' of which is connected to a treadle-lever, l^2 , as shown in Fig. 2.

The valve of the steam steering-gear is controlled from a counter-shaft, K , at one side of the drum-shaft, and this shaft can be operated in various ways and from various parts of the ship. For instance, it may be operated directly by means of a hand-wheel, K' ; or it may be operated by wheels M , located in the stern of the vessel, just beneath the poop-deck, and acting through the medium of shafts m , m' , and m^2 and suitable interposed bevel-gears; or the shaft K may be operated from a wheel-house, S , or conning-tower S' on the main deck forward, the shaft K having two arms, K^3 K^4 , upon which are wound in opposite directions the ends of a rope or chain, K^2 , which passes around guide-pulleys K^5 , and is connected to a drum, K^6 , on the shaft K^7 , this shaft being operated by bevel-gearing, either from the shaft of the steering-wheel N in the conning-tower or from that of the steering-wheel N' in the wheel-house; or shafting may be used exclusively from the wheel to the steering-engines.

It will thus be seen that when the steam steering-gear is operative it can be operated either from steering-wheels in the wheel-house, conning-tower, or under the poop-deck, and if all these connections are destroyed it can still be operated directly by hand from beneath the protective deck, and if the steam-operating mechanism is deranged or destroyed the drum and tiller steering device may still be operated directly by hand; or, in the event of accident to the tiller, the screw steering device can be used, and this device can be operated either by the steam steering mechanism or by hand, ample provision being thus made for preventing the disabling of the vessel by reason of the derangement or destruction of one or more of the steering-connections.

The locating of the steam steering device in advance of the screw steering device and with its drum-shaft in line with the shaft of said screw steering device insures compactness in

the arrangement of the parts—a feature of considerable importance, owing to the fact that all the steering-gear must be located in a limited space below the protective deck and must be contained in a space of limited lateral dimensions, owing to the narrowness of the hull at and near the stern-post.

I claim as my invention—

1. In steering apparatus, the combination of the rudder having a cross-head, and a screw-shaft having traveling nuts connected to the opposite ends of said cross-head, with a steering-engine the shaft of which is in line with and forms a continuation of said screw-shaft, substantially as described.

2. The combination of the rudder having a cross-head and arm, a screw-shaft having traveling nuts detachably connected to said cross-head, and a tiller detachably connected to the arm of the rudder, all substantially as specified.

3. In steering apparatus, the combination of the rudder and its cross-head, the screw-shaft, the traveling nuts thereon, detachably connected to the cross-head, a steering-engine for driving the screw, a tiller detachably secured to the rudder, and connections between the drum of the steering-engine and the tiller, substantially as described.

4. In steering apparatus, the combination of the rudder having a cross-head, a screw, and traveling nuts thereon, connected to said cross-head, with a steering-engine the shaft of which is detachably connected to the screw-shaft, and valve apparatus and their operating devices controlling the steering-engine and located at convenient points on the ship remote from the engine, all substantially as specified.

5. The combination of the rudder, its cross-head and tiller, the screw-shaft and its nuts detachably connected to the cross-head, a steam steering apparatus constructed to operate either the screw-shaft or the tiller, and steering-wheels for operating directly by hand either the screw-shaft or the tiller-drum of the steam steering apparatus, all substantially as specified.

In testimony whereof I have signed my name to this specification in the presence of two subscribing witnesses.

J. HENRY KONITZKY.

Witnesses:

H. F. REARDON,
HENRY HOWSON.