



(11) (21) (C) **2,164,589**
(86) 1994/06/08
(87) 1994/12/22
(45) 2000/10/10

(72) Meguro, Yasuo, JP

(73) Hisamitsu Pharmaceutical Co., Inc., JP

(51) Int.Cl.⁶ A61N 1/30

(30) 1993/06/08 (5/163299) JP

(54) **SYTEME THERAPEUTIQUE PAR IONOPHORESE**

(54) **IONTOPHORESIS SYSTEM**

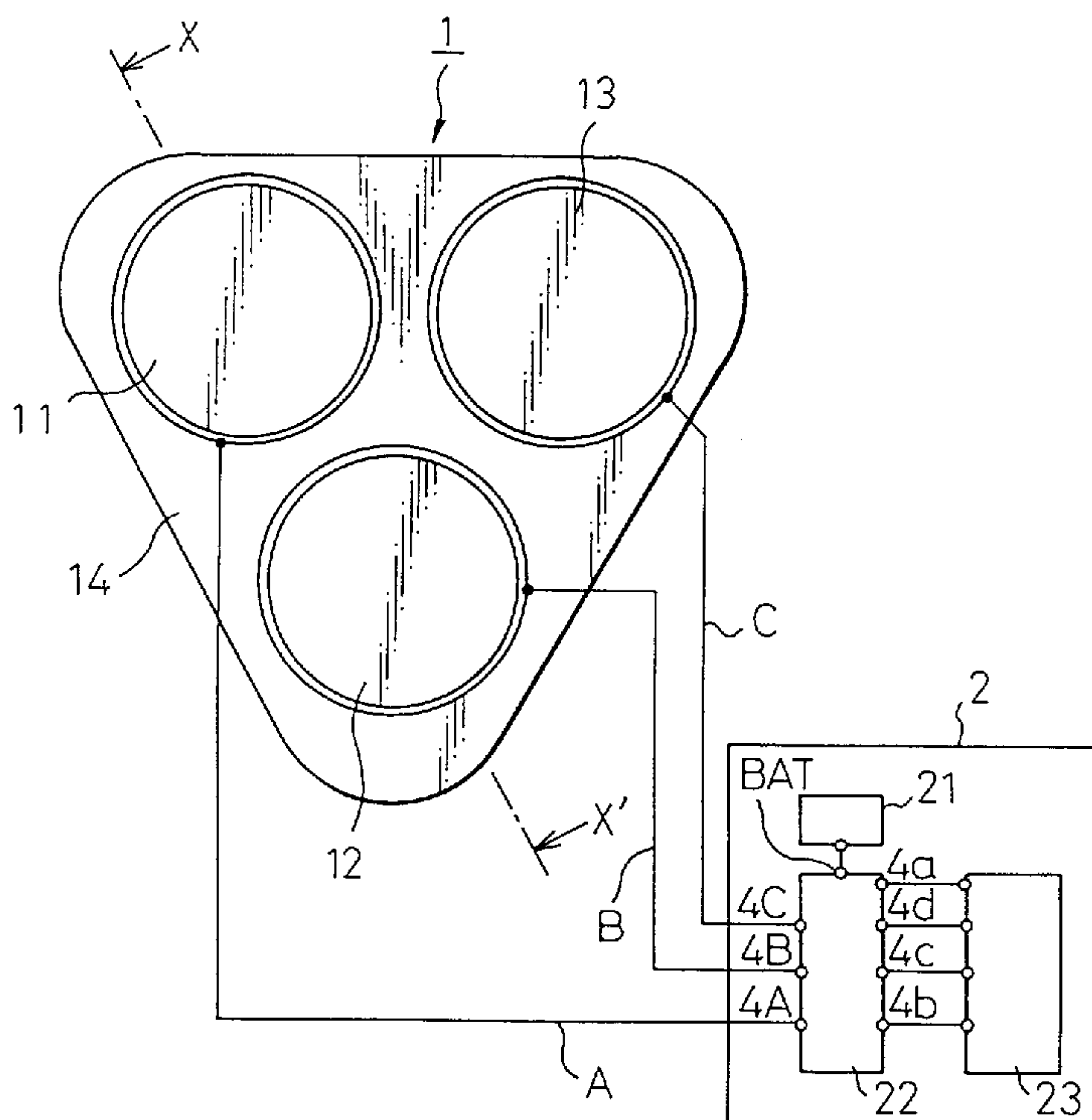

(57) L'invention se rapporte à un système d'iontophorèse, qui comprend un sélecteur de conducteurs et une source de tension dans un circuit d'alimentation pour appliquer une tension pulsatoire entre les conducteurs. Le sélecteur sélectionne des combinaisons de conducteurs en fonction d'une synchronisation prédéterminée, et la source de tension fournit une tension pulsatoire aux combinaisons sélectionnées selon une autre synchronisation. Ainsi, chaque conducteur n'est pas fixé sur un potentiel constant pendant le fonctionnement du système, et une réaction d'électrode indésirable dans les conducteurs peut être évitée.

(57) This invention relates to an iontophoreses system, which comprises a conductor selector and a voltage source in a power supply circuit for impressing a pulsating voltage between conductors. The selector selects combinations of conductors in accordance with a predetermined timing, and the voltage source provides a pulsating voltage to the selected combinations at a different timing. Accordingly, each conductor is not fixed to a constant potential during the operation of the system, and an undesirable electrode reaction in the conductors can be avoided.



2164589

ABSTRACT

This invention relates to an iontophoreses system, which comprises a conductor selector and a voltage source in a power supply circuit for impressing a pulsating voltage between conductors. The selector selects combinations of conductors in accordance with a predetermined timing, and the voltage source provides a pulsating voltage to the selected combinations at a different timing. Accordingly, each conductor is not fixed to a constant potential during the operation of the system, and an undesirable electrode reaction in the conductors can be avoided.

SPECIFICATION

Iontophoresis System

TECHNICAL FIELD

The present invention relates to an iontophoresis system for percutaneously administering a medicine by means of an electric current.

BACKGROUND ART

An iontophoresis system comprises a pair of iontophoretic elements (hereinafter elements) each containing, for example, an ionic drug or medicine, and a power source for applying pulsating voltages to the elements. In the system, the elements are placed on the skin, and then pulsating voltages are applied to the elements. An electrically-closed circuit is thus formed via the skin, whereby a medicine is introduced into a human body. The conductivity of the thus formed electrically closed circuit is dependent greatly on the states of the elements contacting the skin. The electrodes in the elements, which are connected to the power source, are deposited in the same environment as a fluid containing an ionic drug or medicine. Besides, when the system is in operation, voltages that are pulsating in one direction are applied intermittently to the electrodes. Therefore, the electrodes may undergo chemical changes, or electrolysis or adhesion of electrically insulating materials may occur at the surfaces of the electrodes.

The conductivity of the electrically closed circuit therefore deteriorates with the variations of the states of the electrodes in the elements in the system. The persistence of the efficacy of the medication is therefore impaired.

DISCLOSURE OF THE INVENTION

The present invention provides an iontophoresis system in which electrodes in the elements are not susceptible to the influence of

electrode reactions such as chemical changes and electrolysis, and to improve the persistence of efficacy of medication.

5 According to the present invention, an iontophoresis system comprises at least three elements any or all of which contain a medicine, and a power supply means for applying pulsating voltages to any pair of elements so as to generate a potential difference between the pair of elements. The power supply means includes a device
10 selecting means for selecting a combination of elements from among the at least three elements according to a given timing, and a potential difference generating means for generating a potential difference between a selected combination of elements by applying pulsating voltages to
15 the elements over different time periods.

In a preferred embodiment of the present invention, the potential difference generating means preferably generates potential differences between selected combinations of elements by applying a voltage, which is
20 opposite in polarity to the polarity of a voltage applied to at least one of the elements which was selected previously, to the element. The device selecting means preferably selects combinations of elements, in a given order, cyclically.

25 In another preferred embodiment of the present invention, a selected combination of elements is a pair of elements. The potential difference generating means preferably retains any element other than the selected elements in an electrically neutral state.

30 In yet another preferred embodiment of the present invention, the at least three elements are in one package.

According to the foregoing embodiments of the present invention, any combination of elements is
35 selected according to a given timing. A potential difference is generated between combinations of elements by applying pulsating voltages to the elements at

different time periods. The phase of a pulsating voltage to be applied to each element is inverted according to the given timing and the electrodes in the elements are renewed. Thus the aforesaid problem concerning electrode reactions is solved.

When a combination of elements is a pair of elements, the phase of a pulsating voltage to be applied to each element is inverted efficiently and effectively.

Moreover, since any element other than the selected elements is retained in an electrically neutral state, the power consumption of a power source in the system can be minimized.

According to the present invention, the electrodes in the elements can be refreshed and the occurrence of electrode reactions in the electrodes can be avoided or suppressed. This system thus provides stable percutaneous medication for a prolonged period of time.

BRIEF DESCRIPTION OF THE DRAWINGS

The aforesaid and other features and advantages of the present invention will be described in detail in conjunction with the appended drawings.

Fig. 1 is a bottom view showing a first embodiment of an iontophoresis system in accordance with the present invention;

Fig. 2 shows an X-X' section of the system shown in Fig. 1;

Figs. 3(1) to 3(5) are timing charts showing voltages applied to respective components of the system shown in Fig. 1, wherein (1) shows a pulsating voltage supplied from a pulsating voltage producing circuit to elements 11 and 12, (2) shows a pulsating voltage supplied from the pulsating voltage producing circuit to elements 12 and 13, (3) shows a pulsating voltage supplied from the pulsating voltage producing circuit to the elements 13 and 11, (4) shows voltage fluctuations occurring at the elements 11 and 12, and (5) shows voltage fluctuations occurring at the elements 11 and 12

when pulsating voltages are applied according to another method;

Fig. 4 is a circuit diagram showing an example of a pulsating voltage producing circuit in a power supply unit shown in Fig. 1; and

Fig. 5 is a bottom view showing a second embodiment of an iontophoresis system in accordance with the present invention.

BEST MODE FOR CARRYING OUT THE INVENTION

To begin with, the configuration of the first embodiment of an iontophoresis system in accordance with the present invention will be described in conjunction with Figs. 1 and 2.

An iontophoresis system of this embodiment comprises an iontophoretic element unit 1 (hereinafter an element unit) to be placed on the skin of a living body, and a power supply unit 2 for supplying pulsating voltages to the unit 1. The element unit 1 is composed of elements 11, 12, and 13 to be connected to the power supply unit 2 by way of power lines A, B, and C, and an adherent section 14 for retaining the element unit 1 on the skin of a living body by means of adhesion. The elements 11, 12, and 13 and the adherent section 14 are covered with a package 15. The power supply unit 2 includes a power source 21 that is a battery or any other appropriate source, a pulsating voltage producing circuit 22 for producing pulsating voltage outputs, and a control unit 23 for controlling the pulsating voltage producing circuit 22.

In this embodiment, the element unit 1 and power supply unit 2 are separated from each other. Alternatively, the element unit 1 and power supply unit 2 may be integrated into one unit. In this case, the power supply unit 2 must be designed compactly using a button cell and an integrated circuit.

In this embodiment, the elements have the same shape. Each or any of the elements contains a drug or

medicine. The element 11 or 12 is, as shown in Fig. 2, composed of an electrode 111 or 112 connected to the power supply unit 2 and an interfacing member 121 or 122 containing a drug or medicine.

5 The electrodes 111 and 112 are made of a conductive material, preferably, an inactive raw material such as Ag-AgCl. The conductive material is not limited to Ag-AgCl. The interfacing members 121 and 122 are formed with a porous member or a conductive gel. A preferable
10 example of the porous member is a film member having water absorbency or water permeability, for example, a laminated membrane filter (Biodyne A (trade mark)), a nonwoven fabric, a multilayer member made of water permeable fibers; such as, a porous film, starch composed
15 of water-soluble high molecular weight materials and capable of holding, adhering, or encapsulating a given drug or medicine (for example, wafer), or a water-absorbent (or -soluble) film such as a PVP film.

 The degree of the water solubility of a porous
20 member and the content of a drug or medicine in the porous member are specified or adjusted appropriately according to the purpose of the iontophoresis system.

 Next, the operations of the iontophoresis system will be described in conjunction with Fig. 3.

25 After the element unit 1 is placed on an object region for medication on the skin, the power supply unit 2 is energized. The power supply unit 2 applies pulsating voltages, which can be set to any value ranging from several volts to several tens of volts, to the
30 elements 11 and 12 by way of the lead wires A and B respectively. At this time, the power supply unit 2 applies the pulsating voltages so as to cause the potential at the element 11 to go high (positive) and the potential at the element 12 to go low (negative), and
35 thus generates a potential difference between the elements 11 and 12. After applying the pulsating voltages to the elements 11 and 12, the power supply

unit 2 applies pulsating voltages to the elements 12 and 13 by way of the lead wires B and C according to given timing (See Fig. 3(2)). At this time, the power supply unit 2 applies the pulsating voltages so as to
5 cause the potential at the element 12 to go high (positive) and the potential at the element 13 to go low (negative), and thus generates a potential difference between the elements 12 and 13. After applying the pulsating voltages to the elements 12 and 13, the power
10 supply unit 2 applies pulsating voltages to the elements 13 and 11 by way of the lead wires C and A synchronously with a given voltage (See Fig. 3(3)). At this time, the power supply unit 2 applies the pulsating voltages so as to cause the potential at the element 13
15 to go high (positive) and the potential at the element 11 to go low (negative), and thus generates a potential difference between the elements 13 and 11.

Thereafter, the power supply unit 2 repeatedly executes the foregoing sequence of pulsating voltage application by inverting the phase of a pulsating voltage
20 to be applied to each element. Fig. 3(4) shows voltage fluctuations occurring at the elements 11 and 12 during the sequence. Since the phase of a pulsating voltage to be applied to each element is inverted during each period
25 of application, electrode reactions causing the conductivity of each element to deteriorate can be avoided and the occurrence of polarization charge causing a burn can be prevented.

Next, the configuration of the power supply unit 2 producing the aforesaid sequence of pulsating voltages
30 will be described in conjunction with Figs. 1 to 4.

The power supply unit 2 is, as shown in Fig. 1, composed of the power source 21 such as a battery, the control unit 23, and the pulsating voltage producing
35 circuit 22 for producing pulsating voltages in response to a signal sent from the control unit 23.

The control unit 23 can be realized with one or a

plurality of one-chip microcomputers each comprising, for example, a CPU, a clock generator, a voltage divider for producing a pulsating signal of a given frequency on the basis of a clock generated by the clock generator, a
5 memory means for storing a program for executing the sequence of pulsating voltage application and coefficients to be specified in the program, and an interface means for providing an interface with the pulsating voltage producing circuit. The control unit 23
10 feeds a first pulsating signal of a given frequency to an input port 4a of the pulsating voltage producing circuit, and a second pulsating signal, which lags behind the first pulsating signal by a given time, sequentially to input ports 4b to 4d. The first pulsating signal is used
15 to cause the pulsating voltage producing circuit 22 to produce a high voltage. The second pulsating signal is used as a select signal enabling selective application of a pulsating voltage to the elements.

The frequency of the first pulsating signal fed to
20 the input port 4a ranges, for example, from 1 kHz to 10 MHz. The frequency of the second pulsating signal fed to each of the input ports 4b to 4d is, for example, several tens of kHz. These pulsating signals are produced by the voltage divider in the control
25 circuit 23. Alternatively, an oscillator such as a multivibrator may be used for producing the pulsating signals. A pulsating signal having a frequency of 40 kHz and a duty ratio of about 30% is supplied, as an output resulting from phase inversion, to each of the input
30 ports 4b to 4d.

The pulsating voltage producing circuit 22 is, as shown in Fig. 4, composed of a plurality of switching transistors 41 and 44 to 49, an inductor 42, and a capacitor 43. The power source 21 such as a battery
35 shown in Fig. 2 is connected to a terminal BAT of the pulsating voltage producing circuit 22. The elements 11, 12, and 13 are connected to the output ports 4A to 4C by

way of the lead wires A to C.

The operations of the pulsating voltage producing circuit 22 will be described below.

5 When a first pulsating signal is fed to the input port 4a, the transistor 41 is turned on or off synchronously with the pulsating signal. When the transistor 41 is turned on, an excitation current flows into the inductor 42. When the transistor 41 is turned off, a boosted pulse whose level is several times to
10 several tens of times larger than the supply voltage is generated due to the energy released by the inductor 42. The boosted pulse is stored in the capacitor 43 via a diode, and then used as pulsating power to be applied to each element.

15 When a second pulsating signal, that is a select signal, is fed from the control unit to the input port 4b, the transistor 47 is turned on at the leading edge of the select signal. The transistor 44 is turned on synchronously with the transistor 47. The voltage
20 stored in the capacitor 43 is then delivered to each of the output ports 4A and 4B. Thereafter, when the select signal fed to the input port 4b is driven low, the transistors 44 and 47 are turned off. Application of voltages to the elements 11 and 12 via the output
25 ports 4A and 4B is then terminated. Thus, pulsating voltages corresponding to the select signal are applied to the elements 11 and 12.

A given time later, when another select signal is fed from the control unit 23 to the input port 4c, the
30 transistors 45 and 48 are activated. A pulsating voltage causing the potential at the output port 4B to go high is delivered to each of the output ports 4B and 4C. Output pulsating voltages are then applied to the elements 12 and 13.

35 A given time later, when yet another select signal is fed from the control unit 23 to the input port 4d, the transistors 46 and 49 are activated. A pulsating voltage

causing the potential at the output port 4C to go high is delivered to each of the output ports 4C and 4A. Output pulsating voltages are then applied to the elements 13 and 11.

5 Note that since the pulsating voltage producing circuit 22 has the aforesaid circuitry, the potentials at the output ports are inverted with every input of a select signal from the control unit 23.

10 As mentioned above, select signals that lag behind previous signals by given times are consecutively applied to the input ports 4b, 4c, and 4d. A pulsating voltage, whose phase is inverted, is fed sequentially to any pair of the output ports 4A, 4B, and 4C. Consequently, a pulsating voltage whose phase is inverted is applied
15 sequentially to each pair of the elements 11, 12, and 13.

The second embodiment of an iontophoresis system in accordance with the present invention will be described in conjunction with Fig. 5.

20 An iontophoresis system shown in Fig. 5 has four elements. The configuration and inner structure are identical to those shown in Figs. 1 and 2. The description of the configuration and inner structure will therefore be omitted. Any medicine can be contained in each of the elements 51, 52, 53, and 54.

25 The application of pulsating voltages in this embodiment will be described. First, a pair of the elements 51 and 52 is selected with a first select signal fed from a control unit 23' in the power supply unit 2. A pulsating voltage producing circuit 22' applies
30 pulsating voltages to the elements 51 and 52, thus causing the potential at the element 51 to go high (positive) and the potential at the element 51 to go low (negative). With another select signal, a pair of the elements 53 and 54 is selected. Pulsating voltages are
35 then applied to the elements 53 and 54, thus causing the potential at the element 53 to go high and the potential at the element 54 to go low. A pair of the elements 54

and 51 is selected with the next select signal. This causes the potential at the element 54 to go high and the potential at the element 51 to go low. A pair of the elements 52 and 53 is then selected with another select
5 signal. This causes the potential at the element 52 to go high and the potential at the element 53 to go low. By executing the foregoing sequence repeatedly, a pulsating voltage is applied to an element, to which a previous pulsating voltage is applied via an output port
10 whose potential is driven high, via the output port whose potential is driven low. Through the applications of pulsating voltages, the elements are not kept at either a high or a low potential. Electrode reactions causing conductivity to deteriorate can be prevented from
15 occurring at the electrode in each element.

According to the present invention, the number of elements and the way of combining the elements are not limited to those in the aforesaid embodiments. Alternatively, five or more elements may be employed, and
20 a plurality of elements may be paired with one element for the application of pulsating voltages. The configuration required for this alternative will be apparent, from the embodiments, to a person with an ordinary skill in the art. When the number of elements
25 is increased, the numbers of input ports, output ports, and transistors shown in Fig. 4 should be increased accordingly. When a plurality of elements are paired with one element for application of pulsating voltages, a known diode matrix circuit or the like is used to select
30 any of the transistors associated with the input ports and output ports shown in Fig. 4.

The order of applying pulsating voltages to elements, application times, timing, and combinations of elements can be changed by modifying a program written in
35 a microcomputer employed in the aforesaid embodiments. For example, a pulse duration of a pulsating voltage applied to each element may be shortened as indicated

with dashed lines T in Figs. 3(1) to 3(3) and as shown in Fig. 3(5), and then a period between pulses may be regarded as a quiescent period. Owing to the definition of the quiescent period, the power consumption of a power supply unit can be minimized. This results in a compact system.

In the aforesaid embodiments, a plurality of elements are stowed in an element unit. Alternatively, the elements may be formed as stand-alone devices.

Finally, examples of drugs and medicines usable for an iontophoresis system in accordance with the present invention will be listed below.

Local anesthetic

(lidocaine hydrochloride, tetracaine hydrochloride, procaine hydrochloride, dibucaine hydrochloride, oxyprocaine hydrochloride, bupivacaine hydrochloride, mepivacaine hydrochloride, etc.)

Antiallergic agent or antitussant and expectorant

(sodium cromoglycate, ketotifen fumarate, azelastine hydrochloride, amlexanox, terfenadine, emedastine, fumarate, tranilast, codeine phosphate, dihydrocodeine phosphate, eprazinone hydrochloride, tipepidine hybenzate, etc.)

Bronchial dilator

(theophylline, pirbuterol hydrochloride, terbutaline sulfate, hexoprenaline sulfate, salbutamol sulfate, tulobuterol hydrochloride, procaterol hydrochloride, mabuterol hydrochloride, formoterol fumarate, etc.)

Analgesic

(morphine hydrochloride, hydromorphone hydrochloride, buprenorphine hydrochloride, bupranolol hydrochloride, pentazocine, butorphanol tartrate, eptazocine hydrobromide, nalbuphine hydrochloride, etc.)

Cardiac

(dopamine hydrochloride, dobutamine hydrochloride, amrinone, etc.)

Tranquilizer

(chlorpromazine hydrochloride, etizolam, amitriptyline hydrochloride, clocapramine dihydrochloride, haloperidol, mosapramine hydrochloride, perphenazine, etc.)

5 Antibiotic

(penicillin antibiotics such as cloxacillin sodium, benzylpenicillin potassium, ticarcillin sodium, ampicillin sodium, and piperacillin sodium; cefm antibiotics such as cefoxitin sodium, cefodizime sodium, 10 cefotaxime sodium, cefotetan, cefoperazone sodium, cefsulodin sodium, ceftazidime, cefmetazole sodium, and cefpirome sodium; amino sugar antibiotics such as gentamicin sodium, sisomicin sodium, dibekacin sodium, netilmicin sodium, amikacin sodium, and ribostamycin 15 sodium; other antibiotics such as lincomycin, erythromycin, josamycin, chloramphenicol, and tetracycline)

Antimelanoma agent

(mitomycin C, etoposide, procarbazine hydrochloride, 20 tamoxifen citrate, fluorouracil, UFT, tegafur, carmofur, methotrexate, carboquone, bleomycin hydrochloride, peplomycin sulfate, epirubicin hydrochloride, pirarubicin hydrochloride, neocarzinostatin, lentinan, picibanil, sizofilan, cisplatin, carboplatin, adriamycin, 25 vincristine sulfate, etc.)

Circulatory medicine

(nicametate citrate, alprostadiol, argatroban, citicoline, nifedipine fumarate, D-mannitol, nicorandil, diltriazem hydrochloride, etc.)

30 Gout treatment agent

(benzbromarone, allopurinol, colchicine, etc.)

High lipemia agent

(simvastatin, nicomol, pravastatin sodium, etc.)

Antihistamine

35 (diphenhydramine hydrochloride, promethazine hydrochloride, chlorpheniramine maleate, mequitazine, clemastine fumarate, etc.)

Sleep abirritant or antianxiety agent

(flunitrazepam, midazolam, secobarbital sodium, amobarbital sodium, phenytoin sodium, etc.)

Analgesic or antiphlogistic

5 (ketoprofen, flurbiprofen axetil, indometacin, loxoprofen sodium, diclofenac sodium, piroxicam, tenidap, flurbirpfen, tenoxicam, etc.)

Anti-dizziness agent

10 (difenidol hydrochloride, thiethylperazine maleate, beta-histine mesylate, etc.)

Anticonvulsant

(scopolamine buthylbromide, atropine sulfate, eperisone hydrochloride, tizanidine hydrochloride, etc.)

Arrhythmia agent

15 (arotinolol hydrochloride, propranolol hydrochloride, atenolol, quinidine sulfate, indenolol hydrochloride, bucumolol hydrochloride, etc.)

Antihypertensive agent

20 (clonidine hydrochloride, bethanidine sulfate, benazepril hydrochloride, cilazapril, captopril, celiprolol hydrochloride, tilisolol hydrochloride, terazosinn hydrochloride, bunnazosin hydrochloride, carvedilol, etc.)

Cortical hormone

25 (hydrocortisone sodium phosphate, dexamethasone palmitate, dexamethasone sodium phosphate, betamethasone sodium phosphate, methylprednisolone succinate, etc.)

Peptide, polypeptide, and other drugs include luteinizing hormone-releasing hormone (LH-RH),
 30 enkephalin, endorphin, interferon, insulin, calcitonin, thyrotropin releasing hormone (TRH), oxytocin, lypressin, vasopressin, glucagon, pituitary hormone (human growth hormone (HGH), human menopausal gonadotrophin (HMG), human chorionic gonadotrophin (HCG), desmopressin
 35 acetate), follicile stimulating hormone, growth hormone releasing factor, adrenocorticotropic hormone (ACTH), parathyroid hormone (PTH), secretin, angiotensin, beta-

endorphin, somatostatin, gastrin, neurotensin, atrial
natriuretic peptide (ANP), bradykinin, substance P,
dynorphin, thyroid-stimulating hormone (TSH), prolactin,
interleukin, granulocyte colony-stimulating factor (G-
5 CSF), glutathione peroxidase, superoxide dismutase (SOD),
desmopressin, somatomedin, melanocyte-stimulating hormone
(MSH), muramyl dipeptide, bombesin, vasoactive intestinal
polypeptide, cholecystokinin-8, calcitonin gene relating
peptide (CGRP), endothelin, and nicotine.

10 These agents are mixed with various matrix
components available in pharmaceuticals and can be used in
various types of forms such as salve, gel, cream,
solution, suspension, film, or the like.

C L A I M S:

1. An iontophoresis system having at least three iontophoretic elements, any or all of which contains a medicine, and a power supply means connected to the elements for applying pulsating voltages to the elements so as to generate a potential difference between the elements, wherein:

said power supply means includes an element selecting means for cyclically selecting a pair of iontophoretic elements in a given order from among said at least three iontophoretic elements, and a potential difference generating means for generating a potential difference between said selected pairs of iontophoretic elements by applying pulsating voltages to the elements at different time instants;

wherein said potential difference generating means retains any iontophoretic element other than the selected iontophoretic elements in an electrically neutral state;

wherein said potential difference generating means generates a potential difference by applying a voltage to one of the iontophoretic elements of one of said selected pairs of iontophoretic elements such that said voltage pulsates in a direction opposite to a direction of a voltage previously applied to said one of the iontophoretic elements of a previously selected pair; and

wherein said potential difference generating means generates potential differences so that each of any one pair of iontophoretic elements selected from among the at least three elements exhibits a voltage of the same polarity, and so that the polarity of each of the elements is periodically changed to the three states of positive polarity, negative polarity and electrically neutral.

2. The system according to claim 1, wherein said at least three iontophoretic elements are stowed in one package.

3. The iontophoresis system of claim 1 wherein a duty ratio of voltage pulses applied to any one pair of elements selected from among the at least three electrodes corresponds to an

inverse number or less of the number of elements.

4. The iontophoresis system of claim 1 wherein the potential generating means generates positive pulses having a maximum duty cycle equal to $1/n$, wherein n is equal to the number of iontophoretic elements.

5. An iontophoresis system having at least three iontophoretic elements, any or all of which contains a medicine, and a power supply means connected to the elements for applying pulsating voltages to the elements so as to generate a potential difference between the elements wherein:

said power supply means includes an element selecting means for cyclically selecting pairs of iontophoretic elements in a given order from among said at least three iontophoretic elements, and a potential difference generating means for generating a potential difference between said iontophoretic elements of said selected pairs by applying a positive pulse to one iontophoretic element and a negative pulse to the other iontophoretic element of said selected pair and retaining any iontophoretic elements other than the selected pair in an electrically neutral state, wherein said potential difference generating means generates said potential difference so that each of the iontophoretic elements of a selected pair always receives the same polarity pulse when said pair is selected by the element selecting means, each of the iontophoretic elements receiving a periodic waveform comprising a positive pulse, a negative pulse and electrically neutral state.

Fig.1

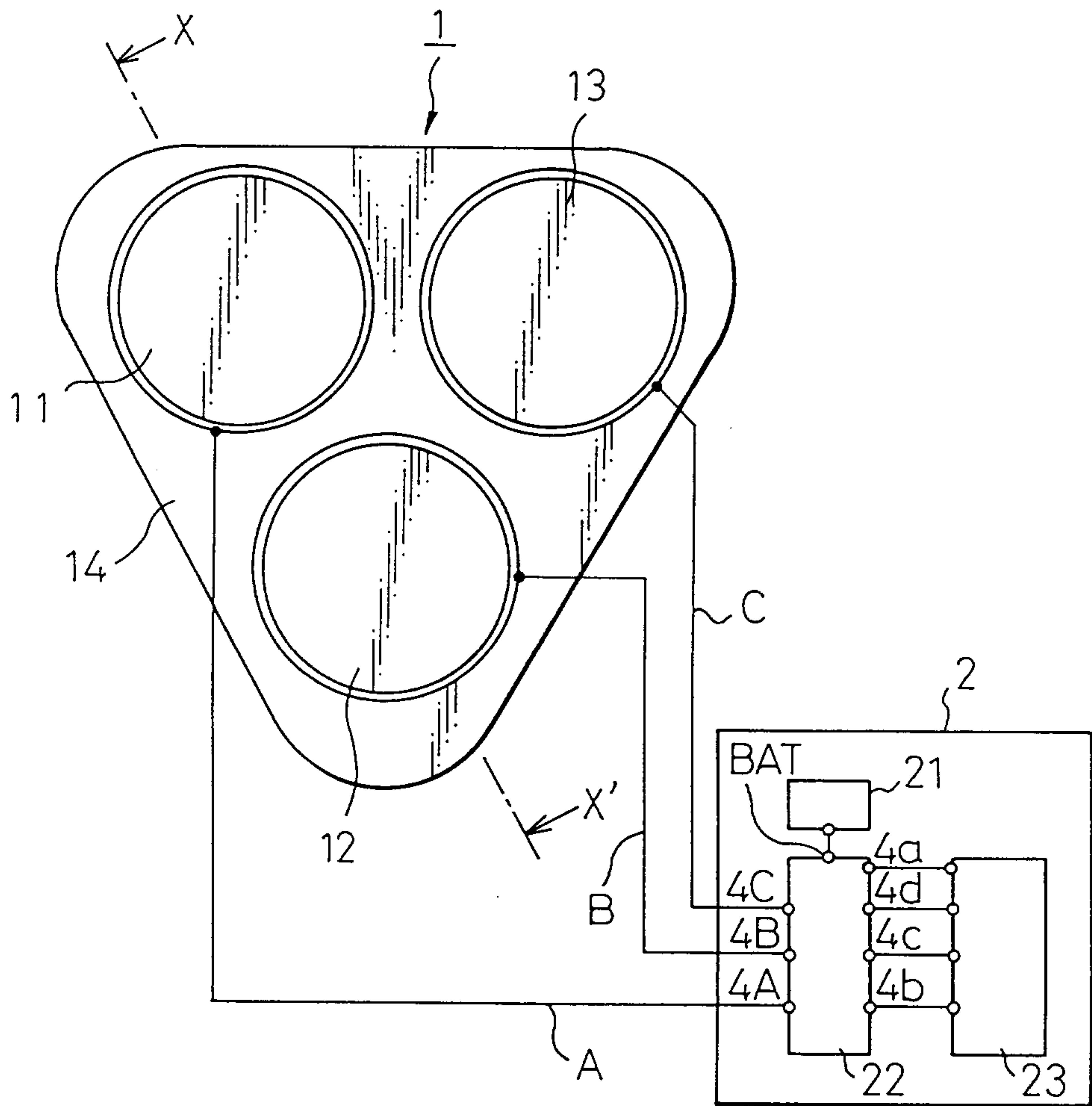
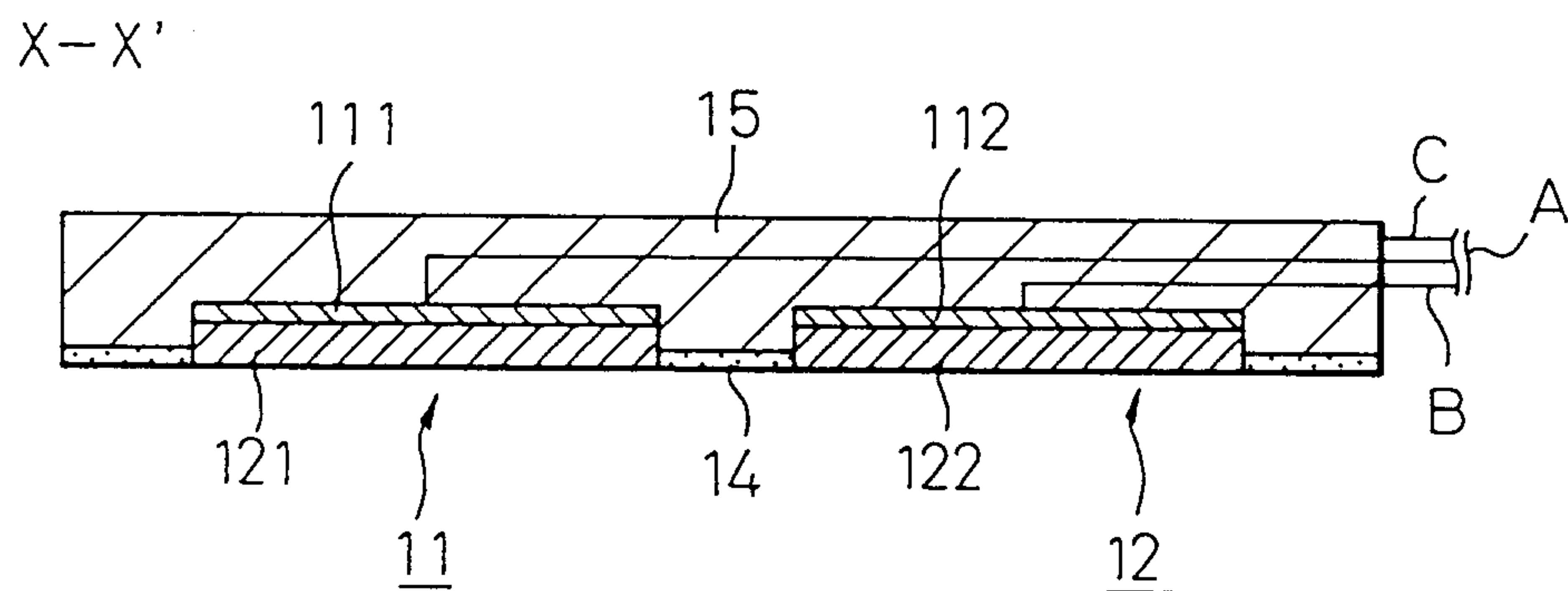

Fig.2



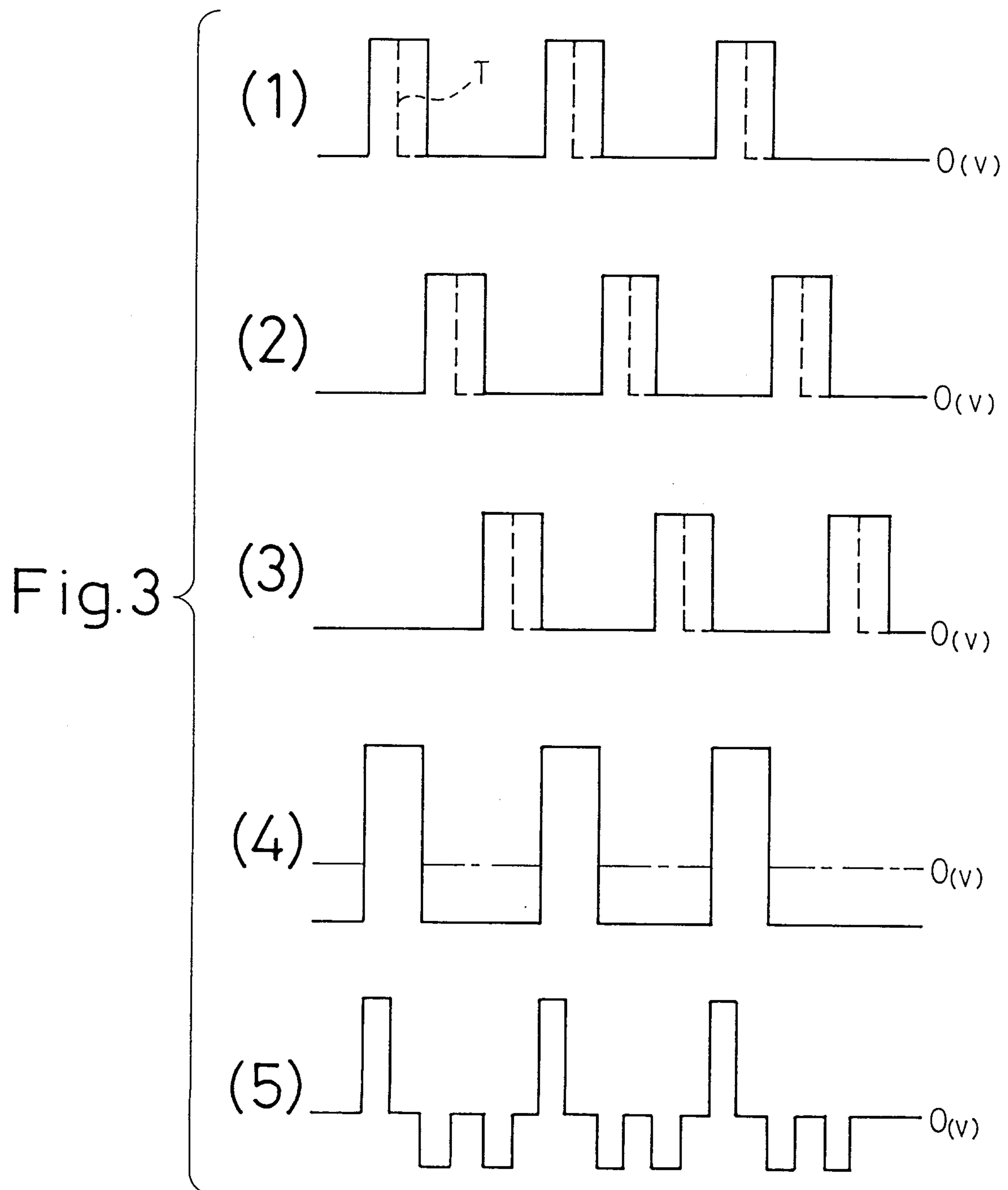

Fig. 4

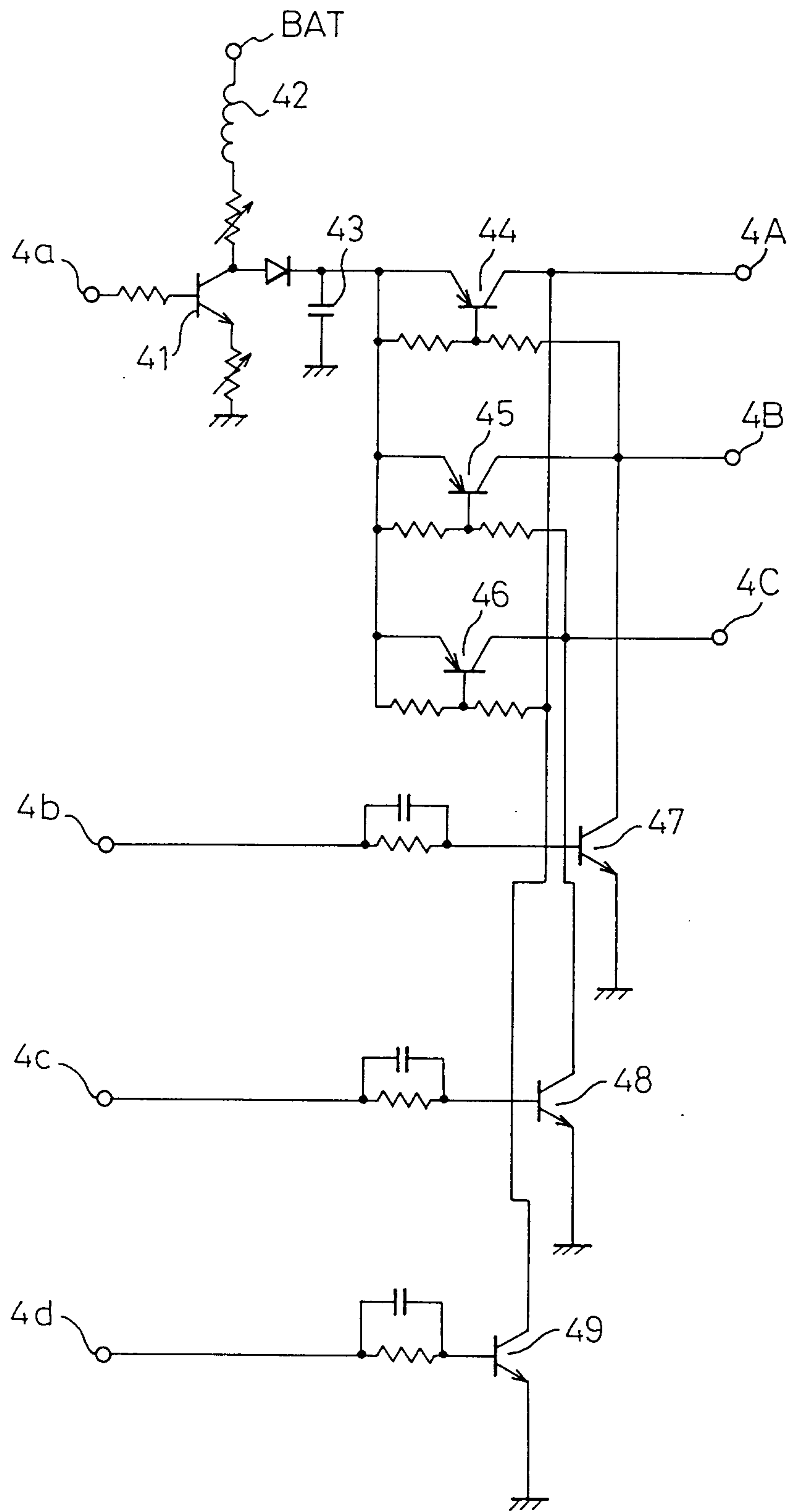
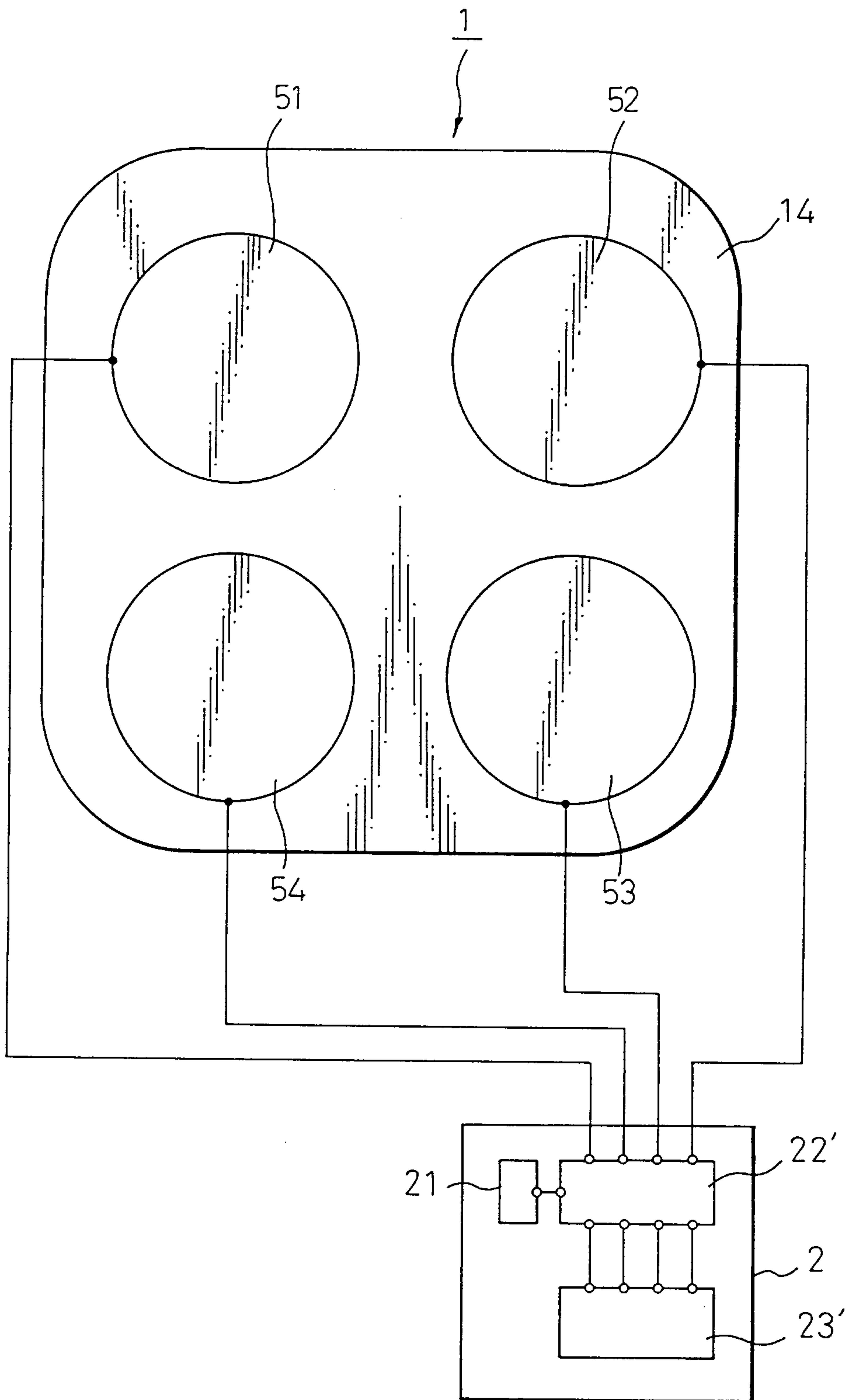

Fig. 5



List of Reference Numerals

- 1 ... iontophoretic element unit
- 2 ... power supply unit
- 11, 12, 13 ... iontophoretic element
- 14 ... adherent section
- 15 ... package
- 21 ... power source such as a battery
- 22, 22' ... pulsating voltage producing circuit
- 23, 23' ... control unit
- 41, 44, 45, 46, 47, 48, 49 ... transistor
- 42 ... inductor
- 43 ... capacitor
- 51, 52, 53, 54 ... iontophoretic element
- 111, 112 ... electrode
- 121, 122 ... interfacing member
- A, B, C ... lead wire

