

**(19) AUSTRALIAN PATENT OFFICE**

(54) Title  
A child's bed

(51)<sup>6</sup> International Patent Classification(s)  
**A47D** 7/00 (2006.01) 20060101AFI2006122  
A47D 7/00 1BHSB  
PCT/SE2006/000534

(21) Application No: 2006258276 (22) Application Date: 2006 .05 .03

(87) WIPO No: W006/135299

(30) Priority Data

(31) Number	(32) Date	(33) Country
0501351-1	2005 .06 .14	SE

(43) Publication Date : 2006 .12 .21

(71) Applicant(s)  
BabyBjorn AB

(72) Inventor(s)  
Bergkvist, Hakan

(74) Agent/Attorney  
Spruson & Ferguson, Level 35 St Martins Tower 31 Market Street, Sydney, NSW, 2000

(56) Related Art  
WO 1992/002161  
US 2646577  
US 3789439  
US 5581827

(12) INTERNATIONAL APPLICATION PUBLISHED UNDER THE PATENT COOPERATION TREATY (PCT)

(19) World Intellectual Property Organization  
International Bureau



(43) International Publication Date  
21 December 2006 (21.12.2006)

PCT

(10) International Publication Number  
WO 2006/135299 A1

- (51) International Patent Classification:  
A47D 7/00 (2006.01)
- (21) International Application Number:  
PCT/SE2006/000534
- (22) International Filing Date: 3 May 2006 (03.05.2006)
- (25) Filing Language: Swedish
- (26) Publication Language: English
- (30) Priority Data:  
0501351-1 14 June 2005 (14.06.2005) SE
- (71) Applicant (for all designated States except US): BABY  
BJÖRN AB [SE/SE]; P.O. Box 595, S-182 15 Danderyd  
(SE).
- (72) Inventor; and  
(75) Inventor/Applicant (for US only): BERGKVIST, Håkan  
[SE/SE]; Beckomberga vägen 72, S-168 54 Bromma (SE).
- (74) Agents: SUNDSTRÖM, Per et al.; Stenhamns Patentbyrå  
AB, P.O. Box 4630, S-116 91 Stockholm (SE).
- (81) Designated States (unless otherwise indicated, for every  
kind of national protection available): AE, AG, AL, AM,  
AT, AU, AZ, BA, BB, BG, BR, BW, BY, BZ, CA, CH, CN,  
CO, CR, CU, CZ, DE, DK, DM, DZ, EC, EE, EG, ES, FI,  
GB, GD, GH, GI, GM, GR, GU, HN, HU, IL, IN, JP, KE,  
KG, KM, KN, KP, KR, KZ, LC, LK, LR, LS, LT, LU, LV,  
LY, MA, MD, MG, MK, MN, MW, MX, MY, NA, NG, NI,  
NO, NZ, OM, PG, PH, PL, PT, RO, RU, SC, SD, SE, SG,  
SK, SL, SM, SY, TJ, TM, TN, TR, TT, TZ, UA, UG, US,  
UZ, VC, VN, YU, ZA, ZM, ZW.
- (84) Designated States (unless otherwise indicated, for every  
kind of regional protection available): ARIPO (BW, GH,  
GM, KE, LS, MW, MZ, NA, SD, SL, SZ, TZ, UG, ZM,  
ZW), Eurasian (AM, AZ, BY, KG, KZ, MD, RU, TJ, TM),  
European (AT, BE, BG, CH, CY, CZ, DE, DK, EE, ES, FI,  
FR, GB, GR, HU, IE, IS, IT, LT, LU, LV, MC, NL, PL, PT,  
RO, SE, SI, SK, TR), OAPI (BF, BJ, CF, CG, CI, CM, GA,  
GN, GQ, GW, ML, MR, NE, SN, TD, TG).
- Declarations under Rule 4.17:**  
— as to applicant's entitlement to apply for and be granted a  
patent (Rule 4.17(ii))  
— as to the applicant's entitlement to claim the priority of the  
earlier application (Rule 4.17(iii))  
— of inventorship (Rule 4.17(iv))
- Published:**  
— with international search report
- For two-letter codes and other abbreviations, refer to the "Guidance  
Notes on Codes and Abbreviations" appearing at the beginning  
of each regular issue of the PCT Gazette.

(54) Title: A CHILD'S BED

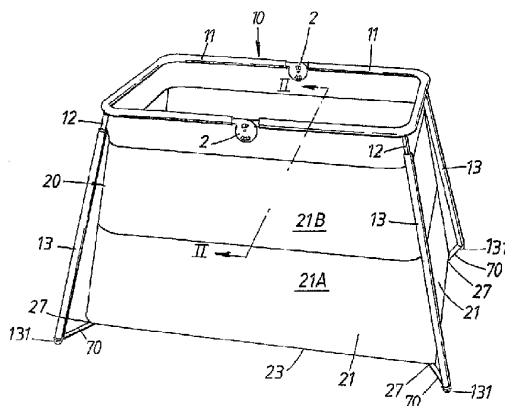

(57) Abstract: A child's bed comprises a sack (20) of a flexible material, which by a bottom (23) rests on the floor and which has the mouth part thereof connected to a rectangular frame (10). The frame (10) is formed of two frame parts, which are mutually connected via folding fittings that allow the frame parts to be folded into a parallel and overlapping relation. The frame (10) is provided with one obliquely outward downward sloping leg (13) in each corner. The legs are possible to fold back against the underside of the respective frame part (11) in order to lie within the area of the frame part. The free end (131) of the respective leg (13) is connected to an adjacent bottom corner (27) of the sack (20) in order to facilitate the folding-out and collapsing, respectively, of the bag (20) in connection with the erection and collapse, respectively, of the child's bed.

WO 2006/135299 A1

2006258276 16 Mar 2011

### A CHILD'S BED

The invention relates to a child's bed.

5 A child's bed of a transportable nature has to be dismountable in order to occupy a small space in a dismounted state. Furthermore, the child's bed should have a low weight and be easy to dismount and assemble, respectively. Furthermore, in the erected state, the child's bed should be stable and have a good child safety.

10 In that connection, the child's bed should comprise a ring-shaped frame that is carried at a distance above a ground by means of dismountable legs and that carries a bed bottom, which is provided with flexible side walls connected to the frame at a considerable distance above the bed bottom, in order to prevent a small child from leaving the bed.

15 It is the object of the present invention to substantially overcome or at least ameliorate one or more of the prior art disadvantages or at least provides a useful alternative.

The present invention in one aspect provides a bed for a child, comprising:  
a ring-shaped frame;  
legs connected to the frame; and

20 a sack of flexible material mounted on the frame with an opening verge part of the sack connected to the frame, a bottom of the sack being configured to (i) rest on a floor on which the legs of the bed, once erected, rest, and (ii) extend over an area that substantially corresponds to an area surrounded by the frame;

a mattress having a bottom area corresponding to the bottom of the sack; and  
25 a rigid integral bottom plate located between the mattress and the bottom of the sack, the bottom plate having two parallel spaced-apart scoring lines which are positioned in a longitudinally central area of the bottom plate and which extend perpendicularly to a longitudinal direction of the bottom plate,

30 the frame including two mutually turnably mounted frame parts with adjacent branch ends of the frame parts being mutually connected to folding fittings which allow the frame parts to be folded between a first end position substantially in a common plane, and a second end position in which the frame parts are parallel and overlapping, and each leg being foldably connected to a leg attachment of the frame, for foldability between a first end position supporting the frame, and a second end position, in which the legs are folded back substantially parallel to the plane of the frame parts,

35 the frame being provided with one leg attachment for each leg, the leg attachment having a conical shape and a leg end connecting thereto having a

corresponding conical complementary surface for releasable attachment to each other, and spring members being provided in order to axially pull together the end of the leg and the leg attachment into connection with each other.

The present invention in another aspect provides a bed for a child, comprising: a ring-shaped frame:

a plurality of legs connected to the frame;

a sack of flexible material mounted on the frame with an opening verge part of the sack connected to the frame, a bottom of the sack being configured to (i) rest on a floor on which the legs of the bed, once erected, rest, and (ii) extend over an area that substantially corresponds to an area surrounded by the frame;

a mattress having a bottom area corresponding to the bottom of the sack; and

a rigid integral bottom plate located between the mattress and the bottom of the sack, the bottom plate having two parallel spaced-apart scoring lines which are positioned in a longitudinally central area of the bottom plate and which extend perpendicularly to a longitudinal direction of the bottom plate,

the frame including two mutually turnably mounted frame parts, with branch ends of the frame parts being mutually connected to folding fittings which enable the frame parts to be folded between a first end position substantially in a common plane, and a second end position in which the frame parts are parallel and overlapping, and each leg being foldably connected to a leg attachment of the frame, for foldability between a first end position supporting the frame, and a second end position, in which the legs are folded back substantially parallel to the plane of the frame parts,

the frame having one of the leg attachments for each of the legs, the leg attachment having a conical shape and a leg end connecting thereto having a corresponding conical complementary surface for releasable attachment to each other, with spring members being provided to axially pull the end of the leg and the leg attachment into connection with each other, and

the folding fittings of the frame being configured to allow the frame parts to be folded against each other into a direction in which the leg attachment of the frame parts are facing each other.

In the following, the invention will be described by way of examples, reference being made to the appended drawings which show a preferred embodiment:

Fig. 1 schematically and perspectively shows a child's bed.

Fig. 2 schematically illustrates a section taken along the line II-II in Fig. 1.

Fig. 3 shows a side view of a folding fitting of the bed frame.

Fig. 4 schematically illustrates a section taken along the line IV-IV in Fig. 3.

- Fig. 5 schematically illustrates a support leg and the connection thereof to the frame, in axial section.
- Fig. 6 schematically shows a planar view of the frame with the legs lowered in the plane of the frame.
- Fig. 7 illustrates the bed according to Fig. 1 in the collapsed state and inserted in a parallelepipedic bag having carrying handles.
- Fig. 1 illustrates a rectangular planar frame 10, which comprises two mutually equal, generally U-shaped frame parts 11, which connect to each other via folding fittings 2, which allow the frame parts 11 to be folded into an overlapping parallel state. At each corner of the frame 10, there is a leg attachment 12 and a leg 13 detachably mounted thereto, which from a planar ground (the floor) carries the frame 10 parallel to the ground in relation to a vertical plane that extends through the frame corners, and the legs 13 are sloped obliquely downward at an angle of approx. 15° in relation to a vertical through the attachment 12.

The frame 10 carries a bed structure of a flexible material shaped in the form of a sack 20. The sack has a bottom 23, which rests on the floor/the ground, and side walls 21, which extend up to the frame 10 and are connected to the same. The walls 21 usually comprise a lower part 21A of opaque fabric and an upper part 21B of a transparent material, for instance a net material. The upper verge part of the sack 20 is folded over from the inside outwards, the folded-over verge part being connected to the upper part of the wall 21 by fastening members, for instance zippers 24 along the respective side of the frame 10. The folded-over portion of the sack also extends around the corners of the frame, while the fastening elements 24 do not extend around the frame corners.

In a preferred embodiment, the fitting 2 may comprise two mutually equal, flat sheet-metal elements 1, which are shown to be composed of a circular main part having a shank projecting tangentially therefrom, which is fixed to the end of the respective frame part 11. The two mutually equal sheet-metal parts 1, 1' abut each other planarly and are mutually coupled to a pivot axis 6, which is shown to have a head 61 at each end. A spring 7 on each side of the fitting is kept in contact with the two elements 1, 1' to normally hold the same in surface

2006258276 16 Mar 2011

abutment against each other. In order to hold the branch ends of the frame parts 11, in the state according to Fig. 1, axially directed against each other and prevent the points of connection of the frame parts from being lowered downward in Fig. 1, each element 1, 1' is shown to have an opening 3, 3' and a countersink 4, 4' connecting in the circumferential direction of the opening. The countersunk portions 4, 4' of the two elements 1, 1' will meet end-to-end in the adjacent opening edges 31, 31' of the openings 4, 4'. By the fact that the countersunk/deformed portions 4, 4' are rounded at the opposite opening edges, the countersunk portions 4, 4' can slide out of the respective opening when the fitting 2 is folded in such a direction that the fittings 2 are lifted upward in relation to the state according to Fig. 1. In doing so, the elements 1' separate in the direction of the axis 6 against the action of the spring elements 7. In Fig. 3, two locking devices are shown established in diametrically opposed areas of the pair of elements 1'.

The leg 13 should be arranged foldable in relation to the frame 7, from a stably folded-out state, to a lowered position near the plane of the respective frame part 11. In this connection, the leg 13 may be connected to the frame part 11 by a hinge device 102 having a pivot axis and having hinge portions 103, 104 connected to each other. By the fact that the legs 13 converge toward each other in the direction upward to a point above the central part of the frame, no blocking of the legs 13 is required in the erected state of the bed, but a blocking is yet preferable, for reasons of safety.

Fig. 5 illustrates a connection between a leg 13 and an attachment 12 of the frame part 11 associated thereto. It can be seen that the attachment 12 is in the form of a metallic sleeve conically tapering toward the free outer end thereof, and that the end part of the leg 13 mating therewith receives a corresponding conical sleeve 15, which with an end flange 15' rests against the end of the leg. The sleeve 15 has also an opposite end flange, which rests around the inner circumference of the tube 13. The sleeve has a recess in the outer circumference thereof, and is fixed in the tube end by means of an indentation 14 in the tube wall, the indentation 14 engaging in the external recess of the sleeve. In Fig. 5, it is seen that a draw element 16 is anchored in the frame part 11 or the attachment 12 and extends through the attachment 12 and has a bent over portion outside the free end of the attachment 12. In the bent-over end of the drawbar 17, a bent-over hook part or loop of a draw element 16 engages, which extends into the tube 13 and is surrounded by a screw compression spring 18. The opposite end of the drawbar 17 is bent over and extends through an opening in a circular washer 19, the diameter of which is somewhat smaller than the inner diameter of the tube 13, and thereby offers a support to the inner end of the spring 18. The outer end of the spring 18 rests against the inner end flange 152

of the sleeve 15. In the shown state according to Fig. 5, the spring 18 is compressed and aims to pull together the tube 13 and the attachment 12. Already upon a small folding-out of the tube 13 (upward in Fig. 5), the spring 18 aims to pull down the end of the leg with the sleeve 15 onto the conical tubular attachment 12 into a mutual stable engagement.

5 Thanks to the conicity, a long and stable axial engagement length is presented between the sleeve and the attachment 12 and the coupling may furthermore simply be released by axial separation.

From Figs. 1 and 2, it can be understood that the free end part 131 of the leg 13 is connected to the respective adjacent bottom corner 27 of the sack by a connecting  
10 element 70, for instance in the form of a flexible band.

In Fig. 2 is also shown that a rigid plate 51 is laid on top on the bottom 23 of the sack 20 and that a mattress 50, for instance a foam-plastic plate, is laid on top of the rigid plate 51.

The bed according to Fig. 1 can readily be collapsed by taking the mattress 50  
15 and the plate 51 out of the sack 20. The plate 51 has two parallel, spaced-apart scoring lines 52 in the longitudinally central area of the plate 51. The bed according to Fig. 1 is then placed upside down on the ground, after which the legs 13 are folded back over the respective frame part 11, after which the frame parts 11 are folded back towards each other by turning in the fittings 2. Next, the collapsed frame with the sack 20 is placed in  
20 the doubled mattress 50 and furthermore the plate 51 is placed in a doubled state outside the mattress 50 as is seen in Fig. 7, after which the parallelepipedic bed package thus put together is placed in a parallelepipedic bag 91 mating therewith, which is shown to have carrying handles 92. Naturally, the bag 91 may also have a cover including a zipper closure.

25 In order to erect the bed to the state according to Fig. 1 from the collapsed state corresponding to Fig. 7, the collapsed frame 10 is taken out, and is oriented with the frame parts 11 vertical and with the fittings 2 upward, after which the operator seizes each of the short ends of the frame and turns apart the frame parts 11. In doing so, the legs 13 will automatically, under the  
30

impact of the spring 18, be folded-out into alignment against the attachments 12 and stably engage the same. Since the upper verge of the sack is attached to the frame 10 and furthermore the bottom corners 27 of the sack are attached to the free ends of the legs 13 by the verge 70, the child's bed immediately and automatically assumes the state shown in Fig. 1 and can  
5 be put down on the floor. After putting in the mattress 50 and possibly the plate 51, the bed is ready to be used.

The claims defining the invention are as follows:

1 A bed for a child, comprising:

a ring-shaped frame;

5 legs connected to the frame; and

a sack of flexible material mounted on the frame with an opening verge part of the sack connected to the frame, a bottom of the sack being configured to (i) rest on a floor on which the legs of the bed, once erected, rest, and (ii) extend over an area that substantially corresponds to an area surrounded by the frame;

10 a mattress having a bottom area corresponding to the bottom of the sack; and

a rigid integral bottom plate located between the mattress and the bottom of the sack, the bottom plate having two parallel spaced-apart scoring lines which are positioned in a longitudinally central area of the bottom plate and which extend perpendicularly to a longitudinal direction of the bottom plate,

15 the frame including two mutually turnably mounted frame parts with adjacent branch ends of the frame parts being mutually connected to folding fittings which allow the frame parts to be folded between a first end position substantially in a common plane, and a second end position in which the frame parts are parallel and overlapping, and each leg being foldably connected to a leg attachment of the frame, for foldability between a  
20 first end position supporting the frame, and a second end position, in which the legs are folded back substantially parallel to the plane of the frame parts,

the frame being provided with one leg attachment for each leg, the leg attachment having a conical shape and a leg end connecting thereto having a corresponding conical complementary surface for releasable attachment to each other, and  
25 spring members being provided in order to axially pull together the end of the leg and the leg attachment into connection with each other.

2. The bed according to claim 1, wherein the legs when being operatively connected to the frame converge toward a common point that is centrally positioned  
30 above the central part of the frame, the legs sloping at an angle of from 5-25° to vertical.

3. The bed according to claim 1, wherein the spring members are arranged to axially bias the leg against the attachment, and the attachment and the leg are axially united by a central flexible element coupled to the spring member.

35

4. The bed according to claim 1, further comprising a conical sleeve fixed in the end of the tubular leg, the sleeve having on an outer circumference thereof a recess, and wherein the wall of the tubular leg is deformed for engagement in the recess of the sleeve for axial locking of the sleeve in the leg.

5

5. The bed according to claim 1, wherein the folding fittings of the frame are arranged to allow the frame parts to be folded against each other into a direction in which the leg attachment of the frame parts are facing each other.

10

6. The bed according to claim 1, wherein the free ends of the legs are connected to an adjacent portion of the sack near the bottom wall of the sack.

15

7. The bed according to claim 1, wherein the frame is rectangular and the support leg is connected to the respective corner area of the frame.

20

8. The bed according to claim 1, wherein spring loading that is exerted by the spring member between the leg and the leg attachment is chosen to produce an automatic stable connection of the leg and the leg attachment when a direction of the leg approaches a direction of the attachment.

25

9. The bed according to claim 1, wherein the opening verge portion of the sack is folded over and around the frame against the outside of the sack and is correspondingly attached along the respective frame piece, the corner area of the frame, and wherein the joint along the respective frame side consists of a zipper.

30

10. The bed according to claim 1, wherein the folding fitting includes two mutually equal hinge elements, which are turnably arranged around a common central pivot axis normal to a plane of the hinge elements, the hinge elements are axially spring-loaded into parallel and surface-extended abutment against each other and the hinge elements have an opening each arranged at a distance from the axis and extending in a circumferential direction, and a protrusion from a plane thereof, adjacent to the opening, following in a direction of circumference, the two ends of the protrusion, which connect to the hinge-element opening, abutting against each other in the end position of the fitting, in which the frame parts are folded-out in a common plane.

35

2006258276 16 Mar 2011

11. The bed according to claim 2, wherein the legs slope at an angle of approximately 15° to the vertical.

12. A bed for a child, comprising:

a ring-shaped frame:

a plurality of legs connected to the frame;

a sack of flexible material mounted on the frame with an opening verge part of the sack connected to the frame, a bottom of the sack being configured to (i) rest on a floor on which the legs of the bed, once erected, rest, and (ii) extend over an area that substantially corresponds to an area surrounded by the frame;

a mattress having a bottom area corresponding to the bottom of the sack; and  
a rigid integral bottom plate located between the mattress and the bottom of the sack, the bottom plate having two parallel spaced-apart scoring lines which are positioned in a longitudinally central area of the bottom plate and which extend perpendicularly to a longitudinal direction of the bottom plate,

the frame including two mutually turnably mounted frame parts, with branch ends of the frame parts being mutually connected to folding fittings which enable the frame parts to be folded between a first end position substantially in a common plane, and a second end position in which the frame parts are parallel and overlapping, and each leg being foldably connected to a leg attachment of the frame, for foldability between a first end position supporting the frame, and a second end position, in which the legs are folded back substantially parallel to the plane of the frame parts,

the frame having one of the leg attachments for each of the legs, the leg attachment having a conical shape and a leg end connecting thereto having a corresponding conical complementary surface for releasable attachment to each other, with spring members being provided to axially pull the end of the leg and the leg attachment into connection with each other, and

the folding fittings of the frame being configured to allow the frame parts to be folded against each other into a direction in which the leg attachment of the frame parts are facing each other.

13. The bed according to claim 12, wherein each of the legs when operatively connected to the frame converges toward a common point that is centrally positioned above a central part of the frame, the leg sloping at an angle of from 5 to 25° relative to a vertical plane.

2006258276 16 Mar 2011

14. The bed according to claim 12, wherein the spring members are configured to axially bias the leg against the leg attachment, and the leg attachment and the leg are axially connected by a central flexible element coupled to the spring member.

5

15. A bed for a child substantially as hereinbefore described with reference to the accompanying drawings.

**Dated 14 March, 2011**

**BabyBjörn AB**

**Patent Attorneys for the Applicant/Nominated Person**

**SPRUSON & FERGUSON**

1/3

Fig. 1

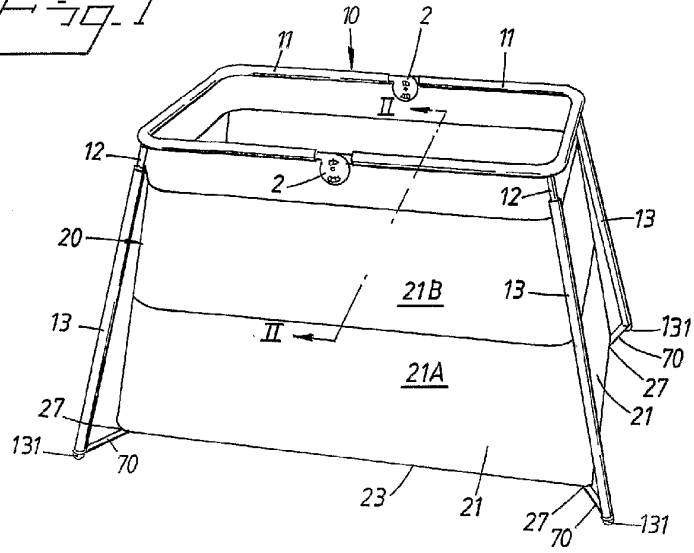
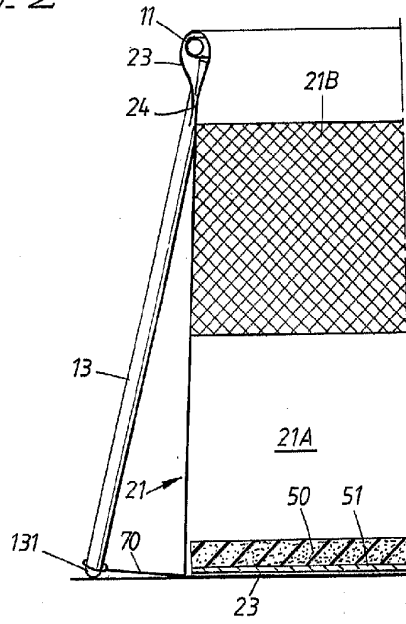

Fig. 2



2/3

Fig. 3

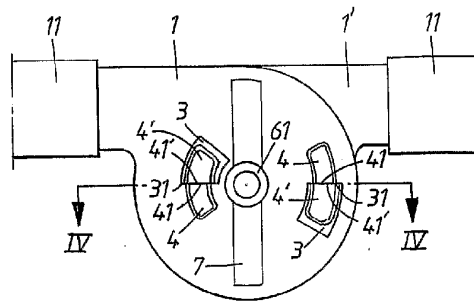

Fig. 4

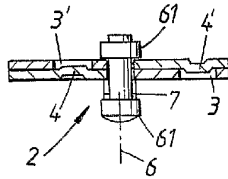

Fig. 5

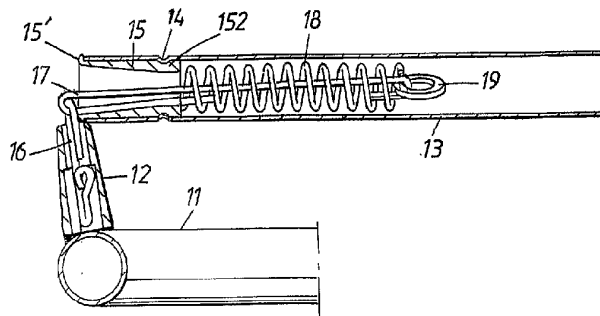

Fig. 6

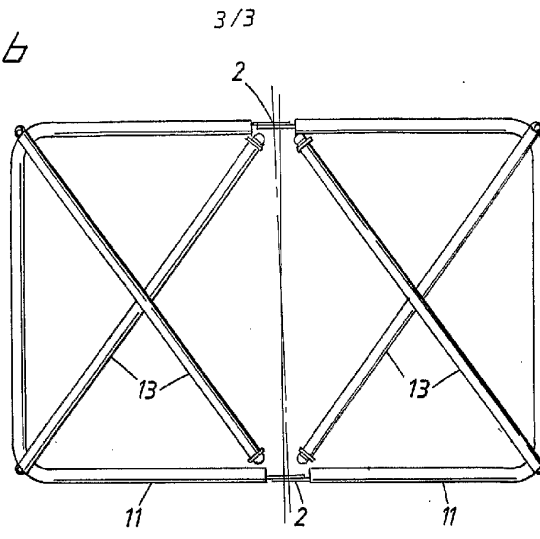

Fig. 7

