

(19) World Intellectual Property Organization  
International Bureau



(43) International Publication Date  
13 February 2003 (13.02.2003)

PCT

(10) International Publication Number  
**WO 03/012152 A1**

(51) International Patent Classification<sup>7</sup>: **C22B 001/14**,  
001/24

**MEAKINS, Ross, Lawrence** [AU/AU]; 531 Chapel Road,  
Bankstown, New South Wales 2200 (AU).

(21) International Application Number: PCT/AU02/01032

(74) Agent: **GRIFFITH HACK**; 509 St Kilda Road, Mel-  
bourne, Victoria 3004 (AU).

(22) International Filing Date: 2 August 2002 (02.08.2002)

(25) Filing Language: English

(26) Publication Language: English

(30) Priority Data:  
PR 6783 2 August 2001 (02.08.2001) AU

(81) Designated States (*national*): AE, AG, AL, AM, AT, AU,  
AZ, BA, BB, BG, BR, BY, BZ, CA, CH, CN, CO, CR, CU,  
CZ, DE, DK, DM, DZ, EC, EE, ES, FI, GB, GD, GE, GH,  
GM, HR, HU, ID, IL, IN, IS, JP, KE, KG, KP, KR, KZ, LC,  
LK, LR, LS, LT, LU, LV, MA, MD, MG, MK, MN, MW,  
MX, MZ, NO, NZ, OM, PH, PL, PT, RO, RU, SD, SE, SG,  
SI, SK, SL, TJ, TM, TN, TR, TT, TZ, UA, UG, US, UZ,  
VN, YU, ZA, ZM, ZW.

(71) Applicants (*for all designated States except US*): **COM-  
MONWEALTH SCIENTIFIC AND INDUSTRIAL  
RESEARCH ORGANISATION** [AU/AU]; Limestone  
Avenue, Campbell, Australian Capital Territory 2612  
(AU). **ROBE RIVER MINING COMPANY PTY LTD**  
[AU/AU]; 9th Floor, St George's Terrace, Perth, Western  
Australia 6000 (AU).

(84) Designated States (*regional*): ARIPO patent (GH, GM,  
KE, LS, MW, MZ, SD, SL, SZ, TZ, UG, ZM, ZW),  
Eurasian patent (AM, AZ, BY, KG, KZ, MD, RU, TJ, TM),  
European patent (AT, BE, BG, CH, CY, CZ, DE, DK, EE,  
ES, FI, FR, GB, GR, IE, IT, LU, MC, NL, PT, SE, SK,  
TR), OAPI patent (BF, BJ, CF, CG, CI, CM, GA, GN, GQ,  
GW, ML, MR, NE, SN, TD, TG).

(72) Inventors; and

(75) Inventors/Applicants (*for US only*): **GANNON, John,  
Francis** [AU/AU]; 1 Skenes Avenue, Eastwood, New  
South Wales 2122 (AU). **SALTER, Celeste, Julienne**  
[AU/AU]; 48 Derain Crescent, Hazelbrook, New South  
Wales 2200 (AU). **VINING, Keith, Richard** [AU/AU];  
6/34 Elizabeth Street, Toowong, Queensland 4069 (AU).

Published:

— with international search report

*For two-letter codes and other abbreviations, refer to the "Guid-  
ance Notes on Codes and Abbreviations" appearing at the begin-  
ning of each regular issue of the PCT Gazette.*

(54) Title: IRON ORE BRIQUETTING

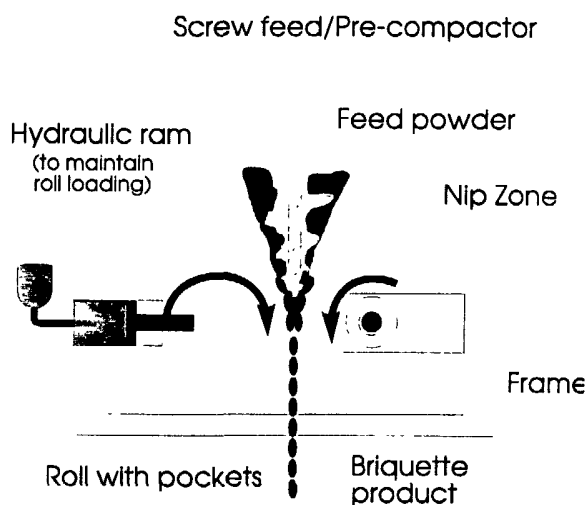

(57) Abstract: A method of producing an iron ore briquette that is suitable for use as a blastfurnace or other direct reduction furnace feedstock which includes the steps of: (1) mixing ore and a flux to form an ore/flux mixture (2) pressing the ore/flux mixture into a green briquette using a low roll pressure; and (3) indurating the green briquette to form a fired briquette.

Schematic of the Taiyo K-102 briquetting press

WO 03/012152 A1

## IRON ORE BRIQUETTING

The present invention is concerned with the production of iron ore briquettes suitable for transport  
5 and use in iron making processes.

Methods of agglomerating iron ores have been in development since the late 1800's. However, of all the available processes only the pelletising and sintering  
10 processes are now of significance, but these suffer from certain disadvantages.

Pelletising consists of two distinct operations; forming pellets from moist ore fines and then firing them  
15 at a temperature in the region of 1300°C. It is critical in order to prepare suitable pellets that the ore be ground very fine, generally to a size where in the order of 60% of the ore passes 45 µm. It is then formed into pellets in either a horizontal drum or an inclined disc,  
20 generally with the addition of a suitable binder. The formed pellets are then fired in a process sometimes referred to as induration in shaft kilns, horizontal travelling grates, or a combination of travelling grates and rotary kilns. Pelletising is a practicable and  
25 commercially attractive method of agglomerating fine concentrates, but requires substantial grinding in order to achieve the required particle sizing which is an energy intensive process. Pellets made from goethite-hematite ores require extended induration times, affecting process  
30 economics. Solid fuel, in the form of coke, is often added to reduce induration time which results in the production of noxious emissions (including dioxins, NO<sub>x</sub> and SO<sub>x</sub>).

Sintering consists of granulating moist iron ore  
35 fines and other fine materials with solid fuel, normally coke breeze, and loading the granulated mixture onto a

permeable travelling grate. Air is drawn downwards through the grate as the temperature is raised. After a short ignition period, external heating of the bed is discontinued and as the solid fuel in the bed burns a narrow combustion zone moves downwards through the bed, each layer in turn being heated to approximately 1300°C. Bonding takes place between the grains during combustion, and a strong agglomerate is formed. However, traditional sintering processes result in high levels of noxious emissions, particularly sulfur oxides and dioxins, and therefore the process is undesirable and unsustainable on environmental grounds.

Briquetting is a process in which there was commercial interest in the late 1800's and early 1900's, but production of iron ore briquettes for use as a blast furnace feed material never reached any significant levels, decreased after 1950, and had ceased by about 1960. The process as practised involved the pressing of ore fines into a block of some suitable size and shape, and then indurating the block. A wide range of binders such as tar and pitch and/or other additives such as organic products, sodium silicate, ferrous sulfate, magnesium chloride, limestone and cement were tested. However, the earliest briquetting process, the Gröndal process, simply involved mixing iron ore with water and pressing into oblong blocks the size of building bricks. These were then hardened by passing them through a tunnel kiln heated to 1350°C.

While developments in briquetting processes have been generally directed towards the development of suitable binders, JP 60-243232 describes briquettes that have a flat shape in order to provide for stable distribution in a blast furnace. Specifically, the Japanese specification discloses that the flat-shaped briquettes are much more easily reduced at higher

temperatures than conventional spherical pellets. The  
briquettes are made with a volume between 2 and 30cc in  
order to balance a relatively high compression strength  
against an inferior rotary or tumble strength and impact  
5 resistance with increasing size. The Japanese  
specification discloses that larger briquettes are less  
easily reduced in a blast furnace. However, aside from  
the size and shape of the briquettes there is no other  
factor described as critical, and, indeed, there is no  
10 detailed description of any other aspect of the production  
of the briquettes.

The applicant has carried out extensive research  
work into the production of briquettes from iron ore and  
15 has invented a method that can produce briquettes that  
have suitable properties for use in blast furnaces and  
other direct reduction vessels.

One of the significant issues that the applicant  
20 has addressed in the research work is that a commercially  
viable iron ore briquette plant must be able to process a  
substantial throughput of material. In order to do this,  
the applicant believes that briquette presses would have  
to be able to process of the order of 70-100 tonnes of  
25 iron ore per hour per press. The applicant found in the  
research work that it was possible to operate briquette  
presses at surprisingly low roll pressures and produce  
green briquettes having sufficient green strength to  
withstand subsequent handling. This was a surprising  
30 finding because information provided by briquette press  
manufacturers indicated that considerably higher roll  
pressures than those found by the applicant to be suitable  
pressures would be required. The finding that low roll  
pressure operation is possible is significant because low  
35 pressure operation makes it possible to use wider presses  
and thereby have higher production rates on the presses.

The present invention is concerned with the selection of briquette forming parameters.

5           According to the present invention there is provided a method of producing an iron ore briquette that is suitable for use as a blast furnace or other direct reduction furnace feedstock which includes the steps of:

- 10   (a)       mixing ore and a flux to form an ore/flux mixture;
- (b)       pressing the ore/flux mixture into a green briquette using a low roll pressure; and
- 15   (c)       indurating the green briquette to form a fired briquette.

          Low pressure operation for iron ore briquetting described in step (b) above is significant and makes it possible to achieve high production rates by the use of wide rolls on the briquetting machine up to 1.6m in length.

25           Preferably the low roll pressure is generated by a roll pressure force that is sufficient to produce briquettes having a green compressive strength of at least 2kgf.

30           Preferably the green compressive strength is at least 4 kgf.

          More preferably the green compressive strength is at least 5kgf.

35           More preferably the green compressive strength is 5-30kgf.

More preferably the green compressive strength is 15-30kgf.

5 Preferably the low roll pressure is generated by a roll pressing force of 10-140 kN/cm on the mixture of ore/flux.

10 More preferably the roll pressing force is 10-60kN/cm.

More preferably the roll pressing force is 10-40kN/cm.

15 Preferably step (a) includes mixing ore having a predetermined particle size distribution of ore particles and flux particles.

20 The predetermined particle size distribution of ore particles that is mixed with flux in step (a) can be produced without grinding ore.

25 Preferably the method includes crushing and screening ore to form the predetermined particle size distribution that is mixed with flux in step (a).

Preferably the top size of the predetermined particle size distribution of ore that is mixed with flux in step (a) is 4.0 mm or less.

30 More preferably the top size is 3.5 mm or less.

More preferably the top size is 3.0 mm or less.

More preferably the top size is 2.5 mm or less.

35

More preferably the top size is 1.5 mm or less.

More preferably the top size is 1.0 mm or less.

5 Preferably the predetermined particle size distribution of ore that is mixed with flux in step (a) includes less than 50% passing a 45  $\mu\text{m}$  screen.

More preferably the particle size distribution includes less than 30% passing the 45 $\mu\text{m}$  screen.

10 More preferably the particle size distribution includes less than 10% passing the 45 $\mu\text{m}$  screen.

Preferably the ore is a hydrated iron ore.

15 Preferably the hydrated ore is a goethite-containing ore.

20 Preferably the flux has a particle size distribution that is predominantly less than 100  $\mu\text{m}$ .

Preferably the particle size distribution of the flux includes more than 95% passing a 250  $\mu\text{m}$  screen.

25 Preferably the flux is limestone.

Preferably the ore/flux mixture produced in step (a) is selected so that the basicity of the fired briquette is greater than 0.2.

30 More preferably the basicity is greater than 0.6.

The term "basicity" is understood herein to mean  $(\% \text{CaO} + \% \text{MgO}) / (\% \text{SiO}_2 + \% \text{Al}_2\text{O}_3)$  of the fired briquette.

35 Preferably there is no binder in the ore/flux mixture.

Preferably the method includes adjusting the water content of the ore prior to or during mixing step (a) to optimise briquette quality and product yield.

5 Preferably the step of adjusting the water content of the ore includes adjusting the water content so that the moisture content of the ore/flux mixture is 2-12% by weight of the total weight of the ore/flux mixture.

10 The term "total weight of the ore/flux mixture" means the total of the (a) dry weight of the ore/flux mix, (b) the weight of the inherent moisture of the mixture, and (c) the weight of the moisture (if any) added to the mixture in the method.

15 The term "moisture content" is the total of (b) and (c) above.

20 Preferably the step of adjusting the water content of the ore includes adjusting the water content so that the moisture content of the ore/flux mixture is 2-5% by weight of the total weight of the ore/flux mixture for ores that are dense hematite ores.

25 Preferably step (b) includes adjusting the water content of the ore so that the moisture content of the ore/flux mixture is 4-8% by weight of the total weight of the ore/flux mixture for ores containing up to 50% goethite.

30 Preferably step (b) includes adjusting the water content of the ore so that the moisture content of the ore/flux mixture is 6-12% by weight of the total weight of the ore/flux mixture for ores that are predominantly, ie  
35 contain more than 50%, goethite ores.

Preferably pressing step (c) produces briquettes that are 10 cc or less in volume.

5 More preferably pressing step (c) produces briquettes that are 8.5cc or less in volume.

10 More preferably pressing step (b) produces briquettes that are 6.5 cc or less in volume.

Preferably indurating step (c) includes heating the briquette to a firing temperature within 40 minutes.

15 More preferably indurating step (d) includes heating the briquette to a firing temperature within 35 minutes.

20 More preferably indurating step (d) includes heating the briquette to the firing temperature within 30 minutes.

More preferably step (c) includes heating the briquette to the firing temperature within 20 minutes.

25 More preferably step (c) includes heating the briquette to the firing temperature within 15 minutes.

Preferably the firing temperature is at least 1200°C.

30 More preferably the firing temperature is at least 1260°C.

More preferably the firing temperature is at least 1320°C.

35 More preferably the firing temperature is at least 1350°C.

More preferably the firing temperature is at least 1380°C.

5 Preferably the fired briquette has a crush strength of at least 200kgf.

Preferably the fired briquette has a crush strength of at least 250kgf.

10

Iron ore fines are broadly characterised into four groups on the basis of petrological characteristics, such as mineralogy, mineral association and particle texture, porosity, size distribution and chemistry. The groups are:

15

Iron ore fines are broadly characterised into four groups on the basis of petrological characteristics, such as mineralogy, mineral association and particle texture, porosity, size distribution and chemistry. The groups are:

20

(a) HC - Dense hematite/magnetite ores;

25

(b) GC - Ores containing up to 50% goethite; and;

(c) G - Ores containing predominantly goethite, ie greater than 50% goethite, such as pisolites, detritals, and channel iron deposits.

30

The following pages of the specification refer to two particular sub-groups of GC ores, namely:

35

(i) HG - goethite-containing ores that are dominated by hematite; and

(ii) GH - ores with approximately equal

amounts of hematite and goethite.

While not wishing to be bound by theory, it is believed that the bonding mechanism in green briquettes involves a combination of bonds including the mechanical interlocking of particles, van der Waal's forces, and in the case of raw material types GC and G, hydrogen bonding to varying degrees is dependent on the percentage of hydrated iron species present, e.g. goethite. Several characteristics of the feed material have been identified as having a significant influence on the formation of such bonds that affect the quality and processing performance of the green and fired briquettes. These characteristics are the moisture level of the feed material and its flow characteristics, the chemical composition of the ore, its size distribution and petrological characteristics and porosity.

Preferably the feed materials are of the widest size distribution possible in order to achieve a high packing density and increased bonding of the ore particles. As noted above, the bonding mechanism of green briquettes is believed to be through a combination of bonds arising from the mechanical interlocking of particles, van der Waal's forces, and hydrogen bonding in the cases of raw material types GC and G. Although a broad size distribution increases the packing density and improves the strength of the green briquette, it is possible to briquette closely sized iron ores.

The top size of the particles is determined by the crushing process but is preferably less than 2.5 mm in order to produce briquettes of acceptable fired properties following the induration process. Generally, ore types HC and HG can be briquetted with coarser top sizes due to the lower heat requirements of these raw materials to attain acceptable fired strength. The top size of the raw

material can be reduced through either crushing or screening processes. The bottom size of the particles has no absolute limit, but it is not necessary or desirable, to grind the ore into very fine particles (as required for pelletising) as this is an additional economic burden rendered unnecessary by the present invention. Preferably less than 10% of the particles pass a 45  $\mu\text{m}$  sieve.

Advantageously the pocket dimensions of the briquetting apparatus should be selected on the basis of the maximum particle size to be briquetted, as well as for adequate induration performance, to ensure that satisfactory briquetting can be achieved. Typically the maximum particle size to achieve satisfactory briquetting is 25-30% of the minimum pocket dimension. If the maximum particle size exceeds this specification it may be necessary to select a larger pocket size.

It is desirable to control feed moisture in order to optimise green briquette quality and product yield. Moisture addition should not exceed the level at which liquid bridging becomes a significant form of inter-particle bonding. This results in both decreased green strength and adversely affects thermal stability. Insufficient moisture can lead to overpressurisation in the briquette pressing step and adversely affect green briquette quality and yield.

Depending on the feed characteristics of the ore to be processed, a moisture content of between 2 and 12 wt % for the feed material is used to optimise green briquette quality and product yield. Dense hematite concentrates (HC) have low optimum briquetting moistures, generally in the range of 2-5 wt %. These concentrates are often made up of closely sized particles with a smooth surface texture that generates low strength briquettes because of decreased interlocking of particles. More

porous goethite-containing ores with up to 50% goethite (GC) briquette well in the range of 4-8 wt % moisture and more porous predominately goethite ores (G) briquette well in the range of 6-12 wt% moisture. Such ores have a rough surface texture and shape enhancing their briquetting characteristics.

Conventional briquetting apparatus may be used in the method of the invention. In essence, such apparatus includes two adjacent rolls with pockets which come together at a nip zone in order to compress the feed material into adjacent, aligned pockets to produce briquettes. In the case of the present invention, the rolls are preferably horizontally aligned to achieve the required throughput for economic feasibility.

Although briquetting can be carried out over a wide range of roll pressures depending on the application, briquetting of iron ores is preferably conducted at roll pressing forces of 10-140 kN/cm and more preferably at the low end of this range, typically from 10-60 kN/cm. As is indicated above, such low pressure operation for iron ore briquetting is significant and makes it possible to achieve high production rates by the use of wide rolls on the briquetting machine up to 1.6m in length.

Preferably the roll pressure is carefully controlled within the low pressure range in order to optimise the briquetting operation. If the roll pressure is too low, the rolls are forced apart producing a thick web and distorted briquettes impairing the product yield and the quality of the briquette, particularly after induration. If the roll pressure exceeds the optimum, poor closure of the briquettes occurs because of the "clamshell" effect on release of the briquettes from the pocket. The clamshell effect is more pronounced for small roll diameters and excess roll pressures, which also cause

pocket binding/jamming. Although the density and crush strength of the green briquettes will be increased, the impact resistance of the fired briquettes will be severely impaired.

5

Preferably the moisture level is selected to influence the flow characteristics of the material through the feed system, and moisture levels of 2-12 wt % for the feed material are generally suitable. If the moisture level is too high for the feed system, the feed pressure is adversely affected resulting in a decreased yield and some impairment of briquette quality, characterised by a lower green strength. If the feed material is too low in moisture for the feed system the resultant feed pressure will cause clamshelling which may result in decreased yields, increased wear rates of the roll pockets, and inferior fired properties.

The briquetting apparatus may be operated with a pre-compactor feed system or with a gravity feed system. The latter system is advantageous where high tonnages are to be briquetted, as in the iron ore industry.

With regard to briquetting presses, a roll diameter is selected in order to ensure that briquette quality is obtained at an economic production rate. Large diameter rolls increase production rates, however they also increase the area of the nip zone. Careful control of the nip zone facilitates formation of quality green briquettes and avoids formation of briquettes with an excessively thick web. Alterations in roll diameter may also alter the optimum moisture level for feed material where increased roll diameters represent increases in feed moisture. Roll diameters typically vary from 250 mm - 1200 mm. In order to maximise production, preferably the rolls are operated at the fastest speed possible whilst maintaining briquette quality. However, a very low roll

speed may be used if productivity is of a secondary concern.

Typically, roll speeds in the range of 1 rpm to  
5 20 rpm are employed. It is desirable in order to maintain  
quality, particularly at high roll speeds, that the feed  
material be presented to the rolls at a rate that matches  
the briquette production rate and with a nip zone area  
that produces the forces required to form quality  
10 briquettes.

Any suitable roll width may be selected provided  
that it is within the pressure capabilities of the  
briquetting machine. As briquetting of iron ores is a low  
15 pressure operation, wide rolls are preferred, increasing  
the capacity of the machine. The rolls are preferably  
horizontally aligned to allow for use with a gravity feed  
system. The flow characteristics of iron ores, whether  
HC, GC (including HG and GH), or G, are suitable for  
20 gravity feeding at the moisture ranges specified above for  
each classification.

The pocket shape should not generally be of a  
sharp angular nature, but be more smooth and rounded to  
25 improve handling characteristics. By way of example, a  
length/width and width/depth ratio of approximately 0.65  
is suitable. Pocket shapes also have specific release  
angles, 110-120° that combat the tendency for sticking in  
the pockets.

30

The pocket size can be optimised according to the  
requirements for the induration process and the raw  
material top size and the iron making blast furnace.  
Typically the briquettes have a volume of between 2 and 30  
35 cc. Preferably the volume is 10 cc or less. More  
preferably the volume is 8.5 cc or less. More preferably  
the volume is less than 6.5 cc.

A staggered pocket configuration is preferred as this makes the optimum use of the available space on the face of the rolls, and hence maximises throughput.

5

Preferably the induration method and conditions are selected having regard to the complex relationship between raw material characteristics and the influence of the briquette dimensions.

10

Consideration of the relationship between briquette volume, shape and the petrological characteristics of the raw material is required. The chemical composition of the feed material will have a significant influence on the properties of the fired briquette. Apart from moisture, the feed material includes the iron ore made up of iron oxide and gangue minerals, with the required flux added to give the required basicity level in the fired briquette. Test results have shown that the flux should preferably be finely sized, typically >95% passing 250  $\mu\text{m}$ , in order to achieve the required properties in the fired briquette.

15

20

While not wishing to be bound by theory, it is believed that the bonding mechanism for fired briquettes involves diffusion bonding and re-crystallisation of the iron oxide particles as well as slag bonding at higher flux levels. Therefore, flux level and firing temperature and, to a certain extent, firing time have a strong influence on briquette properties. Elevated basicity levels may improve reduced strengths as well as indurated strengths as higher flux levels encourage the formation of bonding phases which resist deformation under reducing conditions.

25

30

35

Induration may be carried out using a straight grate, grate-kiln or a continuous kiln type process.

It has been found that green briquettes produced under optimised conditions are thermally very stable compared to pellets prepared from the same material. The  
5 feed ore for pelletising must be ground to a fine size, typically up to 60% passing 45  $\mu\text{m}$ , and the pellets dried slowly at low temperatures, typically  $<200^{\circ}\text{C}$  to avoid spalling. In contrast, as indicated above, the feed ore for the present invention that can be indurated  
10 successfully can be much coarser, with top sizes preferably up to 2.5 mm, and hence does not need grinding to the same extent as is required to produce pellets. This characteristic represents major capital cost reductions for briquetting operations over traditional  
15 pellet production plants.

An important characteristic of the briquette of the present invention is an ability to withstand high temperatures on heating at fast rates, such as heating to  
20 a firing temperature within 30 minutes, more preferably within 20 minutes. This is in direct contrast with conventional understanding of how goethitic ores respond in induration situations, where it has been shown that they spall when heated too fast through the  
25 dehydroxylation and free water removal zones.

As is indicated above, the thermal stability of the briquettes of the present invention has been found to be much greater than pellets and they may be heated at  
30 much faster rates than pellets without spalling. This allows a much shorter heating cycle. Consequently, briquette productivity can be significantly higher than for pellets using the same material. For instance, briquette productivities potentially in the order of  
35  $30\text{t}/\text{m}^2\cdot\text{day}$  in a straight grate kiln can be achieved, compared to pellet productivities of  $16\text{t}/\text{m}^2\cdot\text{day}$  for HG ores in the same kiln.

It will be clearly understood that, although prior art publications are referred to herein, this reference does not constitute an admission that any of these documents form part of the common general knowledge in the art, in Australia or in any other country.

Preferred embodiments of the present invention will now be described, by way of example only, with reference to the accompanying drawings, in which:

FIG. 1 is a schematic illustration of suitable apparatus with 250 mm diameter rolls and a precompacted feed system for conducting the process of the present invention;

FIG. 2 is a schematic illustration of suitable apparatus with 450 mm diameter rolls and a gravity feed system for conducting the process of the present invention;

FIG. 3 is a schematic illustration of suitable apparatus with 650 mm diameter rolls and a gravity feed system for conducting the process of the present invention;

FIG. 4 is a plot of yield of whole briquettes versus feed moisture for HG material on 450 mm rolls with 6 cc almond forms and 4 cc elongate almond pockets;

FIG. 5 is a plot showing the effect of feed moisture on green briquette strength for HG material on 450 mm rolls with varying pocket dimensions;

FIG. 6 is a plot showing the effect of feed moisture on green briquette strength for HG material using

650 mm rolls and 7.5 cc 'pillows';

FIG. 7 shows the effect of roll pressing force on  
briquette properties; thickness, green strength and green  
5 density on 450 mm rolls and 9 cc almond forms;

FIG. 8 is a plot showing the effects of roll  
pressing on green strength for HG material using 650 mm  
10 rolls and 7.5 cc 'pillows';

FIG. 9 is a plot showing the effect of roll  
pressing force on green strength for GH material using 650  
mm rolls and 7.5 cc 'pillows';

FIG. 10 shows the effect of roll speed on  
briquette properties; thickness, green strength and green  
15 density for a rolls pressure of  $90\text{kg/cm}^2$  and a feed  
moisture of 6 wt % using 450 mm rolls and 9 cc almond  
forms;

FIG. 11 is the operating window for a briquetting  
20 machine with a pre-compactor, 250 mm rolls, 4 cc almond  
forms and HG material;

FIG. 12 shows temperature profiles for briquette  
25 induration in a 500 mm deep bed;

FIG. 13 shows temperature profiles for briquette  
induration that produced briquettes at high productivities  
30 and a typical temperature profile for pellet induration  
that produced pellets at a lower productivity;

FIG. 14 is a plot showing the effect of average  
bed temperature on briquettes made with GH material using  
35 650 mm rolls and 7.5 cc 'pillows' at the end of a grate  
cycle in a batch grate kiln;

FIG. 15 is a plot showing the effect of average bed temperature on briquettes made with GH material using 650 mm rolls and 7.5 cc 'pillows' at the end of a grate-kiln firing cycle in a batch grate kiln;

5

FIG. 16 is a plot showing the effect of time at firing temperature (1380°C) on briquettes made with GH material using 650 mm rolls and 7.5 cc 'pillows' during a test cycle in the batch grate kiln;

10

FIG. 17 is a plot showing the effect of time at firing temperature (1380°C) on briquettes made with GH material using 650 mm rolls and 7.5 cc 'pillows' during a test cycle in the batch grate kiln;

15

FIG. 18 is a plot showing the effects of residence time on 7.5 cc GH briquettes in the kiln during a test cycle in the kiln only.

20

FIG. 19 is a plot showing the effect of bed height and grate firing profile on briquettes made with GH material using 650 mm rolls and 7.5 cc 'pillows' during a test cycle in the batch grate kiln;

25

FIG. 20 is a plot showing the effect of bed height and grate firing profile on briquettes made with GH material using 650 mm rolls and 7.5 cc 'pillows' during a test cycle in the batch grate kiln;

30

FIG. 21 shows the effect of basicity and firing temperature on the fired crush strength of briquettes made with HG material, 250 mm rolls and 4 cc almond forms;

35

FIG. 22 shows the effect of basicity on the briquette reduced properties; swell, crush strength after reduction (CSAR) and reducibility index of briquettes made with HG material, 250 mm rolls and 4 cc almond form;

## EXAMPLE 1

Briquetting was performed using three different  
5 roll presses with varying roll diameter, width and feed  
systems.

Initial testing was conducted using a Taiyo K-  
102A double roll press, which has a nominal capacity of  
10 300 kg/hr. This machine has 250 mm diameter rolls of 36  
mm width and features a screw-type precompactor. A  
schematic showing its main components can be seen in  
Figure 1.

15 The briquettes produced were pillow-shaped with  
nominal dimensions of 13x19x28 mm and a volume of 4 cc.  
There was a single row of 30 pockets around the  
circumference of each roll.

20 Of the two rolls, one was fixed whilst the other  
"floating roll" was held against the fixed roll by an oil  
and gas filled ram. The oil in the ram was pressurised to  
provide the desired load force between the rolls.

25 Briquetting was also performed using a Komarek  
BH400 double roll press, with a roll diameter of 450 mm  
and a roll width of 75 mm. Feed material was gravity fed  
into the nip zone from a feed hopper located above the  
rolls. A schematic of its main components can be seen in  
30 Figure 2.

Briquettes of varying dimensions were produced  
with the following details:

35 (1) Nominally 17.5x28x34.3 mm with a volume of  
8.9 cc. There was a double row of 48 pockets arranged in  
staggered alignment around the circumference of each row

(9 cc Almond forms).

(2) Nominally 14.5x22.1x33.9 mm with a volume of 6.3 cc. There was a double row of 60 pockets arranged in a staggered alignment around the circumference of each roll (6 cc Almond forms).

(3) Nominally 15.2x21.7x22.9 mm with a volume of 3.9 cc. There was a triple row of 58 pockets arranged in a staggered alignment around the circumference of each row (4 cc spherical).

(4) Nominally 11.2x17.3x32.1 mm with a volume of 3.9 cc. There was a double row of 72 pockets arranged in a symmetrical alignment around the circumference of each roll (4 cc elongate).

Of the two rolls, one was fixed whilst the other "floating roll" was held against the fixed roll by an oil and gas filled ram. The oil in the ram was pressurised to provide the desired specific pressing force between the rolls.

Briquetting was also conducted using a Köppern 52/6.5 double roll press with a diameter of 650 mm and a roll width of 130 mm. Feed material was gravity fed into a nip zone from a hopper located above. Nip zone area was controlled through use of a 'nip zone adjuster'. A schematic of its main components can be seen in Figure 3.

The briquettes produced were 'pillow' shaped with nominal dimensions of 30x24x16 mm and forms a volume of 7.5 cc. There were four rows of 77 pockets arranged symmetrically across the face of the roll.

Of the two rolls, one was fixed whilst the other "floating roll" was held against the fixed roll by an oil

and gas filled ram. The oil in the ram was pressurised to provide the desired specific pressing force between the rolls.

5 EXAMPLE 2

The effect of feed moisture content was investigated.

10 Figure 4 illustrates that feed moisture had a significant effect on the yield of 6 cc and 4cc briquettes produced by the briquetting press with 450 mm rolls as described in Example 1. The feed material was gravity fed to the rolls while the rolls operated at a fixed roll  
15 speed of 20 rpm and a roll pressure of 90kg/cm<sup>2</sup>.

Feed moisture control is also important as variation in moisture content affects green properties  
20 such as green strength, abrasion resistance and shatter strengths. This is illustrated in Figures 5 and 6.

Figure 5 shows the relationship between feed moisture level and strength for briquettes made with HG  
25 using the 450 mm rolls, a gravity feed system, and a variety of pocket sizes.

Figure 6 shows the same relationship for briquettes made with the 650 mm rolls and 7.5 cc pockets  
30 for HG material.

Green strength tended to increase to a maximum for the optimum moisture content of approximately 6%. At moisture levels exceeding 7.5% the green strength was  
35 unacceptably low.

Feed moisture had less of an influence on shatter strength and the green abrasion resistance of the briquettes.

5 EXAMPLE 3

As is indicated above, although briquetting operations can be carried out over a wide range of rolls pressures, it is preferred that briquetting be carried out  
10 at low pressures. Such low pressure operation for iron ore briquetting is significant and opens up the possibility of achieving high production rates with wide rolls on a briquetting machines.

15 However, as is indicated above, roll pressure should be carefully controlled within this low pressure range if the briquetting operation is to be optimised. If roll pressure is too low and nip zone area is not carefully controlled, the rolls are forced apart producing  
20 a thick web and distorted briquettes impairing the product yield and the quality of the briquette, particularly after induration. If roll pressure exceeds the optimum, poor closure of the briquettes occurs because of the "clamshell" effect on release of the briquette from the  
25 pocket. Although the density and crush strength of the green briquette will be increased, the impact resistance of the fired briquette will be severely impaired.

Figure 7 shows the effect of roll pressure on  
30 briquette thickness and quality (measured in terms of crush strength) for raw material HG produced in a gravity fed machine with 450mm diameter rolls with nominal 9 cc pockets. The figure shows that acceptable green strength was obtained at roll pressures as low as 60 kg/cm<sup>2</sup>.

35

Figures 8 and 9 show the effect of pressing force and resultant green strength that was obtained using the

650 mm diameter rolls. The work was carried out on HG and GH raw material types and illustrates a similar relationship between roll pressure and green strength as with the 450 mm work. Specifically, the figures show that acceptable green strengths were obtained at pressing forces of 20 kN/cm.

Pressing force was also found to exert a significant influence on the shatter strength and the green abrasion resistance of the briquettes, with both variables increasing in response to increased roll pressure.

#### EXAMPLE 4

Roll speed was also investigated.

Roll speed, measured in rpm, was found to exert an influence on the amount of pressure applied to feed materials.

Increased roll speeds result in shorter residence time in the nip zone of the rolls and hence lower pressure is exerted for a longer period of time. Roll pressure can be used primarily to control the amount of pressure exerted on feed material and roll speed can be altered to maximise the production rate. However, it is important to consider the effects of roll speed on briquette thickness and green strength when optimising the green briquetting operation.

The effect of roll speed on briquette thickness and quality (measured in terms of crush strength) for raw material HG is shown in Figure 10 for a gravity fed machine with 450 mm diameter rolls.

The Figure shows that thickness and green strength decreased as roll speed increased.

#### EXAMPLE 5

5

The process variables of the briquetting machine as described in Example 1, ie, roll speed, precompactor speed and roll pressure, and the briquette density were used to determine an operating window for this particular system of briquetting.

10

The diagram shown in Figure 11 is an example of an operating window for briquetting with 250 mm rolls to form nominally 4 cc briquettes out of HG material on the Taiyo press.

15

To simplify the curves, roll pressure was fixed at 150 kg/cm<sup>2</sup> and precompactor speed was fixed at 20 rpm. A series of curves are shown for feed moisture from 4 wt % to 12 wt %. Each represents conditions that resulted in the formation of whole briquettes.

20

To the right of the curves there is a region of low feed pressure where pockets are not filled or the briquettes are weak and split readily. To the left of the curves there is a region where the pressure on the feed is too high. Briquettes shear and pocket blockage occurred. Across the strength range, below 6 kgf, the briquettes were too weak to withstand pocket release and either remain in the pockets or split on release. Above 30 kgf, further compaction could not be achieved. The briquettes were thick and began to 'clam shell'. The strength range of 6 to 30 kgf defined the outer limits within which whole briquettes could be formed with the sample material and the Taiyo briquetting machine.

30

35

To determine the operating window certain product and quality parameters including yield, density, crush strength and drop/shatter strength need to be considered. Once these properties are taken into consideration, a smaller region can be defined which is the operating region of the briquetting process.

In Figure 11, this region occurs at rolls speeds between 5 and 9 rpm and green strengths between 6 kgf and 18 kgf.

#### EXAMPLE 6

Green briquettes produced under optimised conditions were found to be thermally very stable compared to pellets formed from the same material. This is shown in Figures 12 and 13.

Figure 12 shows the temperature profiles for the inlet and outlet gas and three positions within the bed of briquettes during laboratory-scale induration trials simulating a straight grate process.

The bed temperatures were measured by thermocouples placed at 100, 250 and 500 mm from the top of the bed.

The briquettes were found to be thermally stable when heated at fast rates shown in the figures. The excellent drying performance allowed the inlet gas temperature to be raised from ambient to 1340°C in ten minutes without spalling the briquettes.

Figure 13 shows the temperature profiles for briquette induration that produced nominal 4 cc briquettes of HG ore at productivities of 32 t/m<sup>2</sup>.d and 25 t/m<sup>2</sup>.d. The figure also shows, by way of comparison, a typical

induration temperature profile for pellets. The pellet profile was an optimised profile so that pellet spalling was minimised and fired properties were maximised. The pellet profile produced pellets with a productivity of 5 16t/m<sup>2</sup>.d, which is considerably lower than the productivities of the briquettes. The briquettes and the pellets were made from the same ore type.

The high productivities for the briquettes was 10 due to the thermal stability of the green briquettes which enabled the briquettes to be heated at fast rates.

The thermal stability of the briquettes was found to be not exclusive to one induration method and to one 15 ore type.

#### EXAMPLE 7

A pilot scale grate-kiln system was used to 20 determine the properties of briquettes as they exited a grate prior to entry to a kiln.

The equipment consisted of a pot grate and a batch kiln. To simulate the travelling grate a LGP gas 25 burner was used to generate the flame temperature. The pot grate was capable of up and down draught gas flow. The temperature of the material was measured throughout the bed using thermocouples set into and through the wall of the pot. These measurements were assumed to be the 30 briquette temperature during the firing cycle. Due to the size of the briquettes tested, it may be that the temperature measurement shows the external briquette temperatures and not the internal temperatures. The temperature measured is most likely a mixture of briquette 35 outside temperature and gas temperature at that location in the bed.

Figure 14 shows how the temperature of the briquettes made from GH material ( $d_{95} = 1\text{mm}$ ) with a green nominal size of 7.5cc initially increased to a maximum at approximately 300-400°C average bed temperature, and then  
5 fell to a minimum temperature at ~700°C. At higher temperatures the strength then increased again. The strength fell to a minimum value at ~700°C, which is lower than the green strength. This is a critical factor for transport of the material from the grate-to the kiln. As  
10 the strength was lowest at this temperature range, the maximum amount of degradation could be expected if the firing profile included transfer from the grate to the kiln at this temperature.

15 For a straight grate process, the bed height selected for the induration process was found to be not critical and not inhibited by gas permeability generally selected to avoid deformation of the briquettes at the lower parts of the bed while achieving a reasonable  
20 productivity. In addition, at briquette volumes exceeding 6 cc, permeability of the bed was not greatly compromised by bed height. Consequently, the induration process is not restricted by this variable as is the case with  
pelletising operations. Green briquette bed depth can be  
25 selected to optimise productivity without compromising quality.

A grate-kiln process may offer certain advantages in terms of producing a better fired product compared to  
30 products obtained from other induration processes. It also heats the briquettes more uniformly through high temperature ranges in a way that reduces temperature gradients within the briquette and avoids differential shrinkage of the briquette that may lead to cracking.  
35 Also, as all the briquettes are subject to similar firing temperatures and time in the rotating kiln, briquette quality is more uniform compared to the straight grate

process.

Possibilities also exist for the production of  
briquettes suitable for direct reduction processes,  
5 providing a raw material of a suitable grade is used.

#### EXAMPLE 8

Firing temperature was investigated.

10

Briquettes of GH material (d95 = 1mm) 7.5cc were  
fired in the grate-kiln pilot rig, all using the same  
firing profiles for the grate section. After transfer to  
the kiln, the same profile was applied for firing, except  
15 that the firing temperature reached was altered as shown.  
The results are shown in Figure 15.

There is a clear indication in Figure 15 that to  
achieve suitable fired strength in briquettes of this size  
20 the firing temperature in the kiln should be at least  
1380°C.

Figure 15 also shows that tumble strength (Tumble  
Index - TI) and abrasion resistance (Abrasion Index - AI),  
25 improved with firing temperature.

#### EXAMPLE 9

Firing temperature and time at temperature were  
30 investigated.

Briquettes made from GH material (d95 = 1mm) with  
a nominal size of 7.5cc were fired in a series of grate-  
kiln tests. The grate firing profile was the same, with  
35 only the firing time in the kiln at the firing temperature  
being changed from 6 to 9 minutes. The total firing time  
in the kiln remained the same, the extra time for the

firing was taken from the rate of heating in the kiln, so that the 9 minutes firing time had a quicker heating rate to 1380° compared to the 6 minutes firing time.

5                   Tests were also conducted with 6.3cc GH  
briquettes using the same firing profile as that used for  
the 7.5cc case.

Results are illustrated in Figures 16 and 17.

10

For the nominally 7.5cc size GH briquettes, the fired strength increased significantly from the longer firing time in the kiln. This was due to greater heat penetration of the briquettes during the firing cycle.

15

The fired properties for the 6.3 cc GH briquettes were superior to those produced for the 7.5cc case, inferring that the issue of heat penetration is a significant issue for fired property generation of the  
20                   briquettes. This result also suggests that when heat  
penetration in the briquettes is insufficient adequate  
strength will not be generated in the fired product.

#### EXAMPLE 10

25

The effect of residence time in a grate kiln was investigated.

Briquettes made from GH material (d95 = 1mm) and  
30                   nominally 7.5cc were fired in a pilot scale batch grate  
kiln. They were charged green into a kiln that had been  
preheated to either 500 or 1000°C. Firing profiles were  
imposed on the briquettes and the total residence time  
reported. The results are shown in Figure 18.

35

Figure 18 shows that the fired properties improved with increasing residence time, suggesting the

importance of heating the product thoroughly to achieve the final properties required.

The effect of rapid heating was not reduced by a larger bed depth of the grate. This is shown in Figures 19 and 20. The green briquette bed was highly permeable and did not restrict airflow, as often occurs with pellets. The maximum bed depth useable has not been defined, but is likely to be greater than 300mm. This far exceeded that possible for even the best pellet beds in a grate-kiln system.

#### EXAMPLE 11

The effect of the chemistry of briquettes was investigated.

The effect of basicity and temperature on the fired briquette properties made from HG material was determined by firing the briquettes in the muffle furnace at specific temperatures and times. The results are shown in Figure 21.

Results for the chemical analyses of the fired briquettes made at varying basicities produced fired briquettes which varied in grade from 63.81% Fe at a basicity of 1.2 up to 65.93% Fe for a basicity of 0.2, reflecting the level of flux addition.

As can be seen in Figure 21, crush strength increased with both temperature and as basicity increased from 0.2 to 0.8. This effect becomes more significant as the temperature increased across the range studied and it was possible to achieve 300 kgf at 1295°C for 0.6 basicity and at 1280°C for 0.8 basicity.

The explanation for increased basicity levels resulting in increased strengths is related to changes in the bonding mechanism. At low basicity levels, bonding of the particles occurs as a result of recrystallisation of iron oxide and the formation of iron oxide-iron oxide bonds. At increased basicity levels, melt formation occurs at lower temperatures enhancing melting of iron oxide crystals, and slag bonding becomes more significant giving higher strengths for the same temperature.

10

**EXAMPLE 12**

Reduction testing, using whole briquettes and standard reduction test methods JIS 8713/IS07215 was carried out on HG briquettes that were fired at 1300°C for 10 min. The results of reducibility, swell and crush strength after reduction (CSAR) are shown in Figure 22.

The reducibility index (RI) remained relatively stable across the range of basicity levels. The RI varied from 53.8% at a basicity of 0.20 to just over 62.2% at a basicity of 1.00.

The swell index showed some response and varied from 11% at the lowest basicity to 14.8% in the mid-ranges, decreasing to zero at a basicity of 1.20. The crush strength after reduction (CSAR) showed a large response to changes in the basicity level, ranging from 22 kgf at 0.20 basicity to 121 kgf at 1.20 basicity. This change in reduced strength reflects the fired crush strength results and is again related to variation in the bonding phases of the fired briquettes. The low basicity briquettes were predominantly bonded by iron oxide-iron oxide bonds, which degrade during reduction. At increased basicity levels, slag bonding becomes more significant. These bonds are more stable during reduction, accounting for the higher reduced strengths and little or no swell at

a basicity of 1.20. Slag bonding also becomes a more important form of bonding in briquettes made from GH and G where higher  $\text{SiO}_2$  and  $\text{Al}_2\text{O}_3$  levels result in increased flux additions. Such briquettes generally prove stronger after  
5 reduction as the reduction process does not result in the breakdown of non-ferrous bonding phases. High grade ores, such as HC, which require low flux addition rely almost solely on oxide-oxide bonding and hence have lower  
10 strength after reduction values.

10

Many modifications may be made to the embodiments of the present invention described above without departing from the spirit and scope of the invention.

## CLAIMS:

1. A method of producing an iron ore briquette that is suitable for use as a blast furnace or other direct reduction furnace feedstock which includes the steps of:
- 5
- (a) mixing ore and a flux to form an ore/flux mixture;
  - 10 (b) pressing the ore/flux mixture into a green briquette using a low roll pressure; and
  - (c) indurating the green briquette to form a fired briquette.
- 15
2. The method defined in claim 1 wherein the low roll pressure is generated by a roll pressure force that is sufficient to produce briquettes having a green compressive strength of at least 2kgf.
- 20
3. The method defined in claim 2 wherein the green compressive strength is at least 4 kgf.
4. The method defined in claim 2 wherein the green compressive strength is at least 5kgf.
- 25
5. The method defined in claim 2 wherein the green compressive strength is 5-30kgf.
- 30
6. The method defined in claim 2 wherein the green compressive strength is 15-30kgf.
- 35
7. The method defined in any one of the preceding claims wherein the low roll pressure is generated by a roll pressing force of 10-140 kN/cm on the mixture of ore/flux.

8. The method defined in claim 7 wherein the roll pressing force is 10-60kN/cm.
9. The method defined in claim 7 wherein the roll  
5 pressing force is 10-40kN/cm.
10. The method defined in any one of the preceding claims wherein step (a) includes mixing ore having a predetermined particle size distribution of ore particles  
10 and flux particles.
11. The method defined in claim 10 wherein the predetermined particle size distribution of ore particles that is mixed with flux in step (a) can be produced  
15 without grinding ore.
12. The method defined in claim 10 or claim 11 includes crushing and screening ore to form the predetermined particle size distribution that is mixed  
20 with flux in step (a).
13. The method defined in any one of claims 10 to 12 wherein the top size of the predetermined particle size distribution of ore that is mixed with flux in step (a) is  
25 4.0 mm or less.
14. The method defined in claim 13 wherein the top size is 3.5 mm or less.
- 30 15. The method defined in claim 13 wherein the top size is 3.0 mm or less.
16. The method defined in claim 13 wherein the top size is 2.5 mm or less.  
35
17. The method defined in claim 13 wherein the top size is 1.5 mm or less.

18. The method defined in any one of claims 10 to 17 wherein the predetermined particle size distribution of ore that is mixed with flux in step (a) includes less than  
5 50% passing a 45  $\mu\text{m}$  screen.
19. The method defined in claim 18 wherein the  
particle size distribution includes less than 30% passing  
the 45 $\mu\text{m}$  screen.  
10
20. The method defined in claim 18 wherein the  
particle size distribution includes less than 10% passing  
the 45 $\mu\text{m}$  screen.
21. The method defined in any one of the preceding  
claims wherein the ore is a hydrated iron ore.  
15
22. The method defined in claim 21 wherein the  
hydrated ore is a goethite-containing ore.  
20
23. The method defined in any one of the preceding  
claims wherein the flux has a particle size distribution  
that is predominantly less than 100  $\mu\text{m}$ .
24. The method defined in claim 23 wherein the  
particle size distribution of the flux includes more than  
95% passing a 250  $\mu\text{m}$  screen.  
25
25. The method defined in any one of the preceding  
claims wherein the ore/flux mixture produced in step (a)  
is selected so that the basicity of the fired briquette is  
greater than 0.2.  
30
26. The method defined in claim 25 wherein preferably  
the basicity is greater than 0.6.  
35

27. The method defined in any one of the preceding claims wherein there is no binder in the ore/flux mixture.

28. The method defined in any one of the preceding  
5 claims wherein the method includes adjusting the water content of the ore prior to or during mixing step (a) to optimise briquette quality and product yield.

29. The method defined in claim 28 wherein the step  
10 of adjusting the water content of the ore includes adjusting the water content so that the moisture content of the ore/flux mixture is 2-12% by weight of the total weight of the ore/flux mixture.

30. The method defined in claim 28 wherein the step  
15 of adjusting the water content of the ore includes adjusting the water content so that the moisture content of the ore/flux mixture is 2-5% by weight of the total weight of the ore/flux mixture for ores that are dense  
20 hematite ores.

31. The method defined in claim 28 wherein the step  
of adjusting the water content of the ore includes  
adjusting the water content so that the moisture content  
25 of the ore/flux mixture is 4-8% by weight of the total weight of the ore/flux mixture for ores containing up to 50% goethite.

32. The method defined in claim 28 wherein the step  
30 of adjusting the water content of the ore includes adjusting the water content so that the moisture content of the ore/flux mixture is 6-12% by weight of the total weight of the ore/flux mixture for ores that are  
predominantly, ie contain more than 50%, goethite ores.

35

33. The method defined in any one of the preceding claims wherein pressing step (c) produces briquettes that are 10 cc or less in volume.

5 34. The method defined in claim 33 wherein pressing step (c) produces briquettes that are 8.5cc or less in volume.

10 35. The method defined in claim 33 wherein pressing step (b) produces briquettes that are 6.5 cc or less in volume.

15 36. The method defined in any one of the preceding claims wherein indurating step (c) includes heating the briquette to a firing temperature with 40 minutes.

20 37. The method defined in claim 36 wherein indurating step (d) includes heating the briquette to a firing temperature within 35 minutes.

38. The method defined in claim 36 wherein indurating step (d) includes heating the briquette to the firing temperature within 30 minutes.

25 39. The method defined in claim 36 wherein step (c) includes heating the briquette to the firing temperature within 20 minutes.

30 40. The method defined in claim 36 wherein step (c) includes heating the briquette to the firing temperature within 15 minutes.

35 41. The method defined in any one of claims 36 to 40 wherein the firing temperature is at least 1200°C.

42. The method defined in claim 41 wherein the firing temperature is at least 1260°C.

43. The method defined in claim 41 wherein the firing temperature is at least 1320°C.
- 5 44. The method defined in claim 41 wherein the firing temperature is at least 1350°C.
45. The method defined in claim 41 wherein the firing temperature is at least 1380°C.
- 10 46. The method defined in any one of the preceding claims wherein the fired briquette has a crush strength of at least 200kgf.
- 15 47. The method defined in claim 46 wherein the fired briquette has a crush strength of at least 250kgf.

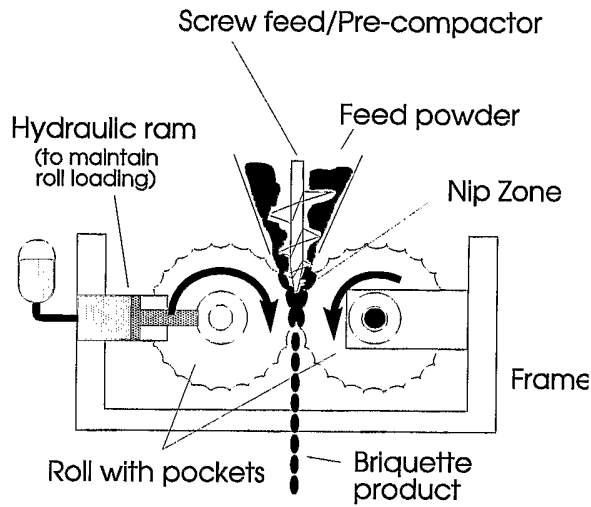

Figure 1. Schematic of the Taiyo K-102 briquetting press

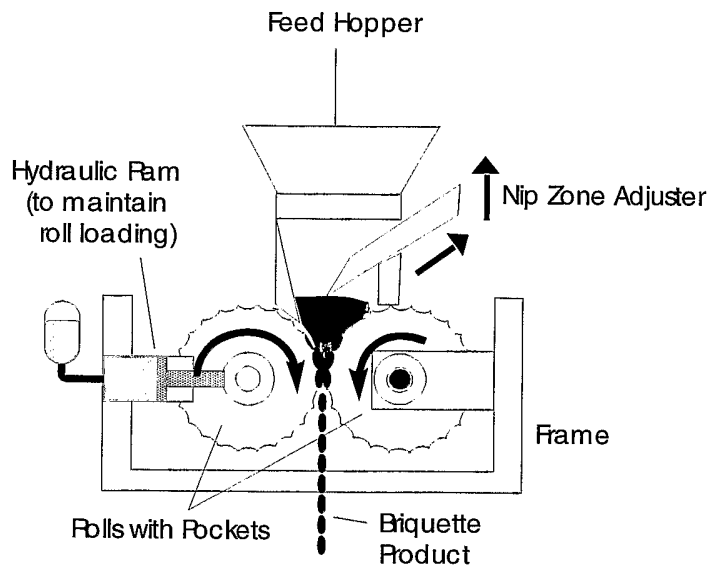

Figure 2. Schematic of the Komarek B400 Briquetting Press

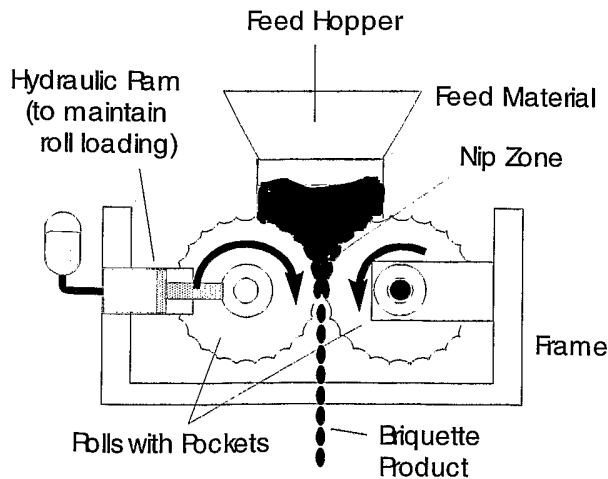

Figure 3. Schematic of the Köppern 52/6.5 Briquetting Press

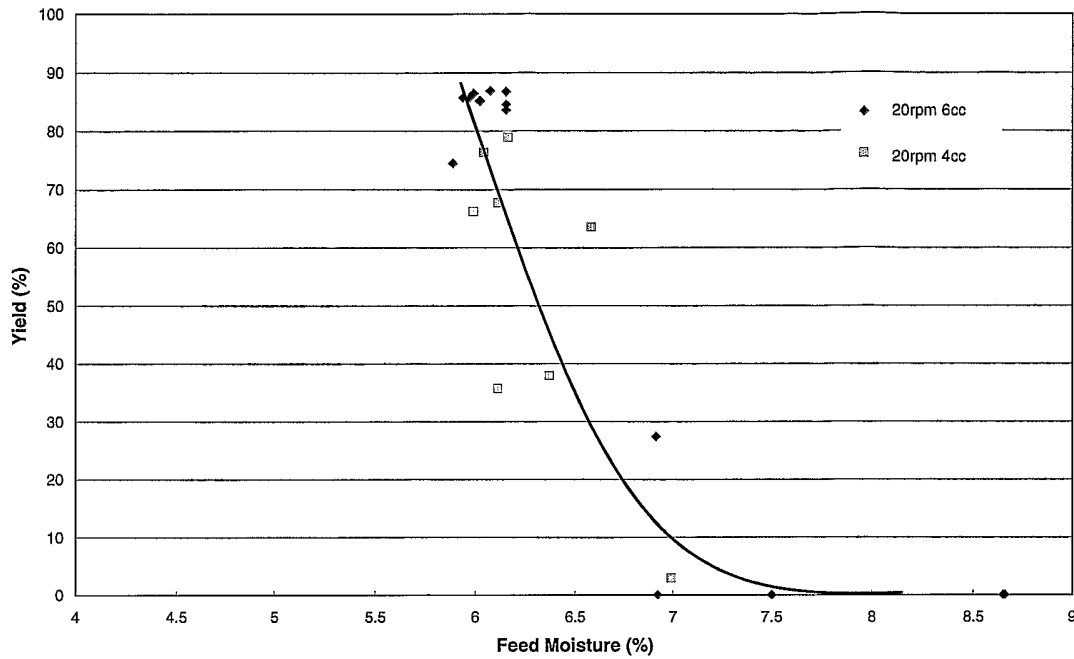

Figure 4. The optimum feed moisture to maximise product yield for HG material on 450 mm rolls with a gravity feed system and varying pocket dimensions

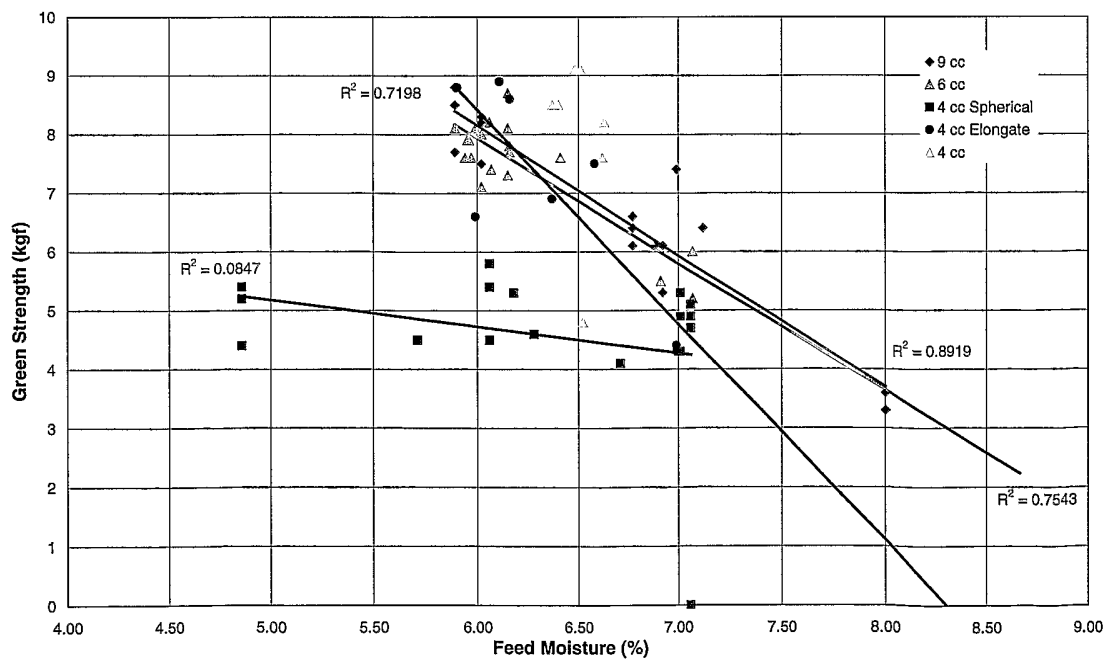

Figure 5. The effect of feed moisture on green strength for HG material using 450 mm rolls, a gravity feed system and a variety of pocket shapes and volumes

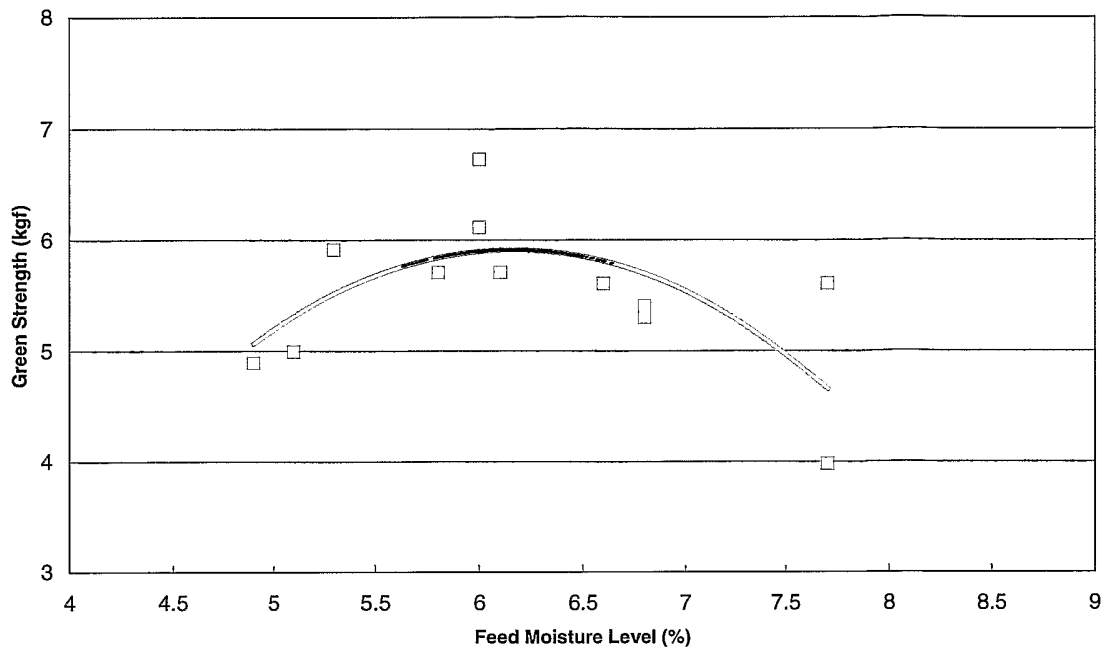

Figure 6. The effect of feed moisture on green strength for HG material using 650 mm rolls, a gravity feed system and nominal 7.5 cc "pillow" form

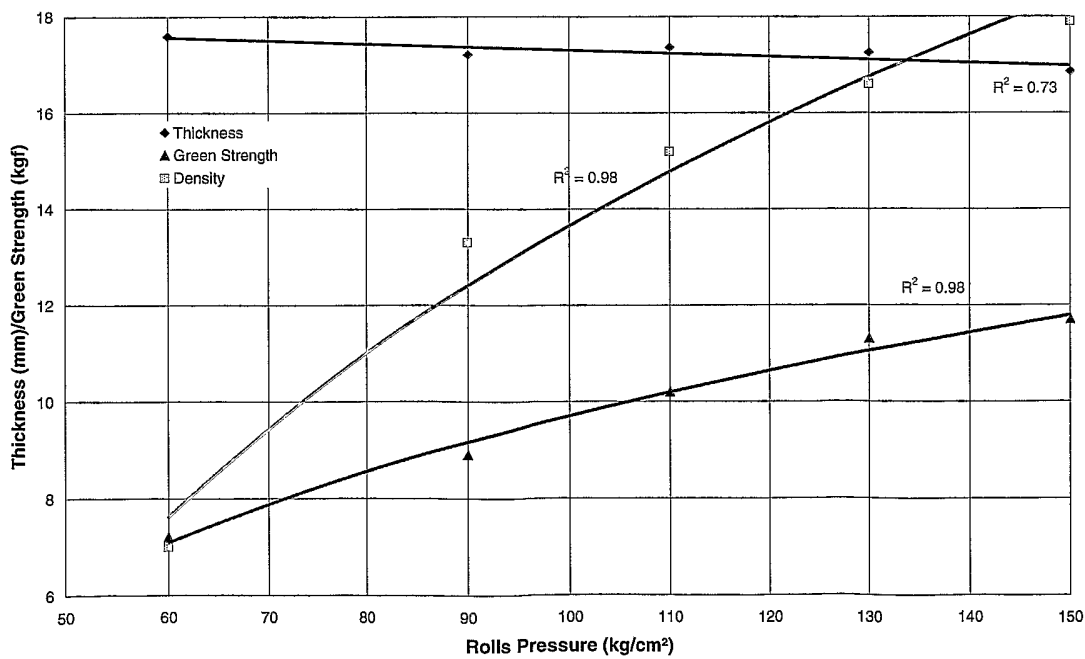

Figure 7. Effect of rolls pressure on green strength using 450 mm rolls and 9 cc pockets - rolls speed = 5 rpm, feed moisture = 6%.

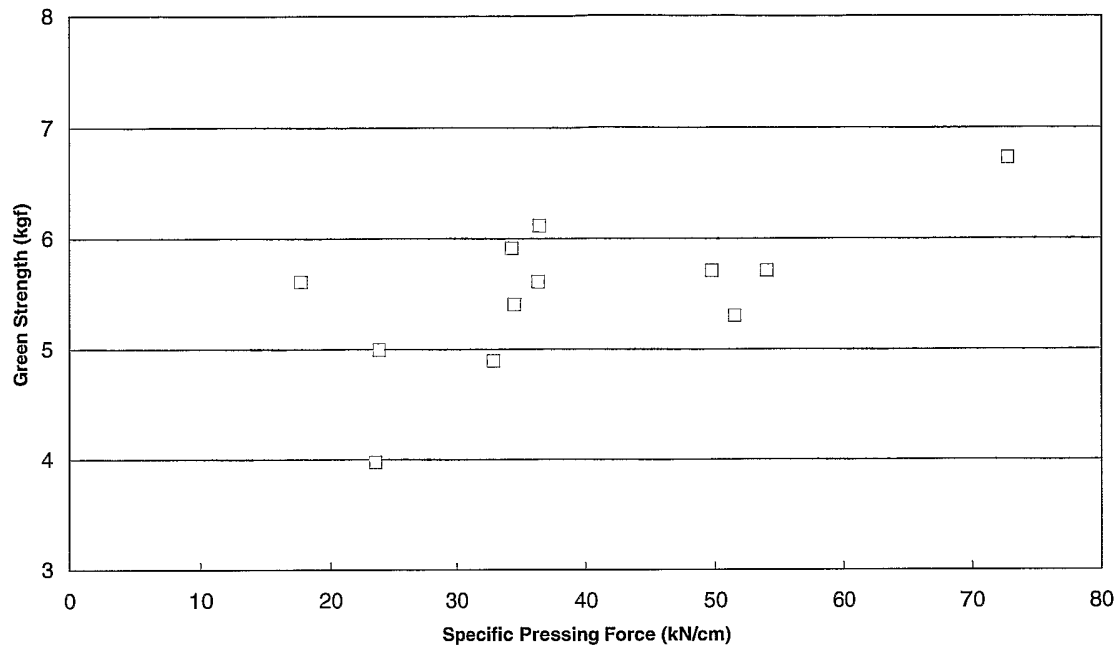

Figure 8. Effect of rolls pressure on green strength using 650 mm rolls, nominal 7.5 cc "pillow" forms and raw material HG

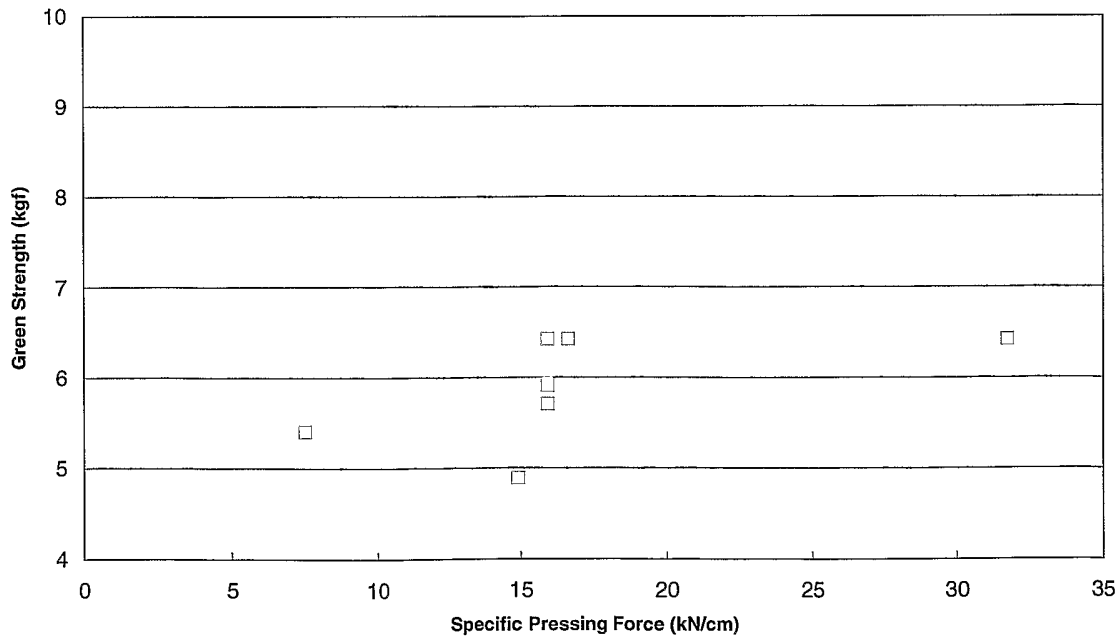

Figure 9. Effect of rolls pressure on green strength using 650 mm rolls, nominal 7.5 cc "pillow" forms and raw material GH

5/11

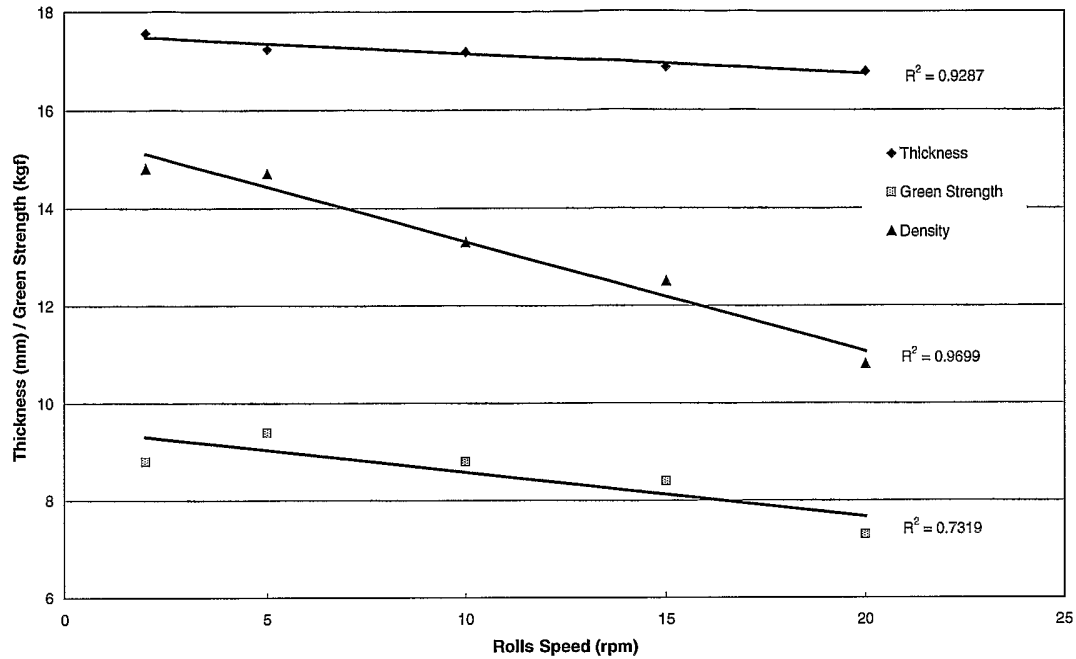

Figure 10. Effect of rolls speed on briquette properties - rolls pressure = 90kg/cm<sup>2</sup>, feed moisture = 6% using 450 mm rolls and nominal 9 cc almond form pockets.

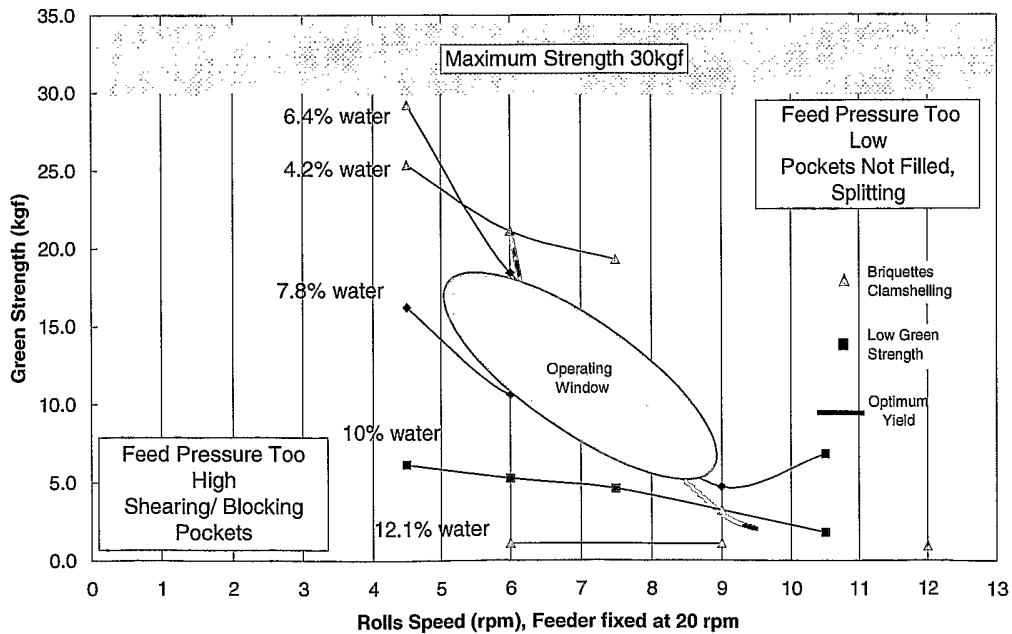

Figure 11. Operating window for briquetting machine with pre-compactor, 250 mm rolls, nominal 4cc almond form pockets and HG material.

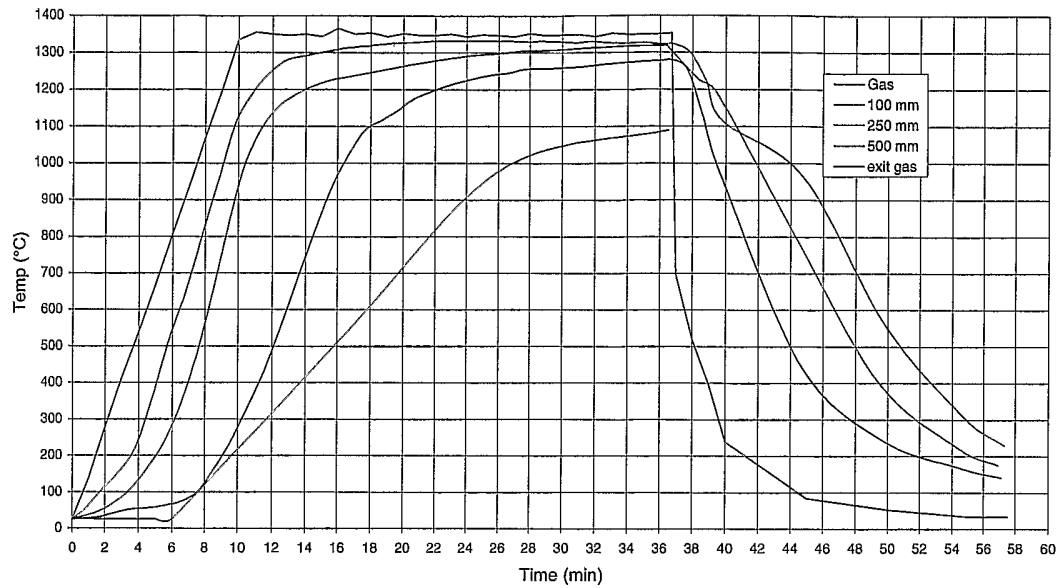

Figure 12. Temperature profile for briquette induration in 500 mm deep bed using a pot grate

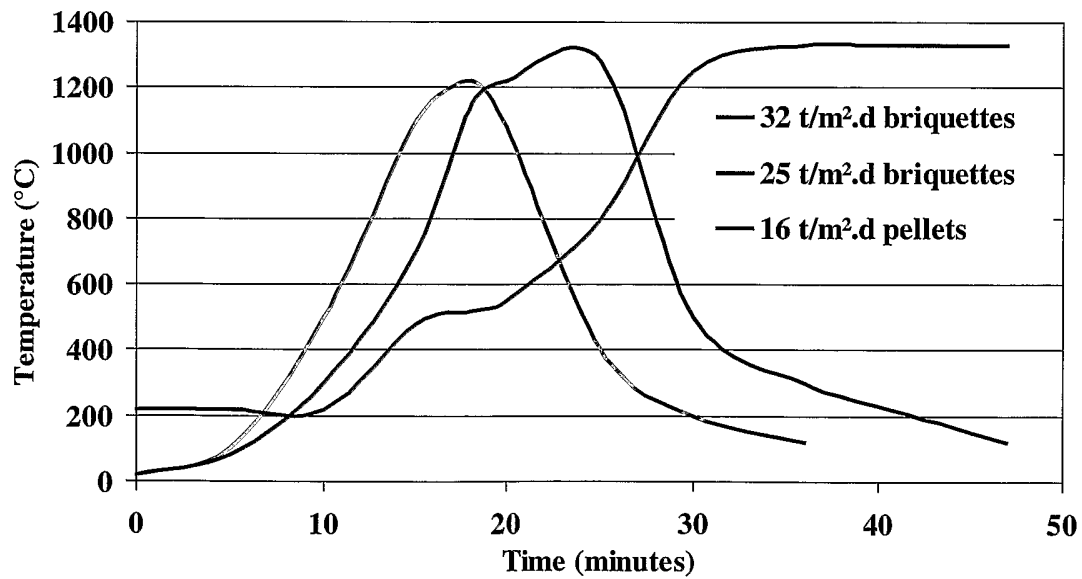

Figure 13. Temperature profile and resultant productivity for nominally 4cc briquettes made from HG material, indurated in a 500mm deep bed using a pot grate, showing the bottom of the bed temperature for the briquette profiles. A typical pellet bed temperature profile for similar material is shown.

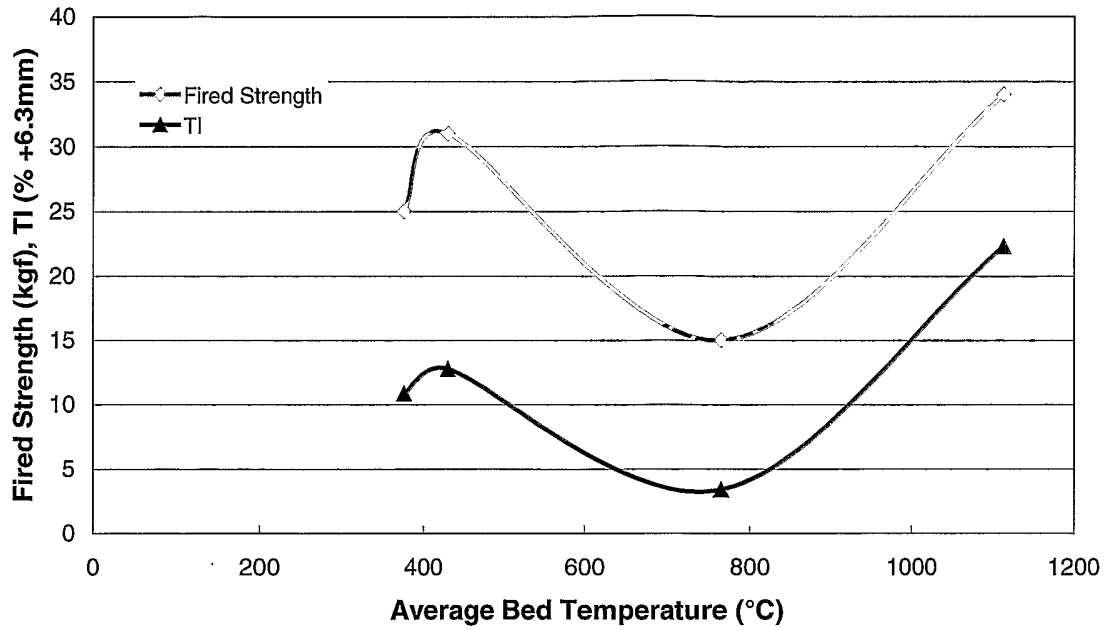

Figure 14. The effect of average bed temperature for GH briquettes (nominal 7.5cc "pillow" form) at the end of the grate cycle used for batch grate - kiln tests

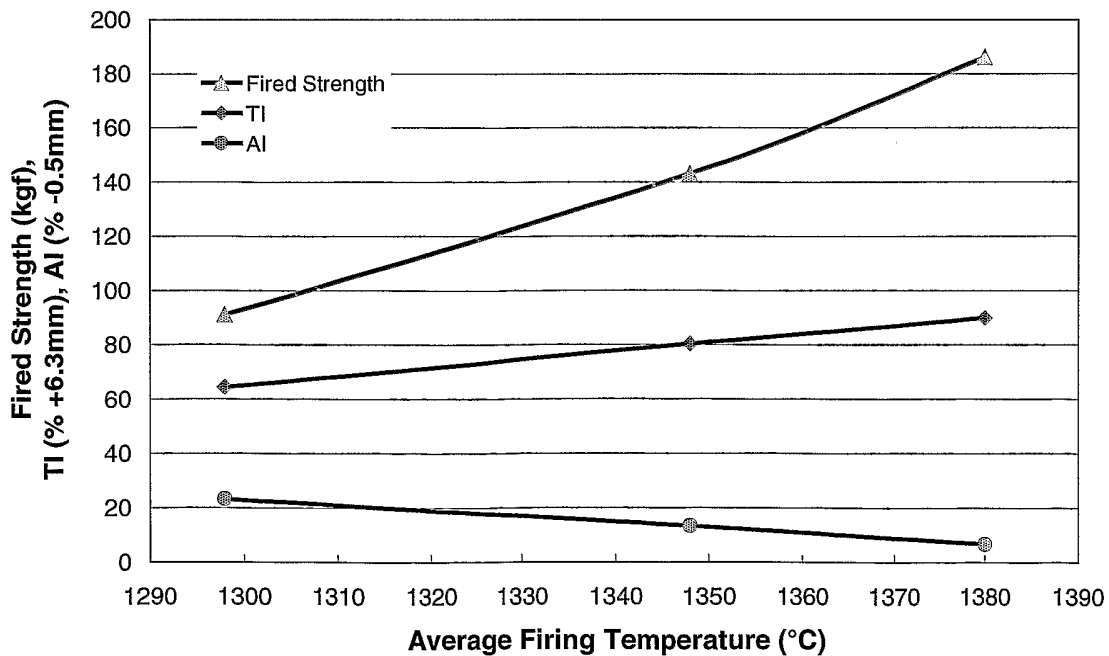

Figure 15. The effect of average firing temperature for GH briquettes (nominally 7.5cc "pillow" form) at the end of the grate - kiln cycle in the batch grate kiln facility

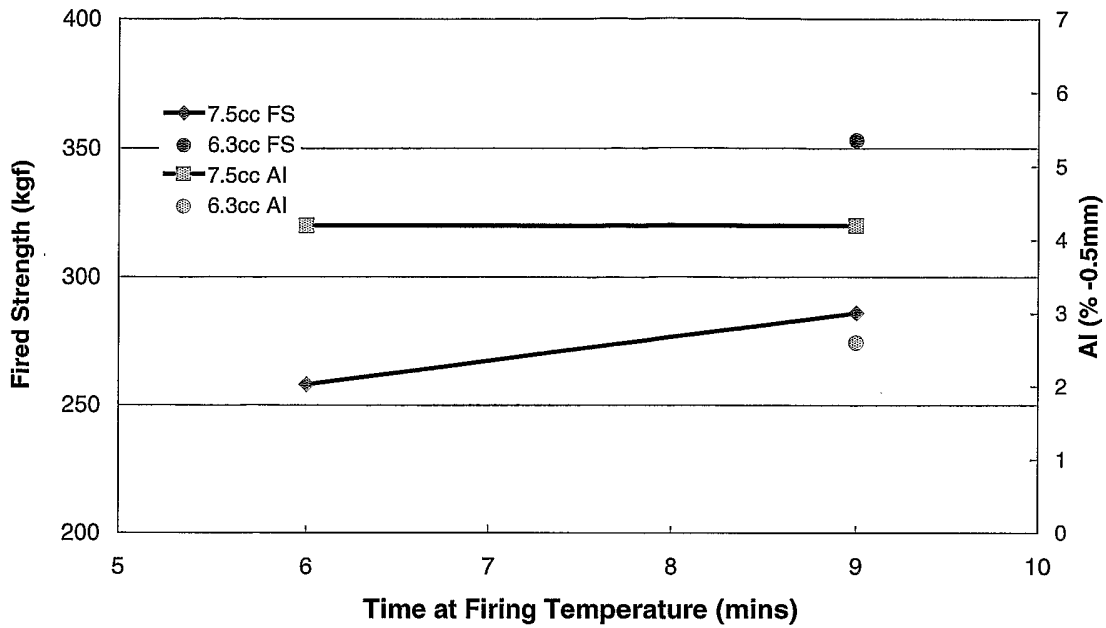

Figure 16. The effect of time at firing temperature (1380°C) on GH briquettes (nominal 7.5cc "pillow" form) in the kiln during a test cycle in the batch grate kiln

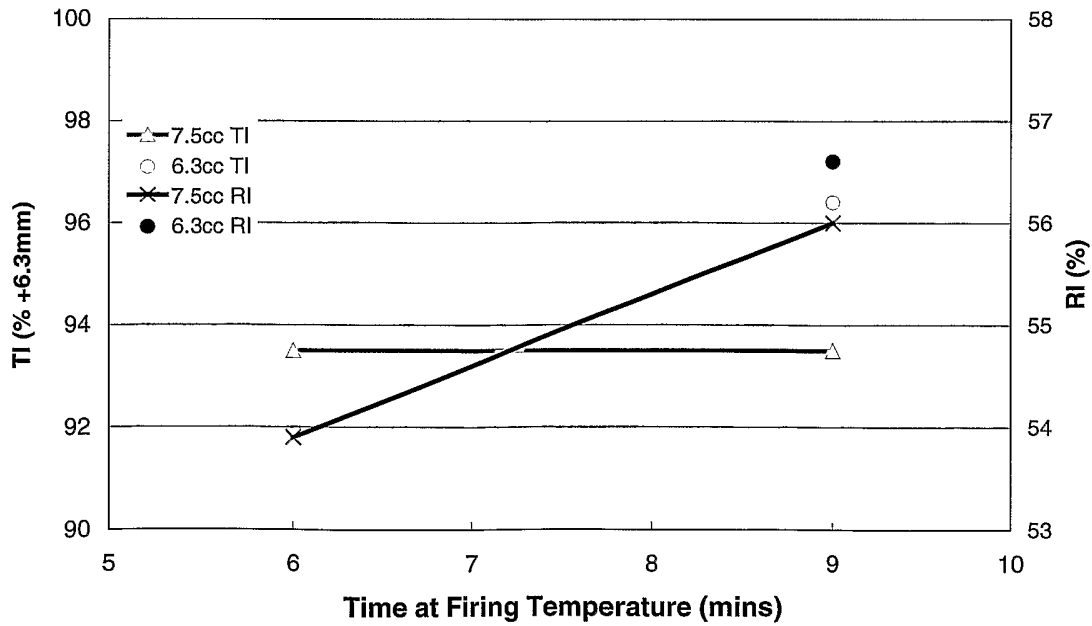

Figure 17. The effect of time at firing temperature (1380°C) on GH briquettes (nominal 7.5cc "pillow" form) in the kiln during a test cycle in the batch grate kiln

9/11

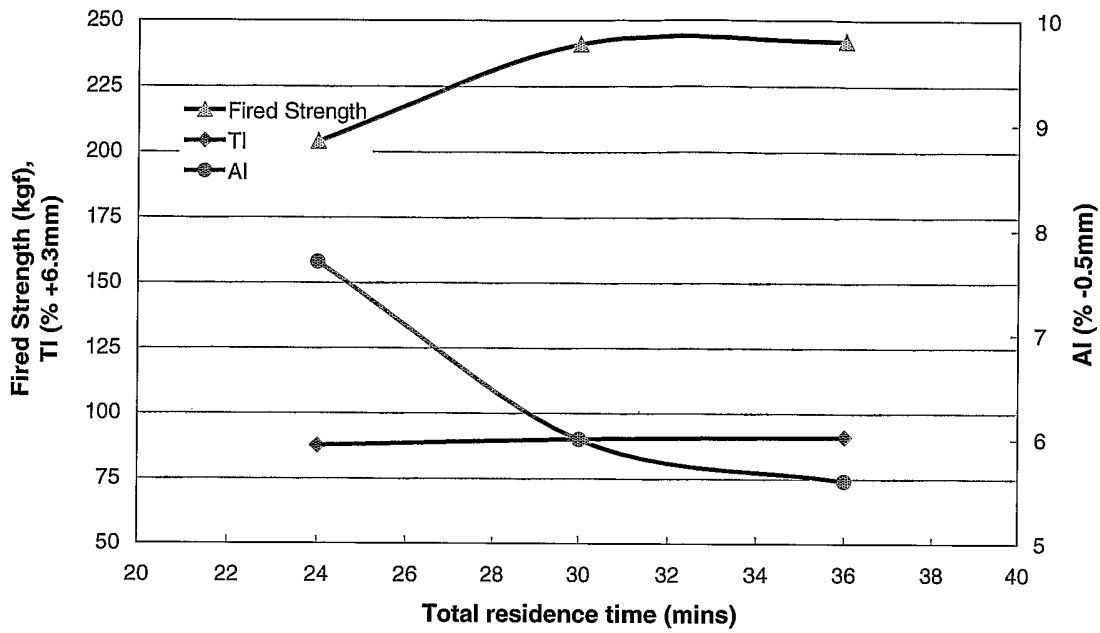

Figure 18. The effect of total residence time for GH briquettes (nominal 7.5cc "pillow" form) in the kiln during a test cycle in the batch kiln

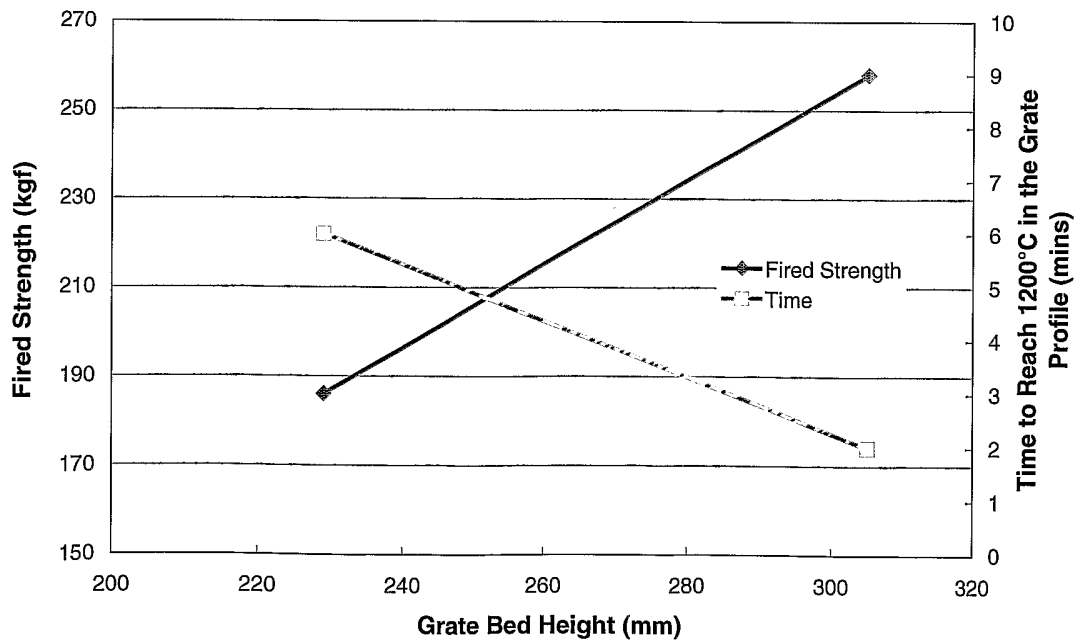

Figure 19. The effect of bed height and grate firing profile for GH briquettes (nominal 7.5cc "pillow" form) after firing using a grate - kiln test cycle in the batch grate kiln

10/11

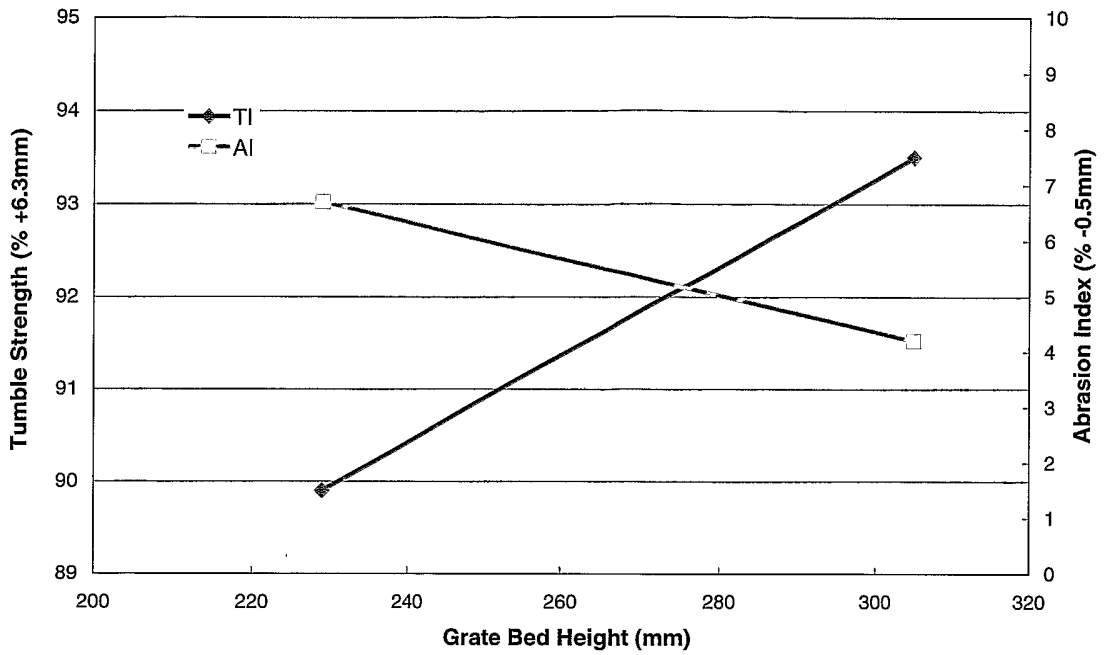

Figure 20. The effect of bed height and grate firing profile for GH briquettes (nominal 7.5cc "pillow" form) after firing using a grate - kiln test cycle in the batch grate kiln

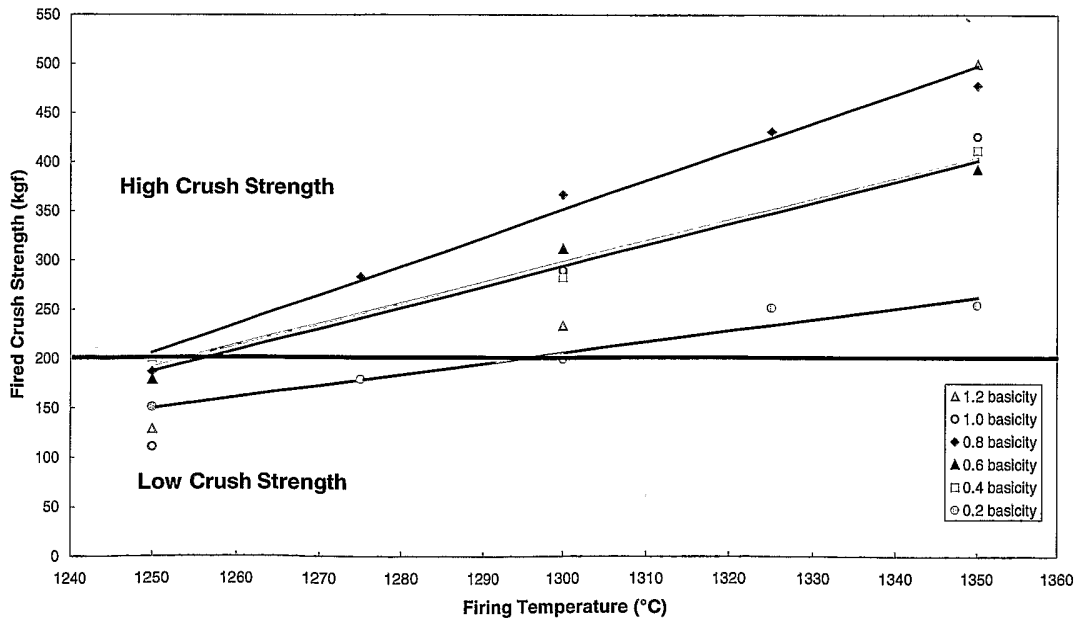

Figure 21. Effect of basicity and firing temperature on fired crush strength for briquettes made with HG material, 250 mm rolls and 4 cc almond form pockets. Induration was conducted in a muffle furnace

11/11

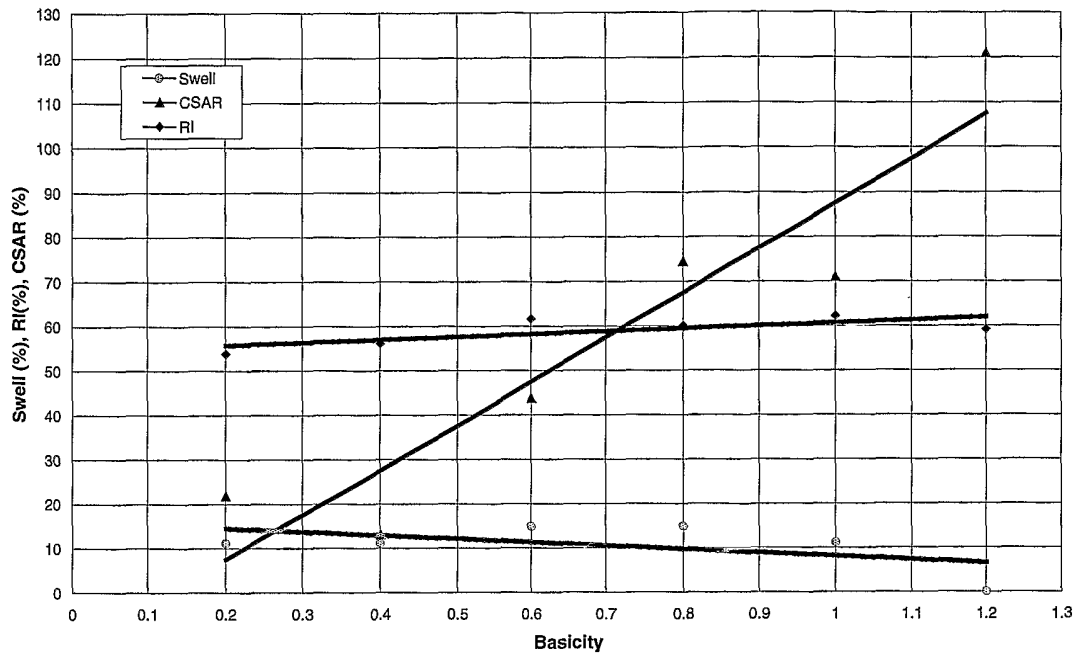

Figure 22. Effect of basicity on briquette reduced properties. Briquettes were made using HG material, 250 mm rolls and 4 cc almond form pockets. Induration was conducted in a muffle furnace



## INTERNATIONAL SEARCH REPORT

International application No.

PCT/AU02/01032

C (Continuation). DOCUMENTS CONSIDERED TO BE RELEVANT		
Category*	Citation of document, with indication, where appropriate, of the relevant passages	Relevant to claim No.
A	EP 207654, B1 ( NIPPON KOKAN KABUSHIKI KAISHA ) 7 January 1987	1-47.
A	EP 271863, B1 (NIPPON KOKAN KABUSHIKI KAISHA ) 12 June 1988	1-47

# INTERNATIONAL SEARCH REPORT

Information on patent family members

International application No.

**PCT/AU02/01032**

This Annex lists the known "A" publication level patent family members relating to the patent documents cited in the above-mentioned international search report. The Australian Patent Office is in no way liable for these particulars which are merely given for the purpose of information.

Patent Document Cited in Search Report	Patent Family Member					
WO 9601333	AU 28751/95	CN 1160422	EP 769074			
WO 9414987	CN 1088990					
US 4919711	AU 18497/88	BR 8803222	CA 1322629			
	CN 1030943	EP 297553	JP 1033041			
	NO 882899	US 4863512	ZA 8804660			
EP 207654	AU 58391/86	BR 8602965	CA 1259493			
	IN 167409	JP 62037325	US 4723995			
EP 271863	AU 82221/87	BR 8706790	CA 1324493			
	CN 87108122	EP 578253	IN 167132			
	JP 63149331	US 4851038	JP 63149332			
	JP 63149333	JP 63149334				
END OF ANNEX						