

(19) World Intellectual Property Organization
International Bureau



(43) International Publication Date
3 April 2008 (03.04.2008)

PCT

(10) International Publication Number
WO 2008/037951 A1

(51) International Patent Classification:
A61F 9/007 (2006.01)

(21) International Application Number:
PCT/GB2007/003408

(22) International Filing Date:
11 September 2007 (11.09.2007)

(25) Filing Language: English

(26) Publication Language: English

(30) Priority Data:
0619305.6 29 September 2006 (29.09.2006) GB

(71) Applicant and

(72) Inventor: PEARSON, Andrew, Robert [GB/GB]; Pebble Cottage, Milestone Avenue, Charvil, Reading RG10 9TN (GB).

(74) Agent: ROBINSON, Simon, Marc; Spires IP, 20 Bridge Street, Oxford OX2 0BA (GB).

(81) Designated States (unless otherwise indicated, for every kind of national protection available): AE, AG, AL, AM, AT, AU, AZ, BA, BB, BG, BH, BR, BW, BY, BZ, CA, CH, CN, CO, CR, CU, CZ, DE, DK, DM, DO, DZ, EC, EE, EG, ES, FI, GB, GD, GE, GH, GM, GT, HN, HR, HU, ID, IL, IN, IS, JP, KE, KG, KM, KN, KP, KR, KZ, LA, LC, LK, LR, LS, LT, LU, LY, MA, MD, ME, MG, MK, MN, MW, MX, MY, MZ, NA, NG, NI, NO, NZ, OM, PG, PH, PL, PT, RO, RS, RU, SC, SD, SE, SG, SK, SL, SM, SV, SY, TJ, TM, TN, TR, TT, TZ, UA, UG, US, UZ, VC, VN, ZA, ZM, ZW.

(84) Designated States (unless otherwise indicated, for every kind of regional protection available): ARIPO (BW, GH, GM, KE, LS, MW, MZ, NA, SD, SL, SZ, TZ, UG, ZM, ZW), Eurasian (AM, AZ, BY, KG, KZ, MD, RU, TJ, TM), European (AT, BE, BG, CH, CY, CZ, DE, DK, EE, ES, FI, FR, GB, GR, HU, IE, IS, IT, LT, LU, LV, MC, MT, NL, PL, PT, RO, SE, SI, SK, TR), OAPI (BF, BJ, CF, CG, CI, CM, GA, GN, GQ, GW, ML, MR, NE, SN, TD, TG).

Published:
— with international search report

(54) Title: IMPROVED TEAR-DUCT DRAIN

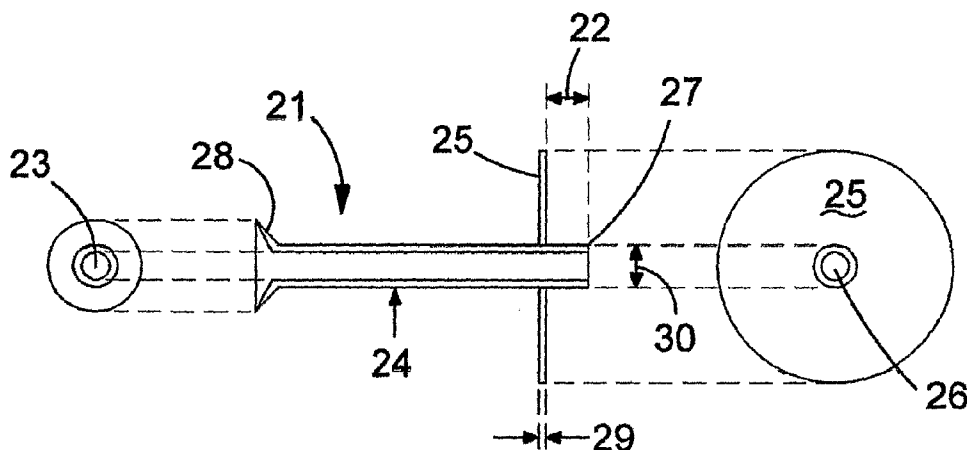

(57) Abstract: A tear-duct drain comprises: (a) a hollow rigid tube, being elongate and having a first flange at one extremity; and (b) a flexible, resilient and collapsible second flange, being bonded to said tube at a predetermined distance away from, and so providing a leading edge at, the opposite extremity of said tube.

WO 2008/037951 A1

IMPROVED TEAR-DUCT DRAINTECHNICAL FIELD

The present invention relates to a medical device that has its main application in
5 corrective tear-duct surgery. The improvements provided by the device greatly help to
overcome the numerous disadvantages of previous approaches in this field.

BACKGROUND ART

In healthy individuals, tear fluid (that is "lacrima" fluid) is normally supplied
10 continuously to their eyes from lachrymal glands, each being located in a lateral and
superior relation to the respective eye. Upper lacrimal ducts feed the fluid from each
gland to a respective conjunctival sac, in which the relevant eyeball is partially encased.
The lacrimal fluid subsequently washes the sclera and other conjunctival components of
the eye, as well as its cornea.

15

Under such healthy conditions, excess lacrimal fluid that cannot be retained by each eye
and conjunctiva tends to be drained (see Figure 1 of the drawings accompanying this
specification) from the inner-canthus (1) (at the corner of the eye) to the nasal passages
(7a,b), in particular to the inferior nasal meatus (7b).

20

After any excess fluid has drained from the inner-canthus (1), it passes through a
network of passages commencing with the puncta, which are seen as small papillae (2,
3) adjacent to the inner-canthus (1). From here, the lacrimal fluid is subsequently

collected in the lacrimal sac (6), which is connected to the puncta via a number of canaliculi (4, 5). The lacrimal fluid is thereafter drained through the nasolacrimal duct (8) into the interior meatus (7b) of the nose.

5 Sometimes, if an unwanted closure of the passageways of the system occurs, for example by way of a blockage of any one of its sub-components, excess lacrimal fluid can no longer be disposed of in the usual way. Such a blockage can result from, inter alia, congenital anomalies, accidents, inflammation, advancing age, and so forth, and tends to cause the eye to continuously brim over with tears, with concomitant
10 discomfort to the individual.

More seriously, if the blocked tears stagnate, they can become infected, which can then lead to inflammatory irritation of the mucous membranes of the affected passage. In turn this can result in proliferation of local epithelium, as well as hyperaemia, and even
15 a purulent exudation into the conjunctiva. Infection caused in this way can ultimately lead to scarring over of the canaliculi (4,5).

In severe cases, the resultant permanent closure can require a corrective surgical procedure known as a dacryocystorhinostomy (DCR). In some of these cases, only the
20 defective portion of the lacrimal drainage system needs to be reconstructed. Thus, if the sole blockage occurs in, for example, the nasolacrimal duct, the latter can be removed, and the remaining lacrimal sac cavity can then be joined directly with the mucosa of the nasal fossa. This is typically achieved by removing tissue, including the intervening

segment of nasal bone and periosteum, so that the drainage of tear liquid into the nose can be more or less restored.

In many other cases, however, removal of the entire lacrimal drainage system may be
5 necessary, the insertion of a replacement mechanical device (for example a tube) then being required. Such operations have to date seldom been entirely successful, because at least the following two particular difficulties have typically been experienced.

10 Firstly, as the nasal bone heals around the lower end portion of the inserted replacement tube, the latter is gradually rejected from the bone and flesh of the patient. And secondly, the patient's flesh also tends to heal over the external end of the replacement tube at the inner-canthus (1), which therefore requires appropriate surgical reopening from time to time.

15 Conventionally, the replacement tube utilised in tear-duct surgery has been a small tube constructed of Pyrex™ glass, stiff plastic or some other relatively rigid material. However, usually it is Pyrex™-type glass that has been preferred, since this can neither be destroyed, nor corroded or otherwise affected by a patient's bodily fluids.

20 These tubes of Pyrex™ glass are generally known by surgeons as "Lester Jones" tubes, being named after their designer, Mr Lester T Jones, and are sometimes simply referred to as "Jones" tubes. Very similar devices go by the alternative trade names "Callaghan Cox", "Gladstone Putterman", "Baylis", and "Naugle" tubes. These replacement tubes

have a typical length of the order of about 18mm and, as such, are inserted into the inner corner of the eye, and then down the surgically created passage, so as to allow the drainage of the excess lacrimal fluid internally into the nose.

5 Despite their rigidity, the main flaw of these replacement Jones-type tubes is that, as described above, they usually tend to be worked out of their in situ position by the action of the patients' own bone and flesh. They are therefore at risk of being completely lost either by descending into the nasal passage or by ascending into the eye. In either eventuality, the function of these replacement tubes is of course utterly
10 negated, consequently necessitating the inconvenience and cost of one, or more, further corrective operations.

In addition, double-flanged Jones-type tubes have also been previously made available. These have two opposing flanges at either end of a hollow shank, with the aim of
15 attempting to prevent their rejection. However, these tubes tend not to be particularly effective either since, in practice, they have at least the following extra disadvantages:

a) The relatively larger diameter of their additional leading (internal) flange of rigid glass, as compared to that of their hollow shank, means that these tubes are
20 relatively very difficult to place in situ. This is because the surgically created passage is more difficult to open and traverse by a large leading flange.

b) Further, a large leading flange requires either a correspondingly larger surgically passage to be created before the tube's insertion, or if the flange is pushed through an otherwise smaller passage, damage to the tissue surrounding the passage is likely to create a larger diameter through the passage. Hence, when the tube has been placed in situ, its shank will be inherently less stable.

c) The diameter of the rigid internal flange is nevertheless still relatively small compared to that of the passage after its insertion and so little barrier to the extrusion of the in situ tube is thereby provided.

d) This leading flange is furthermore positioned at a relatively sub-optimal site along the shank, being right at its internal tip and, therefore, after insertion the orifice at this tip is prone to blockage by the normal growth of the nasal mucosa that closely surrounds it.

Other prior devices include those as follows:

FR-A-2, 813, 522 (see Figures 2 and 3 accompanying the present specification) discloses the use of a tubular lacrimal drain (11, 12) having one or more parts, one of which is an internal fixing unit. This allows anchoring of the drain (11,12), typically by providing a screw-threaded attachment means (10, 12a).

CN-A-1, 650, 824 also provides an artificial tear duct, in this case being in the form of a spiral spring-like structure, typically used as a temporary stent to allow scar tissue to become stable before the spring is softened and thereafter pulled out as an unravelled metal wire.

5

US-B-5, 062, 831 (see Figures 4A-C accompanying this present specification) discloses the use of a solid tubing (16), having no lumen, for temporarily removing excess lacrimal fluid by capillary action. A conventional DCR is performed, by removing adjacent bone so that the remaining sac communicates with the internal nasal meatus
10 (7). A catheter (13), with enlarged portions (15) at either end of an elongate shank portion (14), is used simply as a temporary stent to prevent scarring over of the newly opened hole between the sac and the nose.

This procedure, whilst being a suitable treatment for nasolacrimal duct (8) obstruction,
15 cannot assist canalicular (4, 5) obstruction surgery. This is, firstly, because no external opening on the corner of the patient's eye is made. And, secondly, even if it were to be made, the internal opening created by the DCR is kept overly large by the similarly large diameter of the catheter's shank portion (14), which in any case creates a degree of instability. Understandably, the use of such a catheter (13) is taught purely as being a
20 temporary measure.

JP-A-2004-230, 012 (see presently accompanying Figures 5A-C) discloses a tear duct stent (17) that has enlarged portions (or collars) (18; 19a, 19b) at either end of a tube

(20). Hence, this stent is similar in shape to the above-described double-flanged Jones tube, but because this stent is formed of a soft material, the length of its tube can be adjusted as required by cutting it with scissors. Further, having been placed in situ, one or more of its collars may subsequently be cut away to allow the remainder of the stent
5 to be pulled and so removed.

Because of its enlarged ends, insertion of the device can again be problematic, as with the double-flanged Jones-type tubes. Also, the creation of a tissue passage lumen of relatively larger diameter (21) than that of their tube itself may occur, so that in situ
10 instability can once again be a problem.

Moreover, temporary removal of these stents does not appear to be possible, and is not taught in JP-A-2004-230, 012. Indeed, its teaching appears to suggest that the device (17) can be constructed in situ, for example by bonding either (or both) collars (18; 19a,
15 19b) to an already inserted tube (20). Even this would seem to be manually difficult and, potentially, impractical.

The present invention aims to provide an improved device for correcting tear-duct obstructions and, in particular, for the correction of canalicular obstructions. The latter
20 have previously tended to be even less successfully treated than blockages of other tear-duct system parts.

DISCLOSURE OF INVENTION

Thus, according to one aspect, the present invention provides a tear-duct drain comprising: (a) a hollow rigid tube, being elongate and having a first flange at one extremity; and (b) a flexible, resilient and collapsible second flange, being bonded to
5 said tube at a predetermined distance away from, and so providing a leading edge at, the opposite extremity of said tube.

The device of the present invention has the advantages that it can be more accurately placed in situ and with greater ease than previous devices, as well as being able to be
10 left more stably in situ afterwards. This befits the relatively more permanent correction that it can provide, if such permanency is required.

Potentially permanent devices of this type also need to be easily removeable, at least temporarily, so that they can be cleansed along with the patient's consequently vacated
15 tissue passageway. This helps to avoid, for example, microbial contamination, so that tissue damage resulting from inflammation is less likely to occur. If left unchecked, however, such damage would tend to increase the likelihood of rejection of the device from the patient.

20 The elongated tube of each of these improved devices may be made of any suitably inert material that promotes a high level of biocompatibility with patient tissue, as well as the preferred ease of cleaning the device as a whole upon its temporary withdrawal.

Whilst the tube of the present device has a first enlarged external portion at one end that is designed to act as an anchor at the corner of the patient's eye, it also has a collapsible second flange that is preferably positioned towards the opposite end of the tube. Because of its resilience and, typically, relatively large diameter, this second flange
5 tends to prevent the device from slipping. This is because it helps to secure the tube in its in situ position, and so stabilise it against any forces (for example during sneezing of the nose or blinking of the eye) that it might experience thereafter. This is effected by the opening-up of the flexible flange inside the patient's nose and its subsequent positioning against the nasal mucosa around the internal opening of the tissue
10 passageway.

Preferably, the flexible material of which the collapsible second flange is constructed has a relatively much smaller dimension of thinness compared to that of the diameter of the elongate tube. As such, when the device is being inserted, or being temporarily
15 withdrawn, this second flange is consequently encouraged by the surrounding tissue of the passageway to flex. Thus, it can lie flush against the body of the tube, and to the appropriate side of the site of its bonding to the tube, depending upon the relative direction of movement of the tube.

20 This helps to reduce as much as possible any increase in effective total diameter that is presented by the drain, in terms of the combined cross-section of both its tube and its flush second flange, as it is passed through the patient's tissue. In particular, the tube

may be indented on either side of the site of bonding to provide recesses (in the tube's surface) that can accommodate the second flange when flexed.

During the device's insertion, and any temporary withdrawal, the risk of either damage
5 to the device, or traumatisation of the patient's tissue, can thus be minimised. Removal
of the device, as frequently as is needed, is facilitated therefore allowing it to be
cleansed according to each patient's needs. No matter how often such removal is
performed, damage to tissue is minimised, which in turn helps to maximise the long-
term stability of the device when it is left in situ.

10

Further advantageous and optional features are mentioned in the accompanying
subsidiary claims.

The present invention will now be described, in a non-limiting way, by the following
15 preferred examples with reference to, and as illustrated in, the accompanying figures, in
which:

BRIEF DESCRIPTION OF DRAWINGS

Figure 1 schematically illustrates the functional anatomy of a normal and healthy tear-
20 duct system;

Figures 2-5 depict known devices attempting, as described above, to correct various
obstructions of unhealthy tear-duct passages;

Figures 6A-D show an improved device according to one embodiment of the present invention;

5 Figures 7A-D illustrate an improved device according to a further embodiment of the present invention;

Figures 8A-B show an enlarged view of one embodiment of the device of the present invention, in which the site of bonding of the second flange to the tube is schematically
10 highlighted; and,

Figures 9A-E depict some variations of possible shapes for the second flange of the device of the present invention.

15 BEST MODE FOR CARRYING OUT THE INVENTION

The tear-duct drain (21) shown in Figure 6A has a first flange (28) at the external (that is, inner-canthal) opening (23) of its tube (24). A second flange (25) is also provided and is positioned close to – but not at – the internal (that is, nasal) opening (26) of the leading edge (27) of the tube (24).

20

Preferably, the tube (24) and first flange (28) are composed of a rigid material, for example a glass or a plastics material. Glass is generally a preferred material, since it has excellent capillary characteristics and is very biocompatible.

The relative dimensions, and relative resilience, of the second flange (25) are predetermined to allow the tube (24), when in situ, to be stable to any potentially destabilising forces that might otherwise cause either its movement inwards into the nose or outwards towards the eye. Patients are therefore provided with a significant safety benefit to their eyes. Complete loss of the device (21) is also reduced.

The relative resilience of the second flange (25) can be defined in terms of the degree of the relative shear forces involved. That is, for example, the maximum shear force that the flange (25) can withstand before it collapses; and, the respective minimum that it can overcome before it bounces back into shape.

The flexibility of the second flange (25) also ensures that it can collapse in both directions. That is, both: (i) towards the external end (28) of the tube (24) [a “first flush position”]; and, (ii) towards the leading edge (27) of the tube (24) [a “second flush position”]. The position adopted depends upon the direction in which the tube is being urged by the surgeon.

The second flange (25) can thus adopt the first flush position during the tube’s insertion (that is, in direction I, as shown in Figure 6B). Once the internal end of the tube (24) reaches the space just beyond the entrance to the inside of the nose, the resilience of the second flange (25) enables it to spring open. Thus, somewhat in the manner of an umbrella, it can change its configuration from being folded into being in an open

position. This springing open can if necessary be facilitated by the surgeon, for example by applying a degree of manual pressure against the elasticity of the tissue area surrounding the nasal (inner) orifice of the lumen of the passageway, so as to aid release of folded flange into nasal meatus (7).

5

Subsequent fixing of the tube (24) into its secured, in situ position is encouraged by the resilient nature of the opened internal second flange (25) and its typically substantially larger diameter, as compared to that of the inner orifice. This is further encouraged when the device (21) is slightly withdrawn back towards the eye (that is, in the opposite
10 direction to direction I in Figure 6B), so that the second flange (25) abuts against the tissue surrounding the inner orifice.

Moreover, maintenance of this secure fixing is also encouraged by minimising any potential increase in the diameter of the passageway, that might otherwise be caused by
15 trauma to the patient's tissues both during initial placement and during temporary withdrawal of the device (in direction II as shown in Figure 6D). This is achieved by ensuring that the thickness (29) of the flange (25) is relatively small compared to the cross-sectional diameter (30) of the tube (24). In other words, by minimising the total cross-sectional diameter of the device (21) with the second flange (25) collapsed in its
20 first flush position.

As shown in Figures 7A-D, such minimisation can optionally be achieved by adapting the tube's shape to include indentations on either side of the bonding site of the second

flange, which can therefore adopt the flush positions by collapsing into and thus being held in the recesses (for example, 31) so created.

The collapsible flange is typically bonded to the inert material of the tube (24) by a suitable adhesive. For example, any glue that can bond potential collapsible flange (25) material, such as silicone, to the material of the tube (24), for example glass, can be used. The chosen glue should also preferably be able to withstand high temperatures for autoclaving, as well as being generally tissue biocompatible.

The shape of the flange (25) at its site of bonding to the tube may be splayed to allow greater strength. Thus, for example, as shown in Figure 8 (for one non-limiting embodiment) the splaying (34, 35, 36) may advantageously allow the flange (25) to have a greater surface area that can be adhered to the tube (24).

As mentioned, the bonded second flange (25) can be made of any appropriately flexible material that retains its memory after deformation, such as, for example a silicone or a rubber, or indeed alternatively any suitable plastics material.

The exact shape of the second flange (25) can be chosen to suit the needs of each specific patient and so it need not necessarily be circular (as shown in Figure 6A) in cross-section.

Thus, further non-limiting examples of the many different types that can be appropriately utilised are shown in Figures 9A-E. In particular, if the second flange (25) comprises a plurality of arms radiating from the central lumen (26), it is preferable that an odd number of arms are incorporated. This allows the arms to fold into a more compact arrangement as the flange (25) collapses, thus minimising the cross-sectional diameter of the device (21) as it is inserted into place or temporarily withdrawn for cleaning. Additionally, the outer circumferential profile of the second flange (25) is preferably as uniformly smooth as possible, for example any arms should preferably have rounded extremities.

10

Importantly, the second flange (25) is pre-bonded at a predetermined set distance (22) from the internal end (27) of the glass tube (24), and so the clinician need not actually bond the second flange (25) to the tube (24) at any stage. Further, the glass tubes are also typically manufactured to predetermined lengths, so that, the length required to match each patient's anatomy can be chosen by the surgeon before the corrective procedure is commenced.

15

As noted above, many of the previously known devices appear to have been designed for insertion solely as a temporary measure after surgery and, as such, they are used simply to keep an artificially created passageway open for long enough for the patient's surrounding tissues to heal. Often known as "stents", these devices are removed once the appropriate number of weeks or months, after the surgery, have elapsed. In addition,

20

almost all are usually inserted through at least a remaining part of the patient's own lacrimal apparatus that has retained some workable function.

By contrast, the improvements provided by the device (21) of the present invention
5 allow it to be inserted, if necessary, as a relatively permanent system, often as an independent bypass of a patient's natural tear-duct system. The chosen parameters of the device (21) and particularly those of its second flange (25), greatly enhance its ability to efficiently provide this permanent type of treatment, by avoiding counter-productive complications (such as inflammation of the nearby tissues, and so forth) that,
10 as mentioned above, might otherwise arise.

In use, as also indicated above, the present device (21) is particularly suited to correction of canalicular obstructions. Once the clinician has surgically created the appropriate bypass tissue passage into the nasal meatus (7), the device (21) can easily be
15 placed into the correct in situ position (as shown in Figure 6C). By making use of the slight elasticity of the intervening tissue, this can be achieved by inserting it inwardly into the passage (see Figure 6B) until the leading edge (27) of the tube is sufficiently inside the nasal meatus (7). This allows the internal second flange (25) to have already flexibly opened out due to its inherent resilience. The device (21) can then be
20 withdrawn slightly until the opened second flange (25) abuts the nasal mucosa surrounding the internal orifice of the bypass passage. The positioning of the internal second flange (25), and thus the in situ placement of the device (21) as a whole, can therefore be accurately controlled by the clinician.

The bonding of the second flange (25) to the tube (24) at a predetermined distance from the internal end (27) of the tube, ensures that a section (22) of the tube is proud of the second flange (25). Being proud, its obstruction (for example by the formation of scar tissue from the nasal mucosa) is much less likely when it is in situ, so helping to
5 promote a more continuous drainage of the excess lacrimal fluid.

Devices according to the present invention may, of course, differ in their absolute dimensions from case to case, with these being specifically chosen so as to maximise
10 the above-described advantages for each individual patient.

Purely as a way of illustrating this specificity in a non-limiting manner, in one embodiment of the present invention, the outer diameter of the first, rigid flange (28) might be chosen to be between about 3 to 4mm, whilst that of the tube (24) would then
15 suitably be about 2-2.5mm. In such a case, the diameter of the second flange (25) would typically be of the order of 7.5mm or less, and preferably about 5mm. Its thickness (29) would consequently be of the order of 1mm or less, and the tube's proud section (22) would also generally have a chosen length of about 1mm.

20 The dimensions of any recesses (31) as mentioned above – for example see Figure 7 - can also be varied to accommodate the associated dimensions chosen for the second flange (25). Alternatively, portion of the tube (24) adjacent to the edges of the flange (25) can be raised slightly to provide support.

In conclusion, the advantages of the improved device according to the present invention, as compared to known devices, include the following.

- 5 It is simpler to insert, especially compared to devices having an enlarged flange as their leading edge. The large internal flange provides the much greater stability in situ that is required for a permanent device. Moreover, because its leading edge also provides in situ a set length of tube that is proud inside the nasal meatus, obstruction of the internal orifice of its lumen is much less likely.

10

It can also be readily removed on a temporary basis to allow its regular cleaning and, following its reinsertion, any risk of it falling out thereafter is minimised.

- 15 In order to remain securely in situ, the device does not depend upon gravity, by having the relatively large weight flanges that are used in some known devices.

The device also does not rely upon its tube having to be cut to size or glued during its insertion, or its flanges being cut off to allow its withdrawal.

20

CLAIMS:

1. A tear-duct drain comprising: (a) a hollow rigid tube, being elongate and having a first flange at one extremity; and (b) a flexible, resilient and collapsible second flange,
5 being bonded to said tube at a predetermined distance away from, and so providing a leading edge at, the opposite extremity of said tube.
2. A tear-duct drain as claimed in claim 1, wherein said second flange has a relatively smaller predetermined thickness, in a direction parallel to that of the elongation
10 of said tube, compared to the cross-sectional diameter of said tube; whereby the ratio is minimised of: (i) the cross-sectional diameter of the total of both the conduit together with the second flange, when flush against said conduit, to (ii) the cross-sectional diameter of said conduit alone.
- 15 3. A tear-duct drain as claimed in either claim 1 or claim 2, wherein said predetermined distance, away from said opposite extremity of the tube, has a relatively smaller dimension than that of the total length of said tube.
4. A tear-duct drain as claimed in any preceding claim, wherein said second flange
20 has a relatively greater diameter than that of said first flange.
5. A tear-duct drain as claimed in any preceding claim, said drain being composed of biologically inert material.

6. A tear-duct drain as claimed in any preceding claim, wherein its tube and first flange are composed of a rigid material, for example a glass or a plastics material.
- 5 7. A tear-duct drain as claimed in any preceding claim, wherein the leading edge of said tube is squared or chamfered.
8. A tear-duct drain as claimed in any preceding claim, wherein said second flange has a predetermined resilience allowing it a flexibility to deform during placement and
10 removal, yet allowing it an in situ rigidity to resist such deformation.
9. A tear-duct drain as claimed in any preceding claim, wherein said second flange is composed of a biocompatible material, such as a silicone or a soft plastic material.
- 15 10. A tear-duct drain as claimed in any preceding claim, wherein the cross-sectional shape of the second flange comprises a plurality of arms.
11. A tear-duct drain as claimed in claim 10, wherein said plurality of arms is composed of an odd number of arms, optionally each arm being interconnected by a
20 predetermined thickness of material.
12. A tear-duct drain substantially as hereinbefore described with reference to, and/or as illustrated by, Figures 6-9 of the accompanying drawings.

1/6

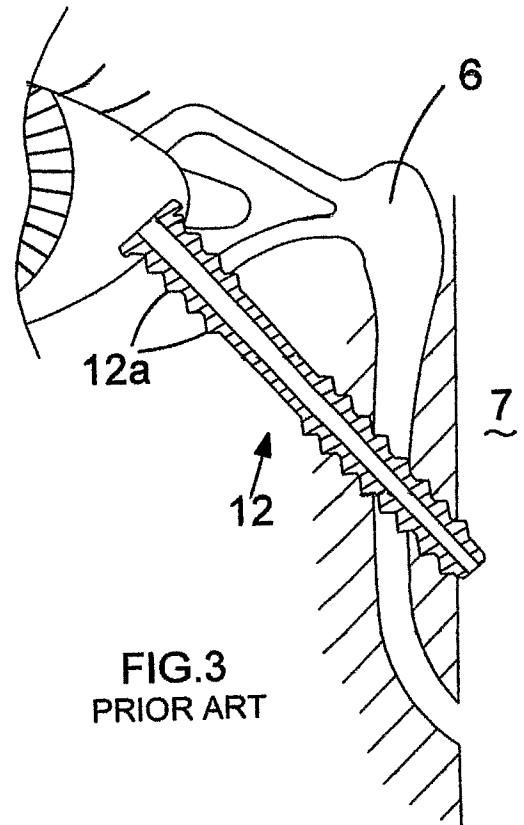
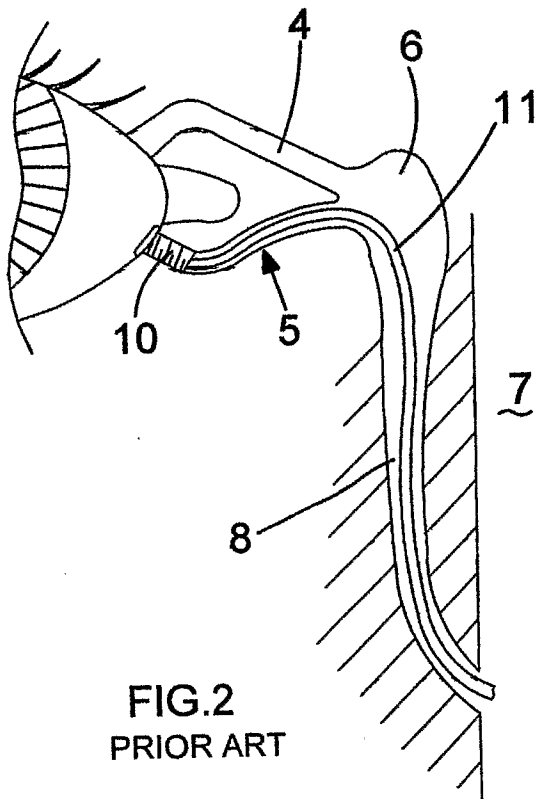
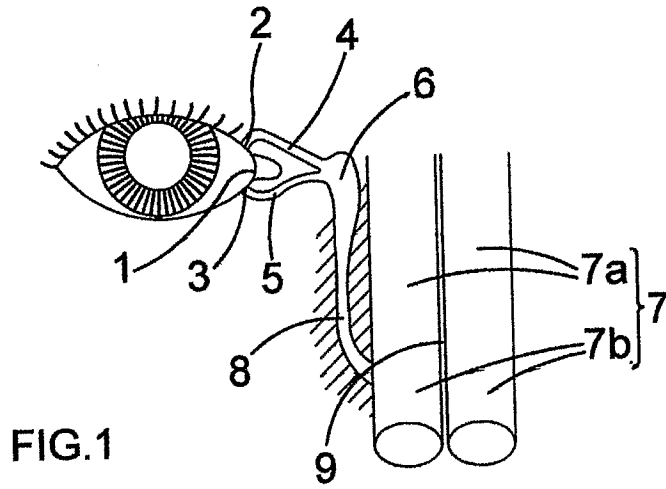

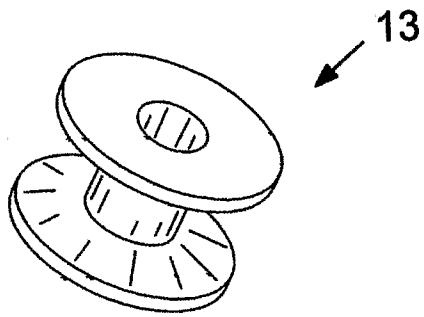

FIG. 4A
PRIOR ART

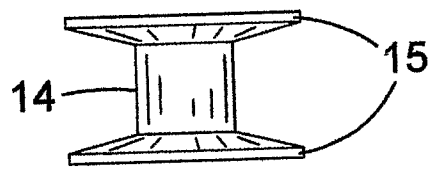

FIG. 4B
PRIOR ART

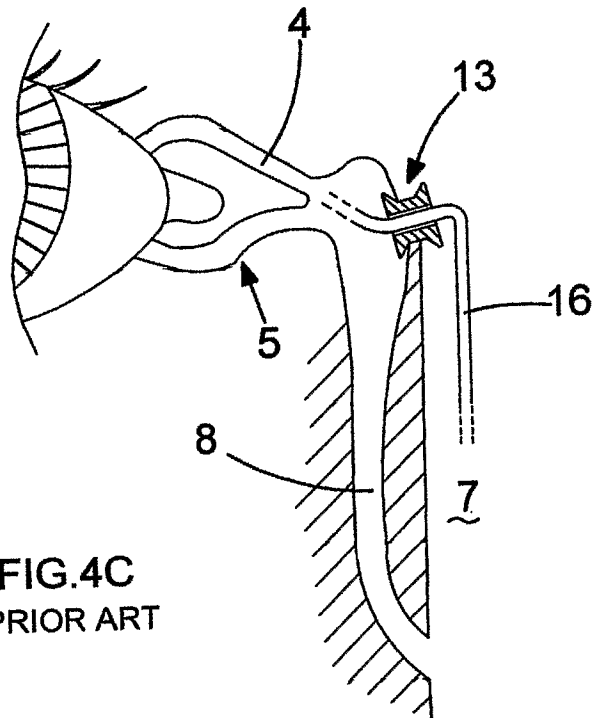

FIG. 4C
PRIOR ART

3/6

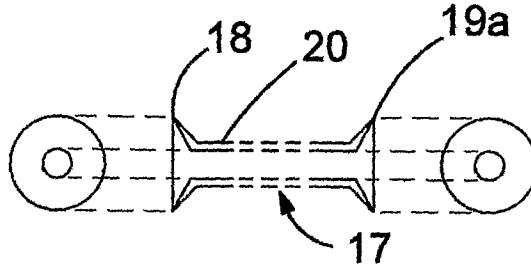

FIG. 5A
PRIOR ART

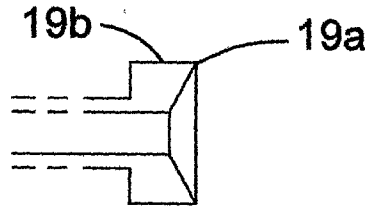

FIG. 5B
PRIOR ART

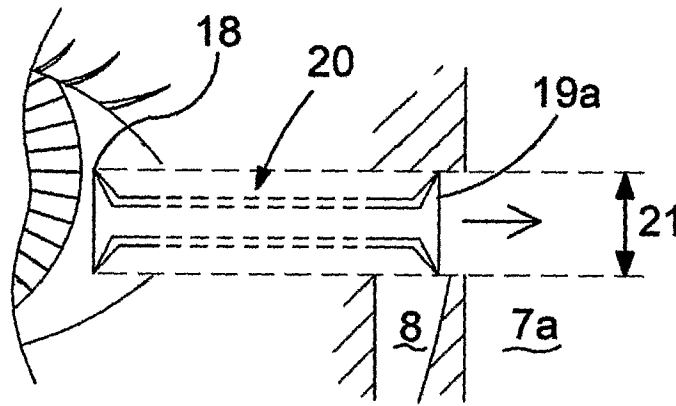

FIG. 5C
PRIOR ART

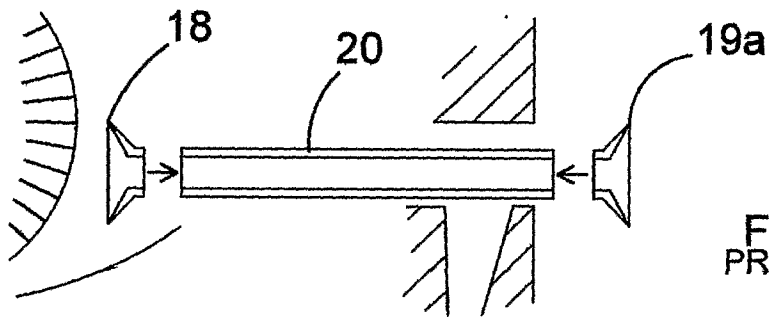

FIG. 5D
PRIOR ART

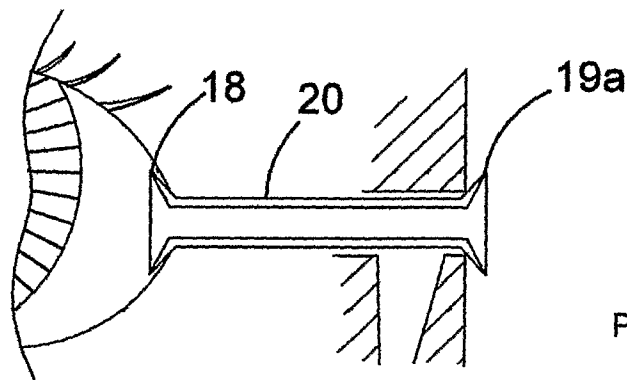

FIG. 5E
PRIOR ART

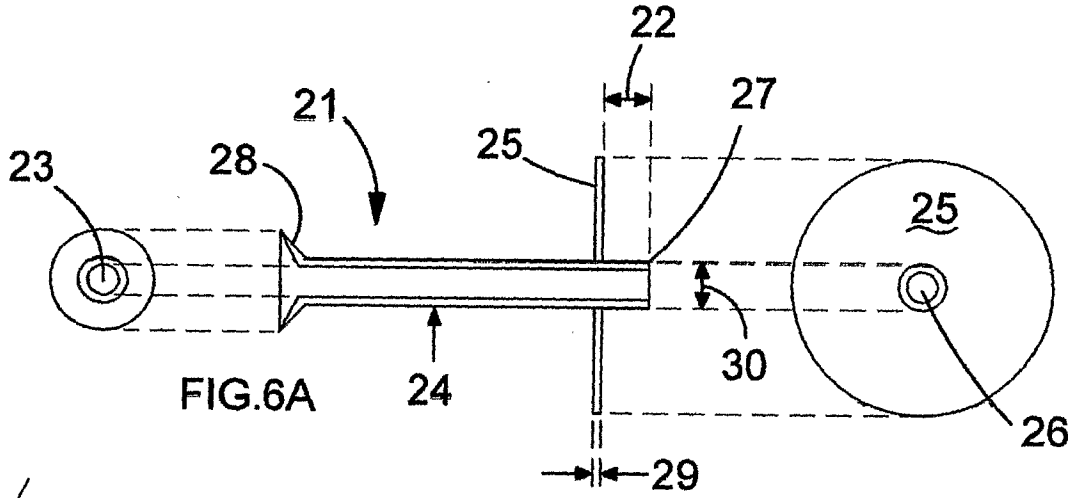

FIG. 6A

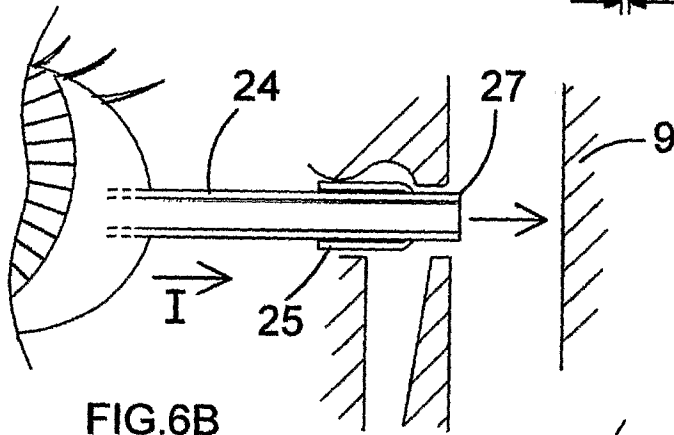

FIG. 6B

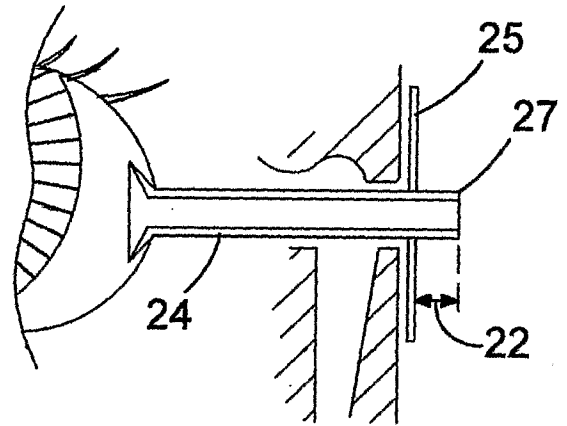

FIG. 6C

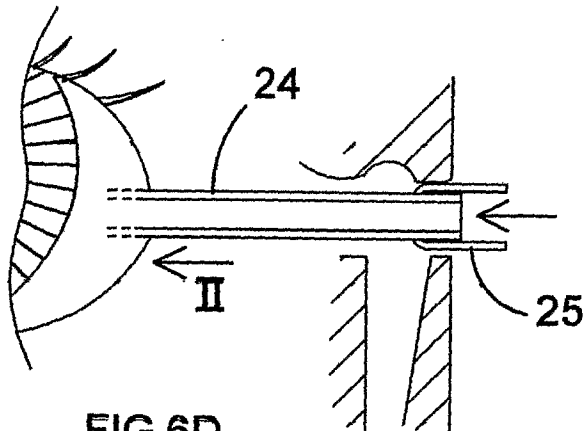
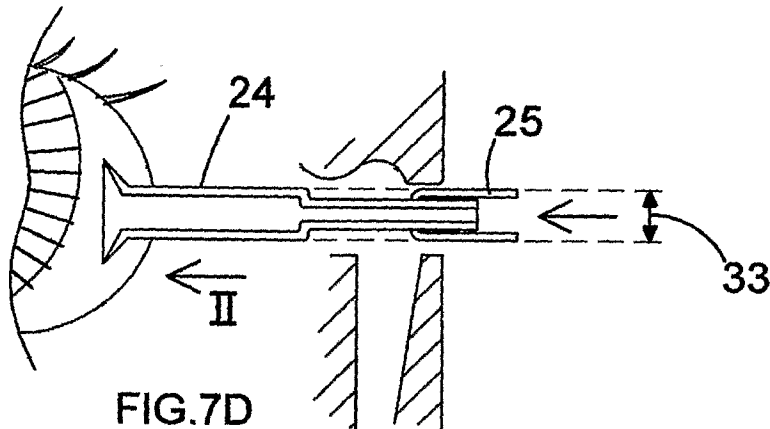
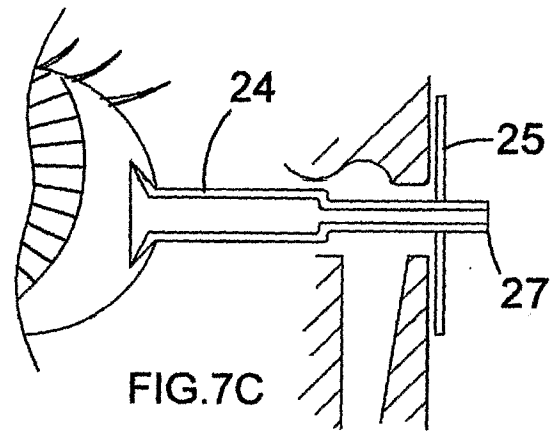
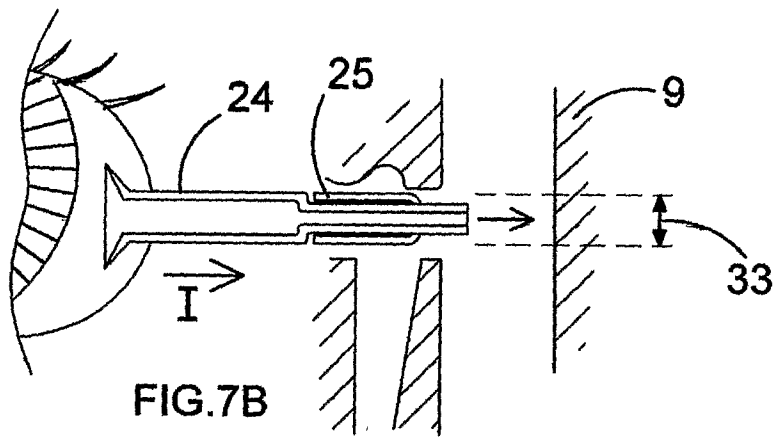
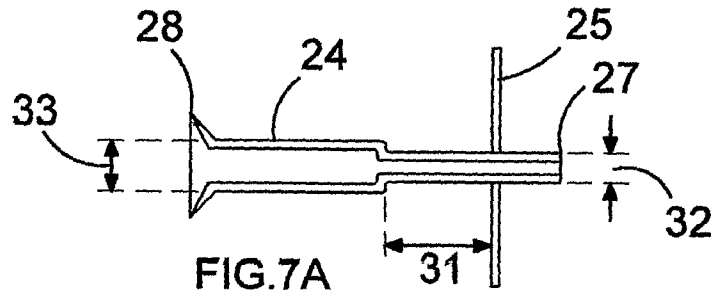

FIG. 6D



6/6

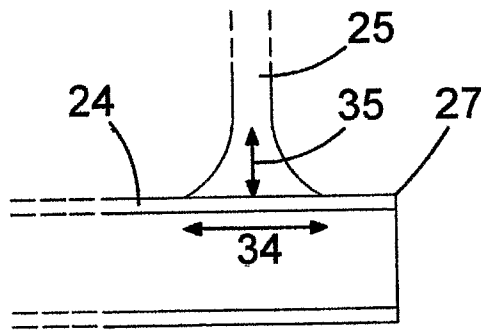

FIG. 8A

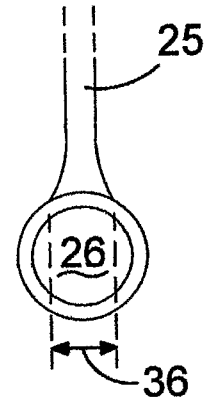

FIG. 8B

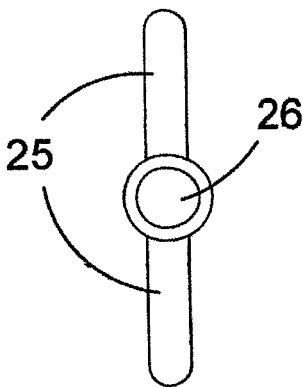

FIG. 9A

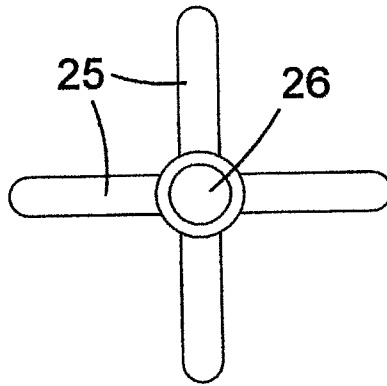

FIG. 9B

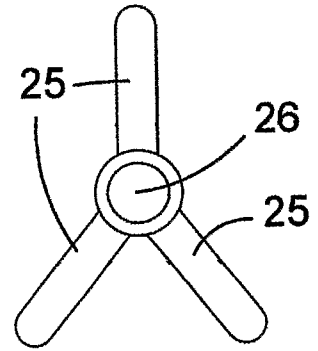

FIG. 9C

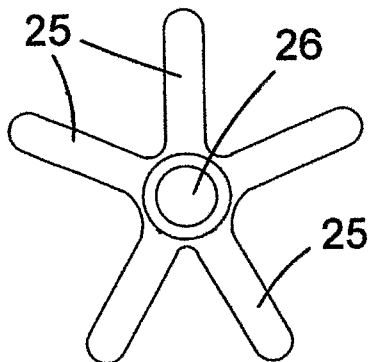

FIG. 9D

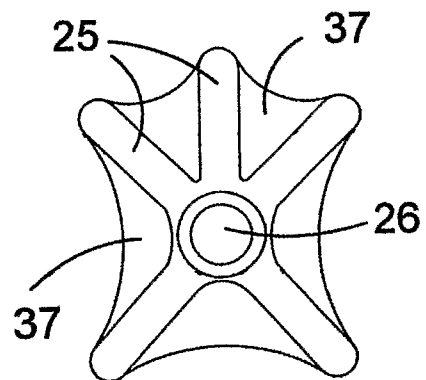

FIG. 9E

INTERNATIONAL SEARCH REPORT

International application No
PCT/GB2007/003408

A. CLASSIFICATION OF SUBJECT MATTER INV. A61F9/007		
According to International Patent Classification (IPC) or to both national classification and IPC		
B. FIELDS SEARCHED		
Minimum documentation searched (classification system followed by classification symbols) A61F		
Documentation searched other than minimum documentation to the extent that such documents are included in the fields searched		
Electronic data base consulted during the international search (name of data base and, where practical, search terms used) EPO-Internal, WPI Data		
C. DOCUMENTS CONSIDERED TO BE RELEVANT		
Category*	Citation of document, with indication, where appropriate, of the relevant passages	Relevant to claim No.
Y	GB 2 273 243 A (KAYARKAR VISHWAS VASANT [GB]) 15 June 1994 (1994-06-15) page 1, lines 19-21,41,42 page 2, lines 7-47 -----	1-11
Y	US 2006/100700 A1 (BERNARD PASCAL [FR] ET AL) 11 May 2006 (2006-05-11) paragraphs [0006] - [0017], [0033] - [0040], [0058], [0071] - [0073], [0091] figures 1B,2B,3B,4A,6,7 ----- -/--	1-11
<input checked="" type="checkbox"/> Further documents are listed in the continuation of Box C. <input checked="" type="checkbox"/> See patent family annex.		
* Special categories of cited documents :		
A document defining the general state of the art which is not considered to be of particular relevance *E* earlier document but published on or after the international filing date *L* document which may throw doubts on priority claim(s) or which is cited to establish the publication date of another citation or other special reason (as specified) *O* document referring to an oral disclosure, use, exhibition or other means *P* document published prior to the international filing date but later than the priority date claimed	*T* later document published after the international filing date or priority date and not in conflict with the application but cited to understand the principle or theory underlying the invention *X* document of particular relevance; the claimed invention cannot be considered novel or cannot be considered to involve an inventive step when the document is taken alone *Y* document of particular relevance; the claimed invention cannot be considered to involve an inventive step when the document is combined with one or more other such documents, such combination being obvious to a person skilled in the art. *&* document member of the same patent family	
Date of the actual completion of the international search <p align="center">10 December 2007</p>		Date of mailing of the international search report <p align="center">21/12/2007</p>
Name and mailing address of the ISA/ European Patent Office, P.B. 5818 Patentlaan 2 NL - 2280 HV Rijswijk Tel. (+31-70) 340-2040, Tx. 31 651 epo nl, Fax: (+31-70) 340-3016		Authorized officer <p align="center">Rapp, Alexander</p>

INTERNATIONAL SEARCH REPORT

International application No
PCT/GB2007/003408

C(Continuation). DOCUMENTS CONSIDERED TO BE RELEVANT		
Category*	Citation of document, with indication, where appropriate, of the relevant passages	Relevant to claim No.
P, X	WO 2006/133066 A (BECKER BRUCE B [US]) 14 December 2006 (2006-12-14) page 4, line 24 - page 5, line 9 page 5, lines 20-24 page 6, lines 5-14 page 8, line 30 - page 9, line 6 page 12, line 23 - page 13, line 2 page 15, lines 1-18 page 18, lines 1-7 page 20, lines 10-26 -----	1

INTERNATIONAL SEARCH REPORT

Information on patent family members

International application No PCT/GB2007/003408
--

Patent document cited in search report	Publication date	Patent family member(s)	Publication date																								
GB 2273243	A	15-06-1994	NONE																								
US 2006100700	A1	11-05-2006	<table style="width: 100%; border-collapse: collapse;"> <tr> <td style="width: 15%;">CA</td> <td style="width: 25%;">2491799</td> <td style="width: 15%;">A1</td> <td style="width: 45%;">15-01-2004</td> </tr> <tr> <td>CN</td> <td>1671338</td> <td>A</td> <td>21-09-2005</td> </tr> <tr> <td>EP</td> <td>1519700</td> <td>A2</td> <td>06-04-2005</td> </tr> <tr> <td>FR</td> <td>2841770</td> <td>A1</td> <td>09-01-2004</td> </tr> <tr> <td>WO</td> <td>2004004614</td> <td>A2</td> <td>15-01-2004</td> </tr> <tr> <td>JP</td> <td>2005532103</td> <td>T</td> <td>27-10-2005</td> </tr> </table>	CA	2491799	A1	15-01-2004	CN	1671338	A	21-09-2005	EP	1519700	A2	06-04-2005	FR	2841770	A1	09-01-2004	WO	2004004614	A2	15-01-2004	JP	2005532103	T	27-10-2005
CA	2491799	A1	15-01-2004																								
CN	1671338	A	21-09-2005																								
EP	1519700	A2	06-04-2005																								
FR	2841770	A1	09-01-2004																								
WO	2004004614	A2	15-01-2004																								
JP	2005532103	T	27-10-2005																								
WO 2006133066	A	14-12-2006	US 2006276738 A1 07-12-2006																								