

(12) INTERNATIONAL APPLICATION PUBLISHED UNDER THE PATENT COOPERATION TREATY (PCT)

(19) World Intellectual Property Organization  
International Bureau



(43) International Publication Date  
25 May 2001 (25.05.2001)

PCT

(10) International Publication Number  
WO 01/35715 A2

(51) International Patent Classification: Not classified

(21) International Application Number: PCT/IB00/01831

(22) International Filing Date:  
17 November 2000 (17.11.2000)

(25) Filing Language: English

(26) Publication Language: English

(30) Priority Data:  
60/166,274 18 November 1999 (18.11.1999) US

(71) Applicant and

(72) Inventor: BESSELINK, Petrus [NL/NL]; Gronausestraat  
1220, NL-7534 AT Enschede (NL).

DK, DM, EE, ES, FI, GB, GD, GE, GH, GM, HR, HU, ID,  
IL, IN, IS, JP, KE, KG, KP, KR, KZ, LC, LK, LR, LS, LT,  
LU, LV, MA, MD, MG, MK, MN, MW, MX, MZ, NO, NZ,  
PL, PT, RO, RU, SD, SE, SG, SI, SK, SL, TJ, TM, TR, TT,  
TZ, UA, UG, US, UZ, VN, YU, ZA, ZW.

(84) Designated States (*regional*): ARIPO patent (GH, GM,  
KE, LS, MW, MZ, SD, SL, SZ, TZ, UG, ZW), Eurasian  
patent (AM, AZ, BY, KG, KZ, MD, RU, TJ, TM), European  
patent (AT, BE, CH, CY, DE, DK, ES, FI, FR, GB, GR, IE,  
IT, LU, MC, NL, PT, SE, TR), OAPI patent (BF, BJ, CF,  
CG, CI, CM, GA, GN, GW, ML, MR, NE, SN, TD, TG).

**Published:**

— *With declaration under Article 17(2)(a); without classification and without abstract; title not checked by the International Searching Authority.*

(81) Designated States (*national*): AE, AL, AM, AT, AU, AZ,  
BA, BB, BG, BR, BY, BZ, CA, CH, CN, CR, CU, CZ, DE,

*For two-letter codes and other abbreviations, refer to the "Guidance Notes on Codes and Abbreviations" appearing at the beginning of each regular issue of the PCT Gazette.*



WO 01/35715 A2

(54) Title: METHOD FOR PLACING BIFURCATED STENTS

(57) Abstract:

-1-

## METHOD FOR PLACING BIFURCATED STENTS

The present invention generally relates to methods of placing an expandable endoluminal prosthetic device, commonly referred to as a stent, and more particularly to a method of placing a bifurcated stent structure such that only a single incision into a patient need be made.

Stents are used in a variety of places in the human body to support various anatomical lumens, such as blood vessels, respiratory ducts, gastrointestinal ducts and the like. Conventionally, stents are deployed in regions of stenosis or constriction in the target body lumen to hold the lumen open, thus obtaining a patent lumen and preventing immediate or future occlusion or collapse of the lumen and the resultant obstruction of fluids flowing therethrough. Because stent implantation is a relatively non-invasive procedure, it has proven to be a favorable alternative to surgery in many cases, for example, in certain cases of vascular stenosis. Bifurcated stents, with their trunk and branching configuration (typically including two branches of different size), are particularly well-suited for use in branching body lumen systems, such as in the coronary vasculature (which include the right, left common, left anterior descending and circumflex arteries and their branches) and the peripheral vasculature (including branches of the carotid, aorta, femoral, popliteal, and related arteries). Placement of such a bifurcated stent can be rather complicated, because there may be a need to approach the bifurcated section of the artery through at least two side branches or through the trunk plus one side branch. This procedure can be not only time-consuming, but also lead to more incision sites in the patient's body, as well as necessitate more complicated maneuvers for the surgeon. Procedures for placement of a bifurcated stent are described in U.S. patents 5,720,735, entitled "Bifurcated endovascular catheter" and 4,994,071, entitled "Bifurcating stent apparatus and method". In these patents, which are representative of the state of the art, each of the branches has a dedicated guide wire to guide the placement of balloons, stents, stent grafts or grafts into a bifurcated anatomical lumen. This redundancy can lead to increases in the overall size, cost and complexity of such devices.

Accordingly, there exists a need to insert bifurcated stents into a body lumen where the stent configuration is such that simpler surgical procedures are enabled, with

-2-

concomitant decrease in incision number or size and related invasive steps, thereby reducing patient trauma associated with complex medical procedures.

This need is met by the present invention, where the procedure of placement of a stent becomes simplified by the use of a single delivery catheter, using only a single  
5 incision in only one location. Thus, the disclosed procedures can be used for placing non-bifurcating stents in a side branch of a bifurcating lumen, as well as for placement of all kinds of bifurcating stents anywhere in the body, with or without a graft. Furthermore, expansion of the stents can be effected by plastic deformation due to balloon pressure, or triggering of elastically stored energy in the stent (such as with  
10 bistable stents or elastic or superelastic expansion). It is through the relative axial movements of the coaxial components in the system that this method exhibits simple operation coupled with unobtrusive cross-sectional dimensions. Operability is further enhanced by the inclusion of position-indicating markers with steerable features. Such a marker configuration provides readily-apparent indicia of the angular position of the  
15 device to enable accurate positioning at the distal end. To enhance patient safety, each of the following embodiments may optionally include a flexible housing that can follow the angular movements between the branches easily, while it smoothens the functioning of the device.

According to an aspect of the present invention, a method for inserting, deploying  
20 and removing a surgical device is disclosed. Preferable surgical devices include bifurcated endoluminal stents, stent-grafts, grafts and balloon angioplasty mechanisms. While it can be readily appreciated that the method described herein is applicable for use numerous endoluminal devices, and in a variety of bifurcated body lumens, the subsequent discussion will be limited to the example of a bifurcated stent for use in  
25 preventing an abdominal aortic aneurysm (hereinafter referred to as triple A). Such a device is commonly known as a triple A graft stent. The stent is brought into place by advancing the whole stent in a delivery catheter with restraining sheath through one main side branch artery in a patient's leg. The distal end of the catheter holding the stent is inserted until it arrives adjacent the aneurysm area, with the lower ends of the branches  
30 beyond the body lumen bifurcating point, where the aorta divides itself into the two common iliac arteries. Upon insertion beyond this bifurcating point, the restraining sheath is pulled back, thereby exposing the unconnected ends of the two branches. The

-3-

stent is still in its unexpanded state, but the elasticity of the two branches of the stent tends to create an angle between the two hingedly connected branches. In the present context, two or more members are considered to be hingedly connected when they are joined at a common end, regardless of how they are attached, such that only relative rotational movement (with no translational component) is permitted at such connected end, while the opposing unconnected ends are free to move relative to one another, constrained only by resistive forces operating at the connected end. A resiliently biased connection could include hingedly connected members that exhibit elastically deformable properties such that upon removal of a constraining force, the members would revert back to a predetermined unconstrained spacing relative to one another. By proper engineering choice of the elastic force, the amount of spread between the unconnected ends of the branches is such that they can gently be pulled back into their respective arteries, while the trunk section of the stent is also pulled back into the final artery section, where the aneurysm is located.

Once the stent is properly positioned relative to the iliac arteries and the lower aorta, the whole stent can be expanded into the final shape, by, for example, a conventional expander (typically a balloon) located within the delivery catheter. The balloon can either be made from one single piece, with the same overall shape as the bifurcated stent, or from several sections that can be inflated at different moments. With such a bifurcated balloon, the whole stent can be expanded without repositioning of the balloon and, if needed, it can be done very fast, thus reducing critical operation time. After deflating, the balloon can then be moved in the catheter insertion direction until the free end of the side branch of the balloon not directly connected to the catheter is moved completely beyond the body lumen bifurcation point and into the trunk section of the aorta. The two branches of the bifurcating balloon have been made elastic as well, but in a different way than the branches of the stent, such that they are biased to a substantially parallel orientation in line with the trunk of the balloon. One way this biasing can be achieved is by using two elastic spring wires, strips or tubes made from straight superelastic Nitinol, or related shape-memory material, disposed either in or outside the center of the balloon branches, coming together in or near the center of the balloon trunk. Thus, there are two opposing forces in the complete assembly of a bifurcating stent with a bifurcating balloon inside: while the branches of the stent have to move apart

-4-

for placement, the branches of the balloon have to move together for easier removal. This means that during the insertion phase, the elastic opening force of the stent branches has to be larger than the biasing elastic closing force of the balloon branches, and that during withdrawal phase, the elastic closing force of the stent-less balloon ensures a minimal cross-sectional profile and consequent ease of removal from the patient. Thus, once the stent has been deployed, and the catheter with the deflated balloon has been pushed into the trunk section of the aorta, the balloon branches snap back to their parallel position and the whole catheter with the deflated balloon can be withdrawn from the body through the incision site. For additional safety and reduction of the pull-out force required, the restraining delivery sheath can be pushed over the two proximal ends of the branches of the balloon. An elastic sleeve can optionally be used to surround the balloon, thereby minimizing the balloon geometry after deflation by applying a biasing load on the balloon. This acts to decrease deflation time, as well as control the timing of inflation over the balloon length or influence the final dimensions during and after inflation.

In situations where it is desirable to use self-expanding stents, a similar catheter is used as for the balloon-expandable stents, where now the bifurcated balloon is replaced by a bifurcated delivery sheath, that works in cooperation with tension and pushing elements for removal of the delivery sheath from the stent surface.

According to another aspect of the present invention, a single stent can be placed into a side branch of the body lumen, which has proven to be difficult to reach with conventional catheters. Sometimes the side branch makes an angle of less than 90 degrees with the proximal side of the main lumen, permitting a catheter to be used to put an angioplasty balloon or stent into place. This is done by the use of a long main catheter in combination with a side branch that contains the angioplasty balloon or stent. After bringing the parallel trunk and side branch sections beyond the bifurcation point, the restraining sheath that held the sections parallel is removed. Then the side branch is allowed to create an angle with the trunk section and the catheter is pulled back in proximal direction, while the side branch of the catheter enters the lumen that has to be treated. After deployment of the angioplasty or stent device, the catheter is pushed into the initial direction of insertion until the side branch is beyond the bifurcation point. The catheter sections are then brought into their parallel position, eventually secured by a

-5-

restraining means and then the whole device is pulled out through the initial insertion location.

Other objects and advantages of the invention will become more apparent after reference to the following description, the accompanying drawings and the appended  
5 claims.

Figure 1 shows the first step of the insertion of delivery catheter with balloon, stent and a delivery sheath upon insertion into an aorta, according to an aspect of the present invention;

Figures 2 - 7 show additional steps according to an aspect of the present invention;

10 Figure 8 shows the first step of the insertion of delivery catheter with balloon, stent and a delivery sheath upon insertion into an aorta, according to an alternate aspect of the present invention;

Figures 9 - 14 show additional steps according to an alternate aspect of the present invention;

15 Figures 15a - 15f show the insertion of a catheter for angioplasty or placement of a single stent in a side branch, according to another aspect of the present invention; and

Figures 16a and 16b show a catheter for angioplasty or placement of a single stent in a side branch with a pull wire at the distal end of the side branch.

Figure 1 shows an aorta 10 with an aneurysm 11 and two common iliac arteries  
20 12a and 12b. A delivery catheter 20 with proximal and distal ends 20a and 20b, respectively, and unexpanded balloon 21 is shown inserted into the aorta 10, carrying with it a bifurcated stent 22 with branch sections 22a and 22b and trunk section 22c. A retractable delivery sheath 23 disposed on distal end 20b of delivery catheter 20 holds the branch sections 22a and 22b in parallel. The current stent 22 is shown schematically  
25 as a series of expandable rings, connected by a longitudinal backbone element. The geometry of the stent 22 can be any conventional balloon expandable kind and is therefore not described in further detail. The sheath 23 encases a central catheter body 24 that is inserted into a patient at some remote location, such as in a leg. The catheter 20 is strong and stable enough to enable relative displacement between the central  
30 catheter body 24 and delivery sheath 23. Further, it is desirable that the catheter 20 is made steerable over the range of insertion such that, upon application of a torsional force by a user's hand, it can be easily positioned in the patient's body. If the stent 22

-6-

is of the balloon-expandable genre, central catheter 24 further requires a lumen to transport expansion fluid (such as pressurized air) from an external source and into the balloon to provide sufficient expansion force.

The proximal end of catheter body 24 includes a marker 25 to enable a user to  
5 check the longitudinal position in relation to a similar marker 26 located on delivery sheath 23. Comparison of the distance between markers 25 and 26, shown as X, allows the user to determine the position of the two branches 22a and 22b relative to the end of sheath 23. The markers 25 and 26 additionally function to provide the user with readily apparent visual information about the rotational position of the two branches 22a  
10 and 22b in relation to the position of the two common iliac arteries 12a and 12b.

Figure 2 shows the retraction of delivery sheath 23 so that the branches 22a and 22b are released, enabling them to open up. Thus, when the markers 26 and 25 are brought together, the stent 22 and balloon 21 are outside the sheath 23. Furthermore, marker 25 provides positive indication that branch 22b is positioned correctly with respect  
15 to iliac artery 12b, as it points to the right (as depicted in the figure) when branch 22b is aligned with iliac artery 12b. The stent 22, through predetermined elastic properties, has a tendency to create an angle A between branches 22a and 22b, where they split from the trunk section 22c at the stent bifurcating point 22d. This tendency to open up can be caused by elastic energy that is stored in the surface of the structure of stent 22. In  
20 addition to configurational choices, the elastic properties of the stent can be controlled by proper material choices, where polymers, metals, memory materials with superelastic or temperature dependant behaviour, organic materials, ceramics and combinations thereof can be especially useful. This is particularly true when used for the basic elements that enable catheter functioning, namely the bifurcating core wires that interact  
25 with the opening force of the stent branches. For example, a very suitable material would be Nitinol, a nickel-titanium alloy with shape-memory properties, because of the high allowable elastic strain and the stable forces over a high strain range. The branch portions of the stent can be programmed to take a preferable parallel position by means of heat treatment of the Nitinol. To augment the angle-closing bias, an additional sleeve  
30 or ring can be pulled over the bifurcating point of the core wire, thereby keeping them together. The tendency of the stent branches to open up their relative angle can also be influenced by some additional elastic wires, strips, tubes or sheaths, made from

-7-

Nitinol or any other suitable material. Designed-in elastic properties can alternatively come from additional backbone-like elements that connect a series of ring segments of the stent in an axial direction, or could be stored in some other body, such as a segment of graft material brought in place together with the stent.

5           Figure 3 shows the catheter 20 with the deflated balloon 21 and unexpanded stent 22 are brought into position by pulling back on the catheter 20 until body lumen bifurcation point 12c of aorta 10 and stent bifurcation point 22d are brought into their desirable relative position. The angular bias provided by the branch portions 22a and 22b ensures that when catheter 20 is pulled back, stent bifurcation point 22d will seat  
10 itself adjacent body lumen bifurcation point 12c. When this occurs, stent 22 is ready for expansion in order to reach the walls of the arteries.

          Figure 4 shows stent 22 in an expanded state. Catheter body 24, until now drawn as a line for ease, ends in the balloon in a central spring element, with a first branch section 27a and a second branch section 27b both coming together in bifurcation point  
15 27c to form trunk section 27. This central spring element has the tendency to close the angle A between the branches, and further serves as a framework for the surrounding balloon sections 21a and 21b for the branches and 21 above the bifurcating point 21c. Catheter 24 with its fluid supply lumen(s) (not shown) connects to the balloon section. In one embodiment the spring element is made hollow and also acts as a fluid supply  
20 lumen for the balloon sections. By means of side holes in this hollow spring element the fluid can enter into the balloon sections for inflation. If desired, the pattern and sequence of inflation of the different balloon sections can be controlled in time by having multiple fluid lumens in catheter body 24 that are connected to multiple lumens in the hollow spring elements 27. An alternative method, that only requires a single fluid lumen, is the  
25 use of a surrounding biasing sleeve that hinders the inflation of balloon sections in a different way along the length of the balloon. The active biasing pressure of the sleeve can determine the threshold pressure for inflation, and so the sequence of expansion of the stent 22 can be controlled. The tendency of the stent 22 branch portions 22a and 22b to create angle A in figure 2 is strong enough to overcome the biasing force of the  
30 spring elements 27a and 27b, which would otherwise tend to close the angle A between the legs of the balloon. An example of an elastic element in the stent 22 that has to have



-8-

the tendency to open up the angle is shown as the backbone elements 22e and 22f, integrated in the surface of the stent 22.

Figure 5 shows the catheter in the same position as in figure 4, with the expanded stent 22 in its final position. The stent 22 sections 22a through 22d form a tight fit with the surrounding aorta 10. Stent 22 can also be used with a graft that surrounds, or is surrounded wholly or partly by it. Balloon sections 21, 21a and 21b return to their smaller, as-inserted diameter and surround the spring elements 27, 27a and 27b as close as possible to diminish the final extraction size of the catheter. This can be achieved by making the balloon from either an elastic material, or by combining an elastic biasing material with a less compliant underlying balloon section (not shown). Despite the tendency of the branches to go to their preferable parallel position, the legs are kept open because they touch the inner wall of the stent 22 near bifurcating point 22d.

Figure 6 shows how the catheter has been moved farther into the aorta 10, where the branches of the balloon section spring back to their preferable parallel position. The stent 22 is left in place and the delivery sheath is still in the relative position of figures 2-5, but it can be pushed such that its unconnected ends are beyond body lumen bifurcation point 12c.

Figure 7 shows the catheter with the delivery sheath 23 reinserted over the ends of the balloon branches 21a and 21b over distance X of figure 1, to enable removal from the patient's body. This lowers friction and the risk of injury that could be caused by the free end of the branch 27b piercing the artery wall upon withdrawal. The size of the deflated balloon of figures 5 - 7 need to be smaller than the inner diameter of the expanded stent to enable a free movement of the catheter and its branches upon removal. In this regard, the use of a biasing sleeve around the balloon can be very helpful in not only maintaining the concentric, circular cross section of the balloon upon deflating, but also by minimizing its size. Further, the active biasing forces of the elastic sleeve can speed the deflation process.

Figure 8 shows the aorta 10 with an aneurysm 11 and the two common iliac arteries 12a and 12b plus a delivery catheter 29 with three stent-sheaths 30, 31 and 32, surrounding a self-expanding stent with sections 33, 34 and 35 for trunk and branches respectively. The delivery catheter 29 has a main core wire 40 that can be pushed and

pulled by the user, and a surrounding delivery sheath 41 with a wider end 42, that holds the stent sections parallel. Main wire 40 has a bifurcation point 43, a trunk section 44 and 45 with a mechanical stop 44a and two branch sections 46 and 47.

Figure 9 shows how the delivery sheath is pulled back to release the stent branches 34 and 35 and enable them to open up. The stent sheaths 31 and 32 are still surrounding the unexpanded stent branches.

Figure 10 shows how the catheter with the unexpanded stent and surrounding stent sheaths are brought into position by pulling back of the catheter in a manner similar to that of figure 3.

Figure 11 shows how the bifurcated core wire of the catheter has pushed the stent sheath 31 of the left branch 34 downward to release this left branch of the stent. The lower tip of the left branch wire 46 is attached to the stent sheath 31 at its end point 50 to be able to apply an effective pulling force to the sheath. This design gives a smoother release than when the sheath had to be pushed. The bifurcation point 43 of the main wire was originally above the bifurcation point of the stent, as can be seen in figure 8. Now it has moved downward while stent sheath 31 was pushed down and the distal end 44 of the main wire has slid downward through a top hole in the stent sheath 30 of the trunk section. The mechanical stop 44a has slid downward together with the main wire.

Figure 12 shows how the trunk section of the bifurcated core wire of the catheter has pushed the stent-sheath of the trunk section of the stent 33 upward to release the trunk section of the stent. The function of mechanical stop 44a is that the main wire 44 can slide freely through the hole in stent-sheath 30, but having reached the position of stop 44a the stent-sheath needs to be pushed up. This force is taken up by stop 44a (its diameter is slightly larger than the hole size). It further shows how the catheter has been moved into the higher aorta, where the branches of the catheter spring back to their preferable parallel position. Further, a second wire 48 with mechanical stop 49 is shown. This wire is attached to the lower end of the stent sheath 32 of the right branch and serves to pull this stent-sheath downward. This pulling wire 48 can run completely parallel to main wire 40 and leave the patient's body at the proximal end of the catheter, although this is not necessary. The pulling wire 48 can run freely through a small hole in the flange of delivery sheath 42 until it reaches mechanical stop 49. From that position the surgeon can pull delivery sheath 41 and thus also section 42 down and this

-10-

sheath takes via wire 48 the stent sheath 32 down to release stent branch 35. Figure 12 also shows how this downward movement of sheath 41 has been completed and how it has pulled the final stent sheath 32 of the right branch off.

Furthermore, in figure 13, the main wire 40 has been pulled down to bring the other two stent-sheaths down through the expanded stent sections. Now the lower two branches are lying beside each other again.

Figure 14 gives the catheter with the delivery sheath 42 shifted upward over the ends of the catheter branches to enable removal from the patient's body. Pulling wire 48 with stop 49 now extends from sheath 42, but lies tight to the surface of the long smaller-diameter section 41 of this sheath. For the stent sheaths of figures 8-14, it is also helpful if the size is minimized before such a sheath has to be moved through a stent. As long as the stent sheath surrounds the self-expanding stent, the size is determined by the outer diameter of this stent, eventually together with a graft material. However, after having pushed out the stent from this stent sheath, the stent sheath is empty and cocoon-like. One way to minimize the size is by an elastic sheath that surrounds the stent sheath. In other aspect, the biased sheath must be relatively non-elastic to avoid inadvertent discharge of the stent disposed therein. This works the best with a rather rigid material with a well-defined geometry and maximum inner diameter that fits well around the stent. For the biasing sleeve around this stent sheath, the function is to crush the inner sleeve with a radial compression force to make it as small as possible. In this situation, elastic materials for the sleeve are preferable. The interaction between the compressed stent, the stent sheath and the biasing sheath has to be optimized to achieve the best combination of easy delivery of the stent plus small cross-sectional profile for the catheter upon removal. As has been shown in figures 8-14, the catheter makes use of some free play of the core wire to enable a series of axial movements through the stent-trunk and its branches. There are many embodiments to elucidate this point. For example, the use of a core wire, surrounded by a thin-walled tube with high flexibility, like a superelastic Nitinol tube, could be utilized. A catheter with such a backbone tube has more longitudinal rigidity and gives a better support for accurate relative movements between the core wire 40 and the delivery catheter sheath 41. Proximal actuation using such a configuration by the user becomes much more controllable.

-11-

Figures 15a through 15f show an alternate method for inserting a stent, where a single stent is placed into a side branch of a body lumen 62. Sometimes the side branch makes an angle of less than 90 degrees with the proximal side of the main lumen and a catheter according to the invention can be used to put an angioplasty balloon or stent into place. In figure 15a, such a bifurcating lumen is shown with a lesion 70 in the right side branch. A long main catheter core wire 50 has a side branch 51 connected at the distal junction 52. The side branch 51 also contains the angioplasty balloon or stent, schematically shown as 60. By means of a relative movement, actuated by wire 53, a restraining sheath 54 can hold the core wire and side branch parallel. As shown in figure 15b, after bringing the parallel trunk and side branch sections beyond the body lumen bifurcation point 62c, the restraining sheath 54 that held the sections parallel is removed by sliding it farther through body lumen 62. As with the first embodiment, markers 55, 56 at the proximal ends of wires 53 and 50 respectively, give information about the relative positions and rotational angle of the distal section in relation to the body lumen 62. The side branch is allowed to create an angle A with the trunk section. As shown in figure 15c, the catheter is pulled back toward the body lumen bifurcation point 62c, while the side branch of the catheter enters the lumen with the lesion 70. As shown in figure 15d, the angioplasty or stent device has been deployed by one of the methods as have been described hereinbefore. Figure 15e shows the catheter being pushed in a distal direction until the side branch is beyond the body lumen bifurcation point 62c. Figure 15f shows the catheter sections 50 and 51 being brought into their parallel position, secured by restraining means 54. After that, the whole device can be pulled out in proximal direction as shown in figure 15f without risk. Alternative ways to create an angle between the main wire and side branch are also possible. One example is the proximal actuation of a wedge ring that is forced between the two parallel wires to push them apart. In this case, the main and side branch wires have a preferable parallel position, so sliding back of the wedge ring allows the closure of the angle between the legs. Using a sliding ring that runs around the main and side branch wire can also reverse this principle. Again, by proximal actuation of this ring the legs can be opened by releasing their preferable open position or forced together by pulling the ring down over the legs. In this embodiment, the sleeve 54 is replaced by a ring that is controlled by a wire similar to wire 55.

There are several options to create and close the angle between the main catheter wire and the side branch. For additional safety, the restraining means plays an important role. As shown in figure 16a, an example of a catheter with main wire 70, side branch 71 and junction point 72 according to the invention is given. The tip 73 of side branch 71 is connected to a thin, flexible wire 74 that runs along 71, junction 72 and all the way down along main wire 70. The wire runs over the surface of the balloon at the side branch (not shown), but inside the stent 80, and is mounted without any tension force. At the proximal side the pulling force  $F_0$  at wire 74 is zero. Figure 16b shows how the catheter can be removed. After angioplasty or stenting, the junction point is moved distally until the tip 73 of the side branch moves beyond the bifurcation point of the body lumen. In order to bring side branch 71 and main wire 70 in their parallel position, the operator pulls at the proximal end of the flexible wire 74 with a force  $F_1$ , while main wire 70 is held still, thus forcing tip 73 of side branch 71 to move closer to main wire 70 and finally into delivery sheath 75. Then the whole device can easily be removed through the left branch of the bifurcating lumen.

Other modifications of this invention beyond these embodiments specifically described here may be made without departing from the spirit of the invention. Accordingly, such modifications are considered within the scope of the invention as limited solely by the appended claims.

-13-

## CLAIMS

1. A method for implanting a bifurcated surgical device having first and second branch portions connected at a surgical device bifurcating point to a trunk portion in such a way that said branch portions are resiliently biased to open to a preferred angle  
5 between them, said method comprising the steps of:
- attaching said surgical device to a bifurcated delivery catheter, where said branch and trunk portions are held substantially parallel by a restraining means disposed on said catheter;
  - routing said surgical device and a distal portion of said catheter into a body lumen  
10 bifurcating point in such a position that both unconnected ends of said branch portions of said surgical device are positioned beyond said body lumen bifurcation point; where said body lumen bifurcation point includes a trunk section and branch sections;
  - releasing said branch portions of said surgical device from said restraining means to enable them to occupy said preferred angle relative to one another;
  - 15 seating said surgical device bifurcation point adjacent said body lumen bifurcation point such that each of said trunk and branch portions of said surgical device are in operative cooperation with respective said trunk and branch sections of said body lumen;
  - causing said surgical device said branch and trunk portions to expand until they come in the desired final state in their respective said trunk and branch sections of said  
20 body lumen;
  - reducing contact between said catheter and said surgical device, thereby effecting return of said catheter to a substantially as-inserted dimension;
  - moving said catheter without said surgical device to a position where a plurality of branches of said catheter can elastically return to a preferable, substantially parallel  
25 state;
  - moving said restraining means over at least a portion of said catheter to secure said plurality of branches in said substantially parallel state; and
  - removing said catheter from the patient's body.

-14-

2. The method according to claim 1, wherein the bias between said branch portions of said surgical device is sufficient to overcome a contrariwise tendency to return to said substantially parallel state for said plurality of branches of said catheter.
3. The method according to claim 1, wherein said bias between said branch portions  
5 of said surgical device is caused by elastic energy which is stored in at least one of said surgical device, an additional elastic backbone element defining at least a part of said surgical device, or said attached graft material.
4. The method according to claim 1 wherein said step of causing said surgical device  
10 portions to expand is performed by inflating bifurcated balloon sections that are mounted on said bifurcated catheter inside said respective surgical device portions.
5. The method according to claim 4, said method including the step of deflating said balloon sections after placement of said surgical device.
6. The method according to claim 5, wherein said inflation and deflation of said  
15 balloon sections is performed by moving a fluid through at least one lumen in said bifurcated delivery catheter.
7. The method according to claim 6, wherein the time of deflation and the final diameter for said balloon sections are minimized by surrounding said balloon sections with an elastic biasing sleeve that squeezes said fluid out of said balloon, while helping to maintain the concentric, circular cross section of said deflating balloon sections.
- 20 8. The method according to claim 1 wherein the step of causing the surgical device portions to expand is performed by axial release from surrounding delivery sheaths that hold the surgical device portions in their compressed state.
9. The method according to claim 8, wherein a central bifurcated wire is directly  
25 connected to the free end of a delivery sheath and is used to push or pull the delivery sheath from the surgical device portion.

-15-

10. The method according to claim 8 wherein the release of said surgical device portions from said surrounding delivery sheaths is caused by a series of axial movements of the central bifurcated wire in proximal and distal direction while said surgical device is in a constant axial position relative to the body lumen.

5 11. The method according to claim 10, wherein the wire has some axial free play because it runs free through a small hole in the free end of the delivery sheath, while a mechanical stop, which is attached to said wire, is able to apply the axial force to said delivery sheath.

12. The method according to claim 1 wherein the step of minimizing the dimensions  
10 of the bifurcated catheter after causing the surgical device portions to expand is performed by the use of an elastic biasing sleeve, surrounding the delivery sheath, which is capable to squeeze the sheath once said surgical device is out of said sheath.

13. The method according to claim 8, wherein the interaction with said patient's body is reduced by surrounding at least a portion of said catheter with a flexible housing to  
15 facilitate angular movement.

14. The method according to claim 13, wherein said housing is made of a polymer, a metal or a combination thereof.

15. The method according to claim 1, wherein said components of said catheter are made from materials comprising polymers, metals, memory materials with superelastic  
20 or temperature-dependent behavior, organic materials, ceramics, or combinations thereof.

16. The method according to claim 1, wherein a plurality of markers at a proximal end of said catheter provide angular position indicia of said surgical device as well as relative axial position of said components within said catheter.



-16-

17. The method according to claim 1, wherein said surgical device is an angioplasty balloon.

18. The method according to claim 1, wherein said surgical device is a stent.

19. A method for bringing a surgical device into a side branch of a body lumen by  
5 means of a bifurcating delivery catheter having a trunk section and a branch section, connected in such a way that an angle between said trunk and branch sections can be varied by axial manipulation of components within said catheter, comprising the steps of:

10 attaching said surgical device in its unexpanded state to said catheter while said angle between said trunk and branch sections is minimized by a restraining means, revealing a substantially parallel state between said trunk and branch sections;

15 routing said surgical device and a distal portion of said catheter into a body lumen near a lumen bifurcating point such that a free end of said branch section of said catheter could enter the branch of the body lumen, if said catheter branches was released from the restraining means;

releasing said free end of said branch portion of said catheter from said restraining means to enable it to hingedly deploy away from said trunk portion, thereby increasing said angle between said trunk and branch portions;

20 bringing said catheter with said surgical device in its said unexpanded state into operative engagement with said bifurcated portion of said body lumen;

expanding said surgical device to a preferred expanded state in said body lumen;

returning said catheter to its as-inserted dimension, thereby facilitating removal from said surgical device;

25 moving said catheter without said surgical device to a position where a plurality of branches of said catheter can elastically return to a preferable, substantially parallel state;

moving said restraining means in axial direction such that said trunk and branch sections of said catheter are brought back into said substantially parallel state; and

removing said catheter from said body.

-17-

20. The method according to claim 19, wherein said restraining means is used to minimize said angle between said trunk and branch portions, while removal of said restraining means causes an increase of said angle.

21. The method according to claim 19, wherein said restraining means is used to  
5 increase the angle between trunk and branch sections, while removal of the restraining means causes a decrease of said angle.

22. The method according to claim 20, wherein said restraining means is a sliding sleeve or ring that surrounds at least a part of said trunk and branch sections, said sleeve or ring being moved axially by a proximally actuated element.

10 23. The method according to claim 20, wherein said restraining means is a flexible wire that is attached to the said end of the branch section, said wire pulling said free end towards the trunk section when it is proximally actuated.

24. The method according to claim 21, wherein said restraining means is a sliding sleeve or wedge ring that is pushed between at least a part of said trunk and branch  
15 sections, said sleeve or ring being moved axially by a proximally actuated element.

25. The method according to claim 19, wherein said components of said catheter are made from materials comprising polymers, metals, memory materials with superelastic or temperature-dependent behavior, organic materials, ceramics, or combinations thereof.

20 26. The method according to claim 19, wherein a plurality of markers at a proximal end of said catheter provide angular position indicia of said surgical device as well as relative axial position of said components within said catheter.

27. The method according to claim 25, wherein said surgical device is placed together with a graft.

-18-

28. The method according to claim 26, wherein said surgical device is placed together with a graft.

29. The method according to claim 19, wherein said surgical device is an angioplasty balloon.

5 30. The method according to claim 19, wherein said surgical device is a stent.

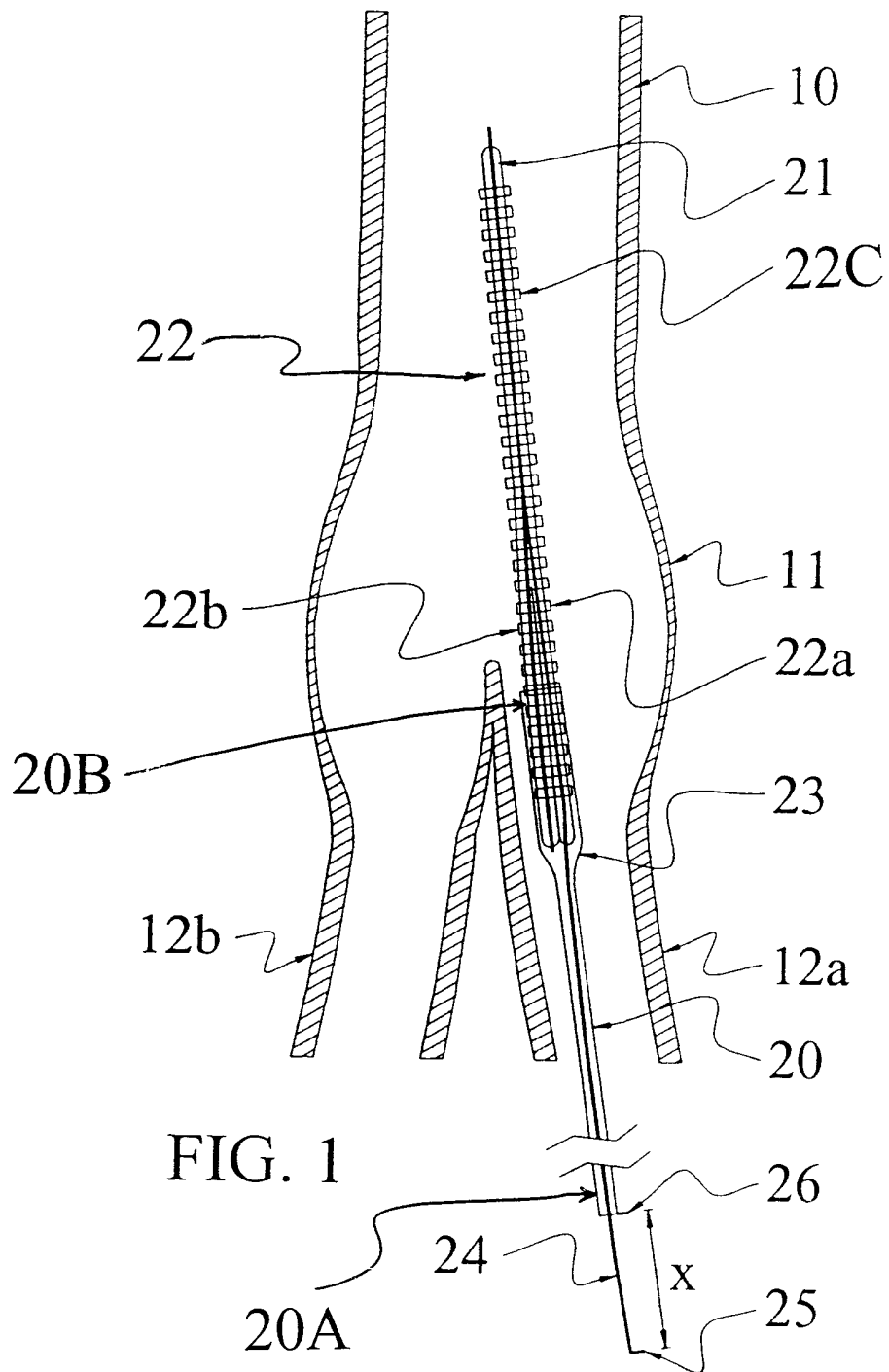

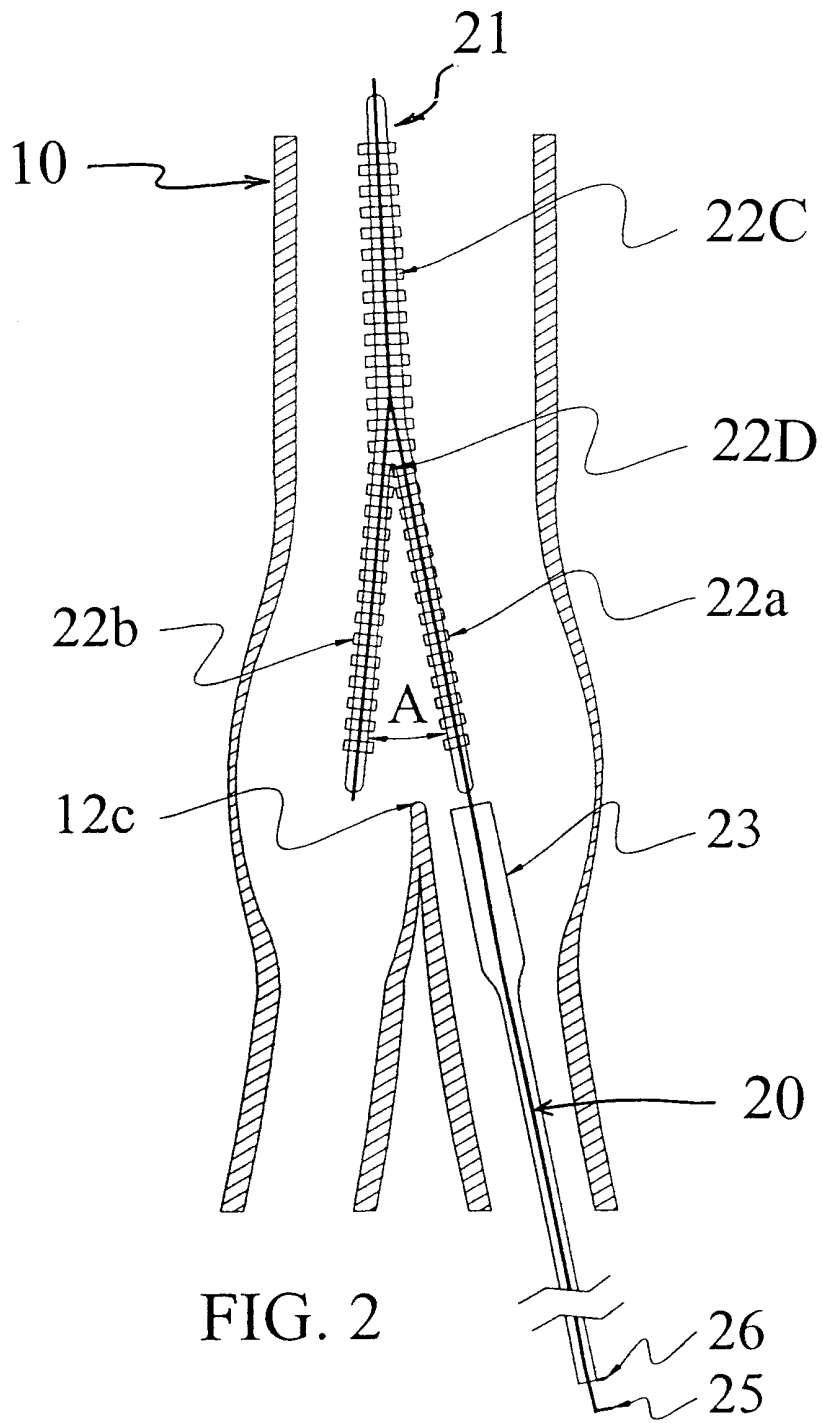
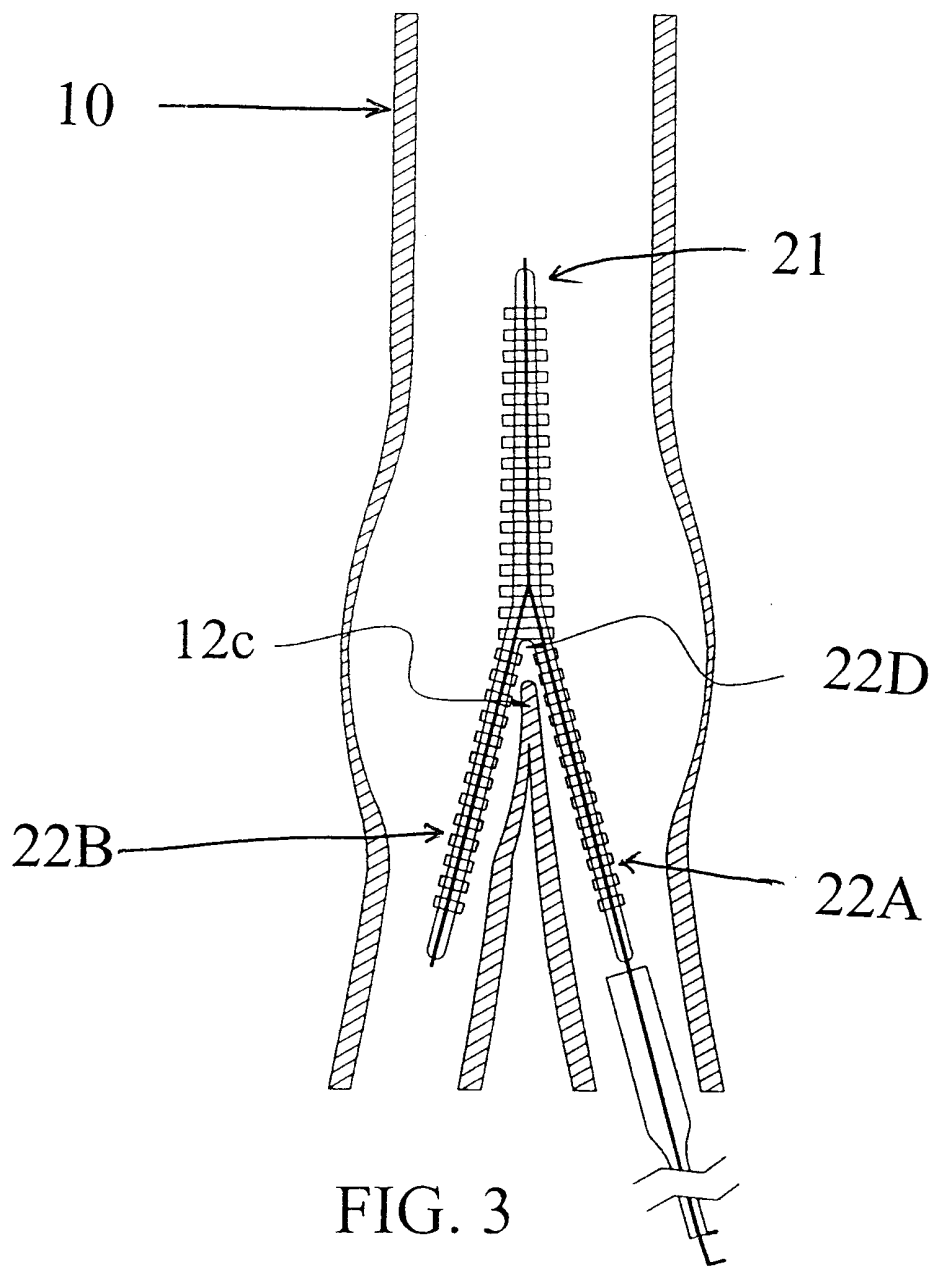

FIG. 2



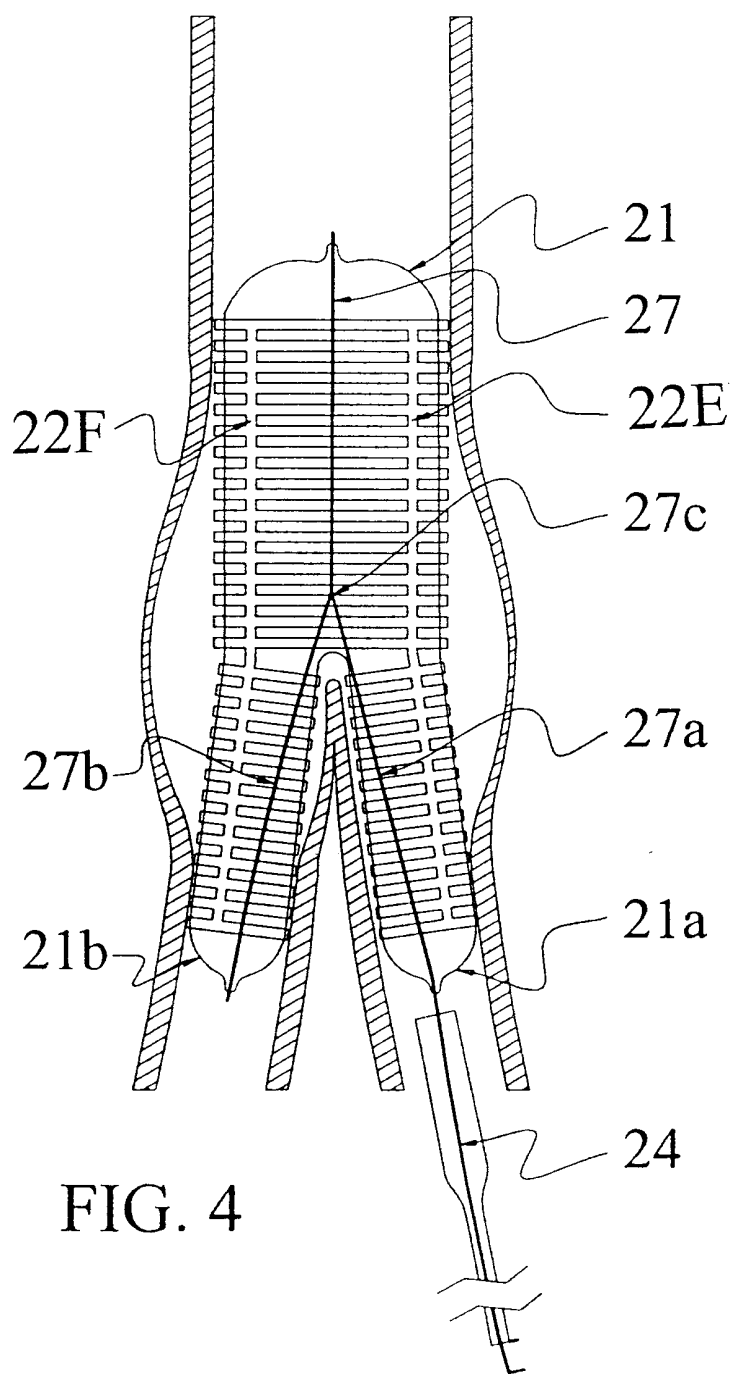

FIG. 4

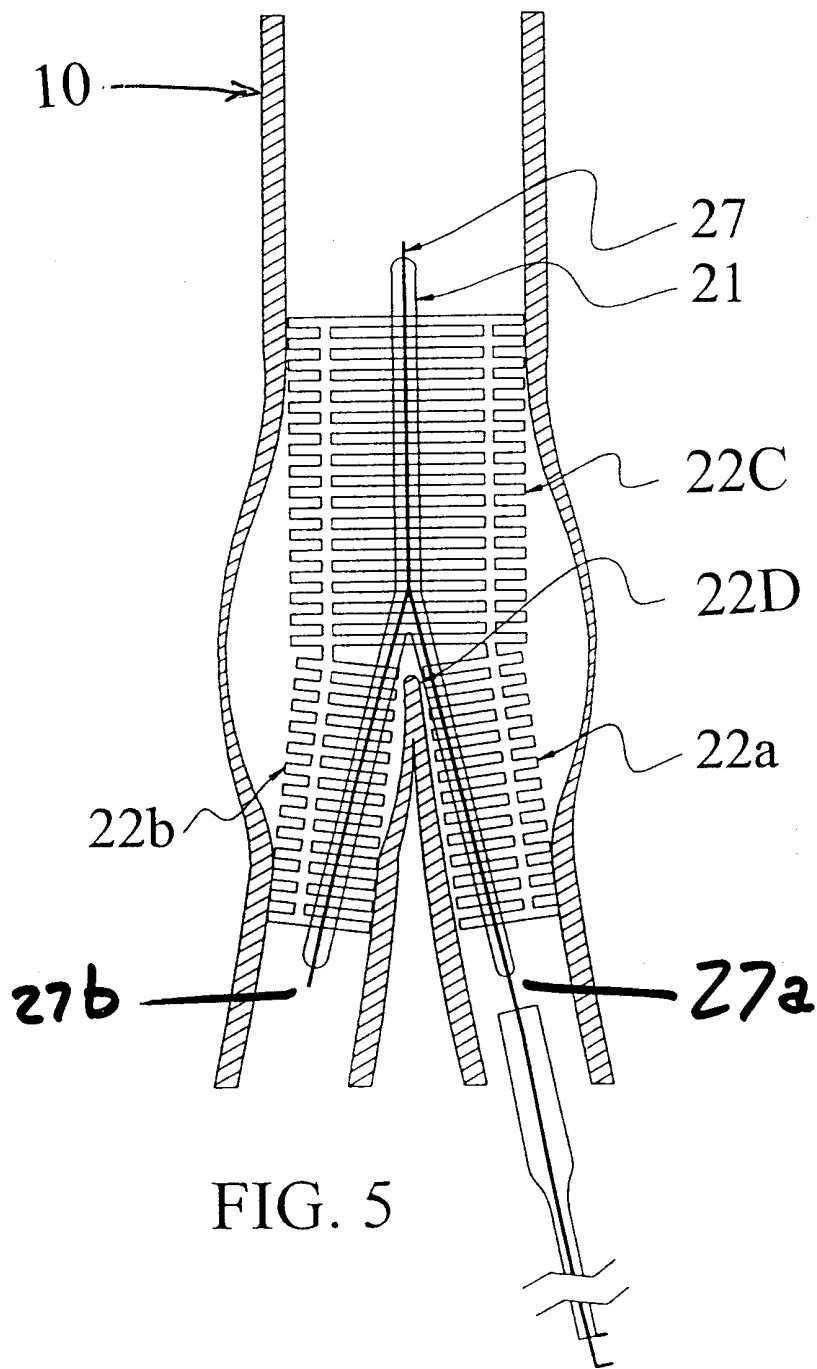

FIG. 5



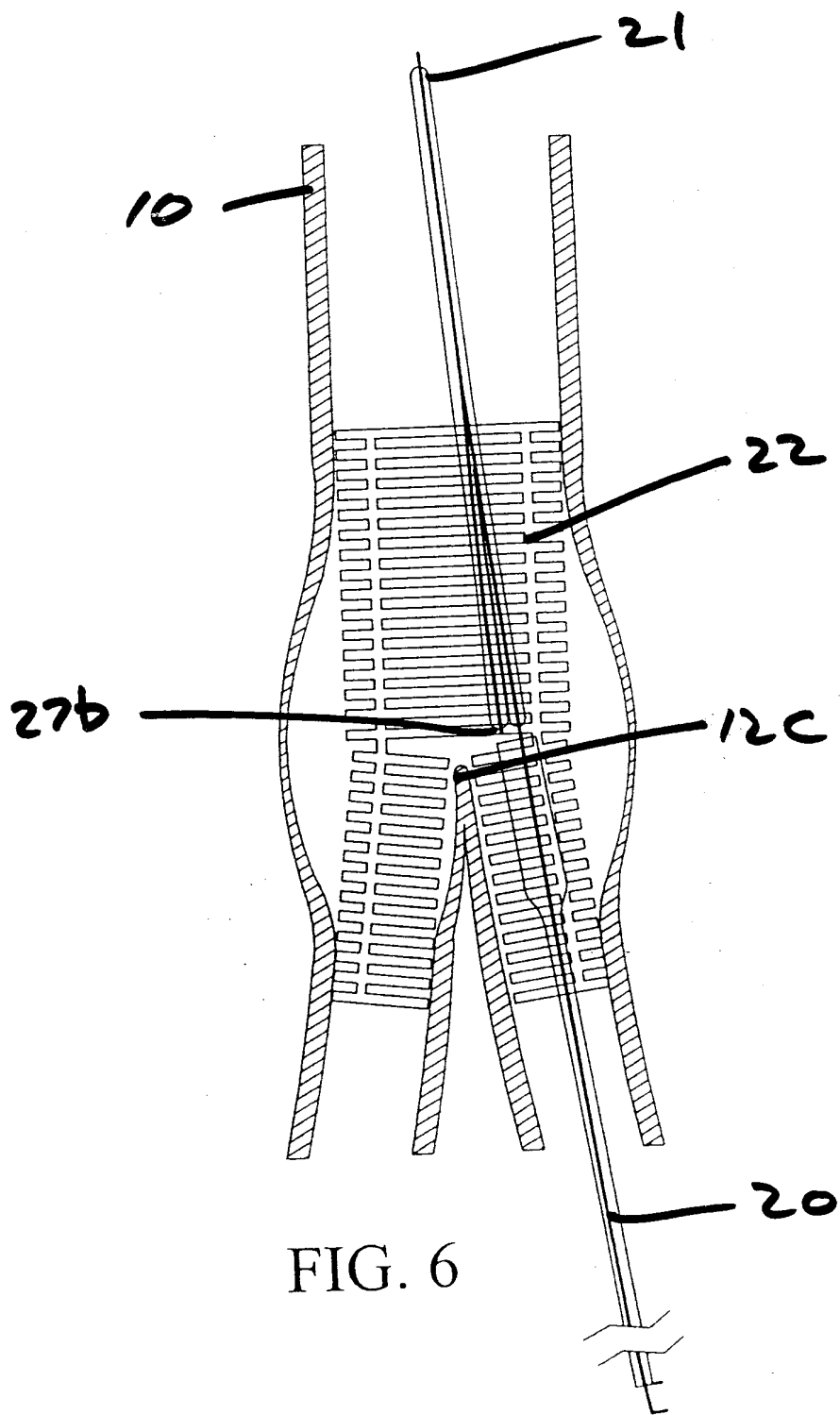

FIG. 6

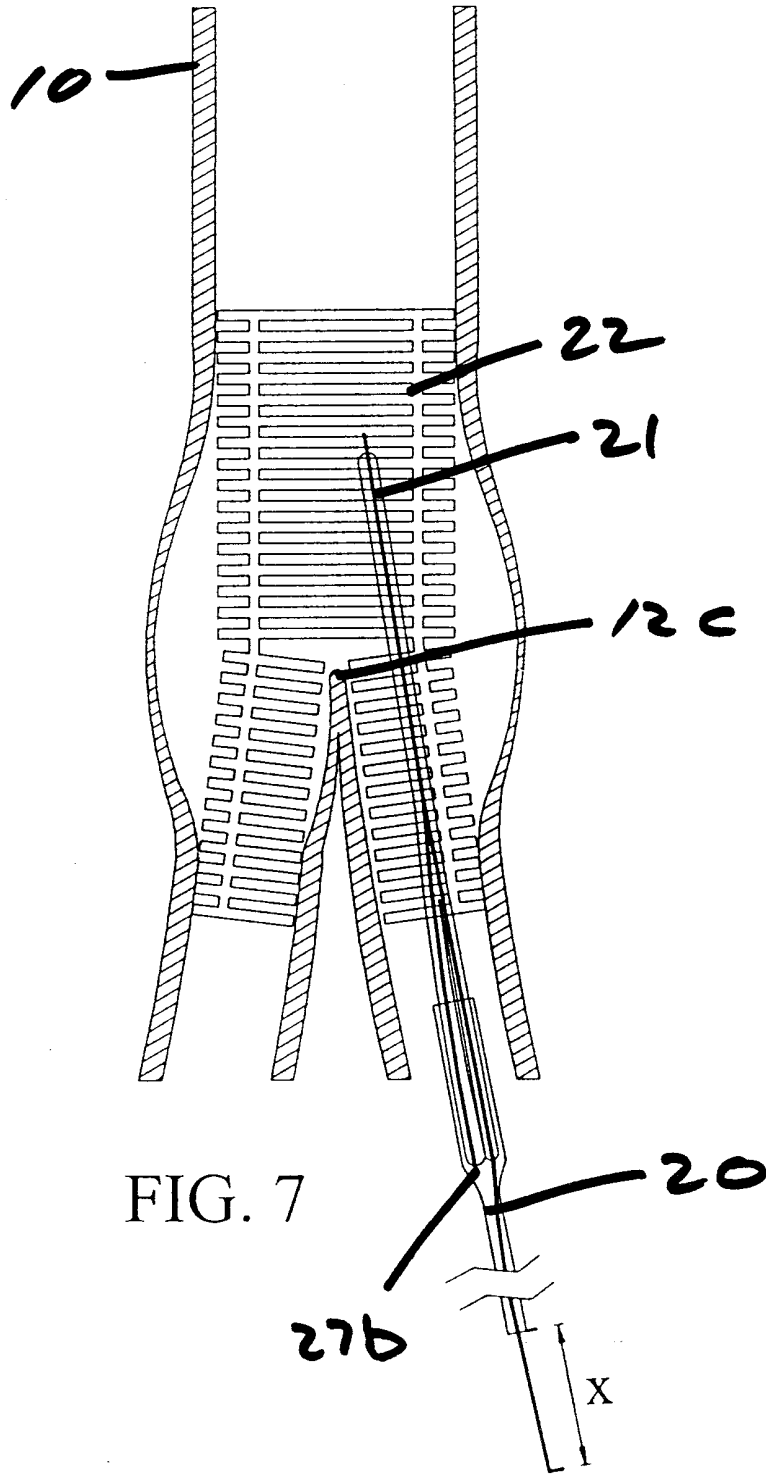

FIG. 7



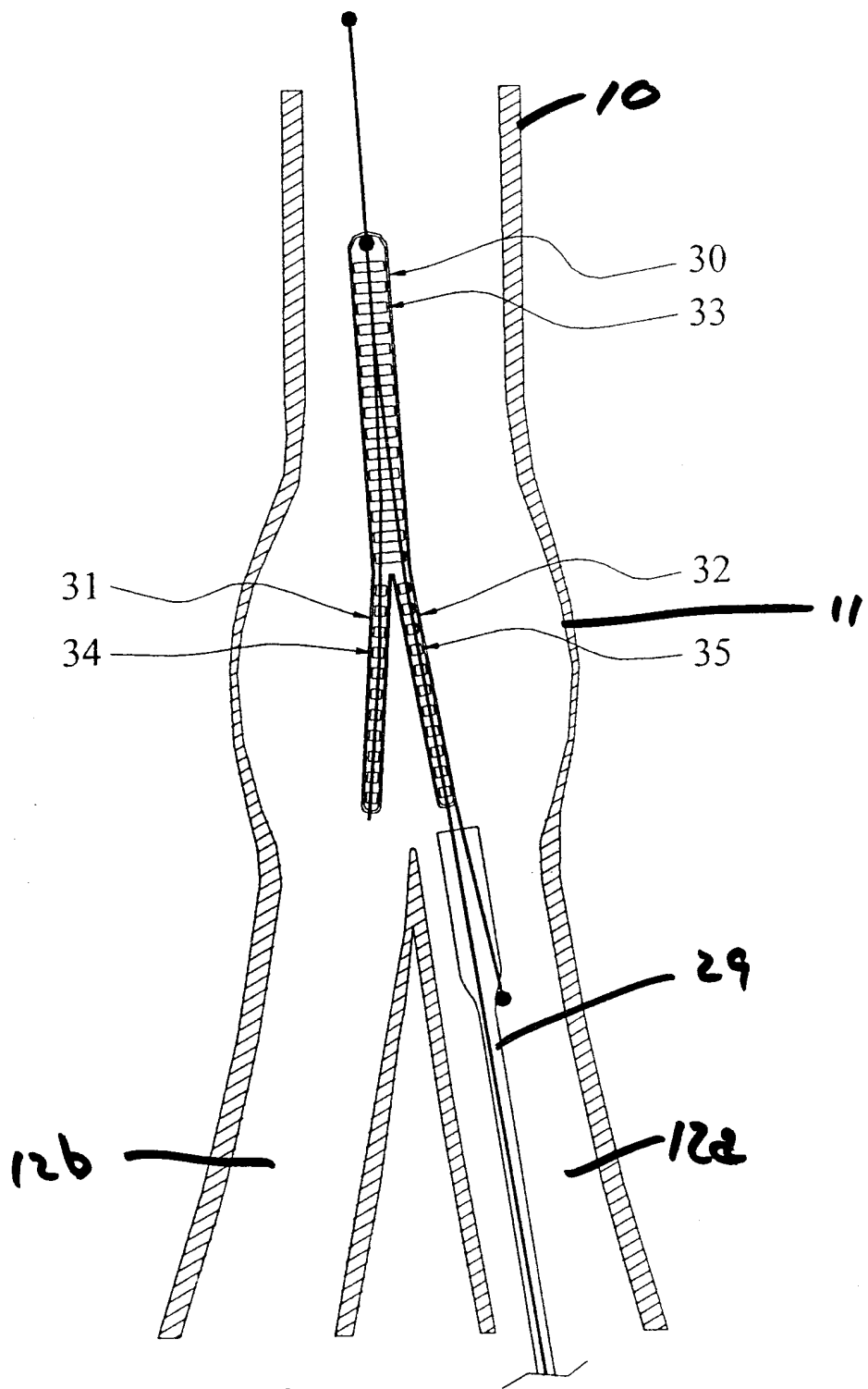

FIG. 9

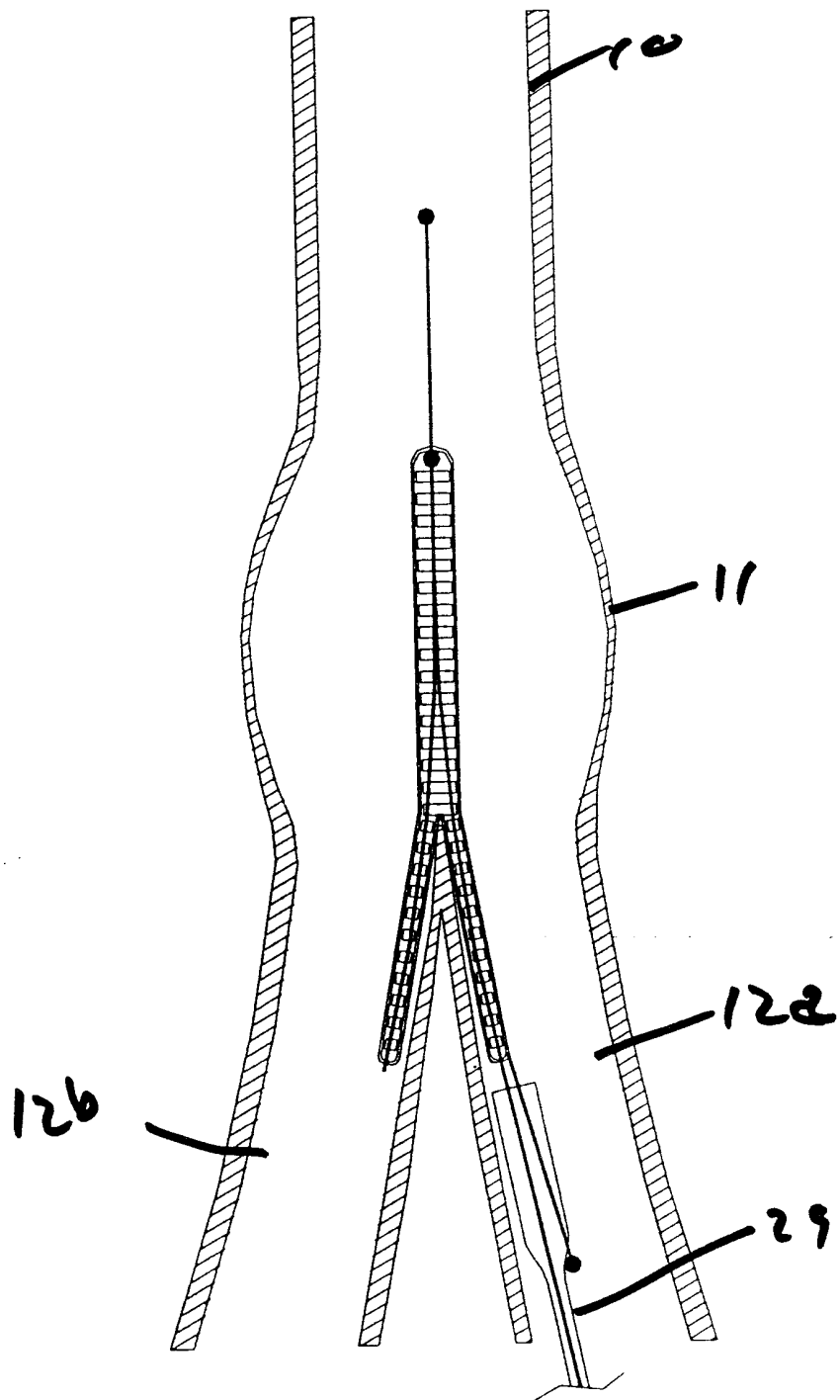

FIG. 10

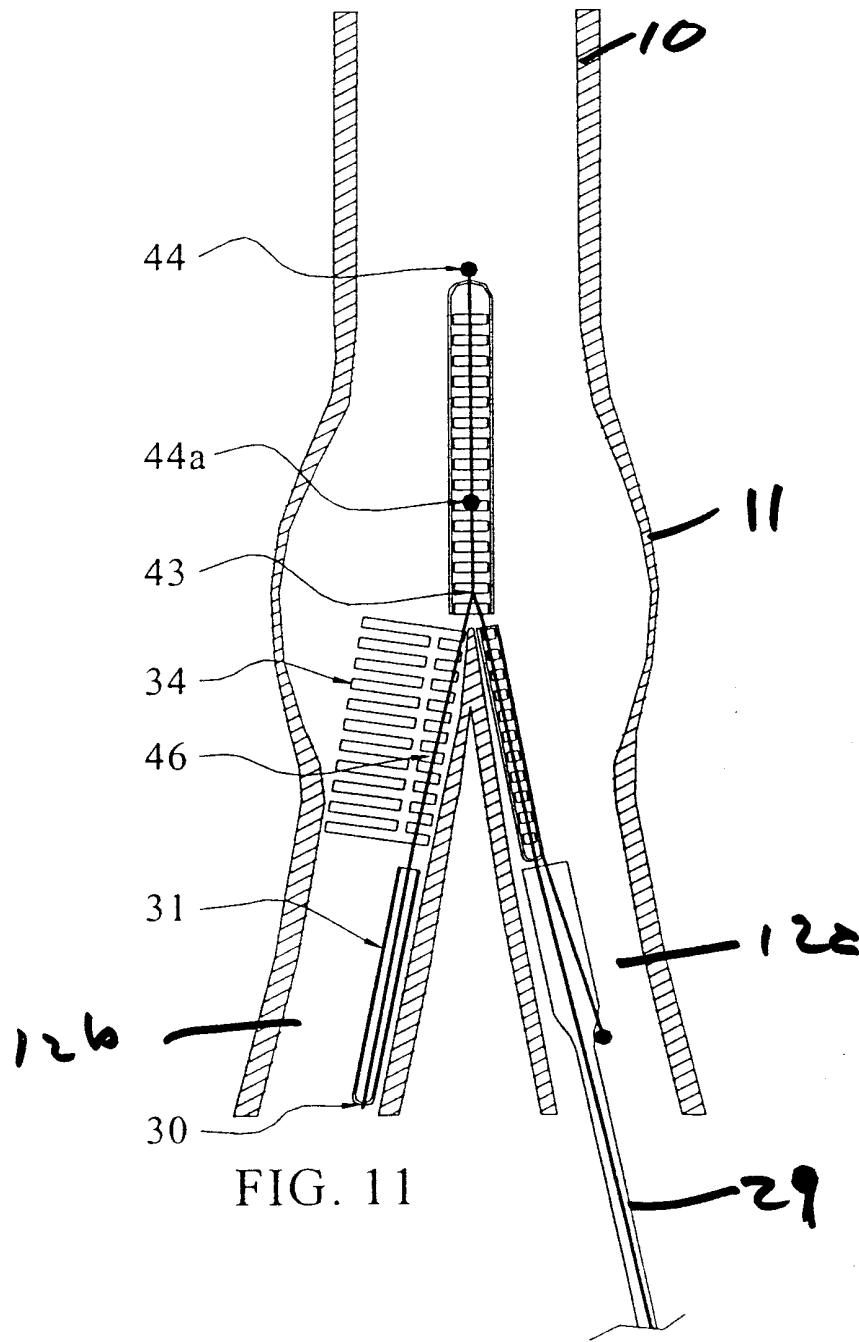

FIG. 11

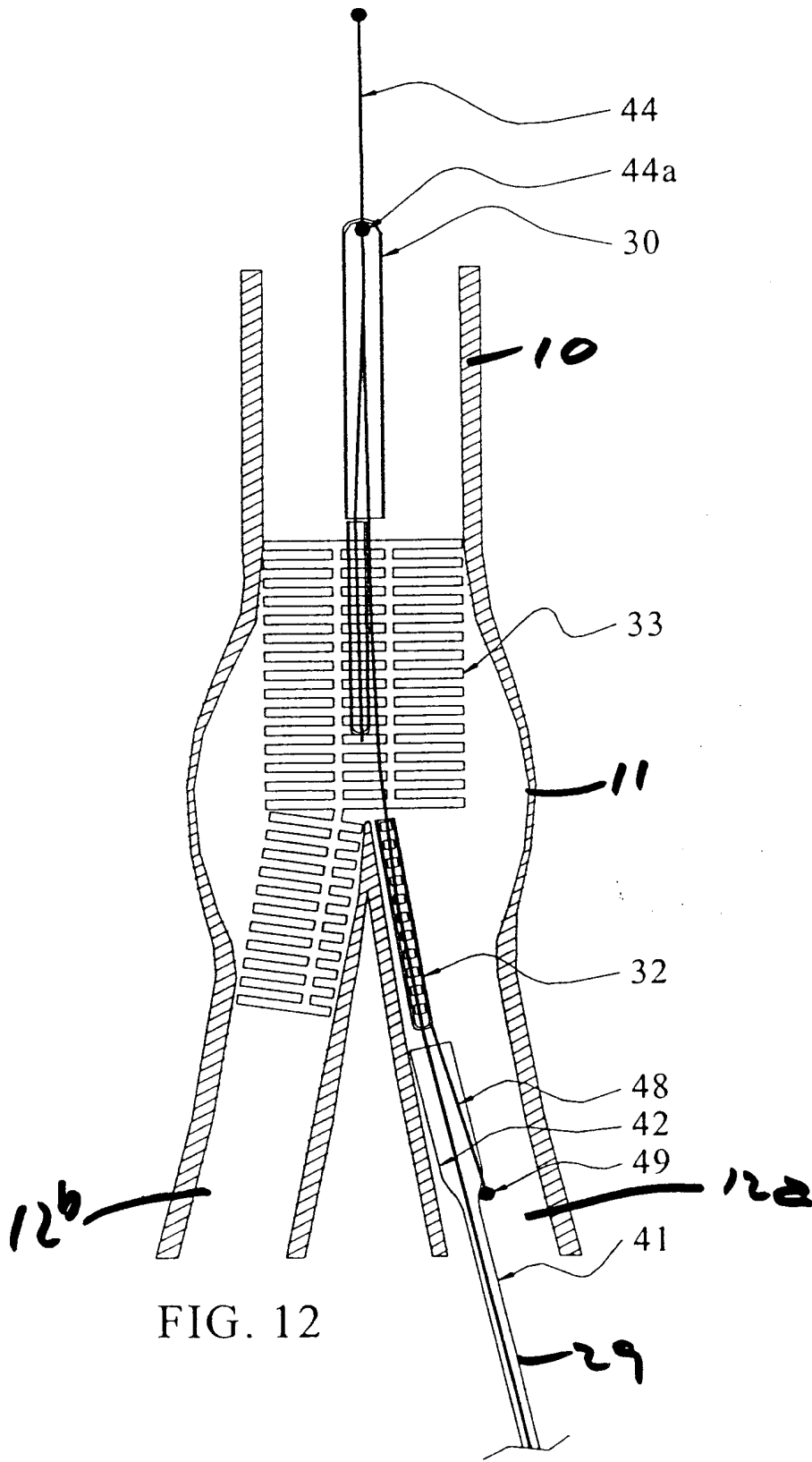

FIG. 12

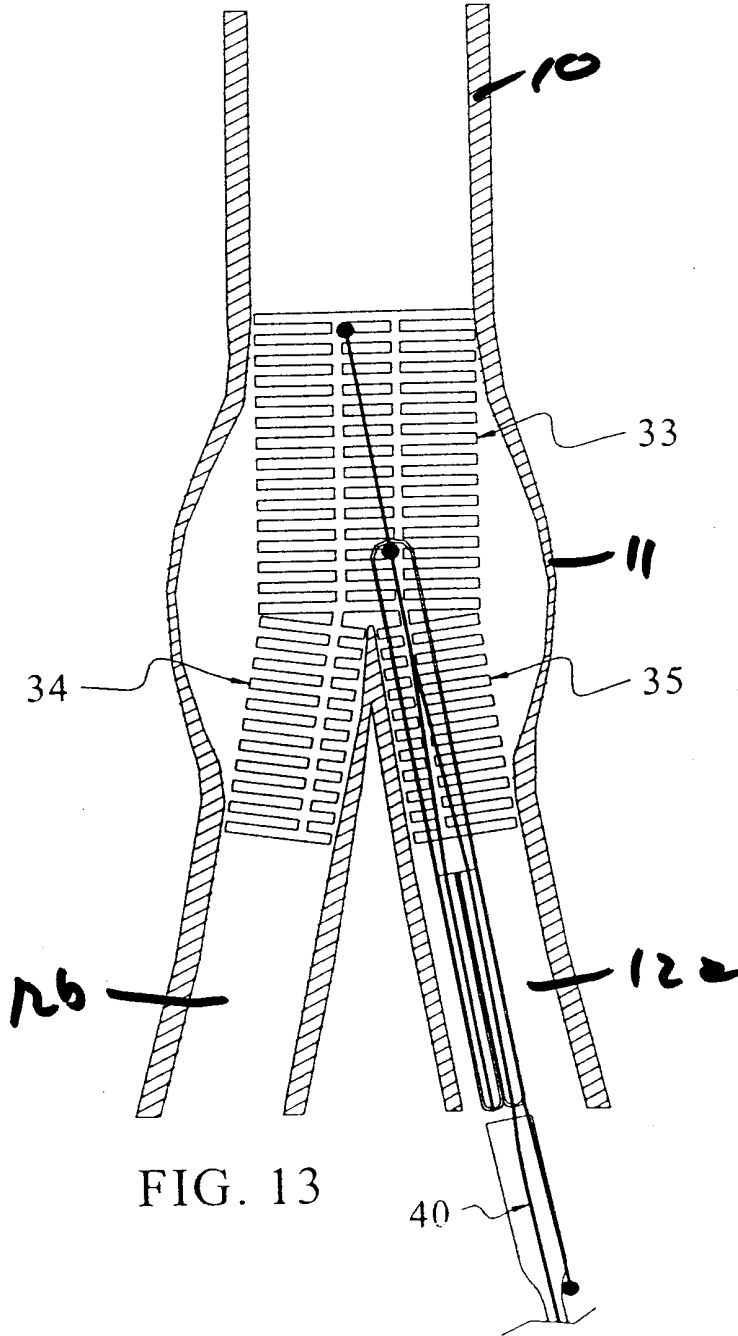

FIG. 13



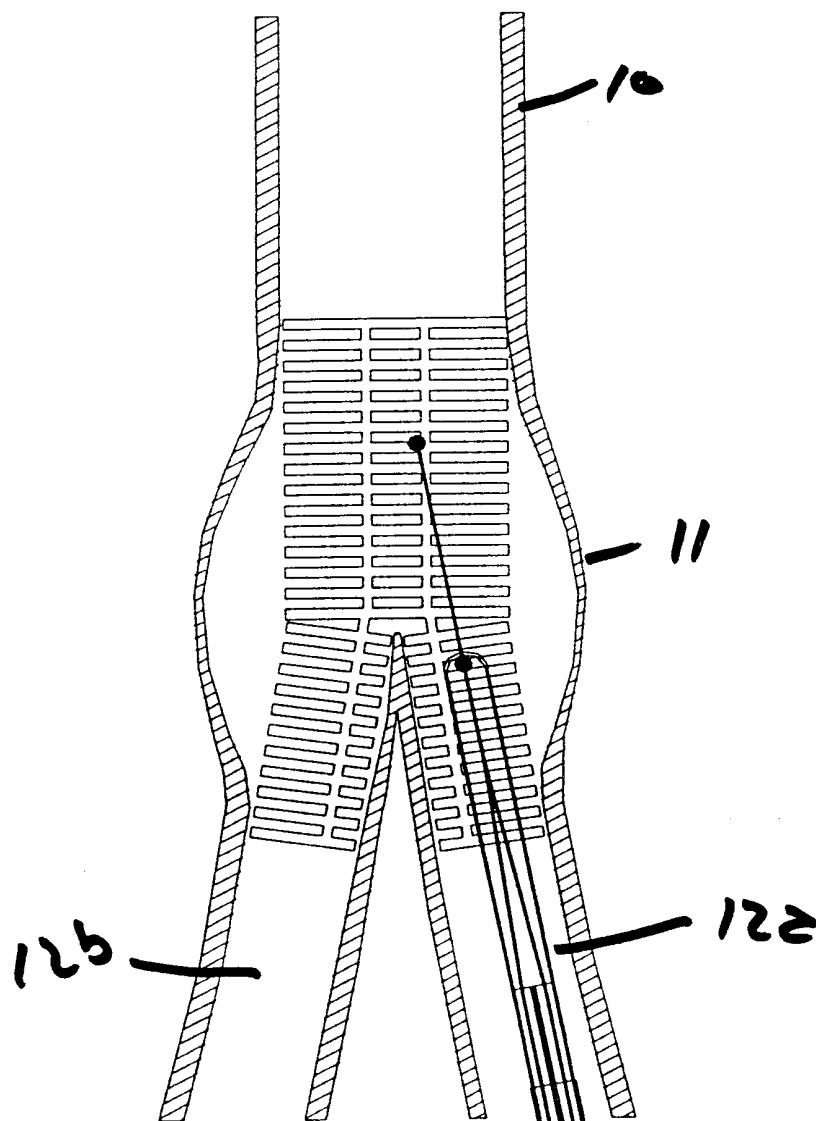
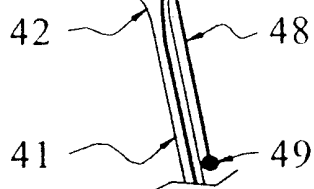

FIG. 14



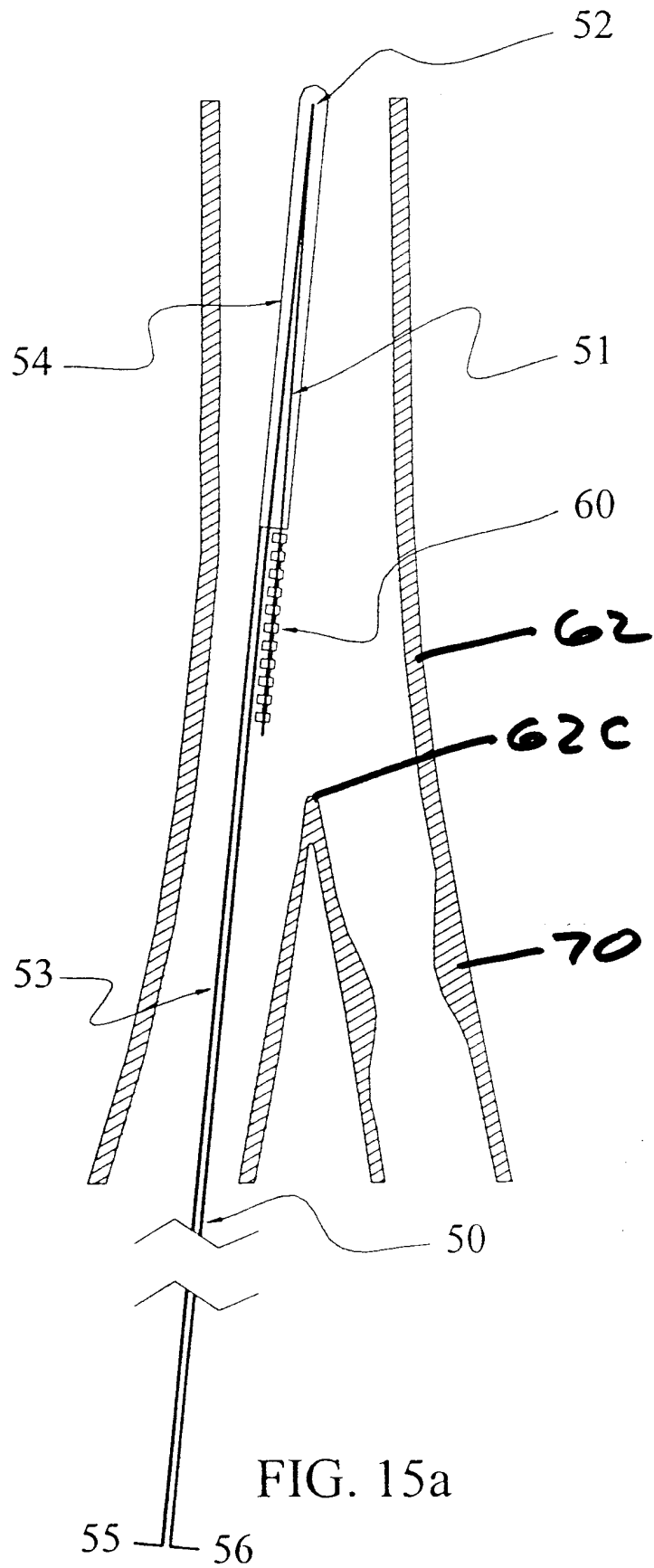

FIG. 15a

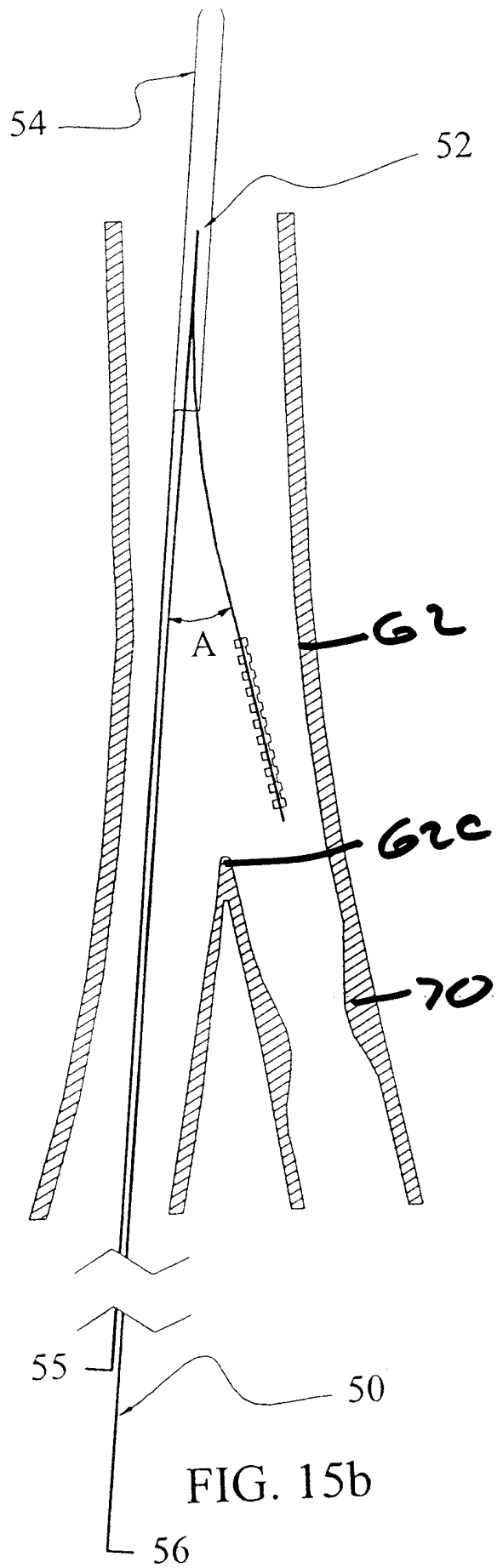
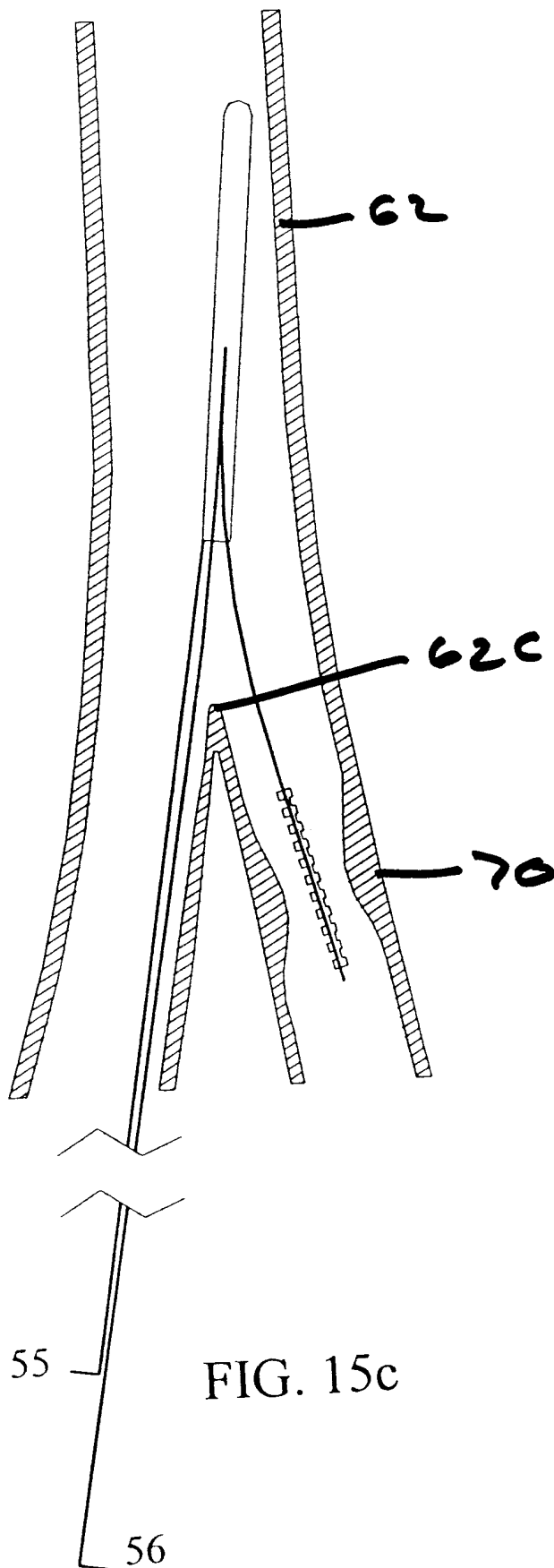
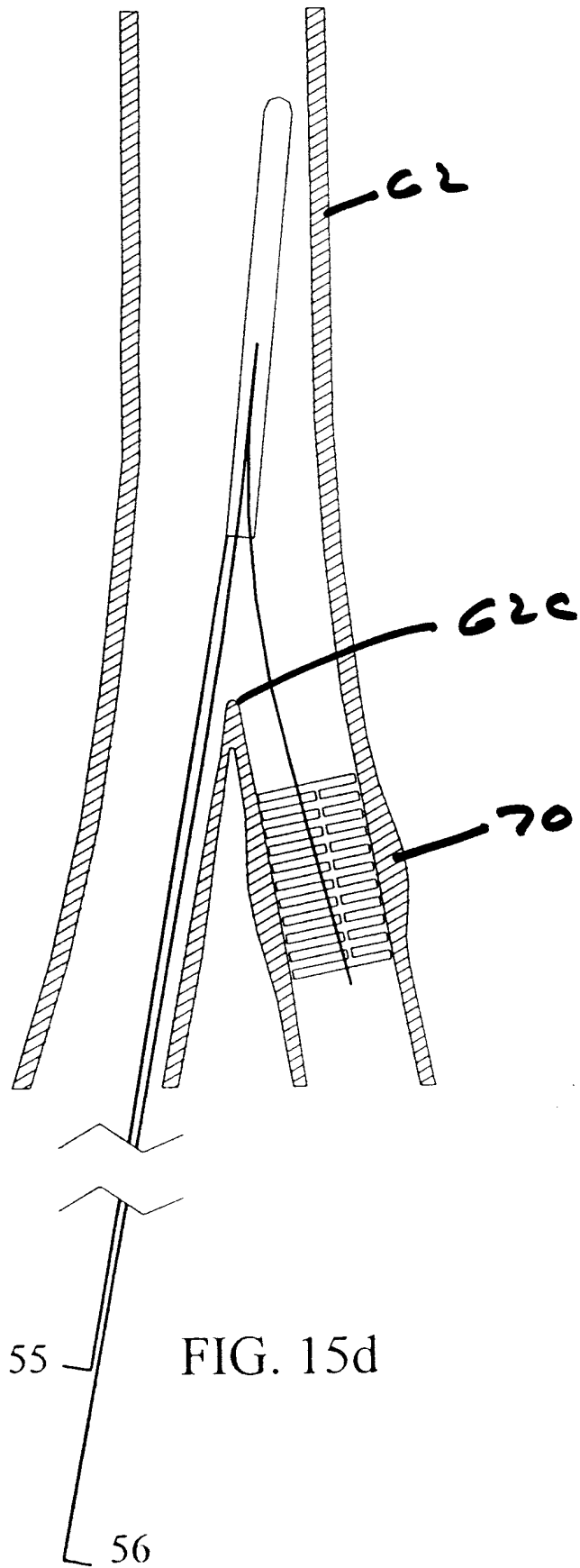

FIG. 15b





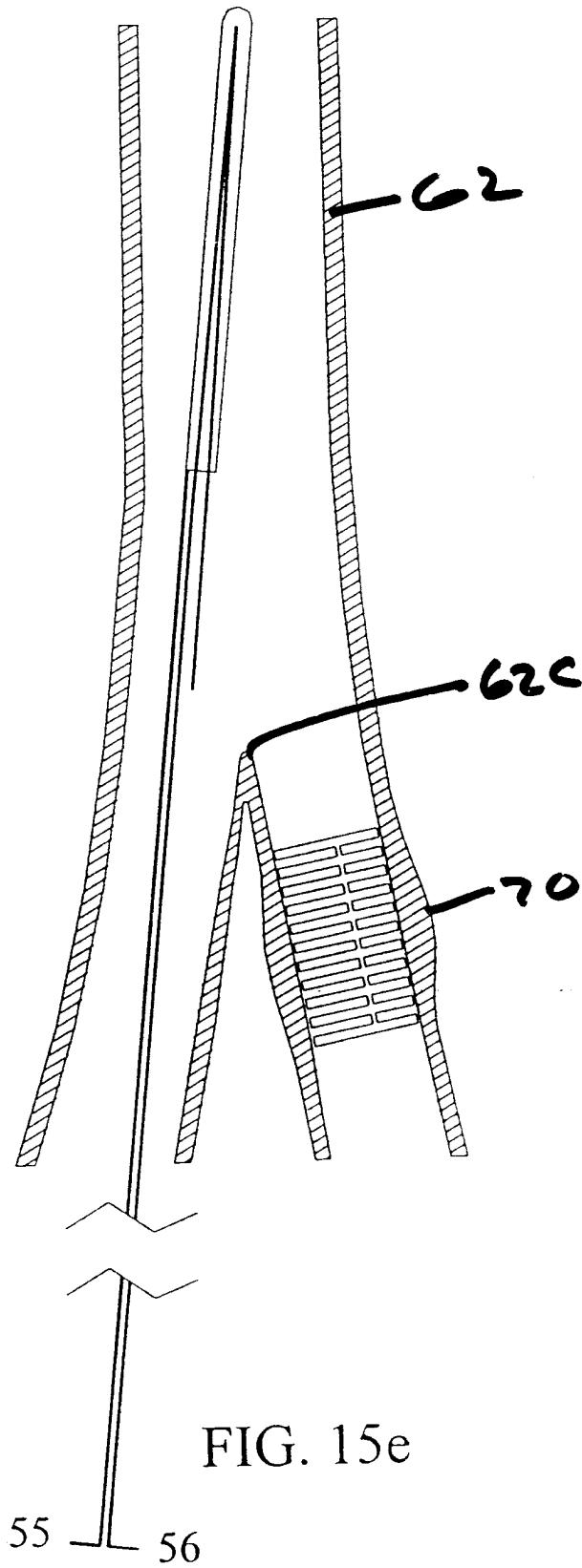

FIG. 15e

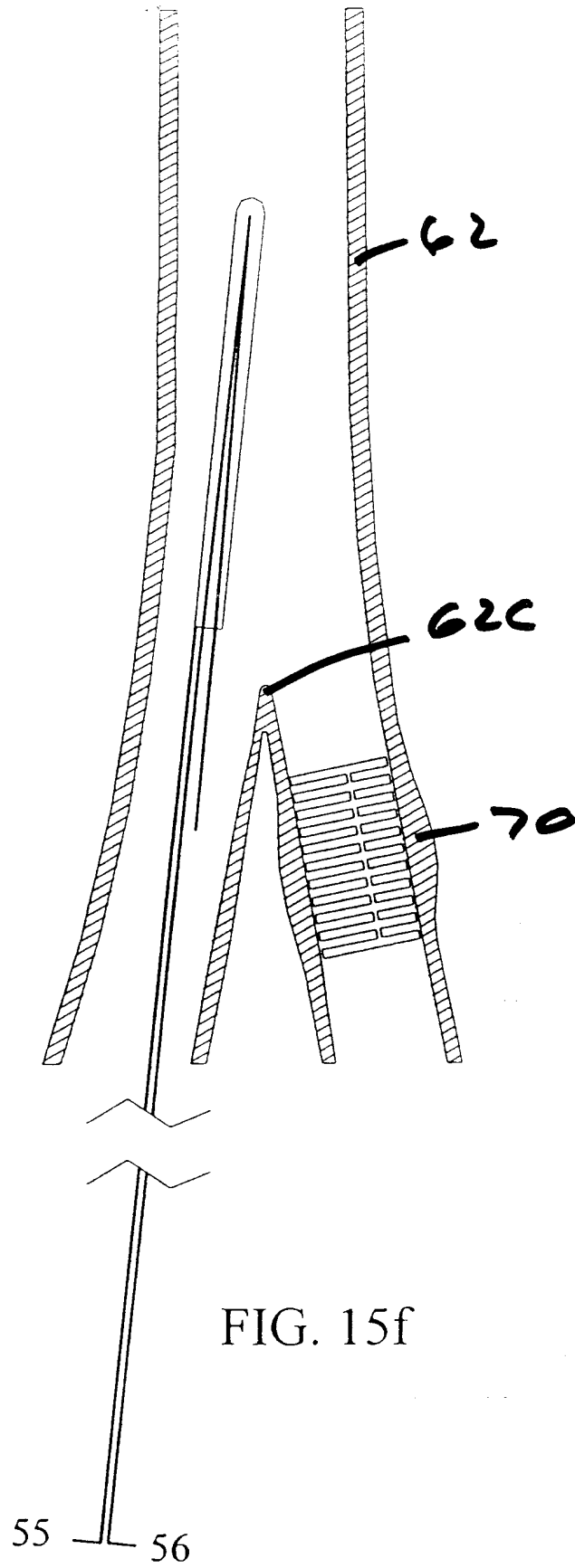
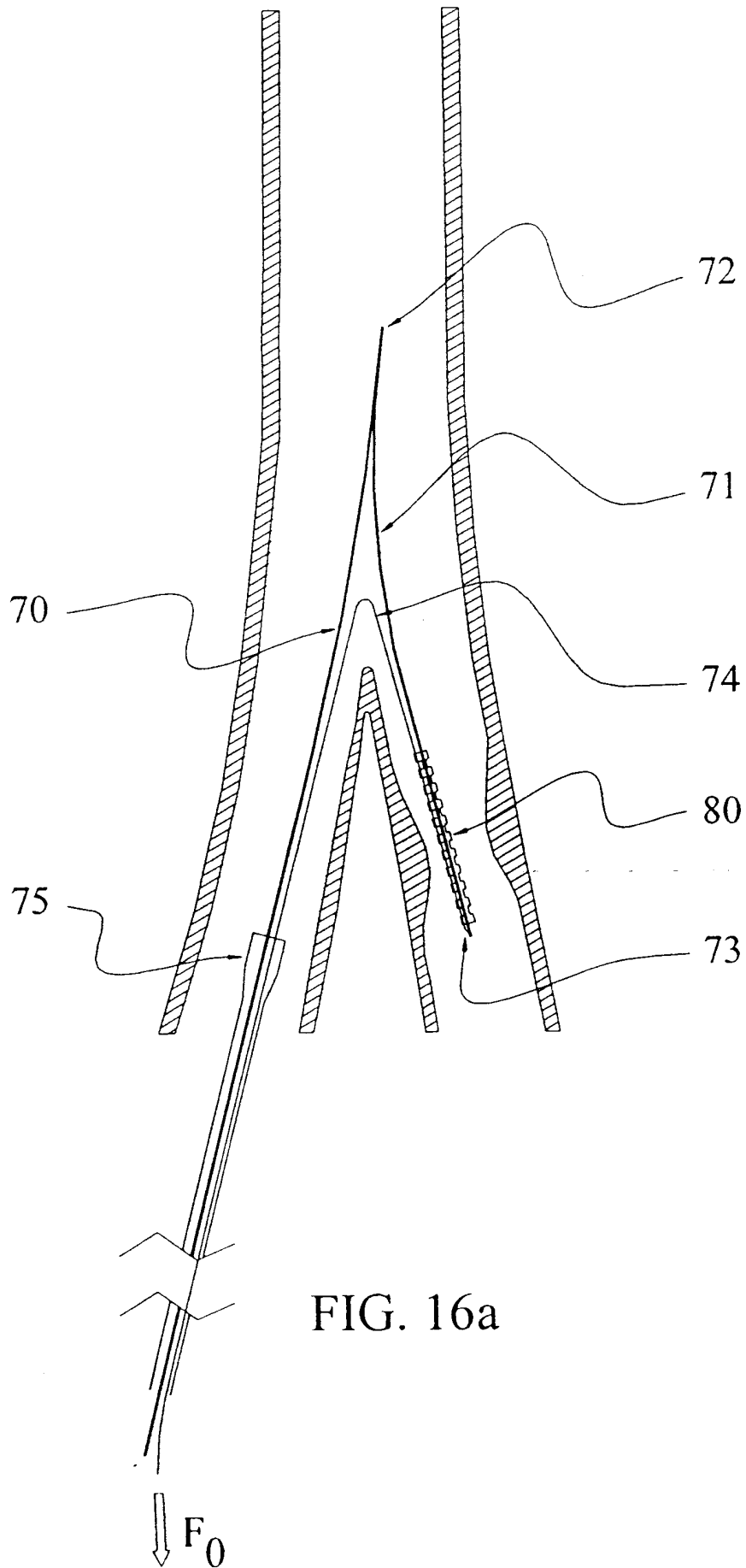

FIG. 15f





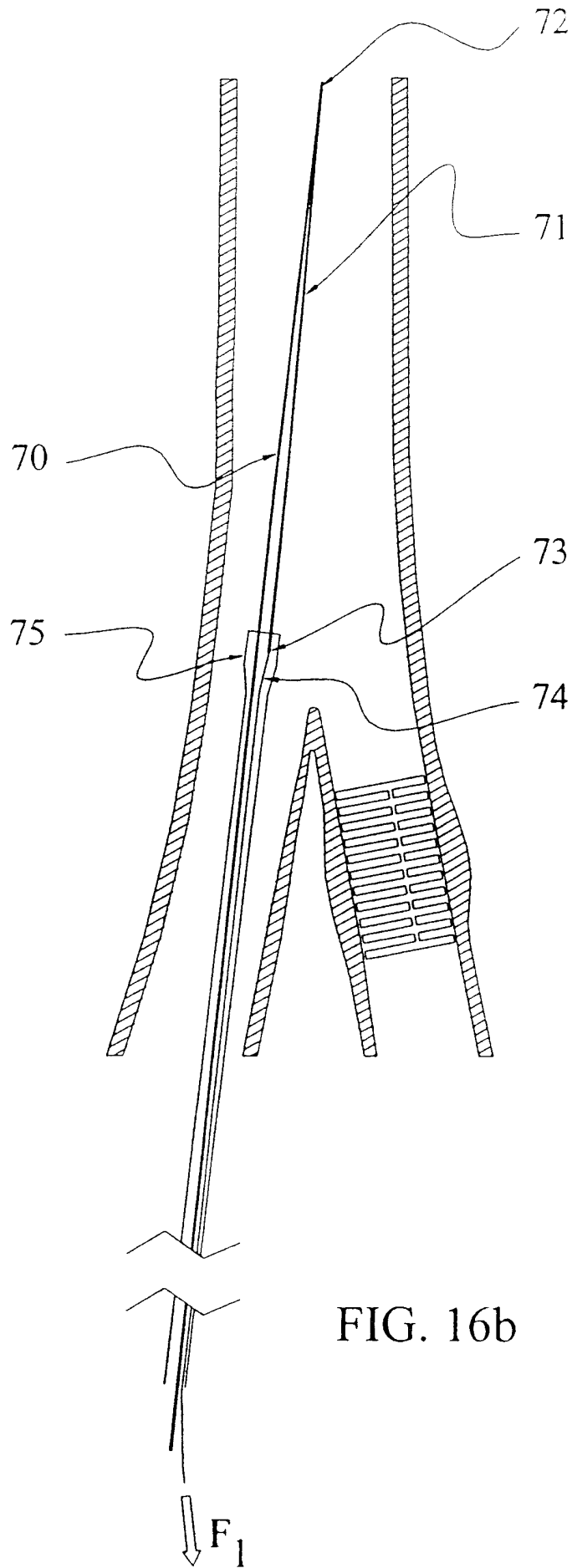

FIG. 16b

PATENT COOPERATION TREATY

PCT

DECLARATION OF NON-ESTABLISHMENT OF INTERNATIONAL SEARCH REPORT

(PCT Article 17(2)(a), Rules 13ter.1(c) and Rule 39)

Applicant's or agent's file reference BES 0007 PB	IMPORTANT DECLARATION	Date of mailing(day/month/year) 04/04/2001
International application No. PCT/IB 00/ 01831	International filing date(day/month/year) 17/11/2000	(Earliest) Priority date(day/month/year) 18/11/1999
International Patent Classification (IPC) or both national classification and IPC		A61F2/06
Applicant BESSELINK, Petrus		

This International Searching Authority hereby declares, according to Article 17(2)(a), that **no international search report will be established** on the international application for the reasons indicated below

1.  The subject matter of the international application relates to:
  - a.  scientific theories.
  - b.  mathematical theories
  - c.  plant varieties.
  - d.  animal varieties.
  - e.  essentially biological processes for the production of plants and animals, other than microbiological processes and the products of such processes.
  - f.  schemes, rules or methods of doing business.
  - g.  schemes, rules or methods of performing purely mental acts.
  - h.  schemes, rules or methods of playing games.
  - i.  methods for treatment of the human body by surgery or therapy.
  - j.  methods for treatment of the animal body by surgery or therapy.
  - k.  diagnostic methods practised on the human or animal body.
  - l.  mere presentations of information.
  - m.  computer programs for which this International Searching Authority is not equipped to search prior art.
  
2.  The failure of the following parts of the international application to comply with prescribed requirements prevents a meaningful search from being carried out:
 

<input type="checkbox"/> the description	<input checked="" type="checkbox"/> the claims	<input type="checkbox"/> the drawings
--	--	---------------------------------------
  
3.  The failure of the nucleotide and/or amino acid sequence listing to comply with the standard provided for in Annex C of the Administrative Instructions prevents a meaningful search from being carried out:
 

<input type="checkbox"/> the written form has not been furnished or does not comply with the standard.
<input type="checkbox"/> the computer readable form has not been furnished or does not comply with the standard.
  
4. Further comments: SEE FURTHER INFORMATION CONTINUED FROM PCT/ISA/203

Name and mailing address of the International Searching Authority  European Patent Office, P.B. 5818 Patentlaan 2 NL-2280 HV Rijswijk Tel. (+31-70) 340-2040, Tx. 31 651 epo nl, Fax: (+31-70) 340-3016	Authorized officer Nathalie Geisler
--	--

## FURTHER INFORMATION CONTINUED FROM PCT/ISA/ 203

A meaningful search is not possible on the basis of all claims because all claims are directed to - Method for treatment of the human or animal body by surgery - Rule 39.1(iv) PCT

The applicant's attention is drawn to the fact that claims relating to inventions in respect of which no international search report has been established need not be the subject of an international preliminary examination (Rule 66.1(e) PCT). The applicant is advised that the EPO policy when acting as an International Preliminary Examining Authority is normally not to carry out a preliminary examination on matter which has not been searched. This is the case irrespective of whether or not the claims are amended following receipt of the search report or during any Chapter II procedure. If the application proceeds into the regional phase before the EPO, the applicant is reminded that a search may be carried out during examination before the EPO (see EPO Guideline C-VI, 8.5), should the problems which led to the Article 17(2) declaration be overcome.