



- (51) International Patent Classification:
A46B 15/00 (2006.01) *A46B 5/00* (2006.01)
- (21) International Application Number:
PCT/IB2024/055446
- (22) International Filing Date:
04 June 2024 (04.06.2024)
- (25) Filing Language: English
- (26) Publication Language: English
- (30) Priority Data:
63/506,908 08 June 2023 (08.06.2023) US
- (71) Applicant: **HALEON US HOLDINGS LLC** [US/US];
251 Little Falls Drive, Wilmington, Delaware 19808 (US).
- (72) Inventor: **MUELLER, Wolf-Dieter**; c/o Haleon, Building
5, First Floor, The Heights, Weybridge Surrey KT13 0NY
(GB).
- (81) Designated States (*unless otherwise indicated, for every
kind of national protection available*): AE, AG, AL, AM,
AO, AT, AU, AZ, BA, BB, BG, BH, BN, BR, BW, BY, BZ,
CA, CH, CL, CN, CO, CR, CU, CV, CZ, DE, DJ, DK, DM,
DO, DZ, EC, EE, EG, ES, FI, GB, GD, GE, GH, GM, GT,
HN, HR, HU, ID, IL, IN, IQ, IR, IS, IT, JM, JO, JP, KE, KG,
KH, KN, KP, KR, KW, KZ, LA, LC, LK, LR, LS, LU, LY,

MA, MD, MG, MK, MN, MU, MW, MX, MY, MZ, NA,
NG, NI, NO, NZ, OM, PA, PE, PG, PH, PL, PT, QA, RO,
RS, RU, RW, SA, SC, SD, SE, SG, SK, SL, ST, SV, SY, TH,
TJ, TM, TN, TR, TT, TZ, UA, UG, US, UZ, VC, VN, WS,
ZA, ZM, ZW.

- (84) Designated States (*unless otherwise indicated, for every
kind of regional protection available*): ARIPO (BW, CV,
GH, GM, KE, LR, LS, MW, MZ, NA, RW, SC, SD, SL, ST,
SZ, TZ, UG, ZM, ZW), Eurasian (AM, AZ, BY, KG, KZ,
RU, TJ, TM), European (AL, AT, BE, BG, CH, CY, CZ,
DE, DK, EE, ES, FI, FR, GB, GR, HR, HU, IE, IS, IT, LT,
LU, LV, MC, ME, MK, MT, NL, NO, PL, PT, RO, RS, SE,
SI, SK, SM, TR), OAPI (BF, BJ, CF, CG, CI, CM, GA, GN,
GQ, GW, KM, ML, MR, NE, SN, TD, TG).

Declarations under Rule 4.17:

- *as to applicant's entitlement to apply for and be granted a patent (Rule 4.17(ii))*
- *as to the applicant's entitlement to claim the priority of the earlier application (Rule 4.17(iii))*

Published:

- *with international search report (Art. 21(3))*
- *in black and white; the international application as filed contained color or greyscale and is available for download from PATENTSCOPE*

(54) Title: FEEDBACK ENABLED ORAL CARE DEVICE

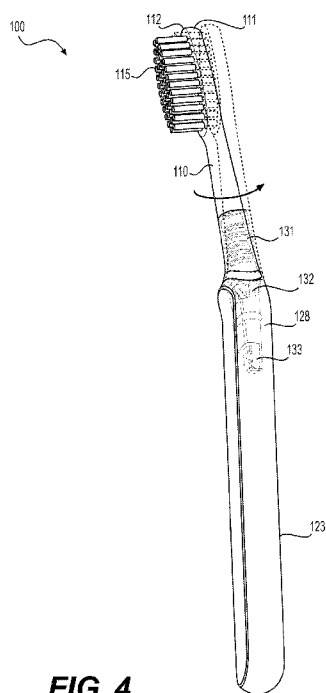

FIG. 4

(57) Abstract: An oral care device comprising: a brush portion including a brush head having a plurality of bristles attached thereto; and a handle portion including a neck, a feedback mechanism, and a base, wherein the feedback mechanism includes a spring portion and a hammer; and wherein the feedback mechanism is activated and provides feedback when force exceeding a threshold is applied to a first surface of the brush head.



FEEDBACK ENABLED ORAL CARE DEVICE

Field of the Invention:

[0001] The present invention relates to an oral care device with a feedback mechanism to prevent damage to the teeth and gums during brushing by alerting the user when excessive force is being used on the teeth.

Background of the Invention:

[0002] Good dental hygiene and health includes regularly brushing teeth using a toothbrush. Manual toothbrushes are commonly used for this purpose; unfortunately, individuals often improperly use manual toothbrushes as there is no reliable way to safely control the pressure that is applied to the teeth while cleaning. Often, individuals do not realize that they are using too much pressure to clean their teeth, which can cause mechanical wear and damage. This can lead to several health problems including cervical abrasions, gingival recession, tooth sensitivity, damage to the enamel, and irritation to gums. Thus, there is a need for a toothbrush with a feedback mechanism to alert the user when too much pressure is being used to brush their teeth.

Summary

[0003] Aspects of the invention are directed to an oral care device comprising; a brush portion including a brush head having a plurality of bristles attached thereto, and a handle portion including a neck, a feedback mechanism, and a base, wherein the feedback mechanism includes a spring portion and a hammer, and wherein the feedback mechanism is activated and provides a feedback when force exceeding a threshold is applied to a first surface of the brush head.

[0004] Aspects of the invention are directed to an oral care device wherein the feedback mechanism provides an audible feedback when activated. Aspects of the invention are directed to an oral care device wherein the feedback mechanism provides a haptic feedback when activated.

[0005] Aspects of the invention are directed to an oral care device, wherein the head of the device is removable.

[0006] Aspects of the invention are directed to a handle for an oral care device comprising; a neck, a feedback mechanism, and a base, wherein the feedback mechanism includes a spring portion and a hammer, and wherein the feedback mechanism is activated

and provides feedback when force exceeding a threshold is applied to a first surface of the brush head.

Description of Figures

[0007] Figure 1 illustrates a perspective view of an oral care device according to an embodiment;

[0008] Figure 2 illustrates a perspective view of the oral care device with a head portion removed according to an embodiment;

[0009] Figure 3 illustrates an exploded view of the oral care device according to an embodiment;

[0010] Figure 4 illustrates the operation of the oral care device according to an embodiment; and

[0011] Figure 5 illustrates a cross-sectional view of a feedback mechanism of the oral care device according to an embodiment.

Detailed Description

[0012] Aspects of the present invention are directed to a feedback enabled oral care device which helps prevent mechanical wear and damage to the teeth by alerting the user when excessive force is being used to clean the teeth. In an embodiment, the oral care device is a manual or electric toothbrush. In a preferred embodiment, the oral care device is a manual toothbrush.

[0013] Figures 1 and 2 illustrate a perspective view of the oral care device 100 according to an embodiment. The oral care device 100 includes a brush portion 110, and a handle body 120. The brush portion 110 extends from the handle body 120 and includes a brush head 111 disposed on a top end in the long axis direction. The handle body 120 further includes a neck 121, a feedback mechanism, and a base portion 123. In an embodiment, the feedback mechanism is embedded within an interior cavity of the handle body 120. In an embodiment, the handle body 120 may include a grip portion 124 made from a soft material provided over at least a portion of the feedback mechanism. In an embodiment, the material of the grip portion is styrene ethylene butylen, styrene polymer, thermoplastic elastomer, or a combination thereof.

[0014] In an embodiment, the feedback mechanism may provide a haptic or tactile feedback and/or audible feedback perceivable to the user. In an embodiment, the feedback is a vibration, a click sound, or a combination thereof.

[0015] In an embodiment, the brush head 111 includes a front surface 112 and a back surface 113 which are opposite to each other. In an embodiment, the front surface 112 is the brushing surface and may include bristle receiving holes. Tufts or bristles 115 for brushing the surface of the teeth may be inserted into the bristle receiving holes by any means known in the art. The back surface 113 may include a tongue cleaning element 114 that may be used to clean the tongue. The tongue cleaning element 114 may be a rough or textured surface. In another embodiment, the front surface 112 includes a plurality of bristles or tufts 115, and the back surface 113 is smooth.

[0016] In an embodiment, the brush portion 110 and the tongue cleaning element 114 are made of the same material. In an embodiment, the material may be a hard plastic such as, polypropylene (PP) or polyethylene (PE), high-density polyethylene (HDPE), low-density polyethylene (LDPE), polyethylene terephthalate (PET), polyethylene terephthalate (PETA), glycol-modified polyethylene terephthalate (PETG), or polybutadiene terephthalate (PBT). In an embodiment, the material of the brush portion 110 and the tongue cleaning element 114 is PP.

[0017] In an embodiment, the neck 121 is flexible and allows the brush portion 110 to move and pivot in response to force applied to the front surface 112. When a force applied by the user in a first direction orthogonal to the front surface 112 exceeds a threshold value, the brush portion 110 moves in the first direction and the feedback mechanism is activated to provide feedback to the user to alert the user that excessive force is being used. Once the force applied decreases and is within an appropriate range below the threshold value, the brush portion 110 returns to the initial position, the feedback mechanism is deactivated, and the oral care device 100 is ready for use again.

[0018] Figure 2 is an exploded view illustrating the head portion 110 removed from the handle body 120 according to an embodiment. The head portion 110 of the oral care device 100 is removable and can be replaced allowing the user to replace the head portion 110 once the bristles 115 have been damaged or worn down without the need to replace the entire device. This also allows the oral care device 100 to be shared among users. This provides cost savings to the user and reduces waste.

[0019] Figure 3 is an exploded view of the oral care device 100 according to an embodiment. The brush head 110 and feedback mechanism 130 are connected via a connector 125. A bottom of the connector 125 fits into a flexible portion 131 of the feedback mechanism 130 and a bottom of the brush head 110 is removably attached to a top of the connector 125. The brush head 110 may be removed and replaced by a user as needed. The

feedback mechanism 130 includes the flexible portion 131, a spring portion 132, and a hammer 133. When activated, the spring portion 132 and the hammer 133 drive the feedback mechanism 130 by enabling the hammer 133 to provide the feedback. A cover 126 may be included that covers the spring portion 132. In an embodiment, the spring portion 132 includes two arms. In an embodiment, the spring portion has a height between about 1.5mm and about 3.0mm. In an embodiment, the height of the spring portion is about 2.4mm. In an embodiment, the spring portion has a wide between about 2.0mm and about 3.5mm. In an embodiment, the width of the spring portion is about 2.9mm.

[0020] In an embodiment, the hammer 133 may have a tapered shaped such that it is wider at a base 133a and thinner as it extends down towards a tip 133b. In an embodiment, the hammer has a thickness between about 2.0mm and about 3.5mm at the base 133a and between about 1.0mm and about 2.0mm at the tip 133b. In an embodiment, the hammer has a wide of about 2.8mm at the base 133a about 1.5mm at the tip 133b.

[0021] A top end of an inner handle 127 includes the cavity 128 into which at least portion of the feedback mechanism 130 extends. In an embodiment, the spring portion 132 and the hammer 133 extends into the cavity 128 of the inner handle portion 127. In an embodiment, the grip portion 124 is provided on the outer surface of the inner handle 127. In an embodiment, the grip portion 124 is made of a soft material that aids the user in gripping the toothbrush handle comfortably without slipping. In an embodiment, at least a portion of the feedback mechanism 130 is provided under the grip portion 124 where a user would typically hold the oral care device 100 so that the user can readily sense the feedback. The base portion 123 is provided over a bottom portion of the inner handle 127.

[0022] The feedback mechanism 130 and the base portion 123 of the handle body are made from a hard plastic such as, PP, PE, HDPE, LDPE, PET, PETA, PETG, PBT. In an embodiment, the material of the feedback mechanism 130 and the base portion 123 is PP. In an embodiment, no metal is included in the oral care device 100 and the oral care device 100 is free of any metal.

[0023] Figure 4 illustrates the operation of the oral care device 100 according to an embodiment. In an initial position, the brush head 110 is in the initial position and the feedback mechanism 130 is not activated. The hammer 133 is provided in the initial position in the cavity 128 of the inner handle, whereby the hammer 133 rests on a bottom surface of the cavity 128. The bottom surface of the cavity is a ramp such that the hammer 133 is pre-loaded in the initial position. The spring portion 132 is in an initial position.

[0024] When a force above the threshold value is applied to the toothbrush head 110, for example by brushing the teeth with too much force, the spring portion 132 allows the head portion 110 to move in the first direction (indicated by the arrow) orthogonal to the first surface 112 into an extended position. In the extended position, the hammer 133 moves into the activated state by the deformation of the spring portion 132 and abuts a top surface of the cavity 128. The interaction between the hammer 133 and the top surface of the cavity 128 creates the feedback for the user that too much force is being used. Once the force is decreased and below the threshold value, the spring portion 132 snaps back and the brush head 110 and the hammer 133 return to the initial position, and the oral care device 100 is ready for use again. In an embodiment, the threshold value is force between about 2.5 newtons and about 3.5 newtons. In another embodiment, the threshold value is force greater than about 3.5 newtons.

[0025] In an embodiment, a combination of the tension of the spring portion 132 as well as the tension of the pre-loaded hammer 133 is utilized to create the feedback. Force above the threshold value is required to overcome the tension or stiffness in the spring portion 132 and the hammer 133. In an embodiment, the hammer 133 is deflected sideways to overcome the ramped surface of the cavity 128 and abut the top surface of the cavity 128 to create the feedback. The feedback mechanism 300 is brought back to the initial state by the spring portion 132. The relative stiffness or tension of the spring portion 132 and the hammer 133 may be adjusted such that a majority of the force to create the feedback comes from either the spring portion 132, the hammer 133, or a combination thereof. The stiffness or tension of the spring portion 132 and the hammer 133 may be adjusted to adjust the threshold force required to create the feedback.

[0026] Figure 5 illustrates a cross-sectional view of the feedback mechanism 130. In the initial stage as shown in figure 5A, the hammer 133 is provided on the bottom surface 128a of the cavity 128 of the inner handle 127. The bottom surface 128a of the cavity 128 is a ramp having an angle of about 55 degrees, thereby the hammer 133 is preloaded with energy to create feedback of sufficient impact when activated. When the hammer 133 is inserted into the cavity during manufacturing of the oral care device 100, the shape of the hammer 133 and the ramp of the cavity 128 causes the hammer 133 to be preloaded, improving the feedback mechanism's reliability and robustness. In an embodiment, the hammer 133 is preloaded to one side of the cavity 128.

[0027] When the feedback mechanism 130 is activated as shown in Figure 5B, the spring portion 132 flexes in the first direction which moves the hammer 133 into the

activated stage in which it abuts a surface of the cavity 128, providing the feedback. In an embodiment, the hammer 133 abuts the top surface 128b of the cavity 128. When force is applied to the first surface 112 of the brush head 111, force builds up on the ramp until sufficient elastic potential builds up, i.e., when the force exceeds the threshold value, causing the hammer 133 to strike or abut the top surface 128b of the cavity 128. In an embodiment, the hammer 133 is deflected sideways to overcome the ramped surface of the cavity 128 and abut the top surface 128b of the cavity 128 to create the feedback.

[0028] Figure 5C illustrates the state of the feedback mechanism 130 once the force applied to the first surface 112 of the brush head 111 is again below the threshold amount. The feedback mechanism automatically returns to the initial position by the action of the spring portion 132, and the oral care device 100 is ready for use.

What is claimed is

1. An oral care device comprising:
a brush portion including a brush head having a plurality of bristles attached thereto; and
a handle portion including a neck, a feedback mechanism, and a base,
wherein the feedback mechanism includes a spring portion and a hammer; and
wherein the feedback mechanism is activated and provides feedback when force exceeding a threshold is applied to a first surface of the brush head.
2. An oral care device according to claim 1, wherein the feedback mechanism provides an
audible feedback when activated.
3. An oral care device according to claim 1, wherein the feedback mechanism provides a
haptic feedback when activated.
4. An oral care device according to claim 1, wherein the head is removable.
5. A handle for a feedback toothbrush comprising:
a neck;
a feedback mechanism; and
a base,
wherein, the feedback mechanism includes a spring portion and a hammer; and
wherein the feedback mechanism is activated and provides feedback when force exceeding a threshold is applied to a first surface of the brush head.

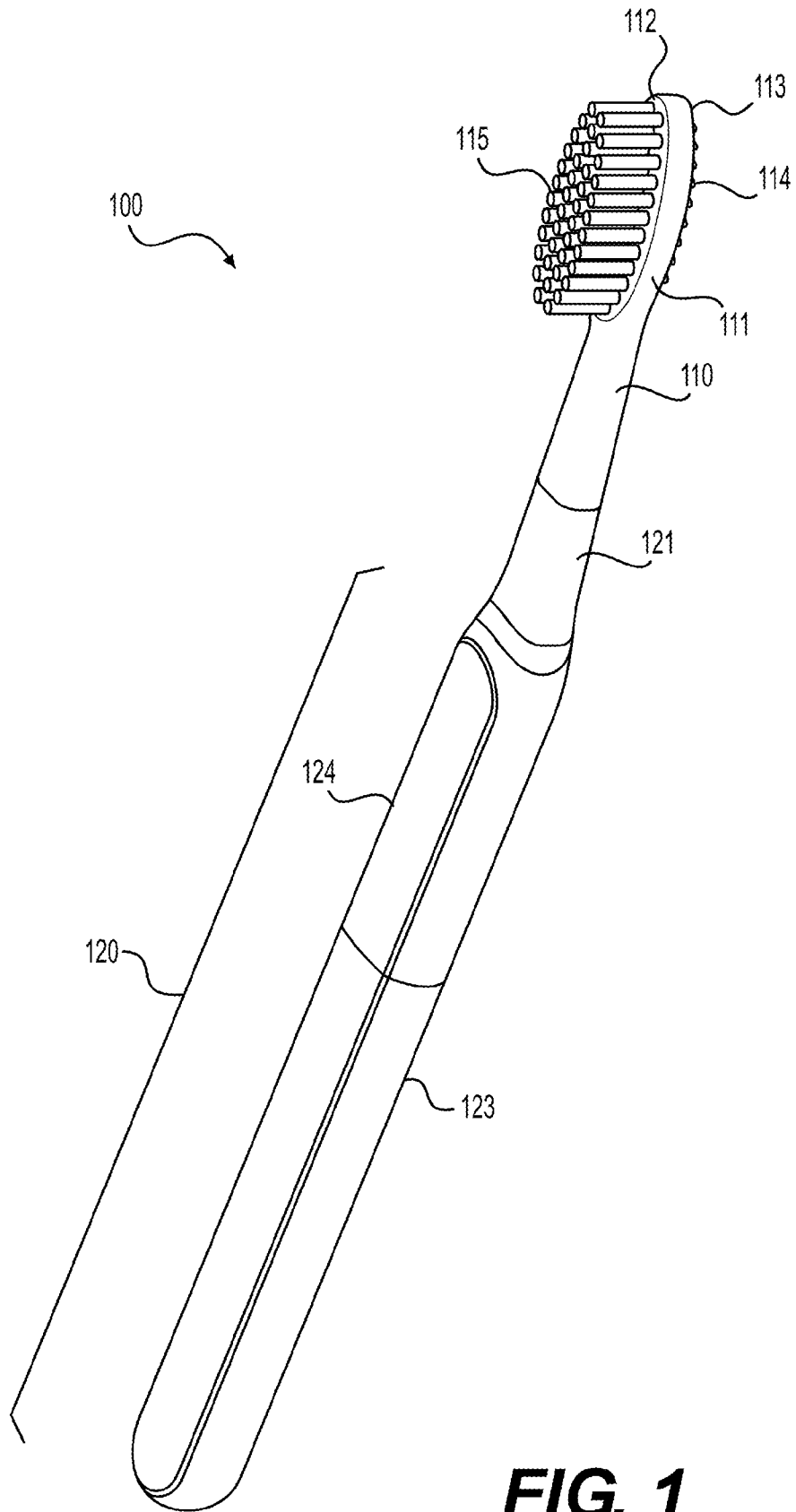
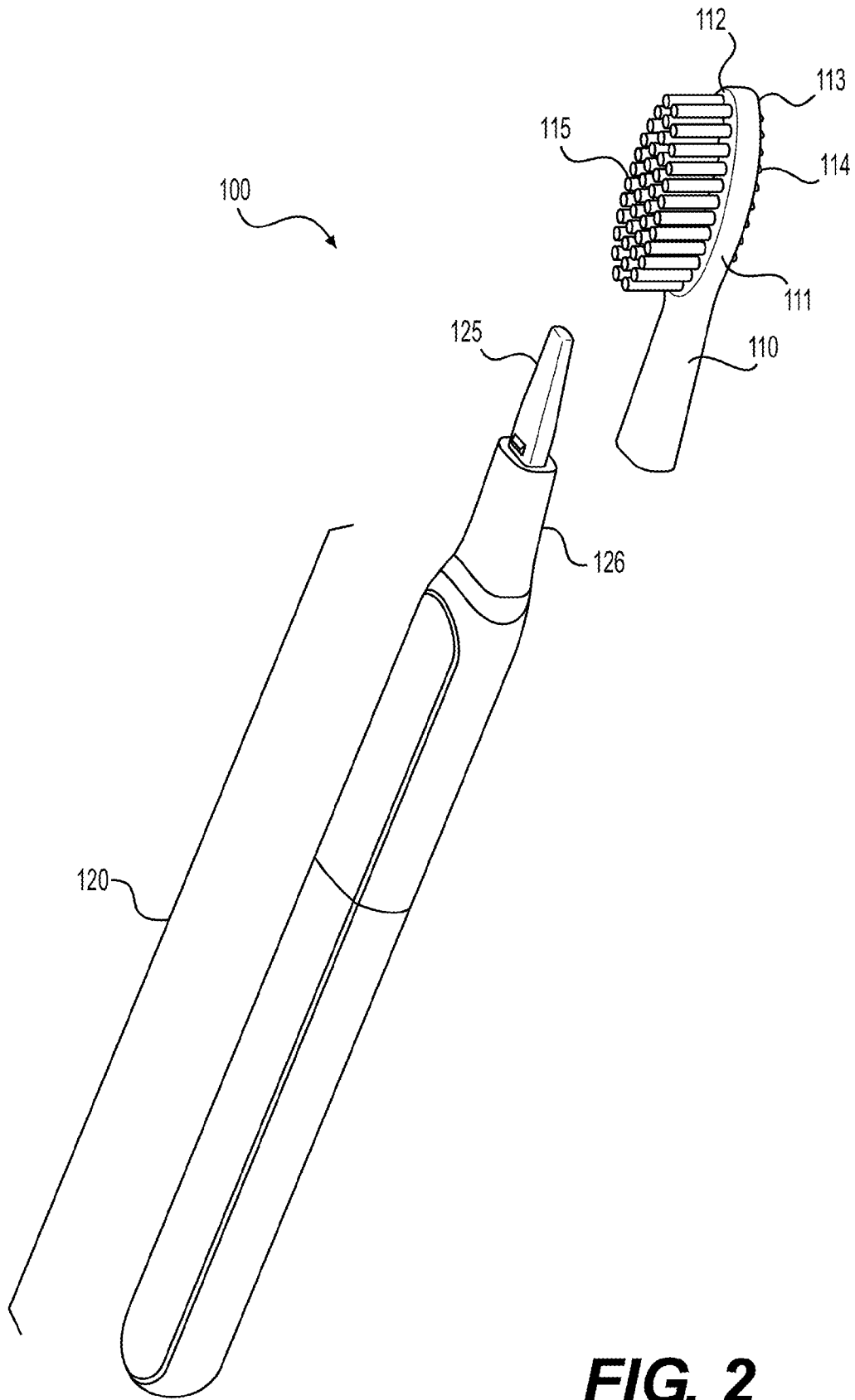

FIG. 1



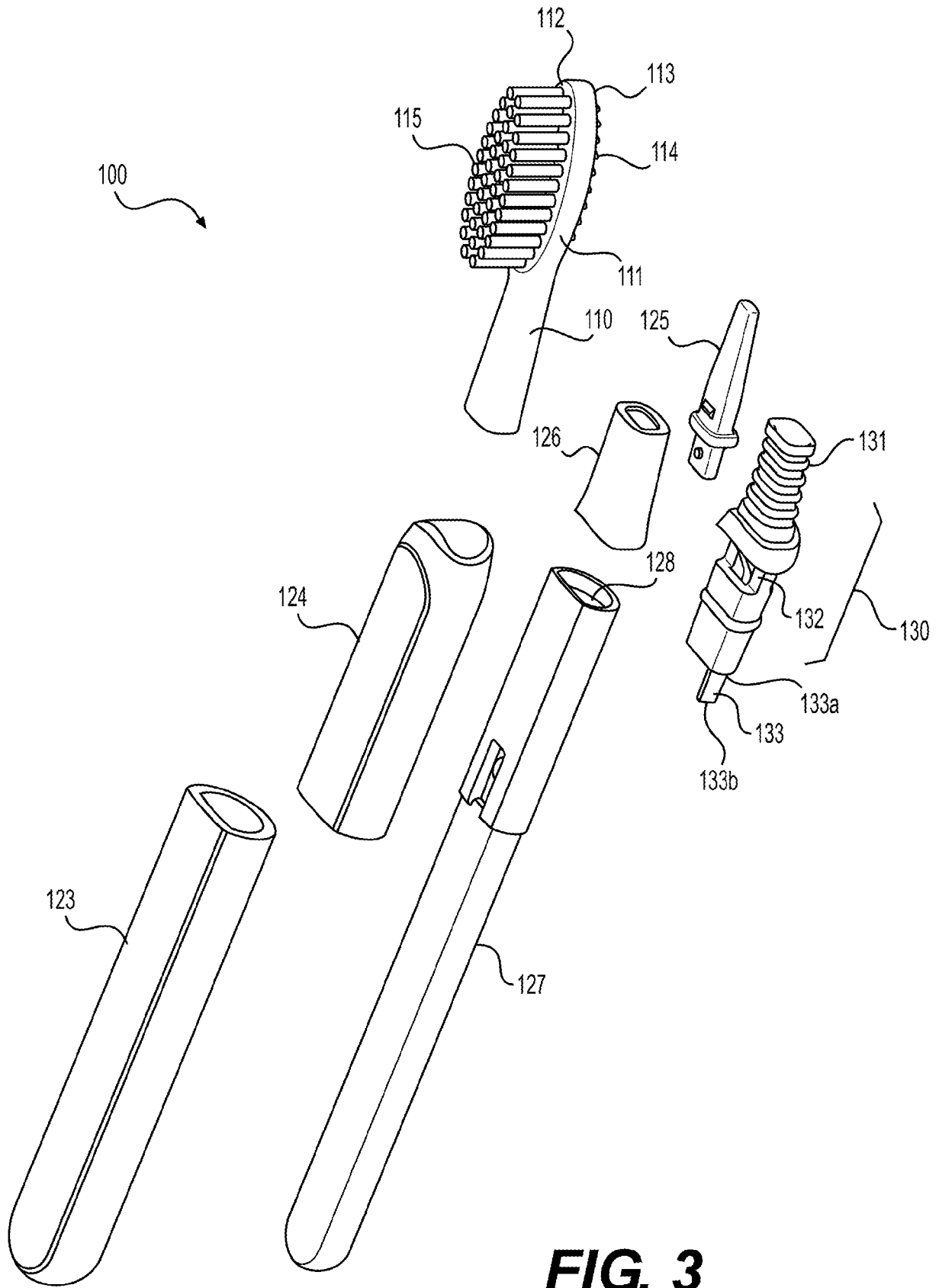

FIG. 3

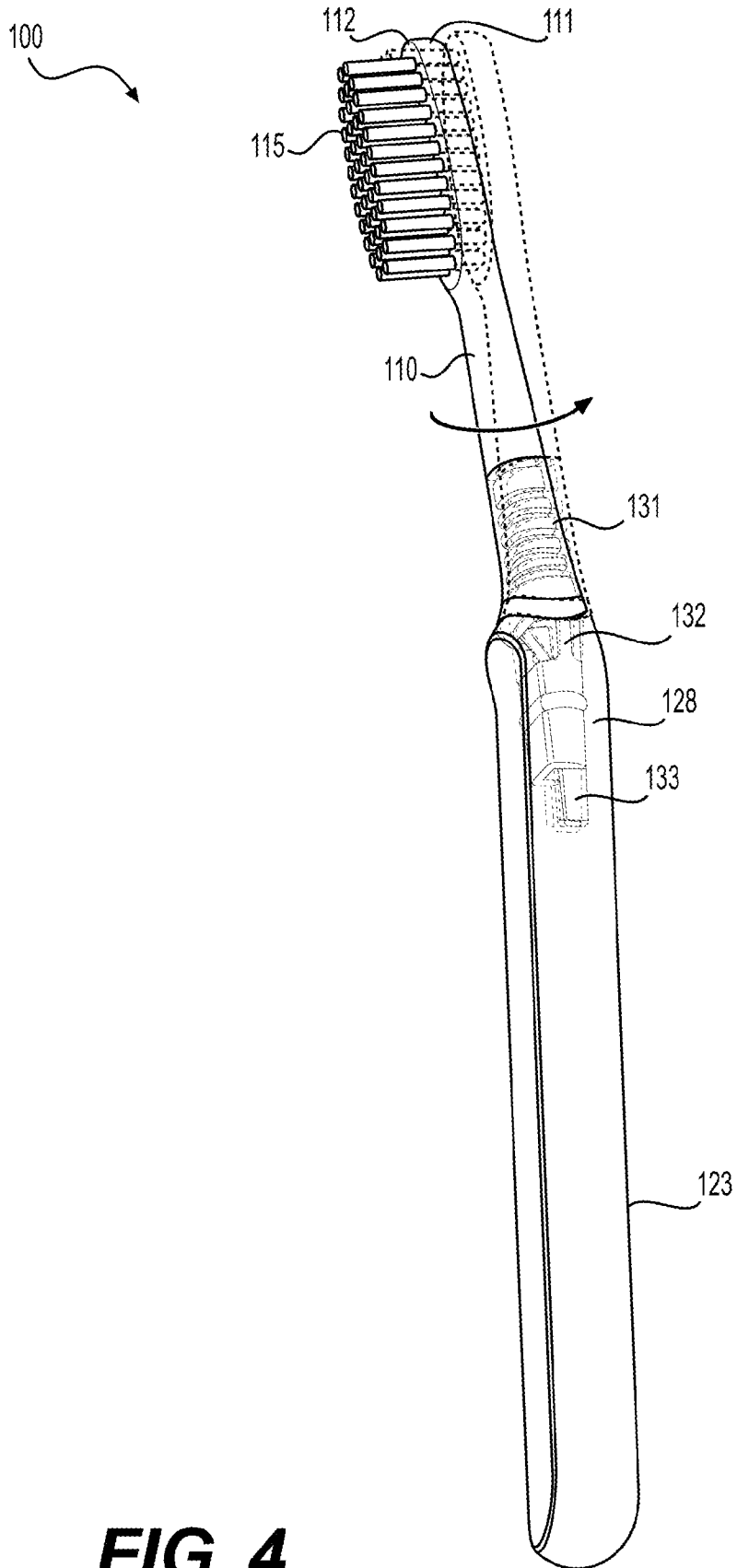

FIG. 4

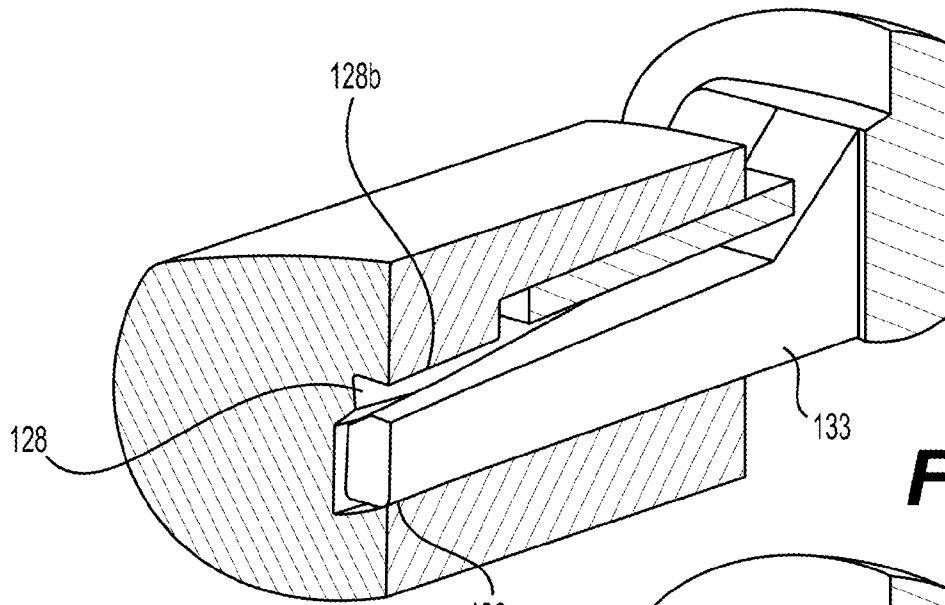

FIG. 5A

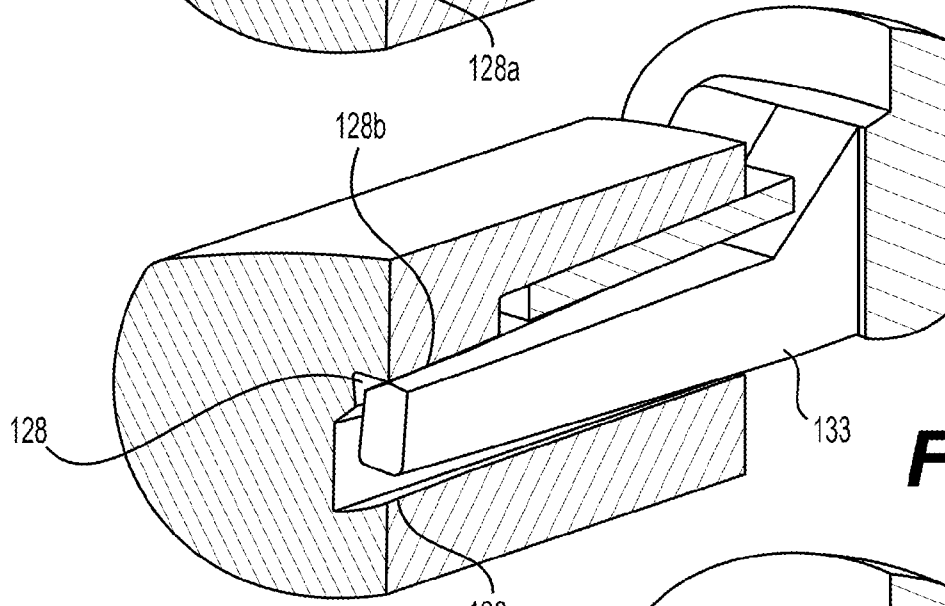

FIG. 5B

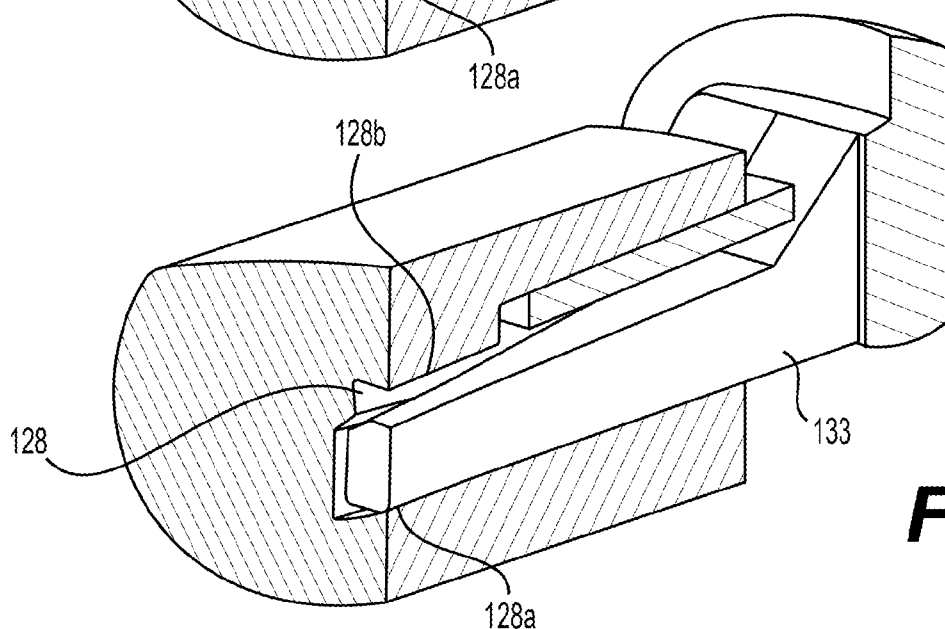

FIG. 5C

INTERNATIONAL SEARCH REPORT

International application No PCT/IB2024/055446

A. CLASSIFICATION OF SUBJECT MATTER
 INV. A46B15/00 A46B5/00
 ADD.

According to International Patent Classification (IPC) or to both national classification and IPC

B. FIELDS SEARCHED

Minimum documentation searched (classification system followed by classification symbols)
A46B

Documentation searched other than minimum documentation to the extent that such documents are included in the fields searched

Electronic data base consulted during the international search (name of data base and, where practicable, search terms used)
EPO-Internal

C. DOCUMENTS CONSIDERED TO BE RELEVANT

Category*	Citation of document, with indication, where appropriate, of the relevant passages	Relevant to claim No.
X	US 2010/325828 A1 (BRAUN PHILIP MAURICE [US] ET AL) 30 December 2010 (2010-12-30) paragraphs [0023], [0044] - [0046], [0049]; figures 1,3a,3b,4 -----	1 - 5
X	US 2014/020198 A1 (SLOCUM ALEXANDER H [US] ET AL) 23 January 2014 (2014-01-23) paragraphs [0039] - [0044]; claim 1; figures 4-5 -----	1 - 3
X	US 2016/174699 A1 (DOLL ALEXANDER FRANZ [DE] ET AL) 23 June 2016 (2016-06-23) paragraph [0012]; figures 5a-5b -----	1 - 3

Further documents are listed in the continuation of Box C. See patent family annex.

* Special categories of cited documents :

<p>"A" document defining the general state of the art which is not considered to be of particular relevance</p> <p>"E" earlier application or patent but published on or after the international filing date</p> <p>"L" document which may throw doubts on priority claim(s) or which is cited to establish the publication date of another citation or other special reason (as specified)</p> <p>"O" document referring to an oral disclosure, use, exhibition or other means</p> <p>"P" document published prior to the international filing date but later than the priority date claimed</p>	<p>"T" later document published after the international filing date or priority date and not in conflict with the application but cited to understand the principle or theory underlying the invention</p> <p>"X" document of particular relevance; the claimed invention cannot be considered novel or cannot be considered to involve an inventive step when the document is taken alone</p> <p>"Y" document of particular relevance; the claimed invention cannot be considered to involve an inventive step when the document is combined with one or more other such documents, such combination being obvious to a person skilled in the art</p> <p>"&" document member of the same patent family</p>
---	---

Date of the actual completion of the international search 19 August 2024	Date of mailing of the international search report 09/09/2024
--	---

Name and mailing address of the ISA/ European Patent Office, P.B. 5818 Patentlaan 2 NL - 2280 HV Rijswijk Tel. (+31-70) 340-2040, Fax: (+31-70) 340-3016	Authorized officer Rossini, Marco
--	---

INTERNATIONAL SEARCH REPORT

Information on patent family members

International application No

PCT/IB2024/055446

Patent document cited in search report	Publication date	Patent family member(s)	Publication date
US 2010325828 A1	30-12-2010	BR PI1013790 A2	05-04-2016
		CA 2766373 A1	29-12-2010
		CN 102802465 A	28-11-2012
		EP 2445374 A1	02-05-2012
		ES 2606828 T3	28-03-2017
		HK 1174512 A1	14-06-2013
		PL 2445374 T3	28-04-2017
		US 2010325828 A1	30-12-2010
		WO 2010151582 A1	29-12-2010

US 2014020198 A1	23-01-2014	US 2014020198 A1	23-01-2014
		WO 2014018323 A1	30-01-2014

US 2016174699 A1	23-06-2016	AU 2015362735 A1	15-06-2017
		BR 112017011462 A2	03-04-2018
		CA 2969761 A1	23-06-2016
		CN 106998901 A	01-08-2017
		EP 3232858 A1	25-10-2017
		KR 20170084197 A	19-07-2017
		US 2016174699 A1	23-06-2016
		WO 2016100317 A1	23-06-2016
