



(19) **United States**

(12) **Patent Application Publication**
McQuown et al.

(10) **Pub. No.: US 2002/0059269 A1**

(43) **Pub. Date: May 16, 2002**

(54) **METHOD FOR GUIDING REPAIR OR REPLACEMENT OF PARTS FOR GENERALLY COMPLEX EQUIPMENT**

(57) **ABSTRACT**

(76) Inventors: **Christopher McDonald McQuown**,
Erie, PA (US); **Mark Douglas Smith**,
Jacksonville, FL (US); **James Edward Schlabach**,
Erie, PA (US)

Correspondence Address:
BEUSSE, BROWNLEE, BOWDOIN & WOLTER, P. A.
390 NORTH ORANGE AVENUE
SUITE 2500
ORLANDO, FL 32801 (US)

(21) Appl. No.: **09/839,328**

(22) Filed: **Apr. 20, 2001**

Related U.S. Application Data

(63) Continuation-in-part of application No. 09/644,421, filed on Aug. 23, 2000. Non-provisional of provisional application No. 60/258,747, filed on Dec. 29, 2000.

Publication Classification

(51) **Int. Cl.⁷ G06F 7/00**

(52) **U.S. Cl. 707/100**

Computerized method and system computerized method for guiding equipment service personnel while at an equipment work site through a plurality of tasks for troubleshooting the health of a selected system of a selected equipment to determine the nature and extent of service needed for such system. The method allows to provide a database comprising detailed data for health assessment and servicing of a selected equipment and system thereof, and an expert rule-based troubleshooting wizard for eliciting information regarding the selected equipment and system and for providing troubleshooting instructions to determine the nature of the equipment fault and the servicing required for the selected equipment and system. An input/output device at the work site for communicating with the database is provided. The method allows to select the equipment and the system thereof to be serviced and to access the database to interface with the troubleshooting wizard for the selected equipment and system. The method allows to provide in response to a set of prompts to the personnel from the troubleshooting wizard at least one set of observations selected from the group comprising operational performance of the selected equipment, operational performance of the selected system, and fault indications detected in the equipment and system. The method processes the observation information relative to the troubleshooting wizard to determine whether or not said selected equipment and system needs to be serviced, and if so the nature and extent of that service.

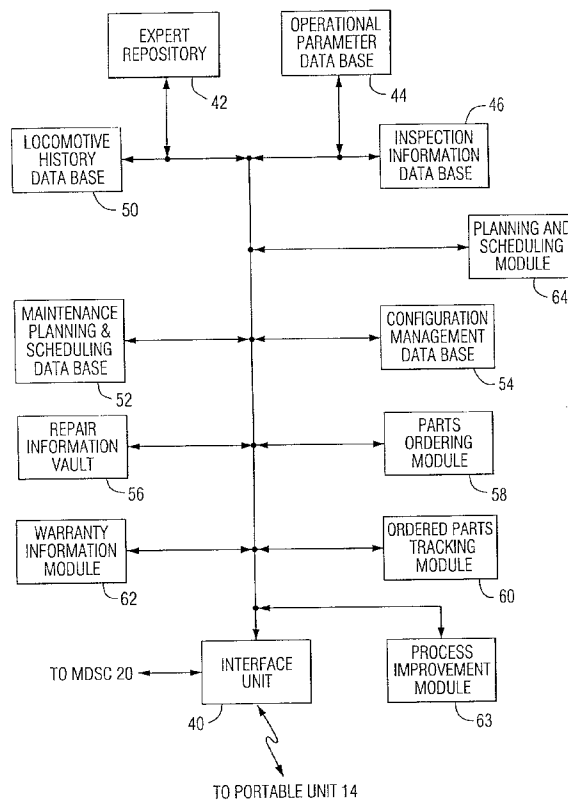

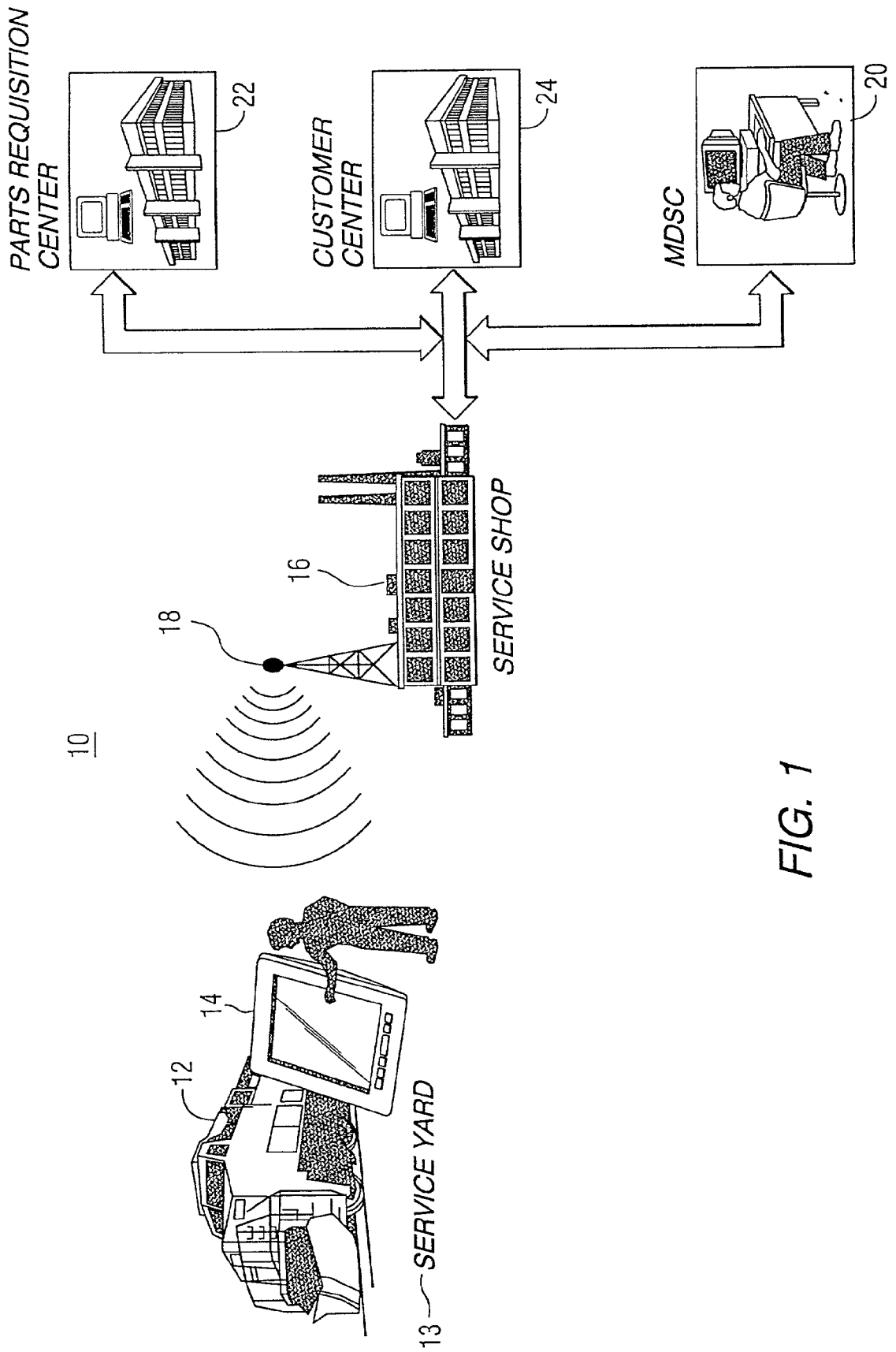

FIG. 1

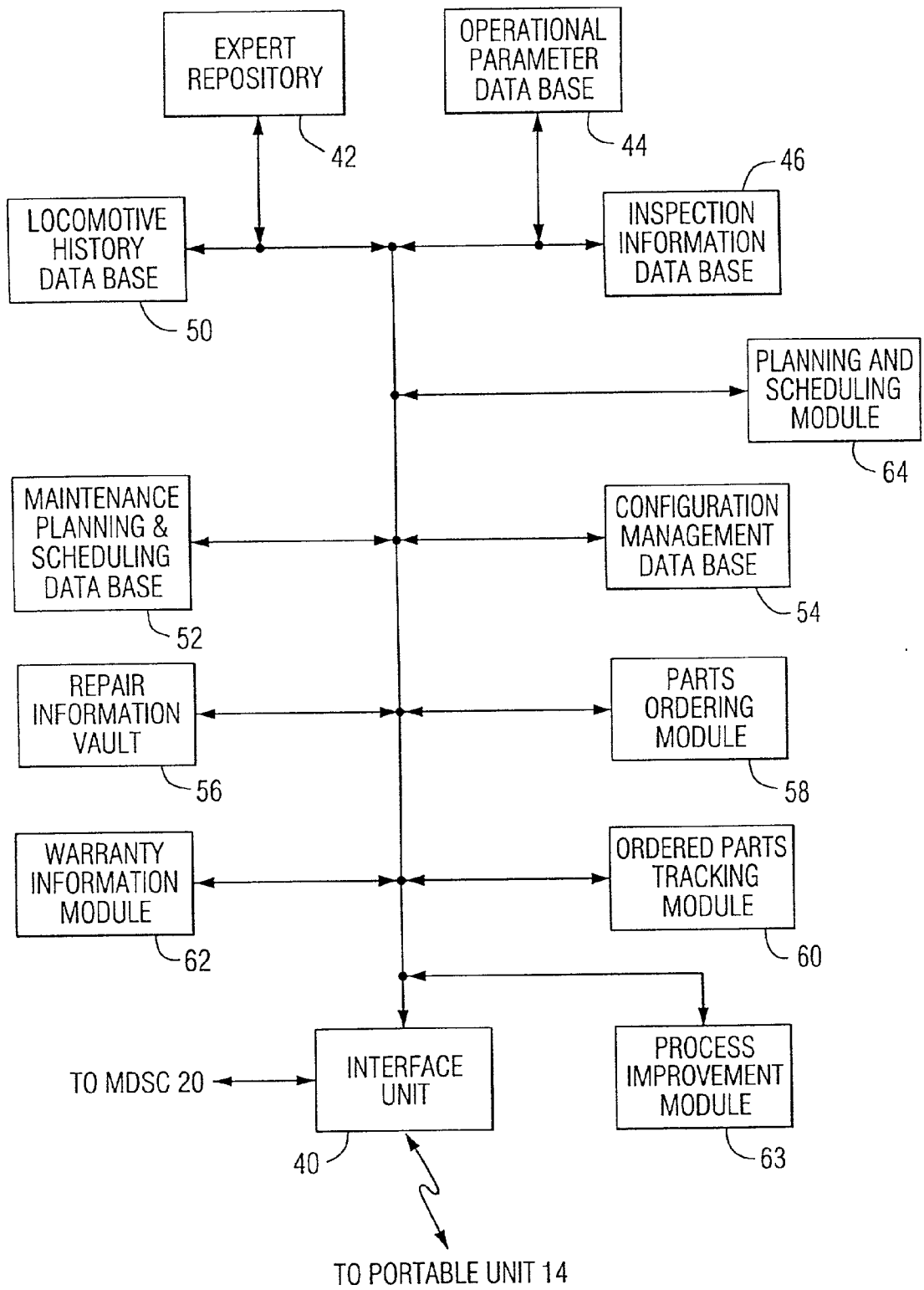

FIG. 2

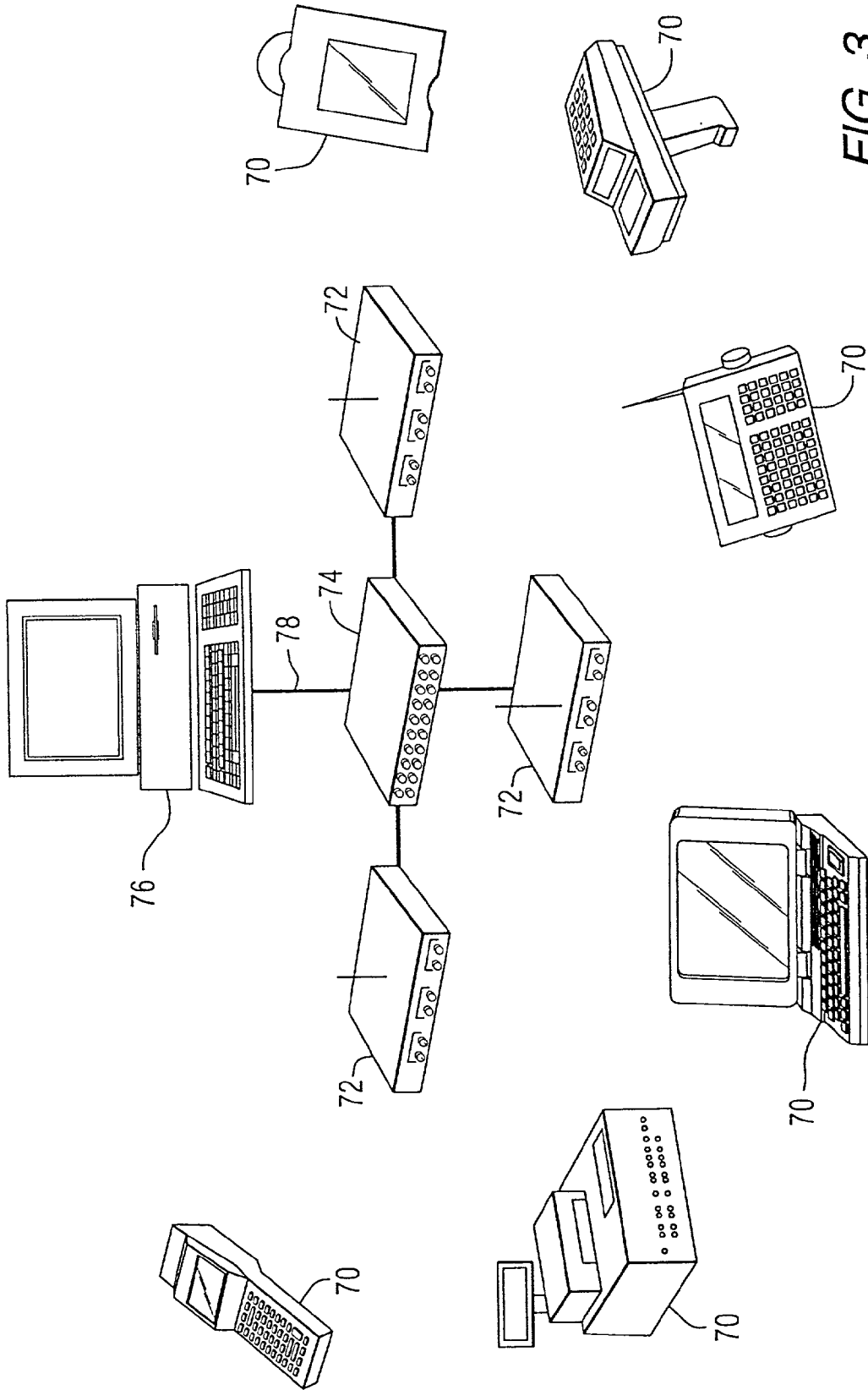

FIG. 3

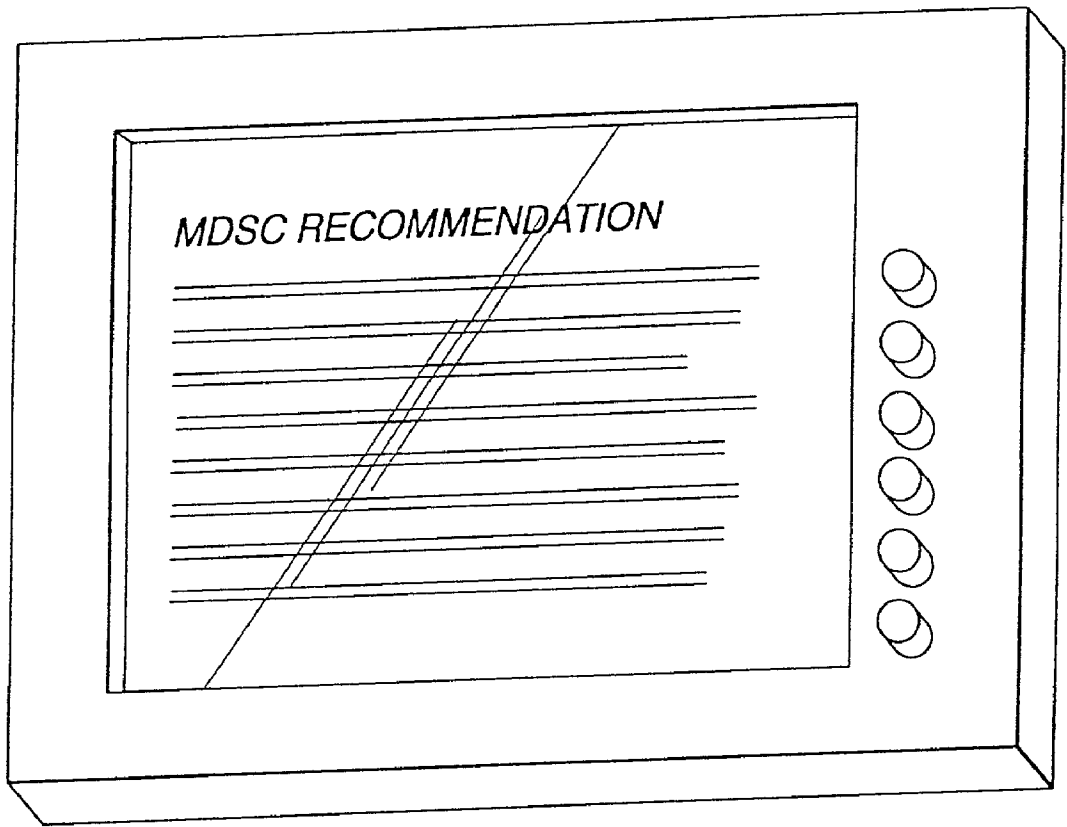

FIG. 4

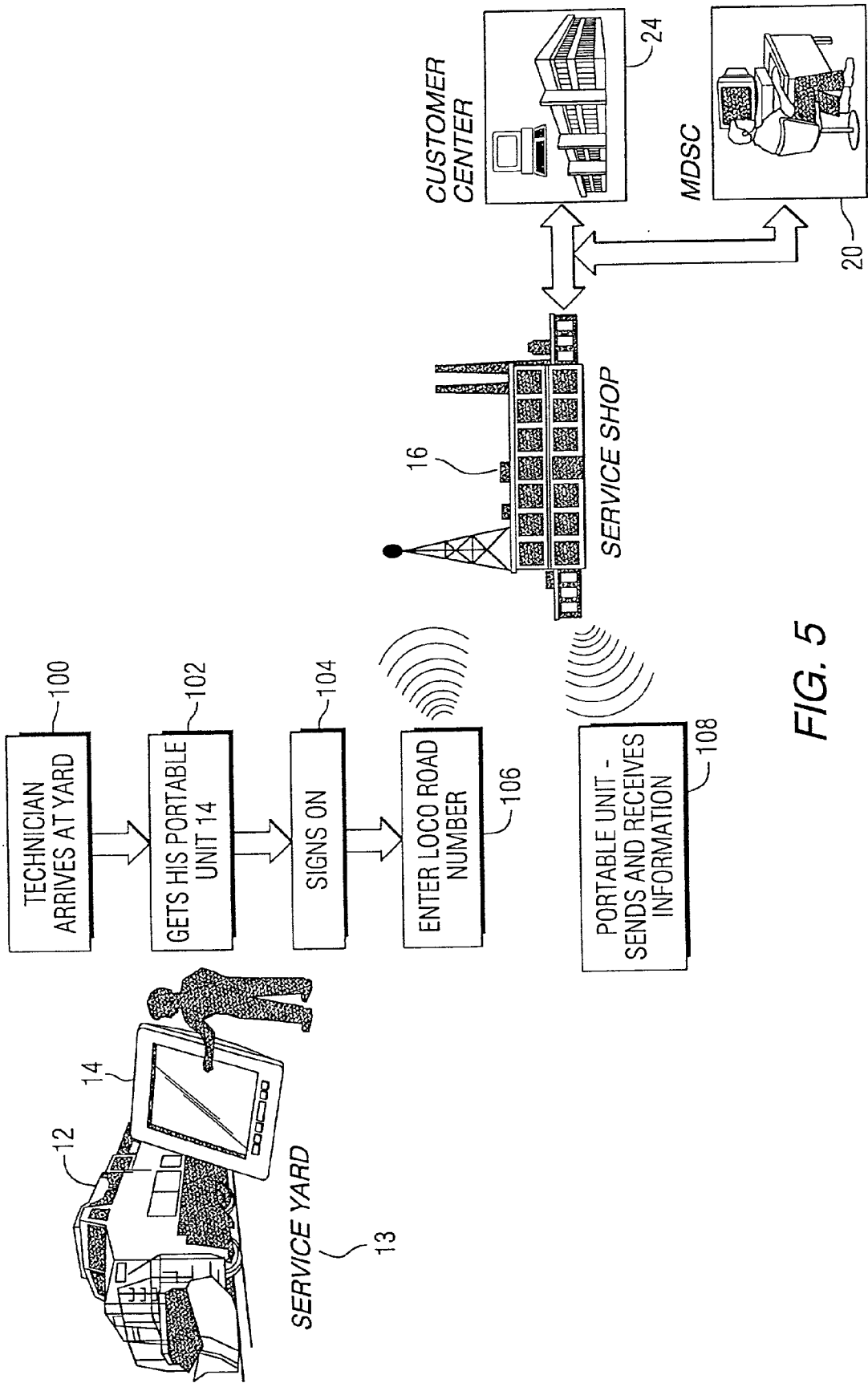

FIG. 5

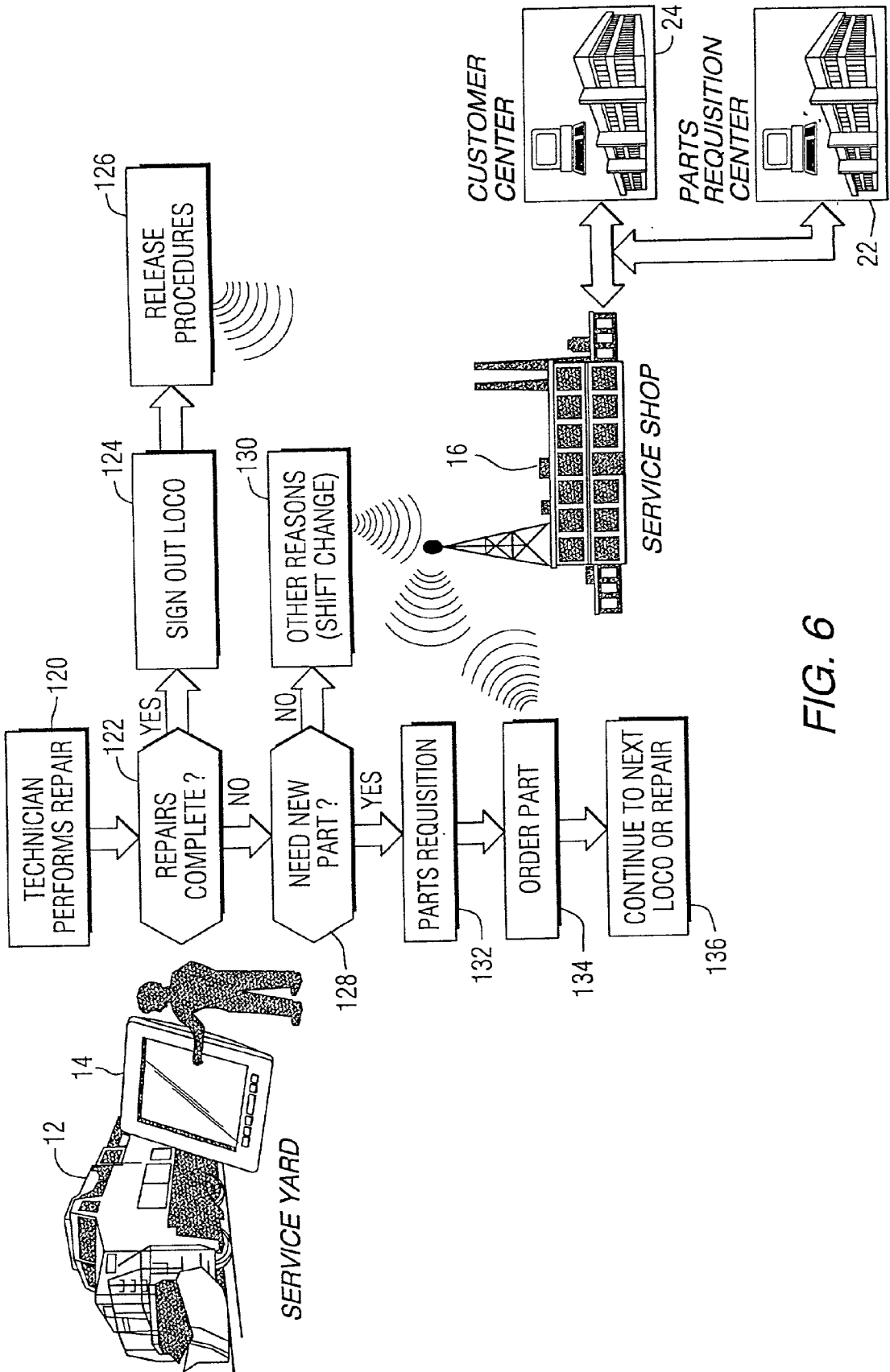

FIG. 6

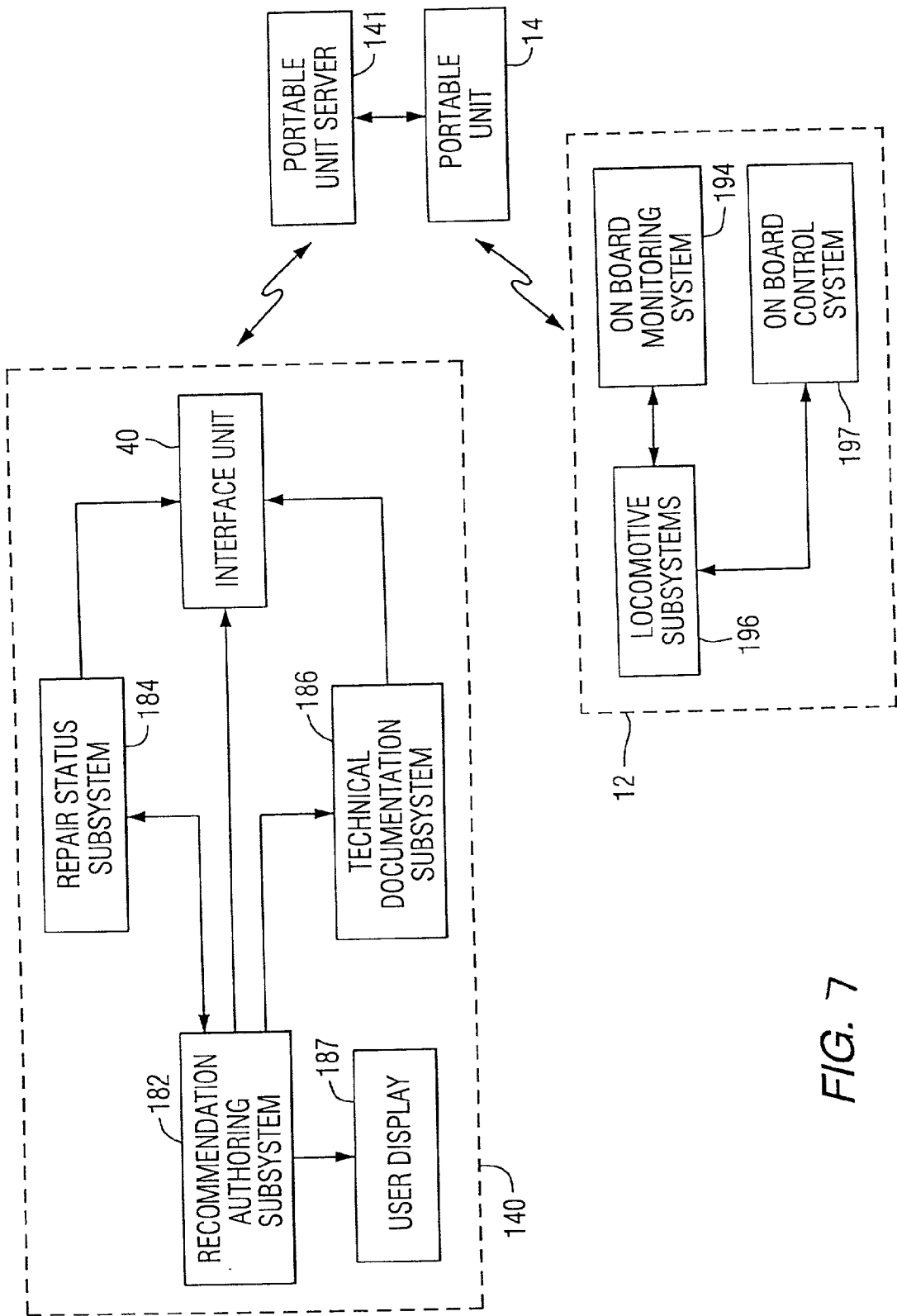

FIG. 7

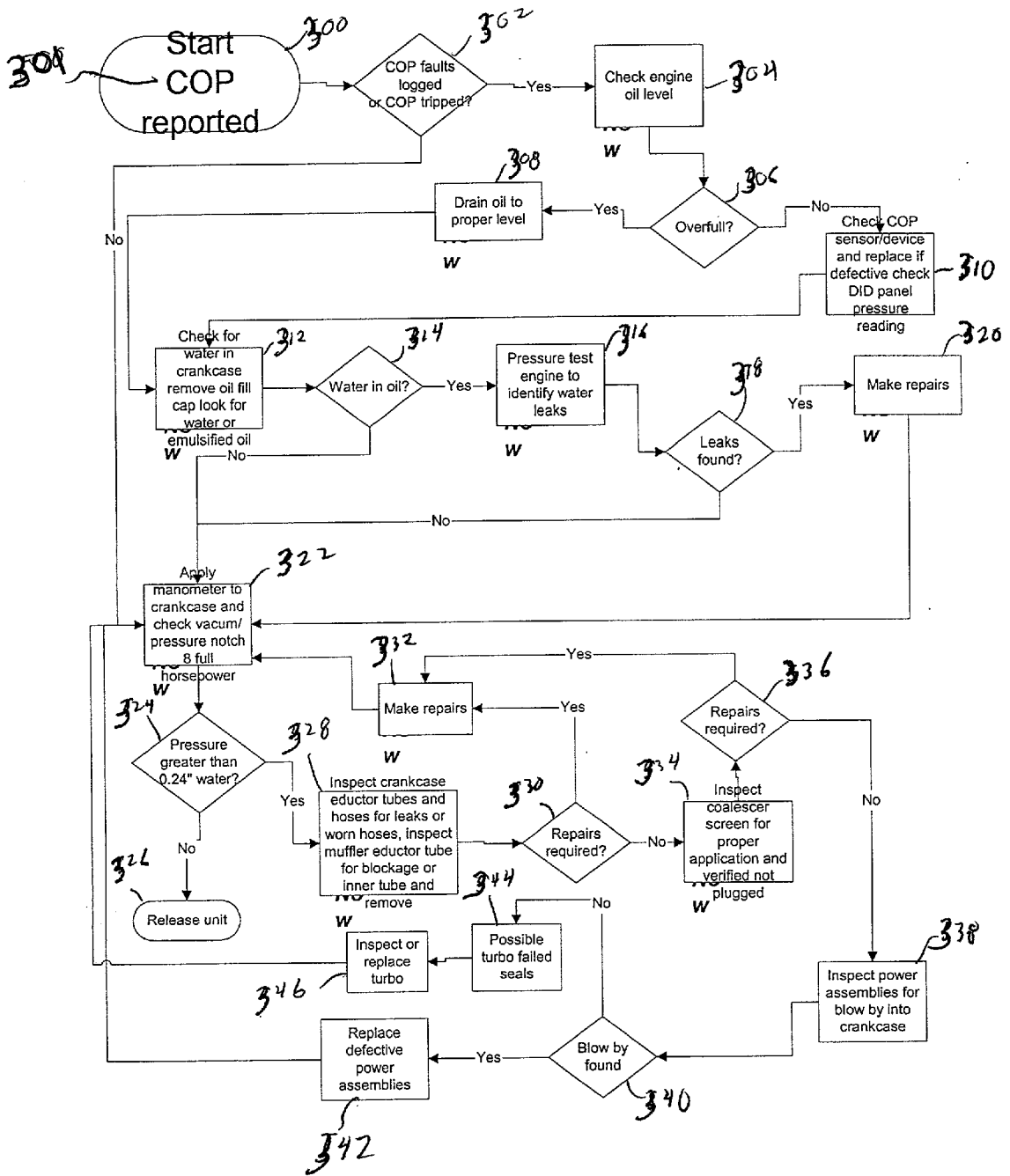

FIG 8

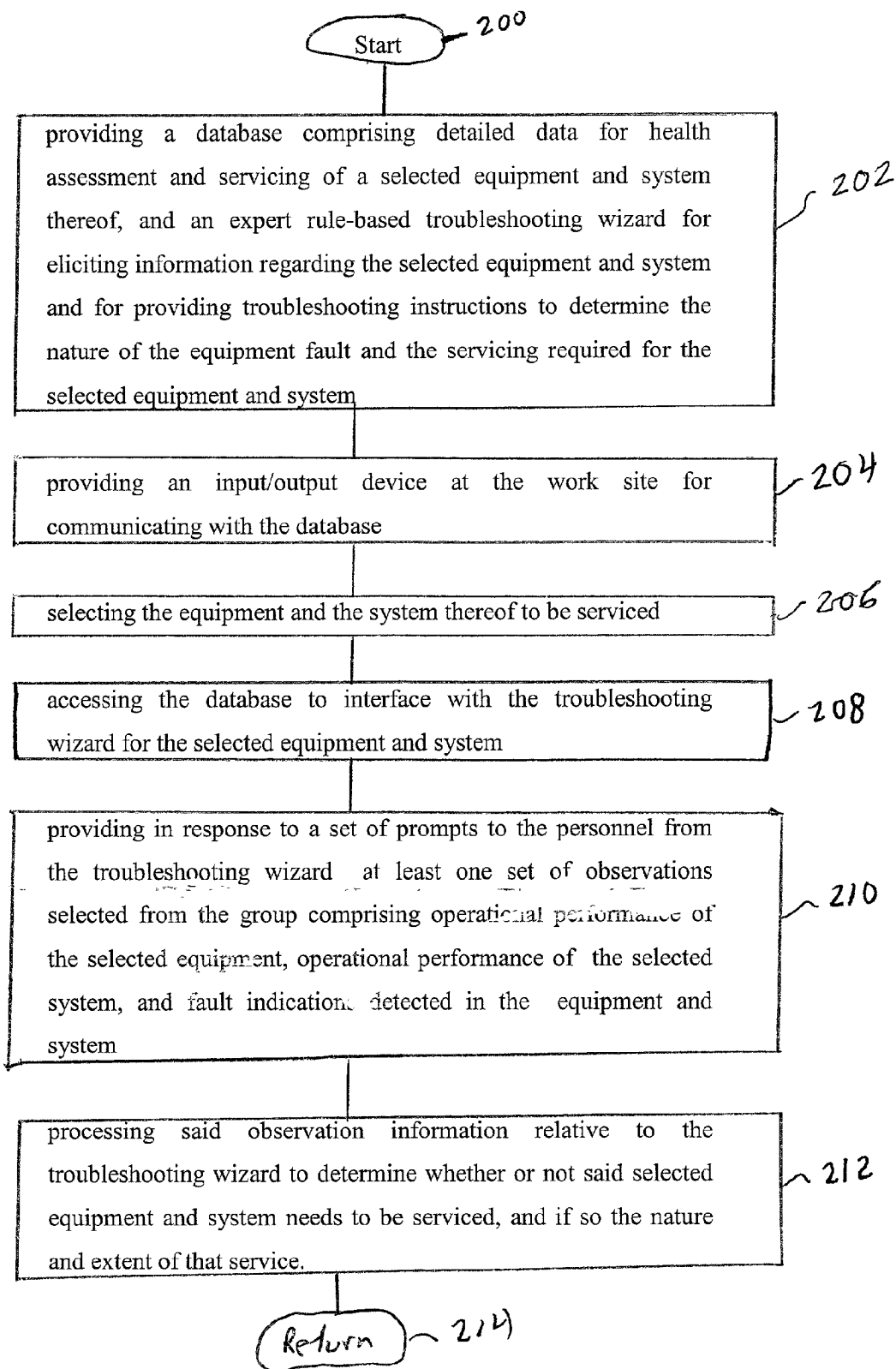

FIG. 9

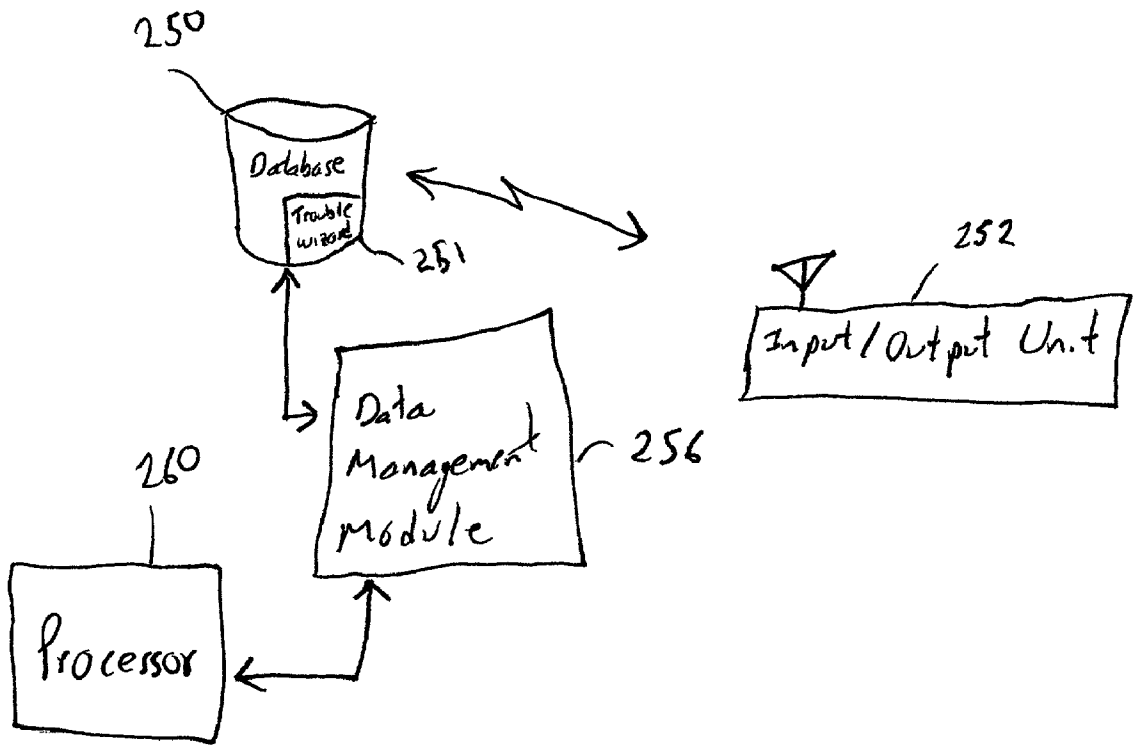

FIG. 10

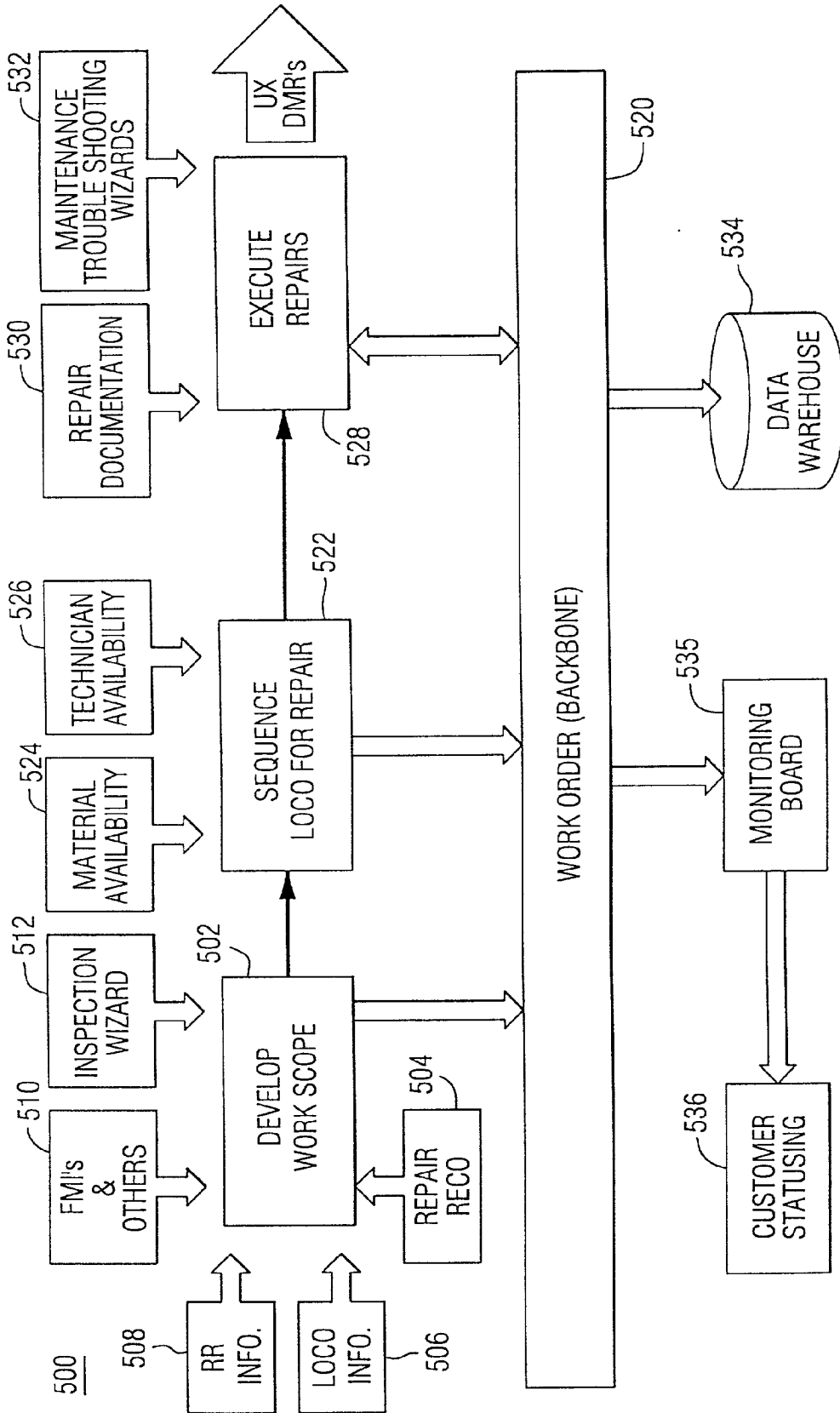

FIG. 11

**METHOD FOR GUIDING REPAIR OR
REPLACEMENT OF PARTS FOR GENERALLY
COMPLEX EQUIPMENT**

[0001] This application is a continuation-in-part of U.S. patent application Ser. No. 09/644,421 and further claims the benefit of U.S. application Ser. No. 60/258,747.

BACKGROUND OF THE INVENTION

[0002] This invention relates to method and system for servicing generally complex equipment, and, more particularly, to computer-based method and system for guiding servicing or replacing of parts of any selected equipment.

[0003] The diagnosis, maintenance, and repair of generally complex equipment, such as mobile assets including on-road or off-road vehicles, ships, airplanes, railroad locomotives, trucks, and other forms of complex equipment including industrial equipment, consumer appliance equipment, medical imaging equipment, equipment used in industrial processes, telecommunications, aerospace applications, power generation, etc., involves extremely complex and time consuming processes. In the case of transportation equipment, efficient and cost-effective operation of a fleet of vehicles necessitates a reduction in the number of vehicle road failures and minimization of vehicle down-time. This can be accomplished by predicting impending failures, by performing preventative maintenance, and by performing repairs quickly and accurately. For example, it will be appreciated that the ability to predict failures before they occur allows for performing condition-based maintenance. Such maintenance can be conveniently scheduled based on statistically and probabilistically meaningful vehicle status information, instead of performing the maintenance regardless of the actual condition of a respective system, subsystem, assembly, subassembly, part, etc., such as would be the case if the maintenance is routinely performed independent of whether any of the foregoing structures actually requires the maintenance.

[0004] The conventional diagnosis and repair process for most vehicles and other generally complex equipment is based on the experience of the service technician, using paper-based information describing the structure and operation of the equipment, and performance records maintained in a log. Examining the log entries, experienced service technicians can use their accumulated experience and training in mapping incidents occurring in locomotive systems, subsystems, assemblies, subassemblies, etc., to problems that may be causing these incidents. For simple problems, this process works well. However, if the problem is complex and the root cause difficult to discern, the experienced technician may be unable to identify the problem and certainly much less likely to prognosticate problems before they occur.

[0005] Various equipment often incorporates diagnostic controls and sensors that report faults when anomalous operating conditions of the equipment arise. Typically, to diagnose the problem, a technician will study the fault log to identify the nature of the problem and determine whether a repair is necessary. While the fault log can provide some diagnosis and repair information, the technician also relies substantially on his prior experiences with the equipment, or others like it, to make a full diagnosis.

[0006] To conduct the repair, the technician uses block diagrams, exploded diagrams, parts lists, assembly drawings, schematics, etc. The repair information may be applicable only to a specific equipment by model number; the repair information will generally not be unique to the specific equipment undergoing repair. It will be apparent that as the complexity of the equipment increases, the amount of paper needed to describe the equipment to assist with the repair process likewise increases. Again, the technician will rely on his experiences with the equipment, and others like it, to perform the repair.

[0007] Yet another problem with a paper-based system is the variety of field-deployed equipment configurations, each having its own unique technical support documentation. In the case of locomotives, even for a specific model (identified by a model number), there may be several locomotive configurations as locomotive subsystems were redesigned or changed during the model production run. Thus, in a sense, no two locomotives are the same. Adding this configuration complexity to a paper-based system presents an inordinately complex and unmanageable problem of locating the correct technical repair documentation for a specific locomotive.

[0008] Another repair issue involving complex equipment, such as railroad locomotives or other mobile or stationary assets, is the unavailability of a repair history from which one could predict component failures and undertake preventative maintenance beforehand. Technicians with wide ranging and lengthy experiences may be able to predict a component failure and repair it to avoid a breakdown during operation, in some limited situations.

[0009] One tool available for locomotive repair manually downloads fault logs from a locomotive while it is parked at a maintenance facility. These fault logs are then uploaded to the railroad maintenance service center. The tool also includes standardized helpful hints for repair tasks and fault analysis descriptors based on single failure faults. Although such a device represents an improvement over a paper-based system, it falls short of the informational needs for a complex equipment, such as a locomotive, and fails to advantageously utilize the various technologies available for more efficiently predicting and performing the repair.

[0010] The techniques of the present invention in one aspect thereof may be useful in identifying and ordering replacement parts for complex equipment having multiple configurations. For example, while locomotives are routinely sold under particular model numbers, each locomotive is typically customized for a particular application or customer. Consequently, when a user needs to identify replacement or repair parts or check on upgrades for a particular locomotive, it is often difficult for that user to particularly identify the needed part or upgrade without knowing more about the particular locomotive. In many instances, the user may not know the particular parts or level of upgrade of a locomotive that is in use. However, manufacturers of locomotives generally keep detailed records of the status of each part or assembly or sub-assembly of a locomotive during manufacture and also track upgrades to that locomotive since such upgrades are normally done by purchase of upgrade kits from the original manufacturer. Accordingly, it is common for a locomotive user to contact the locomotive manufacturer in order to identify replacement parts or upgrades for a locomotive. Thus, it would be advantageous

for service personnel to have access via a communications network to detailed information concerning the parts content or upgrade status of any selected equipment that may be ready to undergo a servicing activity.

BRIEF SUMMARY OF THE INVENTION

[0011] Generally, the present invention fulfills the foregoing needs by providing in one aspect thereof a computerized method for guiding equipment service personnel while at an equipment work site through a plurality of tasks for troubleshooting the health of a selected system of a selected equipment to determine the nature and extent of service needed for such system. The method provides a database comprising detailed data for health assessment and servicing of a selected equipment and system thereof, and an expert rule-based troubleshooting wizard for eliciting information regarding the selected equipment and system and for providing troubleshooting instructions to determine the nature of the for such system. The method provides a database comprising detailed data for health assessment and servicing of a selected equipment and system thereof, and an expert rule-based troubleshooting wizard for eliciting information regarding the selected equipment and system and for providing troubleshooting instructions to determine the nature of the equipment fault and the servicing required for the selected equipment and system. An input/output device at the work site for communicating with the database is provided. The method further provides for selecting the equipment and the system thereof to be serviced and for accessing the database to interface with the troubleshooting wizard for the selected equipment and system. The method also provides in response to a set of prompts to the personnel from the troubleshooting wizard at least one set of observations selected from the group comprising operational performance of the selected equipment, operational performance of the selected system, and fault indications detected in the equipment and system. The method processes the observation information relative to the troubleshooting wizard to determine whether or not said selected equipment and system needs to be serviced, and if so the nature and extent of that service.

[0012] The present invention further fulfills the foregoing needs by providing in another aspect thereof a computerized system for guiding equipment service personnel while at an equipment work site through a plurality of tasks for troubleshooting the health of a selected system of a selected equipment to determine the nature and extent of service needed for such system. The system includes a database comprising detailed data for health assessment and servicing of a selected equipment and system thereof, and an expert rule-based troubleshooting wizard for eliciting information regarding the selected equipment and system and for providing troubleshooting instructions to determine the nature of the equipment fault and the servicing required for the selected equipment and system. An input/output device is provided at the work site for communicating with the database and selecting the equipment and the system thereof to be serviced. A data management module is configured to access the database to interface with the troubleshooting wizard for the selected equipment and system. The data management module also supplies, in response to a set of prompts to the personnel from the troubleshooting wizard, at least one set of observations selected from the group comprising operational performance of the selected equipment,

operational performance of the selected system, and fault indications detected in the equipment and system. A processor configured to process said observation information relative to the troubleshooting wizard to determine whether or not said selected equipment and system needs to be serviced, and if so the nature and extent of that service is also provided.

BRIEF DESCRIPTION OF THE DRAWINGS

[0013] The present invention can be more easily understood and the further advantages and uses thereof more readily apparent, when considered in view of the description of various exemplary embodiments and the following figures in which:

[0014] FIG. 1 is a pictorial rendering of an exemplary system that may be used for practicing aspects of the present invention;

[0015] FIG. 2 is a block diagram showing exemplary subsystems for the system of FIG. 1;

[0016] FIG. 3 is a pictorial rendering showing exemplary elements of a wireless embodiment in accordance with one aspect of the present invention;

[0017] FIG. 4 is an exemplary screen display of a portable unit such as may be used to implement aspects of the present invention;

[0018] FIGS. 5 and 6 are respective flow charts illustrating an exemplary repair process for a given equipment;

[0019] FIG. 7 is a block diagram of exemplary components of a system constructed according to aspects of the invention;

[0020] FIG. 8 is a flow chart of an exemplary example of a trouble shooting wizard;

[0021] FIG. 9 is a process flow chart showing operational details of aspects of the present invention;

[0022] FIG. 10 is a block diagram of exemplary components of a system constructed according to aspects of the invention; and

[0023] FIG. 11 is a process flow chart showing operational details of aspects of the present invention.

DETAILED DESCRIPTION OF THE INVENTION

[0024] Before describing in detail various aspects of the present invention, it should be observed that the present invention broadly comprises a novel combination of processing steps/actions and/or hardware/software configured to quickly and reliably meet the servicing needs of generally complex equipment that may comprise multiple generally interrelated systems, assemblies, subassemblies, parts, etc. Accordingly, these processing steps/actions and hardware/software components have been represented by generic processes and elements in the drawings, showing only those specific details that are pertinent to the present invention, so as not to obscure the disclosure with structural details or operational interrelationships that will be readily apparent to those skilled in the art having the benefit of the description herein.

[0025] FIG. 1 is a schematic representation of an exemplary system that may benefit from the techniques of the present invention. Although illustrated and described with respect to a railroad locomotive 12, those skilled in the art will understand that the teachings of the present invention are applicable to many types of equipment, including those which may be part of a large fleet, such as trucks, ships, off-road vehicles, airplanes, etc. The locomotive 12, such as may be parked at a railroad service yard 13, may be serviced by a technician or other service personnel holding a portable unit 14. In one embodiment, the portable unit 14 communicates with a railroad service shop 16 including an antenna 18 via any of various well-known wireless or wired communication systems and protocols, including an Internet connection using the TCP/IP protocols, tone modems, ISDN or XDSL protocols over the public switched telephone network or a cable modem. In one exemplary embodiment, access may be provided to information gathered at a monitoring and diagnostic service center 20 (MDSC) via a communications network, such as the Internet. It will be appreciated that other network configurations may be used. For example, an intranet including the portable unit 14, the service shop 16 and the MDSC 20 can be used to provide communications between these devices. It will be appreciated that the present invention is not limited to embodiments interconnected to the MDSC 20 since many of the techniques of the present invention can be implemented independently of MDSC 20. It will be further appreciated that the techniques of the present invention are not limited to embodiments using a portable unit since it is contemplated that other communication or input/output device, such as a kiosk, computer terminal, or other computer peripherals may be used for enabling the various communications interrelationships described below.

[0026] Repair, maintenance, and diagnostic information is exchanged between the portable unit 14 and the MDSC 20 via the railroad service shop 16. Parts information is exchanged between the portable unit 14 and a parts requisition center 22. Further, contractual information, such as warranty information, is exchanged with a customer center 24. Generally, the parts requisition center 22, the customer center 24, and the MDSC 20 are located remote from the service shop 16 and the service yard 13. The requisition center 22, the customer center 24, the MDSC 20, and the service shop 16 may be linked via a global information network, such as the Internet and the World Wide Web, via an intranet or by point-to-point communications system, examples of which are discussed above. Because the Internet provides the ability to communicate data and information in a multimedia format, it is especially useful for communicating and displaying the large amount of data associated with the repair, maintenance and diagnosis of the locomotive 12.

[0027] Note that in another embodiment, the portable unit 14 can communicate directly (via a wired or wireless system using any of the communications techniques discussed above) with the parts requisition center 22, the customer center 24 and the MDSC 20, rather than communicating through the service shop 16. The portable unit 14 can also interrogate an on-board monitoring and diagnostic system (not specifically shown in FIG. 1) of the locomotive 12. The on-board monitoring and diagnostic system is described in detail in the patent application entitled "On-Board Monitor for a Railroad Locomotive", application Ser. No. 09/696,

368, filed on Oct. 25, 2000, (Attorney docket number 624226.133/20-LC-1978), which is assigned to the owner of the present invention. The on-board monitor monitors certain operational parameters on the locomotive 12 and reports faults and anomalous conditions directly to the MDSC 20 via an independent communications system, as described in the aforementioned patent application.

[0028] While at the locomotive, the technician, using his portable unit 14, has access to a plethora of repair, diagnostic, and operational information needed to efficiently and accurately trouble shoot locomotive problems and undertake the necessary repairs. The portable unit 14 downloads repair recommendations generated by analysis software and/or locomotive repair experts at the MDSC 20. From the portable unit 14, the technician also has access to repair resources, such as repair manuals, field modification instructions, schematics, block diagrams, etc. Special software tools related to the repair task are also available at the portable unit 14, as transmitted from the diagnostic service center 20. The portable unit 14 allows easy and seamless integration of the repair recommendation with the railroad's work order system as managed and controlled at the service shop 16. The system provides parts ordering and parts tracking via communications with the parts requisition center 22. Repair experts at the monitoring and diagnostic service center 20 can also provide individualized assistance to the technician via the portable unit 14, using an instant messaging feature incorporated therein. Problem resolution suggestions and repair actions can be created prior to access by the repair technician or they can be authored in real time by experts at the monitoring and diagnostic service center 20 and immediately transmitted to the portable unit 14. The repair technician can also provide visual information back to the monitoring and diagnostic center 20 (over an Internet connection, for example) using a camera attached to the portable unit 14. Still or video images can be provided by such a camera. The video information may also be accompanied by live audio information (as spoken by the technician), thereby allowing the technician to communicate with personnel at the monitoring and diagnostic service center 20 to confer about a particular problem or repair action. In those cases where the locomotive components include a bar code for encoding certain features or characteristics of the component, a bar code reader attached to the portable unit 14 can be used to decode the bar code information and transmit the decoded information (or the bar code itself) to the monitoring and diagnostic service center 20 over the communication links previously described. The portable unit 14 and its visual interface replace the prior art paper-based information, thereby simplifying and expediting the repair process. Upon completion of the repair, the portable unit 14 generates a feedback report describing the nature of the problem and the repair actions taken. This report is sent to the monitoring and diagnostic service center 20, where it will be included with the repair history for that locomotive.

[0029] It will be appreciated that the present invention provides the technician with essentially all the information he needs to effectively conduct the diagnosis and repair procedures, relying on information that is transmitted from sources distant from the repair site. Having all this information available, including help from repair experts, avoids the use of paper copies, and ensures a quick and accurate diagnosis and repair of the locomotive 12. Further, via the portable unit 14, the technician can request individualized

expert assistance from the diagnostic service center **20** when problems or issues arise that he is incapable of handling.

[0030] The monitoring and diagnostic service center **20** is operated by personnel who are experts in trouble shooting railroad locomotives. Information received about the locomotive **12** from the portable unit **14** can be electronically processed and then visually displayed to these repair experts. The repair expert analyzes the information and produces a recommendation identifying the potential root cause or root causes of the problem. The repair information is then delivered to the portable unit **14** for execution of the recommended actions in a timely fashion, providing an enhanced degree of accuracy in carrying out the repair procedure.

[0031] There are at least three different classes of maintenance procedures that may be performed on the locomotive **12**. The first are predictive in nature. That is, based on information downloaded from the locomotive **12**, experts at the monitoring and diagnostic service center **20** determine that a given component of the locomotive may be on a path toward eventual failure. It is important for the technician to replace this component to avoid a locomotive failure while it is in operation. The second class of maintenance procedures are those that are planned in advance to occur on a predetermined schedule. These are otherwise known as planned maintenance. Planned maintenance can be based on, for example, the number of locomotive service hours or the number of miles it has traveled since the last maintenance action. Again, the objective is to avoid failure during locomotive operation. In-service failures are especially costly and inefficient for railroad operations, because the locomotive and the train consist may have to be moved back to a service facility to undertake the required repairs. Clearly, this is an expensive and disruptive effort for railroad operations. Finally, the last repair class is those maintenance problems requiring immediate attention due to a component failure that disables or causes derating of the locomotive. With regular and timely predictive and preventive maintenance, the number of maintenance actions in the third category can be minimized.

[0032] Although not illustrated in **FIG. 1**, it is well known in the art that the locomotive **12** may have an on-board monitoring system for monitoring and recording data related to various operational aspects. The on-board monitoring system identifies faulty components and provides fault codes for use by the repair technician in diagnosing the problem. Also, the on-board monitoring system records the number of miles traveled, the amount of fuel consumed, the number of service hours, etc. In some locomotives, there may be more than one on-board monitoring system, each associated with different locomotive subsystems. In any case, the technician, using his portable unit **14**, can access data stored in the on-board monitoring system and transmit it to any of the recipient sites shown in **FIG. 1**. This operational information may be desirable in the diagnostic and repair process. In some cases, depending upon the nature of the fault or anomalous condition, the on-board monitor automatically transmits this information back to the MDSC **20**, where a repair recommendation is formulated and then made available to the portable unit **14**, in a manner to be discussed further below. For those locomotives that do not have an on-board monitor, the technician may have to directly extract information from the locomotive **12** and forward this

information to the MDSC **20**. To extract this information and provide it to the MDSC **20**, the technician may use the video camera or bar code reader in conjunction with the portable unit **14**, as discussed above.

[0033] **FIG. 2** is a block diagram illustrating various exemplary databases and modules to which users, e.g., a technician or any other personnel associated with services operations, may have access (directly or indirectly) through the portable unit **14**. The databases and modules are also linked bi-directionally so that the technician can move seamlessly from one to the other either manually or automatically through a hyperlink process whenever the required information is stored in more than one location.

[0034] The present invention in one aspect thereof contemplates an electronic service delivery system (that is, E-izing) that allows many software applications and databases such as those illustrated in **FIG. 2**, to be available and utilized at the site where a technician is to perform diagnosis, maintenance, or repair services on any mobile asset, such as the locomotive **12**. The present invention provides streamlining and standardizing of service information and multiple processes as well as providing the technician with all the required information needed to repair the locomotive **12** on location.

[0035] An interface unit **40** is shown generally for conditioning data transferred between the various information sources of **FIG. 2** and the portable unit **14**. The interface unit **40** provides data conditioning, modulation or demodulation of a carrier signal to transmit or recover an information signal and signal conditioning for baseband transmission, as dependent on the nature of the communications channel. The interface unit **40** supports both wired and wireless transmissions and their related protocols. Both the portable unit **14** and the MDSC **20** communicate bi-directionally with the various databases and modules of **FIG. 2** for the purpose of entering data into or extracting data from the databases and modules.

[0036] An expert repository **42** stores the repair recommendations authored at the MDSC **20**. These recommendations include: suggested repairs based on operational and/or failure information extracted from the on-board monitoring system of the locomotive derived from symptoms reported by the repair technician, or planned maintenance actions, or field modifications or upgrades. The recommendation can include suggested trouble shooting actions to further refine the repair recommendation and links to appropriate repair instructions, schematics, wiring diagrams, parts catalogs, and trouble shooting guides to make the diagnosis and repair process easier. Diagnosis information can be returned to the MDSC **20** in real time via the portable unit **14** for further analysis in the development and refinement of a repair recommendation. At the MDSC **20**, expert systems, artificial intelligence tools, and case-based reasoning tools are used to develop the specific repair recommendations stored in the expert repository **42**. These tools are discussed in greater detail in the commonly owned patent application entitled "Apparatus and Method for Performance and Fault Data Analysis" bearing patent application Ser. No. 09/629,597, filed on Jul. 31, 2000, (Attorney docket number 624226.144/20-LC-1974, 1975, 1976, 1998). For locomotives having an onboard monitor that generates a specific code for a specific operational fault, that code can be used to retrieve relevant

diagnosis and repair information from the expert repository **42**. The expert repository **42** can also include special procedures providing the technician with up-to-date procedures for performing certain tasks on the locomotive **12**.

[**0037**] An operational parameter database **44** is the storage site for the operational data and information items that are transmitted between the monitoring and diagnostic service center **20** and the locomotive **12**. The transmitted information, which is continually updated as new information is received, includes: fault codes, repair action feedback, repair action analysis, inspection results, operational information, and repair schedules. After recommendations are prepared at the MDSC **20**, they are stored in the operational parameter database **44**, while awaiting transmission to the portable unit **14** for implementation. Operation parametric trending information is also stored within the operational database **44**. The trends can be calculated by comparing operational values over a period of time and comparing those values with historical data or nominal data for similar or identical locomotives.

[**0038**] An inspection information database **46** stores information indicating planned inspection dates for the locomotive **12**. The inspection schedule is unique to each individual locomotive, based on the locomotive identification or road number. When a locomotive is due for inspection, the appropriate inspection procedures, stored in the inspection information database **46**, are transmitted to the portable unit **14**. In one embodiment, the repair procedure includes feedback boxes for each inspection step. These feedback boxes are completed by the technician and automatically generate a summary inspection report that is saved in the repair information database **46** or printed for filing. Procedures for performing rail car and daily locomotive inspections are also stored in the inspection information database **46**.

[**0039**] The inspection information database **46** further includes a wizards module to aid the inspection process. The wizards, which include standard inspection processes to identify locomotive problems, present the inspection process in a step-by-step procedure that eliminates guesswork on the part of the technician. Further, the technician is able to choose the order in which the inspection is conducted only if the individual inspection tasks are not interdependent. The wizards module further provides access to technical information in the expert repository **42** as necessary. In addition to the inspection wizards, maintenance wizards walk the technician through maintenance processes that need to be carefully controlled to ensure a quality result. The steps of the maintenance wizards are integrated with a repair or maintenance work order and may further utilize back-end information (i.e., e-training, technical manuals and schematics). The maintenance wizards also provides access to trouble shooting wizards as appropriate. The trouble shooting wizards isolate a problem to a specific part and then create a work order for the repair of that part.

[**0040**] Using the portable unit **14**, the technician can enter a locomotive identification number or road number to retrieve a history of past repairs from a locomotive history database **50**. A feedback feature associated with each repair task prompts the technician to enter certain information as repair steps are completed. This information is captured at the MDSC **20** and stored in the locomotive history database **50** to create a parts usage history and a record of the repair tasks completed. For example, a serial number and a

description of each part used during a repair is retained within the locomotive history database **50**. Each repair task has an appropriate closing code. The technician closes the repair using the appropriate code, after which the locomotive can be returned to service. The locomotive history database **50** includes three classes of repair: repairs not started, repairs in progress, and closed repairs.

[**0041**] Additional information available to the technician resides in a maintenance planning and scheduling database **52**. Using this database, the technician can access railroad shop management tools and generate and modify locomotive maintenance and repair work orders and schedules. The technician can also access standard work orders and procedures and adapt them as necessary to a specific locomotive. Information concerning repairs in progress is also available in the maintenance planning and scheduling database **52**, on a real time basis. Information about a specific locomotive's "health" is available from the maintenance planning and scheduling database **52** by checking the pending and forecast inspections and repairs. Pending repair or maintenance work orders stored in the maintenance planning and scheduling database **52** include an estimated repair time and the site where the repair is to be performed. Further, each standard repair process is assigned a repair code and each repair code has an associated repair time estimate. Collectively, this repair time information aids the railroad management with scheduling locomotives for return-to-service. The maintenance planning and scheduling database **52** further includes a safety-on-the-job module providing easy and fast access to online safety rules and procedures.

[**0042**] The locomotive repair technicians have quick and easy access to accurate locomotive hardware and software version configurations via a configuration management information database **54**. The hardware and software elements incorporated into a locomotive can be different, even within the same locomotive model. Thus, each locomotive is uniquely identified with a road number and the configuration management information database **54** allows retrieval of configuration information based on the unique locomotive road number. The technician needs accurate knowledge of the locomotive configuration before undertaking a diagnosis or repair. Heretofore, configuration information has been generally available only in paper form, and given the complexity of a railroad locomotive, the amount of paper describing the locomotive and its particular hardware and software configuration can be substantial, and difficult to manage and utilize. Also, the configuration management information database **54** advises the technician when software or hardware changes are required to upgrade the locomotive to the most recent configuration. The configuration management database **54** also includes all field modifications which alert the technician to suggested or mandatory modifications, including instructions for performing them for each locomotive, as issued by the locomotive manufacturer.

[**0043**] The configuration management database **54** also validates software application prior to loading into a specific locomotive **12**. That is, if the software version is not compatible with other hardware or software components of the locomotive **12**, approval for integration will not be granted. The configuration management database **54** can further identify the locomotive for which new software versions apply and can generate a work order for imple-

menting that software version into the locomotive **12**. As a result, software version incompatibility problems are avoided.

[**0044**] A repair information vault **56** includes a homepage address (e.g. a universal resource locator) for each repair code, with a link to repair instructions, schematics, parts catalogues, back shop manuals, operating manuals, drawings, trouble shooting guides, fault analysis manuals, maintenance manuals, video clips, still photographs, audio instructions, etc. All information in the repair information vault **56** is key word searchable by the technician (to avoid page-by-page searching), and all the data is linked (much like World Wide Web hyperlinks) for ease in navigating and locating the appropriate information. For example, acronyms and part numbers are linked to the applicable catalog in the parts-ordering module **58** discussed below. Retrieval of the technical documentation in the repair information vault **56** can be further limited to portions of a larger document to avoid overwhelming the technician with too much information. The repair information vault **56**, in one embodiment, includes a road number navigator to provide a searchable field for retrieving relevant information stored within the information vault **56** by entry of the locomotive road number. The repair information vault **56** further includes a series of online skill-based tutorials ranging from the simplest to the most complicated diagnosis and repair tasks. For instance, the entry level tutorial may provide overall familiarization with the locomotive operating systems and the most advanced level teaches detailed analysis and diagnostic concepts.

[**0045**] The technical documentation included within the repair information vault **56** provides quick and easy access via visual-drill-down techniques to specific sections of the documentation, as required for a given repair. The searchable features offer easy access to specific technical information (e.g., torque values) to improve the accuracy and efficiency of repairs. Specific repair procedures can also be reviewed to improve the safety of the repair process.

[**0046**] The parts-ordering module **58** is also available to the technician via the portable unit **14**. There are two types of parts orders: general inventory orders and repair orders. An online ordering system, included in the parts ordering module **58**, allows direct parts ordering for inventory or for a specific repair, and access to the railroad's parts inventory to determine if the part is already available there. Repair parts ordered for a specific repair are matched with the locomotive configuration to ensure the correct part is obtained. The parts ordering module **58** also provides access to online catalogs issued by suppliers of locomotive components. General inventory orders are executed whenever the railroad's inventory for a part falls below a predetermined threshold. The parts ordering module **58** further includes easy-to-use visual navigation allowing the technician to drill down to pictures of a locomotive to pick a specific part without knowledge of the part number. Further, the availability of the required part is indicated and if available, the part can be marked for delivery to the service yard **13**.

[**0047**] The parts-ordering module **58** provides electronic inventory consumption recording so that inventory can be shipped from the supplier to the railroad operator or party responsible for the repair. The parts-ordering module **58** is

integrated with the maintenance planning and scheduling database **52** to insure that parts required for scheduled maintenance activities are available in inventory just prior to the scheduled maintenance. This technique improves the forecasting of inventory purchases and assures that the parts inventory is maintained at an optimum level. Information regarding the number of parts in inventory and the location of such parts (for example, in the geographically distributed inventory shops maintained by the railroad or party providing repair services) is also available in the parts-ordering module **58**.

[**0048**] Once parts are ordered, the ordered parts tracking module **60** allows tracking of all active and historical parts orders for a locomotive, e.g., whether shipped on back order and the quantity ordered. The tracking function can be driven by the locomotive identification number, by the order number or the part number.

[**0049**] A warranty information module **62** allows access to the applicable locomotive warranty documents. By entering a locomotive identification number, personnel can view all warranty information about that locomotive and its components. Warranty claims can also be submitted and tracked via the warranty information module **62**.

[**0050**] A process improvement module **63** provides information and tools (such as data warehouse reports) to analyze the effectiveness of the repair process and the overall operations at the service shop **16**. The process improvement module **63** also tracks cycle time for individual maintenance steps and for the execution of specific repairs.

[**0051**] A shop planning and scheduling module **64** provides current information and processes to plan the maintenance of a plurality of locomotives **12** at the service shop **16** or a service yard **13**. The planning and scheduling module **64** also includes a monitor board or display for identifying the status of the implementation of the service recommendations on each locomotive in the service shop **16** or at the service yard **13**.

[**0052**] All the databases and modules discussed above are available seven days a week and 24 hours a day from the portable unit **14**. There is little or no human intervention required to access them, and thus around the clock availability is ensured.

[**0053**] In those embodiments and/or situations where it is necessary for the technician to extract information from the locomotive **12**, the technician connects the portable unit **14** to a locomotive interface (e.g., an Ethernet connection) to communicate with the locomotive on-board monitoring system. The portable unit user interface guides the collection of information from the locomotive **12** and also provides memory for temporary data storage. Later, the data can be transferred to the railroad service shop **16** and/or to the monitoring and diagnostic service center **20**. In one embodiment, the portable unit **14** includes a bar code scanner for reading the locomotive identification number, part numbers, and serial numbers. Use of a scanner for parts identification ensures accurate information feedback to both the parts ordering module **58** and the ordered parts tracking module **60**. In another embodiment the portable unit **14** includes a camera for providing visual information back to the monitoring and diagnostic service center **20**.

[**0054**] In one embodiment, the portable unit **14** functions as a stand alone device, performing the transactions dis-

cussed above without physical connection to a data portal. As shown in FIG. 3, the portable unit can comprise various styles and configurations, designated by reference character 70. The portable units 70 communicate via an RF wireless link, with one or more access points 72. The access points 72 is connected to an Ethernet hub 74, which then provides connectivity to a host server 76, via an Ethernet based media 78, employing, for example, the TCP/IP protocol. The access points 72 serve as both receivers and transmitters (i.e., transceivers) to both receive information from and transmit information to the portable units 70, including the information discussed above in conjunction with FIG. 2. In one embodiment, one access point 72 can support up to 400 portable units. Various data security measures, including encryption can be employed on the communication link. Use of a wireless link also allows easy expansion, as the wireless scheme can accommodate both small and large wireless networks, and does not require running new wires as the network expands. In another embodiment of the present invention, the portable unit 14 can be connected to a data communications line via a wire based medium, such as the land-based telephone system, a cellular system or a satellite based communication system. Although shown as a relatively simple device including a display, the portable unit 14 in other embodiments, may include a full size monitor, a key board, mouse, printer and/or other related input/output devices for enabling and expanding the interaction between the technician and the portable unit 14. Information is conveniently displayed on the portable unit 14 at the click of a mouse, the touch of a screen, a voice command, etc. dependent upon the specific operational features of the various portable units 70 illustrated in FIG. 3. In one embodiment, the portable unit 14 comprises a handheld ViA computer, loaded with the appropriate software applications, available from ViA, Inc., of Burnsville, Minn.

[0055] The portable unit 14 also offers an instant messaging feature allowing the technician to quickly communicate repair information (for example, fault codes, diagnostic readings, or simple descriptive text) to a repair expert at the monitoring and diagnostic service center 20. The repair expert can respond directly to the technician through the portable unit 14. This feature is intended for use during the collection of additional diagnostic information or when problems are encountered during the course of a repair.

[0056] The portable unit 14 includes a graphical user interface. An exemplary screen is shown in FIG. 4. The information is presented in a clear and concise style so that users with all ranges of experience can adequately use and understand the displayed information. The portable unit 14 offers short cut links to commonly used data and functions for experienced users, with more detailed instructional links for less experienced users. The portable unit 14 also has a back-out feature to move from the current screen to the previous screen, in this way leaving the user with no dead ends. Regardless of the locomotive that is undergoing repair, all applications and information on the portable unit 14 and all file formats, (no matter there origin from one of the many databases illustrated in FIG. 2) utilize the same presentation format and in this way their source will be transparent to the technician.

[0057] FIGS. 5 and 6 are flow charts showing exemplary steps that may be involved in implementing a service recommendation according to one aspect of the present

invention. Typically, the service recommendation is a recommendation for a repair, but the teachings of the present invention are not so limited. Service recommendations can also involve maintenance procedures or diagnostic processes with the objective of finding the root cause for a fault or anomalous condition. At a step 100, a technician arrives at the service yard 13 where the locomotive is parked. The technician retrieves his portable unit 14 (step 102) and signs on at a step 104. At a step 106, the technician enters the locomotive road number or other locomotive identification number, which is transmitted to the service shop 16. FIG. 5 illustrates this transmission through a wireless arrangement, although as will be appreciated by those skilled in the art, there could also be a wire-based connection between the portable unit 14 and the service shop 16. The service shop 16 may then establish a communications connection with the customer center 24 and/or the MDSC 20. The portable unit 14 queries the MDSC 20 for information for the locomotive road number entered at the step 106. The technician may request any of the items discussed in conjunction with FIG. 2, such as repair or maintenance information, historical repairs, etc. Once the requested information is received at the service shop 16, it is sent to the portable unit 14, as illustrated at a step 108.

[0058] Information sent from the portable unit 14 to the MDSC 20 includes problems with a locomotive, the current status of locomotive systems, repair requests, diagnostic information and video clips and still photographs. Locomotive problems may be observed directly by the technician or downloaded from the locomotive on-board monitoring system as previously discussed. Information returned to the portable unit 14 from the customer center 24 and the MDSC 20 includes recommended repairs and relevant technical documentation required to perform the repairs as discussed in conjunction with FIG. 2. This information is displayed on the portable unit 14 to allow the technician to accurately and quickly repair the locomotive. The information displayed on the portable unit 14 includes a pictorial view of the locomotive and its constituent parts, repair steps, technical documentation relevant to the repair, and the tools necessary to perform the repair. Assembly diagrams and assembly instructions are also displayed. Multimedia information, such as video clips or audio instructions can also be transmitted to the portable unit 14 from the MDSC 20. In short, all information discussed in conjunction with FIG. 2 is immediately available to assist the technician with diagnosis, repairing and/or servicing of the locomotive.

[0059] Continuing to FIG. 6, a step 120 represents the technician's execution of the repair or service task. A decision step 122 asks whether the repair has been completed. When completed, processing continues to a step 124 where the locomotive is signed out from the repair site, either the service yard 13 or the service shop 16. At a step 126, release procedures are executed, after which the locomotive is returned to service. The release procedures involve confirming that all necessary steps required for return to service have been completed and generating a notice to railroad operational personnel that the locomotive 12 is ready to return to service.

[0060] If the repair has not been completed at the decision step 122, processing continues to a decision step 128, where inquiry is made as to whether a new part is needed to complete the repair. If a new part is not required, processing

continues to a step **130** to determine why the repair has not been completed. For example, there may have been a work-force shift change during the repair process. In any case, the reasons why the repair has not been completed are communicated to the service shop **16** by the technician via the portable Unit **14**.

[**0061**] If a new part is needed, processing moves from the decision step **128** to a parts requisition step **132**, where, the portable unit **14** communicates with the service shop **16** to requisition the part. A step **134** is executed for those parts that must be ordered from a third party supplier, via the parts requisition center **22**. As illustrated by step **136**, once the part has been ordered, the technician can continue the diagnostic and repair process for another locomotive or perform another repair on the current locomotive.

[**0062**] The electronic data delivery system of the present invention provides in one aspect thereof an improvement in the diagnosis, repair and maintenance of a mobile asset such as the locomotive **12** by applying E-business technologies to replace the prior manual paper-based processes. A benefit derived from applying these technologies includes improved availability of the mobile asset by reducing the cycle time of the repairs and more efficient and focused repair processes. Additionally, by using the various databases and modules illustrated in **FIG. 2**, the many processes related to a repair operation will be measurably improved in accordance with the teaching of the present invention.

[**0063**] The diagnosis and repair system **140**, the portable unit server **141**, and the portable unit **14**, constructed according to aspects of the present invention are illustrated in **FIG. 7**. While **FIG. 2** diagrammatically illustrates the individual databases and information sources accessible to the portable unit **14**, **FIG. 7** depicts aspects of the present invention from the system/subsystem level. The diagnosis and repair system **140** includes a recommendation authoring system **182**, a repair status system **184**, a technical documentation system **186**, and the interface unit **40**, previously discussed in conjunction with **FIG. 2**. With reference to the individual databases and information sources shown in **FIG. 2**, the recommendation authoring subsystem **182** includes the expert repository **42** and the operational parameter database **44**. The repair status subsystem **184** includes the locomotive history database **50**, the maintenance planning and scheduling database **52**, the repair information vault **56**, and the inspection information database **46**. As suggested above, the diagnosis and repair system **140** may communicate with the portable unit **14** via the portable unit server **141**. The communication link between the portable unit server **141** and the interface unit **40** can be either wired or wireless. Likewise, the portable unit **14** communicates (using either a wired or wireless media) with various components aboard the locomotive **12**. In particular, the portable unit **14** extracts data from and provides data to an on-board monitoring system **194**. Also, the portable unit **14** can query other locomotive subsystems, shown generally by a reference character **196**.

[**0064**] The recommendation authoring subsystem **182** provides the functionality for authoring general repair recommendations and instantiating specific recommendations for a locomotive. The recommendation authoring system **182** provides the following exemplary functions: defining the steps involved in a repair, specifying the relevant tech-

nical documentation to accompany the repair recommendation and specifying the data that needs to be collected by the technician to execute the repair. The repair recommendation, instructions, and data to be collected are compiled into a cohesive deliverable package that is eventually delivered to the portable unit **14**. In one embodiment, the compiled information is provided as a web formatted package. By using a web format (or other standardized format) the information can be displayed on the portable unit **14** in a standard format with which the technician will eventually become familiar. Consistency and familiarity with the repair information format allows the technician to efficiently navigate through the information provided and in this way increase his productivity. One feature of the recommendation authoring subsystem **182** is the creation of repair-specific process steps (including all relevant technical documentation necessary to execute each step) for the technician. Using all the general diagnosis, repair and technical information available, the recommendation authoring subsystem **182** selects only that information needed for a specific repair as associated with a specific locomotive based on a unique locomotive designator, such as the road number, and presents this to the technician. With repair-specific information and back-up technical documentation readily available, the technician can more easily and efficiently execute the repair process.

[**0065**] The repair status subsystem **184** maintains and provides information on the status of a repair. This information is based on feedback provided by the technician during and after completion of the repair. The technical documentation subsystem **186** maintains the technical documentation for the locomotives and supports the selection and retrieval of the appropriate technical documentation into a repair-specific set of relevant technical documentation.

[**0066**] The portable unit server **141** disseminates repair instructions to the portable units **14** and collects information from those units. Although only one portable unit **14** is shown in **FIG. 7**, it will be understood that the portable unit server **141** can communicate with many portable units **14**, as shown in **FIG. 3**. It is expected that each technician or team of technicians with service or repair responsibility will have a portable unit **14**. The functionality provided by the portable unit server **141** includes: serving as a communications link to the interface unit **40**, connecting with and identifying each portable unit **14** at power up, transferring feedback files from the portable unit **14** to the diagnosis and repair system **140**, transferring the repair recommendations and relevant technical documentation to the portable unit **14**, synchronizing clock times, validating the identity of the technician using the portable unit **14** and clearing files from the portable unit **14** once these files have been transferred to the portable unit server **141**. In one embodiment of the present invention, the portable unit **14** can communicate directly with the diagnosis and repair system **140**, thus rendering the portable unit server **141** unnecessary. In such an embodiment, the tasks performed by the portable unit server **141** are performed by the diagnosis and repair system **140** and/or by the portable unit **14**.

[**0067**] The portable unit **14** displays the repair instructions to the repair technician and creates a record of the service event. Among the functions of the portable unit **14** are: providing a log in and log out interface, displaying repair instructions and all supporting technical documentation

(including multimedia information), accepting repair feedback information and updating the repair feedback file when a repair action is finished and communicating with the locomotive **12** to extract information from the on-board monitoring system **194** and the other locomotive subsystems **196**.

[0068] In one exemplary embodiment, a principal function of the recommendation authoring subsystem **182** is to select general repair recommendations from the various sources available within the diagnosis and repair system **140** and to transform this information into a set of locomotive-specific, repair-specific instructions and relevant documentation. The recommendation and authoring subsystem **182**, in one embodiment, is located at the monitoring and diagnostic service center **20**. A general repair recommendation is those repair actions (i.e., a sequence of steps to be performed by the technician to execute the repair) that are responsive to a given set of fault codes. These fault codes are downloaded by the portable unit **14** from the on-board monitoring system **194** and the other locomotive subsystems **196**, and provided to the recommendation authoring subsystem **182**. The fault codes may also be communicated directly and automatically to the MDSC **20** from the on-board monitor, as discussed in detail in the aforementioned patent application entitled "On-Board Monitor for a Railroad Locomotive". In the present invention, the general repair recommendations are instantiated into a specific repair recommendation for a given fault that has occurred on a specific (i.e., road number) locomotive **12**. A user display **187** is responsive to the recommendation authoring subsystem **182** for use by the repair expert **142** in formulating the repair recommendation.

[0069] The technical documentation available to the recommendation and authoring subsystem **182** includes parts catalogs, maintenance manuals, schematic diagrams, fault code listings, and back shop manuals, and various multimedia files, such as video or audio instructional materials. This information represents typically-recommended documents needed for a repair. Specific pages and excerpts from this generalized documentation are identified by the recommendation authoring subsystem **182** when the recommendation is instantiated for a particular locomotive repair.

[0070] In one exemplary embodiment, the recommendation authoring system **182** interfaces with the technical documentation subsystem **186** to locate technical documentation and multimedia presentations relevant to the recommendation. The recommendation authoring system **182** provides search criteria to the technical documentation subsystem **186** for retrieving relevant documentation. Included within the search criteria are one or more of the following: part name, part number, action name, repair fault code, and locomotive model. Search scope information is also provided to the technical documentation subsystem **186** for specifying where to look for relevant documentation. Included within the search scope are parts catalogs, maintenance manuals, schematics, back shop manuals, fault analysis pages, field modification instructions, and multimedia files. In response to the inputs, the technical documentation subsystem **186** responds to the recommendation authoring system **182** with the location of the technical documentation that satisfies the search criteria. The output is a list and each entry in the list contains the following information about that entry: location of the page (for subsequent retrieval), size of the file making up the page, the

type of page (i.e., the document source), and the locomotive road number or numbers to which the page applies.

[0071] Another interface between the recommendation authoring subsystem **182** and the technical documentation subsystem **186** provides access to a browsing mechanism within the technical documentation subsystem **186**. This browsing mechanism allows the repair expert to review the documentation pages to determine if it is necessary to refine the search criteria.

[0072] As illustrated in FIG. 7, the recommendation authoring subsystem **182** also interfaces with the repair status subsystem **184**. The recommendation authoring subsystem **182** allows selection of existing general repair recommendations for a specific problem or repair code. Also, the recommendation authoring subsystem **182** inputs a summary of the repair recommendation to the repair status subsystem **184** so that the latter can create an entry in the repair status database for each repair. The repair status subsystem **184** responds to the recommendation authoring subsystem **182** when the repair entry is created. The transmitted summary includes: the repair case number, the date and time that the recommendation was issued, the road number to which it applies, the steps outlined in the repair recommendation, the technical documentation to accompany each repair step, and the repair status. The recommendation authoring subsystem **182** also provides to the repair status subsystem **184** the data store locations for the data entry objects. The purpose of this input is to ensure that the data store locations are recognizable by the repair status subsystem **184**.

[0073] The repair status subsystem **184** also supplies a list of possible locations for storing the values collected by the data entry objects. The repair status subsystem **184** stores these values when they are received following an actual repair event, as part of the repair feedback process.

[0074] The technical documentation subsystem **186** maintains the technical documentation repository and supports the selection and retrieval of technical documentation into a repair specific set of relevant documents by the repair expert. In one embodiment, the technical documentation is available in a web-based format. The technical documentation subsystem **186** supports the retrieval of individual pages or sections from technical documents, rather than retrieval of the entire document. The technical documentation is also indexed. These indexes provide quick identification of document subsets. For example, the indices can support identification of all documentation pages related to a specific part number, a specific part name, or a repair process name. All relevant technical documents are stored in the technical documentation subsystem **186**. The stored documents are: parts catalogs, wiring and parts schematics, maintenance manuals, fault analysis pages, back shop manuals, field modifications instructions, training instructions, part identification animations, assembly animations, etc. The documentation includes both text, graphics, and visualization based documents. Thumbnail style summaries may be included with each document.

[0075] The files of the technical documentation subsystem **186** can be remotely browsed. That is, a user logged in to a network computer connected to the diagnosis and repair system **140**, but not necessarily the equipment hosting the

technical documentation subsystem **186**, can search for pages, view pages, follow links between pages, and copy pages to a local file.

[**0076**] The technical documentation subsystem **186** supports a search mechanism based on one or more of the following criteria: part name, part number, action name, fault code, locomotive model, and document type. Search results are presented in the form of a summation of the search results, with pointers to the actual pages so they can be retrieved on demand. The technical documentation subsystem **186** also supports the retrieval of individual document pages or document sections from its files. The retrieval process copies the retrieved pages to the user's application. The retrieval mechanism automatically adjusts hyperlinks between the copied pages accordingly.

[**0077**] The technical documentation subsystem **186** receives two types of inputs from the recommendation authoring system **182**. These include search criteria and search scope. Search criteria refers to one or more of the following: part name, part number, action name, fault code, or locomotive model number. The search scope refers to parts catalogs, maintenance manuals, schematics, back shop manuals, fault analysis pages, and field modification instructions.

[**0078**] The output from the technical documentation subsystem **186** is the list of all the technical documentation pages satisfying the search criteria. Each entry contains the following: the location of the page (for subsequent retrieval), the size of the file that makes up the page, the type of page (that is, the document source), and the locomotive road numbers to which the page applies. The recommendation authoring subsystem **182** can also access the technical documentation subsystem **186** for generalized browsing of the files. This feature allows a user to browse the documentation pages to determine the appropriate search criteria to use.

[**0079**] In one exemplary embodiment, the portable unit server **141** may use the following data concepts: specific recommendation directories, user identity files, portable unit status databases and home page files.

[**0080**] The recommendation directory is the location of web-deliverable, linked packages of repair instructions and technical documentation (including multimedia files) provided by the diagnosis and repair system **140** for each repair recommendation. This information is transferred to the portable unit server **141** and filed there. Each recommendation directory has a standard file format and architecture that allows the portable unit server **141** to read summary information about the repair recommendation.

[**0081**] Each repair home page begins with a summary of the repair steps and their corresponding feedback or data entry objects. From these original repair actions, the technician can drill down to more detailed information about the repair steps via links. In one embodiment, there is always a one-click path back to the original repair action from the deeper links. Once the repair step has been completed and appropriate feedback information obtained and recorded, the next step in the repair process is displayed, with links again to supporting documentation.

[**0082**] The user identity file, used by the portable unit server **141** as a data concept, contains names of all techni-

cians registered to use the portable units **14**. When a technician logs on, the identity entered in the log in box is checked against the identities stored in the portable unit server **141**. If the identification is not in the file, the technician is asked to re-enter the identification information. The portable unit server **141** also includes a portable unit status database containing information about the deployment of each portable unit **14**.

[**0083**] In one exemplary embodiment, each repair recommendation may have a structure that includes the following data: the recommendation identification number, the recommendation status, the technician identification number, the portable unit identification number, the log in time when the repair began, and the log out time when the repair was finished. Each repair recommendation has a file containing this information.

[**0084**] The last data element used by the portable unit server **141** is the home page list of recommendations. The home page list is the initial file displayed on the portable unit **14** when a technician logs on. The home page file includes a list of the currently active recommendations with: the locomotive road number, the repair technician identification number, the repair status, and a short description of the repair. A technician selects a specific recommendation from the home page file for transfer to his portable unit **14**, at which time the specific recommendation directory is transferred to the portable unit **14**. Whenever any data related to an active repair recommendation is changed, the home page file is automatically modified to reflect the change.

[**0085**] The repair status subsystem **184** (see **FIG. 7**) maintains and provides information on the status of each repair. Instantiating a repair recommendation triggers the creation of an entry in the locomotive history database **50** of the repair status subsystem **184**. The locomotive history database **50** is updated with data values collected by the data entry objects during a repair operation. Each repair entry in the locomotive history database **50** supports the following data items: repair case number, railroad case number, locomotive road number, the date the recommendation was issued, the rail yard where the repair was performed, and a list of the rail yard personnel who worked on the recommendation. Each repair entry also includes the data values collected with each step, the date the repair step was performed (as derived from the data collection process), and the current repair status (e.g., none, active, halted, or complete).

[**0086**] A new repair status entry is created in the repair records database **50** of the repair status subsystem **184** as follows. When a new recommendation is instantiated in the recommendation authoring subsystem, a summary is passed to the repair status subsystem **184**. This action triggers the creation of an entry in the repair records database **50** for the recommended repair. If a recommendation for a given case number is instantiated multiple times, the repair status subsystem **184** maintains the latest version of the recommendation. The repair status subsystem **184** maintains the most recent feedback irrespective of the version of the recommendation.

[**0087**] As discussed above, there is a considerable amount of technical documentation available to the technician using the portable unit **14**. The technician can navigate or search through the technical documentation by using wizard appli-

cations or visual drill downs. Additionally, the technical documentation includes on-line tutors that can be used to enhance the technician's understanding of the structure and function of the locomotive. The tutors are available in various levels of difficulty.

[0088] FIG. 8 is an exemplary flow chart illustrating an example of a trouble shooting wizard 251. More specifically, this flow chart illustrates the steps involved in checking one specific system, the Crankcase Over Pressure ("COP") 301, in a selected equipment, such as a locomotive 12. Once started, step 300, a decision gate, step 302, determines whether faults are logged. If faults are logged, then a locomotive repair technician, or user, will check engine oil level, step 304. The user will determine whether the engine oil level is overfull, step 306. If overfull, the user will drain the oil to the proper level, step 308. If not overfull, the user will check a sensor/device and replace if a defective Diagnostic Interactive Display (DID) panel pressure reading is detected, step 310. Next, the user will check for water in a crankcase and remove an oil fill cap to look for water or emulsified oil, step 312. The user will then determine whether water is in the oil, step 314. If water is in the oil, the user will pressure test the engine to identify water leaks, step 316. The user will then determine whether leaks are found, step 318. If leaks are found, the user will make repairs, step 320. The user will then apply a manometer to the crankcase and check vacuum/pressure, step 322. In a locomotive, as an exemplary example, this check is done at maximum throttle, such as notch 8 full horsepower. If faults are not logged, step 302, water is not found in the oil, step 314 or leaks are not found, step 318, the user will also apply the manometer to the crankcase and check vacuum pressure, step 322. The user will determine whether the pressure is greater than a given level, as an exemplary example is pressure greater than 0.24 inches of water column pressure, step 324. If not greater than the given level, the unit is released, step 326. If the pressure is greater, the user will inspect the crankcase eductor tubes and hoses for leaks or worn hoses, and inspect a muffler eductor tube for blockage or inner tube and remove, step 328. The user will then determine whether repairs are required, step 330. If required, the user will make repairs, step 332, and then repeat applying the manometer to the crankcase and check the vacuum pressure. If no repairs are required, the user will inspect a coalescer screen for proper application and verify that it is not plugged, step 334. The user will then determine whether repairs are required, step 336. If repairs are required, the user will make the repairs, step 332 and then apply the manometer to the crankcase again and check vacuum pressure, step 322. If repairs are not required, the user will inspect power assemblies for blow by into the crankcase, step 338. The user will then determine whether a blow by is found, step 340. If a blow by is found, the user will replace the defective power assemblies, step 342 and then again apply the manometer to the crankcase and check the vacuum pressure, step 322. If a blow by is not found, the user will consider that a turbo may have failed seals, step 344, and then inspect or replace the turbo, step 346. The user will then apply the manometer to the crankcase and check the vacuum pressure, step 322.

[0089] FIG. 9 shows a flow chart of a computerized method for guiding equipment service personnel while at an equipment site through a plurality of tasks for troubleshooting the health of a selected system of a selected equipment to determine the nature and extent of service needed. Sub-

sequent to start step 200, step 202 allows to provide a database comprising detailed data for health assessment and servicing of a selected equipment and system thereof, and an expert rule-based troubleshooting wizard for eliciting information regarding the selected equipment and system and for providing troubleshooting instructions to determine the nature of the equipment fault and the servicing required for the selected equipment and system. An input/output device for communicating with the database is provided, step 204. The method allows to select the equipment and the system thereof to be serviced, step 206. The method next provides, step 210, in response to a set of prompts to the personnel from the troubleshooting wizard at least one set of observations selected from the group comprising operational performance of the selected equipment, operational performance of the selected system, and fault indications detected in the equipment and system. The method then processes, step 212, the observation information relative to the troubleshooting wizard to determine whether or not the selected equipment and system needs to be serviced, and if so the nature and extent of that service.

[0090] FIG. 10 illustrates elements used in a computerized system for guiding equipment service personnel while at an equipment work site through a plurality of tasks for troubleshooting the health of a selected system of a selected equipment to determine the nature and extent of service needed for such a system. A database 250 is provided which comprises detailed data for health assessment and servicing of a selected equipment 12 and system 301 thereof. The database also includes an expert rule-based troubleshooting wizard 251 for eliciting information regarding the selected equipment and system and for providing troubleshooting instructions to determine the nature of the equipment fault and the servicing required for the selected equipment and system. An input/output device 252 is located at the work site for communicating with the database and in selecting the equipment and the system thereof to be serviced. A data management module 256 is provided for accessing the database to interface with the troubleshooting wizard for the selected equipment and system. The data management module 256 will supply, in response to a set of prompts to the personnel from the troubleshooting wizard, at least one set of observations selected from the group comprising operational performance of the selected equipment, operational performance of the selected system, and fault indications detected in the equipment and system. The system also includes a processor 260 configured to process the observation information relative to the troubleshooting wizard 251 to determine whether or not said selected equipment 12 and system 301 needs to be serviced, and if so the nature and extent of that service.

[0091] FIG. 11 illustrates an exemplary work-flow module 500 embodying aspects of the present invention to control various processes associated with implementing a repair or service recommendation. The first step of the work order module 500 is the development of a work scope at a step 502. The development of the work scope is influenced by certain tasks and processes input to a work order. For example, a repair recommendation 504, locomotive specific information 506, railroad specific information 508, field modification instructions and other recommendations requiring implementation 510 and an inspection wizard 512, the use of which may identify and add additional items to the work scope 502. The work scope information is input to a

work order backbone **520** for creating a work order to implement the various tasks associated with the work scope **502**. In preparing the work order, the cycle time associated with each task must be considered. Additionally, consideration must be given to sequencing available locomotives for repair. This information is also input to the work order backbone **520** from a step **522**. Factors that influence the repair schedule include material availability as indicated by a step **524** and the availability of other required resources, such as the availability of technicians to implement the repairs as indicated by the reference character **526**.

[**0092**] Following the sequencing step **522**, the work order is activated and execution of the repair initiated as indicated by a step **528**. The technician is directed during the execution of the repair through the portable unit **14** as discussed above. The information displayed on the portable unit **14** directs the step-by-step activities of the technician through the repair process including providing documentation and information from the various databases and modules discussed in conjunction with **FIG. 2**. With regard to **FIG. 8**, this information is indicated by a reference character **530**. The technician also utilizes maintenance troubleshooting wizards, identified by a reference character **532** during the repair process. Also as discussed above, data entry objects (feedback) are provided by the technician as the repair progresses. This information is shown as symbolically supplied to the work order backbone **520** and from there stored in a data warehouse **534**. Real time repair status information is provided from the work order backbone **520** to a monitoring board **535**, which may be located in the service shop **16** or at the service yard **13** for providing information on the status of the various in-process repairs. Further, information as to the repair processes can be supplied directly to a customer either in written form or transmitted electronically for display at a customer site, as shown by a reference character **536**. Additionally, the status information generated by the work order backbone **520** can be reviewed and used to improve the reliability of the various locomotive subsystems and further used to improve repair processes across all the service shops and service yards operated by the railroad. Communication of this status information across the railroad network can be efficiently accomplished via satellite communications, a land-based system or through a cellular telephone network.

[**0093**] While the invention has been described in what is presently considered to be a preferred embodiment, many variations and modifications will become apparent to those skilled in the art. Accordingly, it is intended that the invention not be limited to the specific illustrative embodiment but be interpreted within the full spirit and scope of the appended claims.

What is claimed is:

1. A computerized method for guiding equipment service personnel while at an equipment work site through a plurality of tasks for troubleshooting the health of a selected system of a selected equipment to determine the nature and extent of service needed for such system, said method comprising:

providing a database comprising detailed data for health assessment and servicing of a selected equipment and system thereof, and an expert rule-based troubleshooting wizard for eliciting information regarding the

selected equipment and system and for providing troubleshooting instructions to determine the nature of the equipment fault and the servicing required for the selected equipment and system;

providing an input/output device at the work site for communicating with the database;

selecting the equipment and the system thereof to be serviced;

accessing the database to interface with the troubleshooting wizard for the selected equipment and system;

providing in response to a set of prompts to the personnel from the troubleshooting wizard at least one set of observations selected from the group comprising operational performance of the selected equipment, operational performance of the selected system, and fault indications detected in the equipment and system; and

processing said observation information relative to the troubleshooting wizard to determine whether or not said selected equipment and system needs to be serviced, and if so the nature and extent of that service.

2. The method of claim 1 wherein the troubleshooting wizard is downloaded to the input/output device for performing the servicing activities.

3. The method of claim 1 wherein the input/output device communicates with the database after completion of the servicing activities to transfer information regarding the servicing of the selected equipment and system back to the database.

4. The method of claim 1 wherein the input/output device is in communication with the database during the servicing activities

5. The method of claim 1 wherein the input/output device interfaces with the troubleshooting wizard while the wizard is resident in the database.

6. The method of claim 1 wherein the input/output device is selected from the group comprising an Internet terminal, a computer terminal, a telephone and a radio transceiver.

7. The method of claim 1 wherein the input/output device communicates to the database via wireless communications.

8. A computerized system for guiding equipment service personnel while at an equipment work site through a plurality of tasks for troubleshooting the health of a selected system of a selected equipment to determine the nature and extent of service needed for such system, said system comprising:

a database comprising detailed data for health assessment and servicing of a selected equipment and system thereof, and an expert rule-based troubleshooting wizard for eliciting information regarding the selected equipment and system and for providing troubleshooting instructions to determine the nature of the equipment fault and the servicing required for the selected equipment and system;

an input/output device at the work site for communicating with the database and selecting the equipment and the system thereof to be serviced;

a data management module for accessing the database to interface with the troubleshooting wizard for the selected equipment and system and supply, in response

to a set of prompts to the personnel from the troubleshooting wizard, at least one set of observations selected from the group comprising operational performance of the selected equipment, operational performance of the selected system, and fault indications detected in the equipment and system; and

a processor configured to process said observation information relative to the troubleshooting wizard to determine whether or not said selected equipment and system needs to be serviced, and if so the nature and extent of that service.

9. The system of claim 8 wherein the input/output device communicates with the database after completion of the

servicing activities to transfer information regarding the servicing of the selected equipment and system back to the database.

10. The system of claim 8 wherein the input/output device is in communication with the database during the servicing activities

11. The system of claim 8 wherein the input/output device interfaces with the troubleshooting wizard while the wizard is resident in the database.

12. The system of claim 8 wherein the input/output device is selected from the group comprising an Internet terminal, a computer terminal, a telephone and a radio transceiver.

13. The system of claim 8 wherein the input/output device communicates to the database via wireless communications.

* * * * *