

(No Model.)

E. M. DART.
SELF LUBRICATING STOP COCK.

No. 522,515.

Patented July 3, 1894.

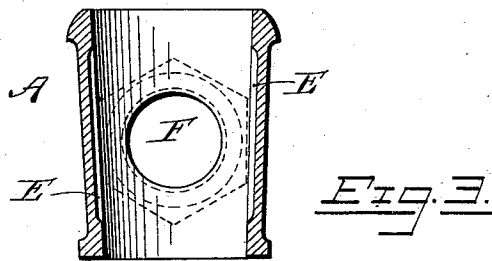
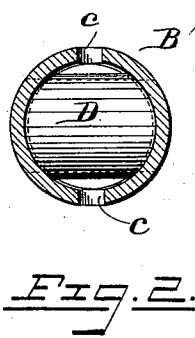
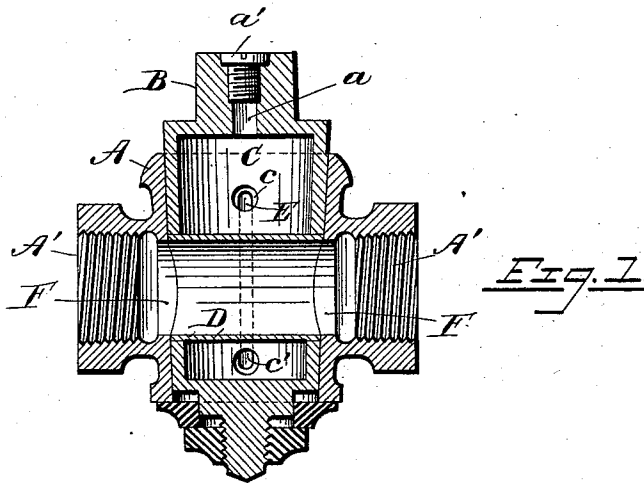

Witnesses.

Charles Hannigan
Wm L. Boyden

Inventor.

Edward M. Dart
By Frederick W. Vasker
Att'y.

UNITED STATES PATENT OFFICE.

EDWARD M. DART, OF PROVIDENCE, RHODE ISLAND.

SELF-LUBRICATING STOP-COCK.

SPECIFICATION forming part of Letters Patent No. 522,515, dated July 3, 1894.

Application filed February 15, 1893. Serial No. 462,430. (No model.)

To all whom it may concern:

Be it known that I, EDWARD M. DART, a citizen of the United States, residing at Providence, in the county of Providence and State of Rhode Island, have invented certain new and useful Improvements in Self-Lubricating Stop-Cocks; and I do hereby declare the following to be a full, clear, and exact description of the invention, such as will enable others skilled in the art to which it appertains to make and use the same.

This invention relates to an improvement in self-lubricating stop cocks, the object of the invention being to provide a simple, cheap, efficient and lasting stop cock adapted for various uses and the more particular object of the present invention is to improve upon or supplement in certain respects the stop cock described and claimed in my former patent, No. 464,727, dated December 8, 1891, and the invention therefore consists in the construction, arrangement and combination of parts, substantially as will be hereinafter described and claimed.

In the annexed drawings illustrating my invention: Figure 1 is a vertical section of my improved stop cock. Fig. 2 is a horizontal section of the plug. Fig. 3 is an enlarged vertical section of the shell, said section being taken at right angles to the section of Fig. 1.

Similar letters of reference designate corresponding parts throughout all the different figures of the drawings.

A designates the shell of my improved self-lubricating stop cock and B the rotative plug fitting closely and neatly therein within the seat which the shell provides for it. The rotative plug B may be of any suitable size and shape. It is provided with a large interior chamber extending from one end of the plug to the other, so that it is in fact simply a shell, being therefore light and requiring but little material for its construction.

C designates the interior chamber of the plug. The chamber C is adapted to contain a lubricant of any kind. The plug B is provided with a suitable number of lateral openings or perforations on the sides, preferably arranged opposite to each other and communicating with the interior chamber C. I preferably have two of these openings *c c* near the upper end of chamber C and two others

c' c' near the lower end of said chamber. It will be observed that these lateral openings *c c* and *c' c'* are closed exteriorly by the wall of the shell A. Said shell A is moreover provided with vertical grooves E E, of suitable size, as shown in Fig. 3, which grooves are cut on the inner face of the shell alongside of the plug B and are located diametrically opposite each other by the rotation of the plug B. The openings *c c* and *c' c'* will therefore at certain times be thrown into communication with the vertical grooves E E, the openings *c* connecting with the upper ends and the openings *c'* with the lower ends of these grooves, so that consequently at certain times the lubricant containing the chamber C will be placed in communication with the aforesaid vertical grooves or channels E E and also will at certain times be out of connection with said grooves, in other words it will be perceived that the grooves E E connect with the interior chamber C only at those intervals or times when the cock is open, and when the cock is closed they are out of communication with each other, because the lateral openings *c c* have been removed from proximity to the said grooves E. One set of openings *c* or *c'* may be dispensed with if desired.

The plug B is provided with a vertical passage *a* extending from the upper end of the plug and communicating with the lubricant-containing chamber C, said passage *a* being thus adapted to serve as an inlet opening through which lubricating material may be placed within the chamber C. The upper or outer end of the passage *a* is adapted to be closed by means of a screw cap or plug *a'*. After the lubricant has been placed within the chamber C and the plug B placed within the shell A and rotated to connect the lateral openings *c c'* with the grooves E E, the said grooves will become charged from the chamber C with a sufficient quantity of lubricant for each revolution of the plug B. The grooves E E will be replenished with lubricant each time they are brought in connection with the lateral openings *c c'* and when not rotated for a long time the parts will be effectually lubricated by the slower process of capillary attraction. The lateral openings *c c'* on each side of the plug B insure a free circulation of the lubricant either upward or

downward, the operation of which keeps the cock properly lubricated for a very long time.

The shell A commonly has the oppositely-seated nozzles A' A' to which pipes are connected in the ordinary manner. It is necessary of course that the steam, gas or other fluid or liquid, should have a passage through the plug B from the pipe on one side of shell A to the pipe on the other side thereof and in the ordinary solid plug it is customary for the same to have a transverse horizontal passage to permit of this. In the present case however of my plug having the large interior chamber as shown, the said transverse passage must be provided for in some other than the usual manner I accomplish this by forming openings, either round or other shape in the side walls of the plug B at points opposite to each other as at F F, see Fig. 3, and securing in these openings a horizontal section of pipe or tubing D. This tube D is open-ended and is secured tightly in the openings in the plug, by either swaging, brazing, soldering or in any other convenient manner. The tube D is so situated that it does not divide the interior chamber C into two parts and does not block or obstruct free passage from one end to the other of said chamber, because there is ample room on each side of the tube D, between it and the adjacent wall of the plug for the lubricating material to freely pass, as is clearly indicated in Fig. 2. Said tube D may be made of any suitable material and of any desired size.

The use, operation and object of the within-described stop cock will be clearly apparent from the foregoing description of its construction without need of any additional explanation. By making the stop-cock in the manner herein-described, it will be found that the same can be produced cheaply and that it will be as efficient as if made in the manner described in my aforesaid patent hereinabove alluded to, or in any other desired manner.

Numerous slight changes in the construction and adaptation of the parts may be made without varying from the plain intent and scope of the invention and I therefore reserve the liberty of making such slight changes as in actual practice may be found desirable.

Having thus described my invention, what I claim as new, and desire to secure by Letters Patent, is—

The herein-described stop cock, consisting of a shell which provides a seat for the plug, a plug formed as a shell and fitting closely therein, said plug having a lubricant-containing chamber extending entirely throughout the same so that the plug consists simply of a thin inclosing wall, said chamber having lateral openings on the sides of the plug which are closed by the wall of the surrounding shell, and said plug having also a top inlet opening communicating with the inner chamber through which lubricating material may be placed within the chamber, the horizontal pipe or tube secured tightly at its opposite ends in openings in the side walls of the plug so that the said tube may provide a transverse passage through the plug and the vertical grooves formed in the interior face of the wall of the shell and arranged to be in communication at their upper and lower ends with the lateral openings in the lubricant-containing chamber whenever the plug is opened but not in communication therewith when the plug is closed, the whole arranged so that the lubricating material within the chamber may spread itself by capillary attraction through the joints between the plug and the seat, substantially as described.

In testimony whereof I affix my signature in presence of two witnesses.

EDWARD M. DART.

Witnesses:

GEO. H. REMINGTON,
IDA M. WARREN.