

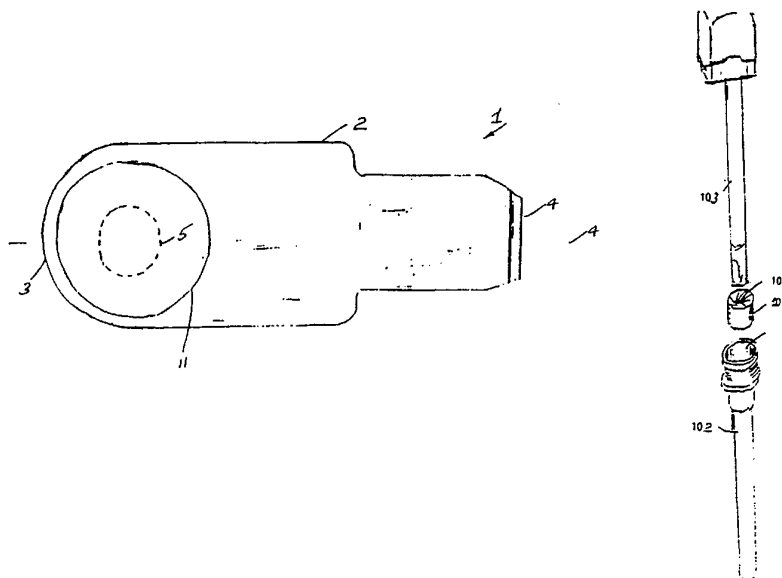

INTERNATIONAL APPLICATION PUBLISHED UNDER THE PATENT COOPERATION TREATY (PCT)

(51) International Patent Classification ⁶ : A61B 19/00	A2	(11) International Publication Number: WO 95/07056					
		(43) International Publication Date: 16 March 1995 (16.03.95)					
<p>(21) International Application Number: PCT/IE94/00045</p> <p>(22) International Filing Date: 6 September 1994 (06.09.94)</p> <p>(30) Priority Data:</p> <table border="0"> <tr> <td>930649</td> <td>6 September 1993 (06.09.93)</td> <td>IE</td> </tr> <tr> <td>930650</td> <td>6 September 1993 (06.09.93)</td> <td>IE</td> </tr> </table> <p>(71) Applicant (for all designated States except US): ENCORET LIMITED [IE/IE]; 17 Dame Street, Dublin 2 (IE).</p> <p>(72) Inventors; and</p> <p>(75) Inventors/Applicants (for US only): BONADIO, Frank [US/IE]; 2 Martello Terrace, Bray, County Wicklow (IE). LEAHY, Patrick [IE/IE]; Apartment 9, The Elms, Mount Merrion Avenue, Blackrock, County Dublin (IE).</p> <p>(74) Agent: MACLACHLAN & DONALDSON; 47 Merrion Square, Dublin 2 (IE).</p>	930649	6 September 1993 (06.09.93)	IE	930650	6 September 1993 (06.09.93)	IE	<p>(81) Designated States: AM, AT, AU, BB, BG, BR, BY, CA, CH, CN, CZ, DE, DK, EE, ES, FI, GB, GE, HU, JP, KE, KG, KP, KR, KZ, LK, LR, LT, LU, LV, MD, MG, MN, MW, NL, NO, NZ, PL, PT, RO, RU, SD, SE, SI, SK, TJ, TT, UA, US, UZ, VN, European patent (AT, BE, CH, DE, DK, ES, FR, GB, GR, IE, IT, LU, MC, NL, PT, SE), OAPI patent (BF, BJ, CF, CG, CI, CM, GA, GN, ML, MR, NE, SN, TD, TG), ARIPO patent (KE, MW, SD).</p> <p>Published <i>Without international search report and to be republished upon receipt of that report.</i></p>
930649	6 September 1993 (06.09.93)	IE					
930650	6 September 1993 (06.09.93)	IE					

(54) Title: APPARATUS FOR USE IN SURGERY AND A VALVE



(57) Abstract

Apparatus for use in surgery comprises a sleeve (1) having an entry opening (4) at an outer end and an exit opening (5) at an inner end to access a patient's body. Exit sealing means (10) are provided for sealing the exit opening (5) to a body. Entry sealing means (20) are provided for sealing the outer entry against an arm passing therethrough to create a controlled environment within the sleeve. A valve (101) comprises an outer ring (105, 106) and a sealing sleeve (107) of flexible material mounted to the ring (105, 106) and extending into the opening defined by the ring to terminate in a substantially centrally disposed inlet opening (108). Through the opening (108) a member such as a trocar (103) or surgical instrument may be passed. The sealing sleeve (107) remains in sealing engagement with the member (103) as it is passed therethrough.

FOR THE PURPOSES OF INFORMATION ONLY

Codes used to identify States party to the PCT on the front pages of pamphlets publishing international applications under the PCT.

AT	Austria	GB	United Kingdom	MR	Mauritania
AU	Australia	GE	Georgia	MW	Malawi
BB	Barbados	GN	Guinea	NE	Niger
BE	Belgium	GR	Greece	NL	Netherlands
BF	Burkina Faso	HU	Hungary	NO	Norway
BG	Bulgaria	IE	Ireland	NZ	New Zealand
BJ	Benin	IT	Italy	PL	Poland
BR	Brazil	JP	Japan	PT	Portugal
BY	Belarus	KE	Kenya	RO	Romania
CA	Canada	KG	Kyrgystan	RU	Russian Federation
CF	Central African Republic	KP	Democratic People's Republic of Korea	SD	Sudan
CG	Congo	KR	Republic of Korea	SE	Sweden
CH	Switzerland	KZ	Kazakhstan	SI	Slovenia
CI	Côte d'Ivoire	LI	Liechtenstein	SK	Slovakia
CM	Cameroon	LK	Sri Lanka	SN	Senegal
CN	China	LU	Luxembourg	TD	Chad
CS	Czechoslovakia	LV	Latvia	TG	Togo
CZ	Czech Republic	MC	Monaco	TJ	Tajikistan
DE	Germany	MD	Republic of Moldova	TT	Trinidad and Tobago
DK	Denmark	MG	Madagascar	UA	Ukraine
ES	Spain	ML	Mali	US	United States of America
FI	Finland	MN	Mongolia	UZ	Uzbekistan
FR	France			VN	Viet Nam
GA	Gabon				

- 1 -

APPARATUS FOR USE IN SURGERY AND A VALVE

5 The invention relates to an apparatus for use in surgery and in particular to an apparatus to be used in minimal invasive surgery in which surgery is carried out by making the minimum number of incisions in a patient's body.

The invention also relates to valve, and in particular to a valve for use with a trocar assembly.

10 Abdominal surgery is generally carried out by making a very large incision allowing a surgeon to enter the body cavity with both hands. Such surgery is traumatic for the patient and the healing process is lengthy. Some laproscopic surgery such as hernia operations may be carried out by surgeons using minimal invasive techniques with trocar assemblies. However, the techniques are
15 generally complex and difficult and are not widely used.

Trocars are short pointed instruments used to puncture a body cavity. A cannula may be inserted into the opening created by a trocar to drain the fluids from the body. Trocars may also be used during endoscopic procedures.
20 Trocar assemblies are described in U.S. 4,601,710 and 4,654,030.

Because of the wide range of instruments which pass through trocar tubes or trocar assemblies, a large variety of different diameter tubes and instruments are required.
25 Various attempts have been made to provide a valve to allow a range of different sizes of instruments to pass through a single trocar tube. These efforts to date however have not been entirely successful.

- 2 -

There is therefore a need for an improved valve particularly for a trocar tube or cannula which will overcome this problem. This invention is directed towards providing such a valve.

5 According to one aspect of the invention there is provided an apparatus for use in surgery comprising a sleeve having an entry opening at an outer end thereof and an exit opening at an inner end thereof to access a patient's body, exit sealing means being provided for sealing the exit
10 opening to a body and entry sealing means being provided for sealing the outer entry against an arm passing therethrough to create a controlled environment within the sleeve.

15 In a particularly preferred embodiment of the invention the sleeve is of a flexible material. Most preferably, the sleeve is of a gas-impermeable material to create a controlled pressurised environment within the sleeve.

In a particularly preferred embodiment of the invention the sleeve comprises a generally cylindrical body closed at one
20 end thereof and an exit opening is provided in a side wall of a body adjacent the closed end.

In one arrangement the exit sealing means comprises a flange around the exit for sealing against the body of a patient. Preferably the flange is provided with an adhesive for adhering to the body. Typically the exit and
25 flange are covered by a peel-off cover.

- 3 -

In another arrangement the flange is engaged with a mounting ring surrounding an incision in a patient's body.

The entry sealing means may comprise a valve means through which a surgeon passes an arm. Preferably the valve means is of a material which is sufficiently flexible to allow an arm to be passed therethrough and to seal against the arm when passed therethrough.

Alternatively, the means comprises a first mounting in the sleeve entry, a second mounting and a sealing body of flexible material extending between the mountings, one of the mountings being twisted relative to the other two to twist the sealing body into engagement with an arm passing therethrough.

In one arrangement fixing means are provided for fixing one mounting relative to the other in the sealing position. Typically the fixing means comprises inter-engaging formations provided on the mountings.

In another arrangement the first mounting comprises a ring mounted in the sleeve at the entry thereof

In a particularly preferred arrangement the second mounting comprises a ring to which the sealing material is attached.

In one embodiment of the invention the entry sealing means comprises a first sealing element provided in the entry and a second sealing entry provided on a surgical glove, the sealing elements inter-engaging to seal the sleeve on passing of the glove through the entry.

According to another aspect of the invention there is provided a valve comprising an outer ring and a sealing sleeve of flexible material mounted to the ring and extending into the opening defined by the ring to terminate
5 in a substantially centrally disposed inlet opening through which a member such as a trocar or surgical instrument may be passed, the sealing body remaining in sealing engagement with the member as it is passed therethrough.

10 In a particularly preferred embodiment of the invention, the sealing body is twisted into a substantially hourglass shape having a central opening through which a member is passed.

15 Preferably the ring comprises a pair of axially facing ring parts, opposite free ends of the flexible sealing sleeve being attached to the respect ring parts, one of the ring parts being rotated relative to the other to twist the
20 sealing sleeve into a twisted sealing configuration and fixed relative to the other ring part in the sealing configuration.

The invention also provides a trocar tube or cannula
25 incorporating a valve according to the invention.

The invention further provides a trocar assembly incorporating a trocar tube or cannula according to the invention and/or a valve according to the invention.
30

35

The invention will be more clearly understood from the following description thereof, given by way of example only with reference to the accompanying drawings in which:-

- 5 Fig. 1 is a plan view of a sleeve;
- Fig. 2 is a cross-sectional view of the sleeve of Fig. 1;
- Fig. 3 is a plan view of a sleeve with an entry sealing means in position;
- 10 Fig. 4 is a perspective view of the sleeve of Fig. 3 in use;
- Fig. 5 is a perspective view of the entry sealing means used in the sleeve of Figs. 3 and 4 in an open configuration;
- 15 Fig. 6 is a side elevational view of the sealing means of Fig. 5 in an intermediate position;
- Fig. 7 is a perspective view of the sealing means of Fig. 5 in a sealed configuration;
- 20 Fig. 8 is a perspective view of another sleeve according to the invention; and
- Fig. 9 is a side cross-sectional view of a further sleeve according to the invention.

- 6 -

Fig. 10 is a side cross-sectional view of one further sleeve according to the invention and

Fig. 10a is a rear end view of the sleeve shown in Fig. 10;

5 Fig. 11 is a diagrammatic exploded perspective view of a trocar assembly incorporating a valve according to the invention;

Fig. 12 is a cross sectional view of a valve used in the assembly of Fig. 1;

10 Fig. 13 is a perspective view of a trocar tube incorporating the valve;

Fig. 14 is a cross sectional view of the trocar and valve in use;

Fig. 15 is a cross sectional view of a modified arrangement according to the invention in one position of use; and

15 Fig. 16 is a cross sectional view of the arrangement of Fig. 15 in another position of use.

- 7 -

Referring to the drawings and initially to Figs. 1 to 7 thereof, there is illustrated an apparatus for use in surgery according to the invention indicated generally by the reference numeral 1. The apparatus 1 comprises a sleeve 2 of flexible gas-impermeable material. The sleeve 2 in this case comprises a generally cylindrical body closed at one end 3 thereof and open at the other end 4 thereof to define an entry opening at an outer end for passage of an instrument and/or surgeon's arm. An exit opening 5 is provided in a side wall of the sleeve 2 as illustrated particularly in Fig. 2 to provide an access point for entering a patient's body through an incision therein.

Exit sealing means 10 for sealing the exit opening 5 to a patient's body is in this case provided by a flange 11 around the exit opening 5 to the outer face of which is applied a pressure sensitive adhesive for adhering to the body of the patient. The adhesive side of the flange 11 is covered prior to use with a peel-off cover 12.

Entry sealing means which for clarity is not illustrated in Figs. 1 and 2 is in this case provided by a valve means indicated generally by the reference numeral 20 and illustrated particularly in Figs. 3 to 7. The valve means 20 comprises a first mounting provided by a ring 21 attached to the body of the sleeve 2 at the entry 4 and a second mounting provided by another ring 22 which is attached to the first ring 21 by a sealing member 23 of flexible material extending between the rings.

The outer ring 22 with the flexible body 23 attached is rotated to twist the sealing body 23 in the direction of the arrow X illustrated in Fig. 6 to engage and seal against a surgeon's arm 30 passing therethrough. When the sealing member 23 is in sealing engagement the outer ring

- 8 -

22 is pushed forwardly in the direction of the arrow Y against the inner ring 21 and the rings are engaged together to maintain the sealing engagement.

Fixing means for preventing rotation of the rings 21, 22 relative to one another when the rings are in the sealing position illustrated in Fig. 7 is in this case provided by a plurality of projections 27 on one of the rings 22 which are engageable with a plurality of complimentary shaped recesses 28 in the other rings 21 to lock the rings 21, 22 against rotation in the sealing position.

In use, an incision is first made in a patient 31. The cover 11 is then removed and the flange 12 is adhesively bonded to the patient around the incision as illustrated particularly in Fig. 4. The sleeve is arranged so that the exit opening 5 is aligned with the incision in the patient 31. With the entry sealing means 20 in the open non-sealing configuration illustrated in Figs. 3 and 5 a surgeon passes his hand and arm 30 through the entry 4 and the exit opening 5 to enter the patient's body through the incision. When the surgeon's arm 30 has passed through the sealing means 20 a desired distance, the outer ring 22 with the sealing body 23 attached is rotated to twist the sealing body 23 to engage against the surgeon's arm 30 until a relatively tight seal is obtained. The ring 22 is then pushed forwardly against the ring 21 and the projections are engaged in the recesses 28 to lock the rings 21, 22 together against rotation in the sealing configuration. In the case of bowel re-section surgery, gas is pumped into the patient's body cavity where the surgery is to be performed, the gas exiting through the incision in the patient and the opening 5 into the sleeve 2 to create a controlled pressurised environment in the sleeve 2 in which the sleeve 2 is inflated. The surgeon carries out the surgery as required and when completed the

- 9 -

ring 22 is released from the ring 21 and contra-rotated until the flexible body 23 is in the non sealing position allowing the surgeon to extract his hand through the sleeve 2.

5 There are many advantages of the invention. Because a surgeon need only make a relatively small incision the trauma to the patient is minimised, there is less risk of damage to the immune system and the healing time is short with a consequent decrease in the length of the hospital
10 stay required. The techniques are considerably simpler than conventional laproscopic surgical techniques and can be readily performed by a surgeon with minimal additional training. A wide range of operations can be performed using the apparatus of the invention.

15 Referring to Fig. 8 there is illustrated another apparatus for use in surgery according to the invention indicated generally by the reference numeral 50. The apparatus 50 is similar to the apparatus described above with reference to Figs. 1 to 4 and like parts are assigned the same
20 reference numerals. In this case the entry sealing means comprises a first ring 51 mounted to the sleeve 2 at the entry 4 and a second separate ring 52 at the free end of a surgical glove 53. When a surgeon's arm with the glove 53 passes through the entry 5 the rings 51, 52 are
25 arranged to sealingly engage to create a controlled environment within the sleeve 2 during an operation.

Referring to Fig. 9 there is illustrated a further apparatus according to the invention for use in surgery and indicated generally by the reference numeral 60. In
30 this case, the exit sealing means comprises a sealing diaphragm having a first ring 61 attached to the sleeve 2 and a flexible diaphragm 62 extending from the ring 61 and terminating in an inner ring 63 which is inserted

- 10 -

through the incision to engage with the body tissue 30 as illustrated. The sealing diaphragm seals the exit 5 of the sleeve 2 to the incision in the patient's body to create a controlled pressurised environment in the sleeve 2.

5 With reference to Figs. 10 and 10a, the sleeve 70 is an impermeable and flexible sleeve, one end of which is configured to provide a pressure tight seal against a surgeons forearm with the other end configured to provide a pressure tight seal with a patients skin. With the sleeve
10 70, and integral with it, is a non-return valve 74, in the form of a sealing cuff, permitting the removal of a surgeons hand and forearm from the sleeve whilst maintaining pressure within a patients abdomen.

The sleeve 70, in overall shape and method of construction,
15 is substantially equivalent to known colostomy bags, differing in that its overall length is greater, there is the integral non-return valve 74 and the open end permits attachment to a surgeons forearm. The sleeve comprises two layers of medical grade polyethylene, one with an
20 orifice 71, edge welded using a radio frequency (RF) welding technique. An annular flange 72 of medical grade polyethelene, one surface of which is coated with medical grade adhesive, is welded to the sleeve as shown. The non-return valve 74 comprises two layers of medical grade
25 polyethelene welded to the sleeve to form the valve indicated. The arm attachment device consists of two rigid medical grade polyethelene circular members 76,77 connected, as indicated, by a thin walled cylindrical tube 78 of elastomer (medical grade latex or similar).
30 Rotation of member 76 relative to 77 causes the latex tube to form an iris diaphragm effectively reducing the size of the arm access opening. Attachment of member 77 to the

- 11 -

sleeve is achieved using medical grade adhesive.

5 The technique of attachment of this device to a patient is similar to that of a colostomy bag. The annular, adhesive coated flange is applied to a patients skin such that the annulus encircles the access incision. Adhesion may be assisted by the application of an adhesive surgical drape prior to making said incision. Attachment to a surgeons forearm is achieved by inserting a hand and forearm into the sleeve through member 76. Rotation of member 76 relative to member 77 causes an iris diaphragm to form effectively gripping the forearm with the elastomer sleeve. Further movement of the hand towards opening 71 causes the non-return valve 74 to open and access to the abdominal cavity is possible through the access incision. Removal of a surgeons hand is in the reverse order to that above with the result that the non-return valve 74 closes maintaining abdominal pressure.

20 It is anticipated that in some cases adhesive may be applied to a patient around the area of an incision to which a sealing ring of the sleeve is to be attached during preparations for an operation. Adhesive may alternatively or additionally be applied to the ring to be attached around the area of an incision. Either or both layers of adhesive may be covered by a sterile wrapping material through which the incision may be made. Either or both layers of adhesive may be provided with peel off covers.

30 It will further be appreciated that the sleeve may incorporate an air lock to facilitate changing of an instrument and/or debris such as cancer cells during an operation without breaking the sterilised environment in the sleeve.

35

The sleeve may be provided with more than one inlet opening for a surgeon's arms and/or instruments.

5 The sleeve may also be provided with means to create an intermediate pressurised environment by, for example, providing two inlet sealing cuffs spaced-apart along the sleeve. The inner of the cuffs being sealed before the seal provided by the outer cuff is opened.

10 Referring to Figs. 11 to 16, and initially to Figs. 11 and 12 there is illustrated a valve according to the invention indicated generally by the reference numeral 101 which in this case is used in association with a trocar assembly comprising a trocar tube or cannula 102 and a trocar 103.

15 The valve 101 comprises an outer ring which in this case comprises a pair of axially facing ring 105, 106 and a sealing sleeve 107 of a flexible material, the free ends 107a, 107b of which are attached to the respective ring parts 105, 106.

20 To form the valve 101 according to the invention, typically one of the ring parts 105 is rotated relative to the other to twist the flexible sleeve 106 from a substantially cylindrical non-sealing configuration to an hourglass sealing configuration as illustrated particularly in Fig. 12 having a central opening 108 through which a member such as a trocar 103 may be inserted. The ring parts 104, 106 are
25 retained in the sealing configuration illustrated in Fig. 12 by any suitable means such as by adhesive bonding or the like.

30 The valve 101 is typically housed in a seat 109 of a trocar tube or cannula 102. To pass a member such as a trocar 103, operating instrument 110 or the like through the valve 101 in a trocar tube or cannula 102, the trocar 103 is first offered up to the opening 108 in the sealing sleeve 107 and is pushed through the sleeve 107 by rotating the trocar 103 to ease the

- 13 -

passage of the trocar through the sleeve by contra-rotating the sealing sleeve 107 against the sealing twist to enlarge the opening 108. As the trocar 103 passes through the sleeve 108 the sealing engagement is maintained.

5 A wide range of different size and types of members such as trocars or operating instruments may be readily passed through a single valve 101. For narrow members such as the instrument 110 illustrated in Figs. 15 and 16 a collar 115 may be provided around the instrument 110, the collar 115
10 engaging against the sealing sleeve 107 of the valve 101 to enlarge the opening 108 (see Fig. 5) allowing the collar 115 and instrument 110 to readily pass therethrough (Fig. 16). In the inserted position a shoulder 116 of the collar 115 engages against a stop 117 on the tube 102. When it is
15 desired to withdraw the instrument 10 from the trocar tube 102, the instrument is drawn back to the collar 115 and the collar 115 with the instrument 110 in frictional engagement therewith is drawn back through the flexible sealing sleeve 107.

20 There are many advantages of the valve according to the invention. For the particular surgical application described, a single trocar tube may now be inserted into a body cavity allowing a wide range of different types and sizes of instruments to be inserted through the tube.
25 Thus, there would be a reduction in the number of trocar assemblies required for a particular operation. In addition, because of the simplicity of construction and operation, the valve and trocar tube or cannula are readily sterilisable and consequently re-usable.

30 It will be appreciated that while the invention has been specifically described for use with a trocar assembly, it has many different applications and accordingly the

invention is not limited to the application of the valve to a trocar tube, cannula or trocar assembly.

5 It will be appreciated that an additional entry aid may be provided as an alternative to or in addition to the collar just described. The additional sealing may be provided by a plurality of flexible segments extending inwardly on the inlet side of the valve, the segments being pushed forwardly on insertion of an instrument to engage against and open the valve to facilitate passage through the
10 valve.

The invention is not limited to the embodiments hereinbefore described, which may be varied in construction and detail. without departing from the scope of the invention as defined in the appended Claims 1 to 24 which are incorporated in this description by reference.

CLAIMS:

1. Apparatus for use in surgery comprising a sleeve having an entry opening at an outer end thereof and an exit opening at an inner end thereof to access a patient's body, exit sealing means being provided for sealing the exit opening to a body and entry sealing means being provided for sealing the outer entry against an arm passing therethrough to create a controlled environment within the sleeve.
5
2. Apparatus as claimed in Claim 1 wherein the sleeve is of a flexible material.
10
3. Apparatus as claimed in Claim 1 or 2 wherein the sleeve is of a gas-impermeable material to create controlled pressurised environment within the sleeve.
15
4. Apparatus as claimed in any preceding claim wherein the sleeve comprises a generally cylindrical body closed at one end thereof and an exit opening is provided in a side wall of a body adjacent the closed end.
20
5. Apparatus as claimed in any preceding claim wherein the exit sealing means comprises a flange around the exit for sealing against the body of a patient.
25
6. Apparatus as claimed in Claim 5 wherein the flange is provided with an adhesive for adhering to the body.

- 16 -

7. Apparatus as claimed in Claim 5 or 6 wherein the exit and flange are covered by a peel-off cover.
8. Apparatus as claimed in Claim 5 wherein the flange is engaged with a mounting ring surrounding an incision in a patient's body.
5
9. Apparatus as claimed in any preceding claim wherein the entry sealing means comprises a valve means through which a surgeon passes an arm.
10. Apparatus as claimed in Claim 9 wherein the valve means is of a material which is sufficiently flexible to allow an arm to be passed therethrough and to seal against the arm when passed therethrough.
10
11. Apparatus as claimed in Claim 9 wherein the valve means comprises a first mounting in the sleeve entry, a second mounting and a sealing body of flexible material extending between the mountings, one of the mountings being twisted relative to the other to twist the sealing body into engagement with an arm passing therethrough.
15
20
12. Apparatus as claimed in Claim 11 wherein fixing means are provided for fixing one mounting relative to the other in the sealing position.
13. Apparatus as claimed in Claim 12 wherein the fixing means comprises inter-engaging formations provided on the mountings.
25
14. Apparatus as claimed in any of Claims 11 to 13 wherein the first mounting comprises a ring mounted in the sleeve at the entry thereof.

15. Apparatus as claimed in Claim 14 wherein the second mounting comprises a ring to which the sealing material is attached.
- 5 16. Apparatus as claimed in any of Claims 1 to 8 wherein the entry sealing means comprises a first sealing element provided in the entry and a second sealing entry provided on a surgical glove, the sealing elements inter-engaging to seal the sleeve on passing of the glove through the entry.
- 10 17. An apparatus as claimed in claim 1, wherein said sleeve includes at least one additional entry opening which permits another arm or an instrument to be passed into the sleeve while said entry opening has an arm positioned therein.
- 15 18. An apparatus as claimed in claim 1, wherein said sleeve is provided with a sealing cuff disposed between said entry and exit openings for substantially sealing the sleeve when said entry opening is in an open condition.
- 20 19. An apparatus for being secured to a patient's body to provide a sealed passage into the interior of the body, the apparatus permitting the arm or fingers of a physician to be passed therethrough, said apparatus comprising:
- a sleeve member having first and second ends, an entry opening formed in said first end and an exit opening formed in said second end;
- 25 said first end having sealing means adjacent said entry opening for substantially sealing the first end against the physician's arm when a portion of the arm is positioned in an interior of said sleeve; and

said second end having attachment means for attaching the second end of said sleeve to said body with said exit opening being positioned adjacent an incision formed in said body, said attachment means being capable of substantially sealing said second end to said body;

whereby said apparatus is attachable to said body with the exit opening adjacent said incision, and the physician's arm can be positioned in said sleeve with the entry opening substantially sealed therearound such that the apparatus provides passage into the interior of the body to permit the surgeon to reach into said interior of the body to perform a surgical procedure.

20. A method of performing a minimally invasive medical procedure utilizing an apparatus which permits at least a portion of a physician's hand to pass into a patient's body through an incision in the body, the method comprising the steps of:

(a) making an incision in the patient's body;

(b) providing an apparatus in the form of a sleeve having opposite ends and an opening in each of said ends, one of said ends configured for attachment to the body and an other of said ends configured for receiving a portion of the physician's arm;

(c) attaching said one end of the sleeve to the body so as to surround the incision with said one end in substantially sealing contact against the body;

(d) the physician passing said hand and arm portion through said other end of the sleeve with said other end in substantially sealing contact against said arm portion; and

(e) the physician inserting said hand through the
5 incision and into the interior of said body to perform a
medical procedure.

21. A valve comprising an outer ring and a sealing sleeve of flexible material mounted to the ring and extending into the opening defined by the ring to terminate in a substantially centrally disposed
10 inlet opening through which a member such as a trocar or surgical instrument may be passed, the sealing body remaining in sealing engagement with the member as it is passed therethrough.

15 22. A valve as claimed in Claim 2 wherein the sealing body is twisted into a substantially hourglass shape having a central opening through which a member is passed.

20 23. A valve as claimed in Claim 1 or 2 wherein the ring comprises a pair of axially facing ring parts, opposite free ends of the flexible sealing sleeve being attached to the respective ring parts, one of the ring parts being rotated relative to the other to twist the sealing sleeve into a twisted sealing configuration and fixed
25 relative to the other ring part in the sealing configuration.

24. A trocar tube or cannula incorporating a valve as claimed in any preceding claims 21 to 23.

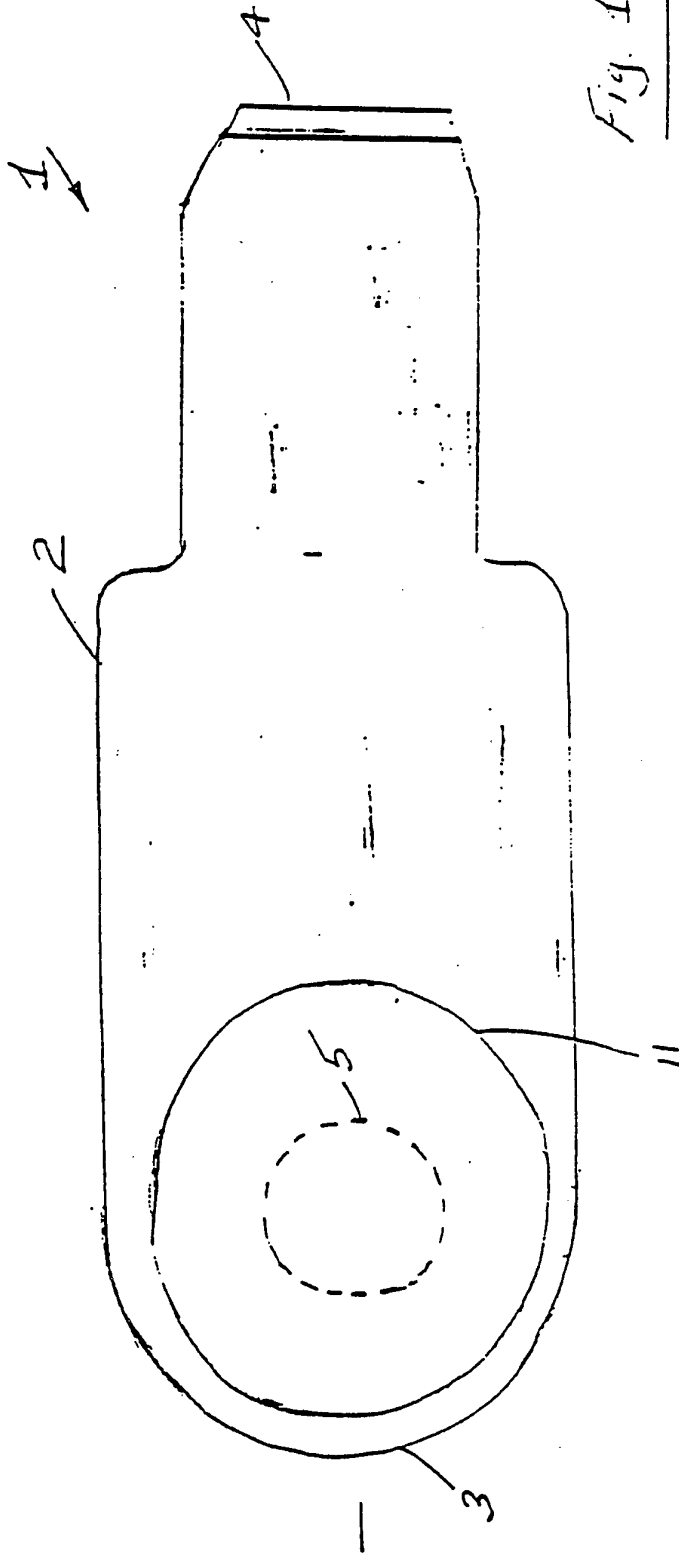

Fig. 1

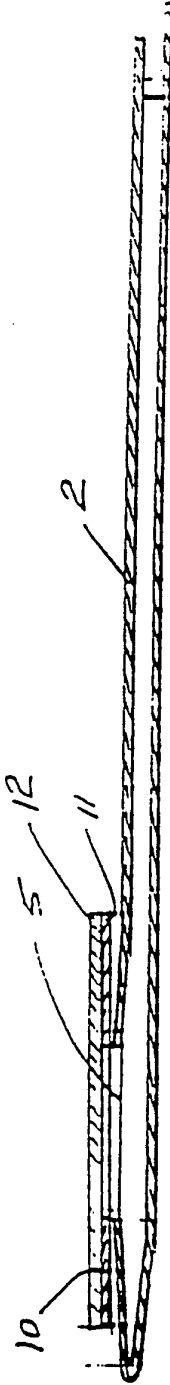

Fig. 2

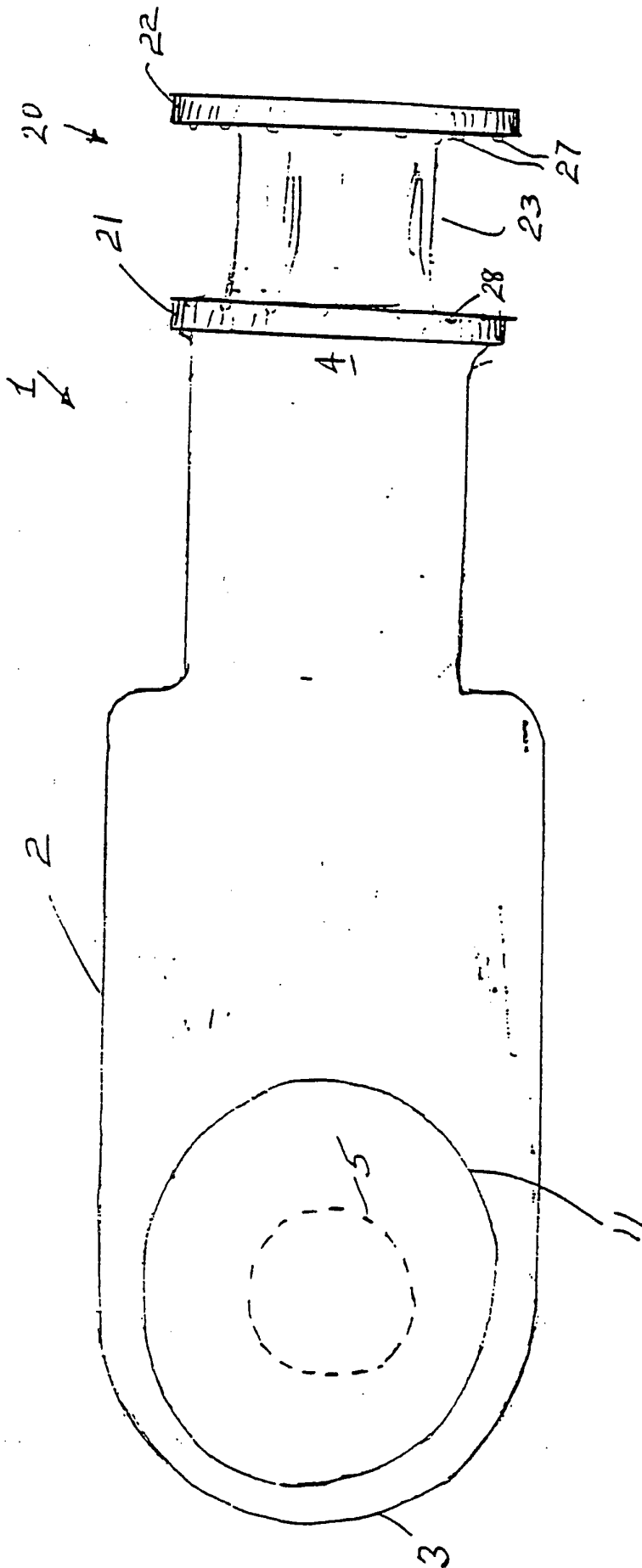

Fig. 3

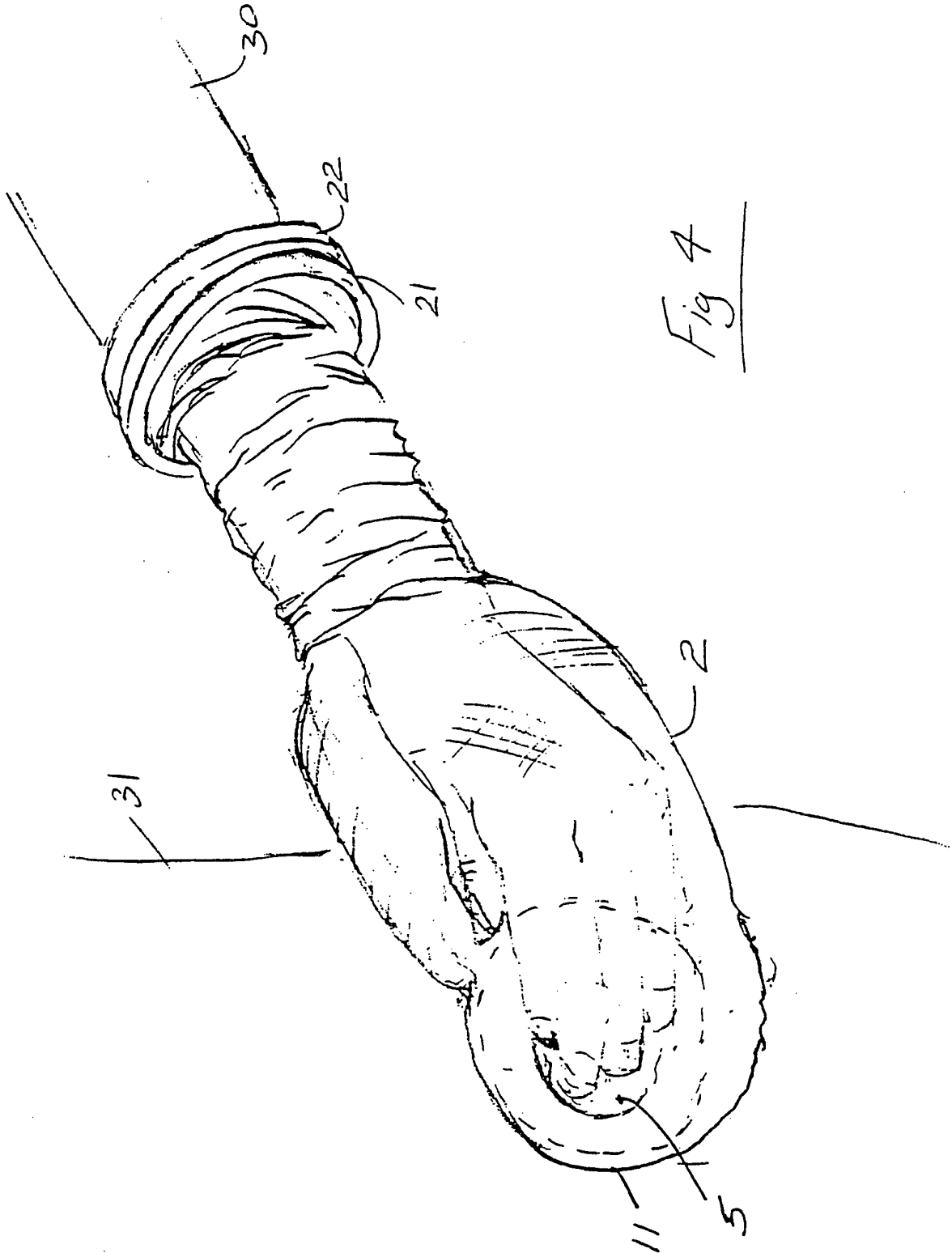

Fig 4

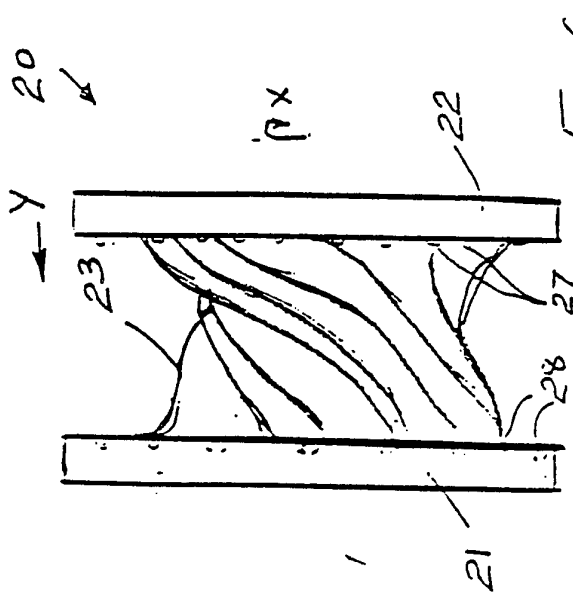

Fig 6

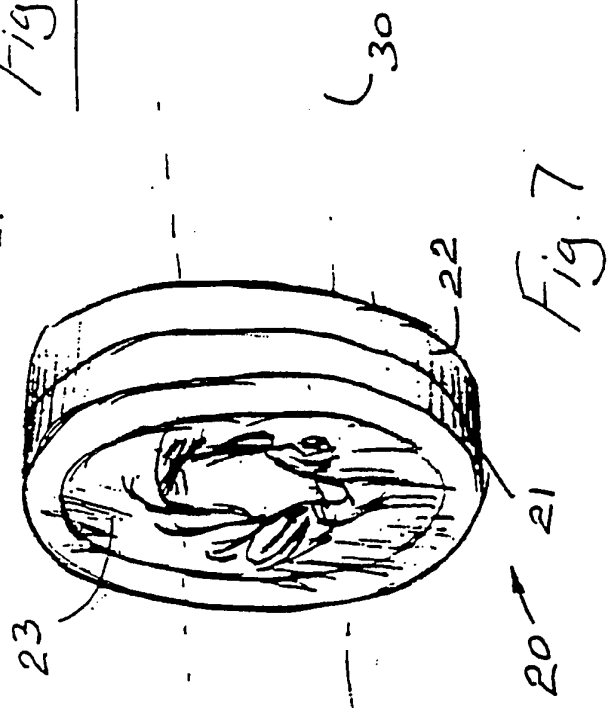

Fig. 7

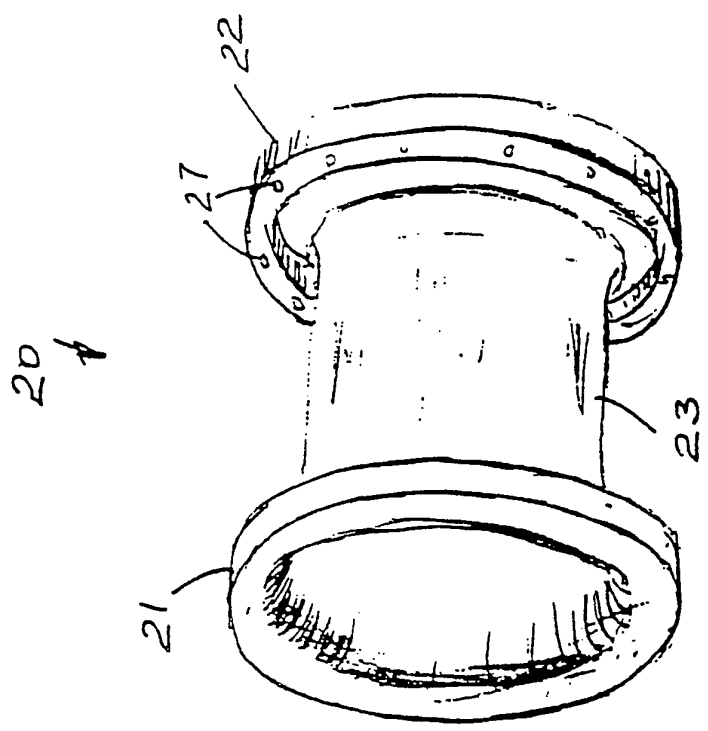

Fig. 5

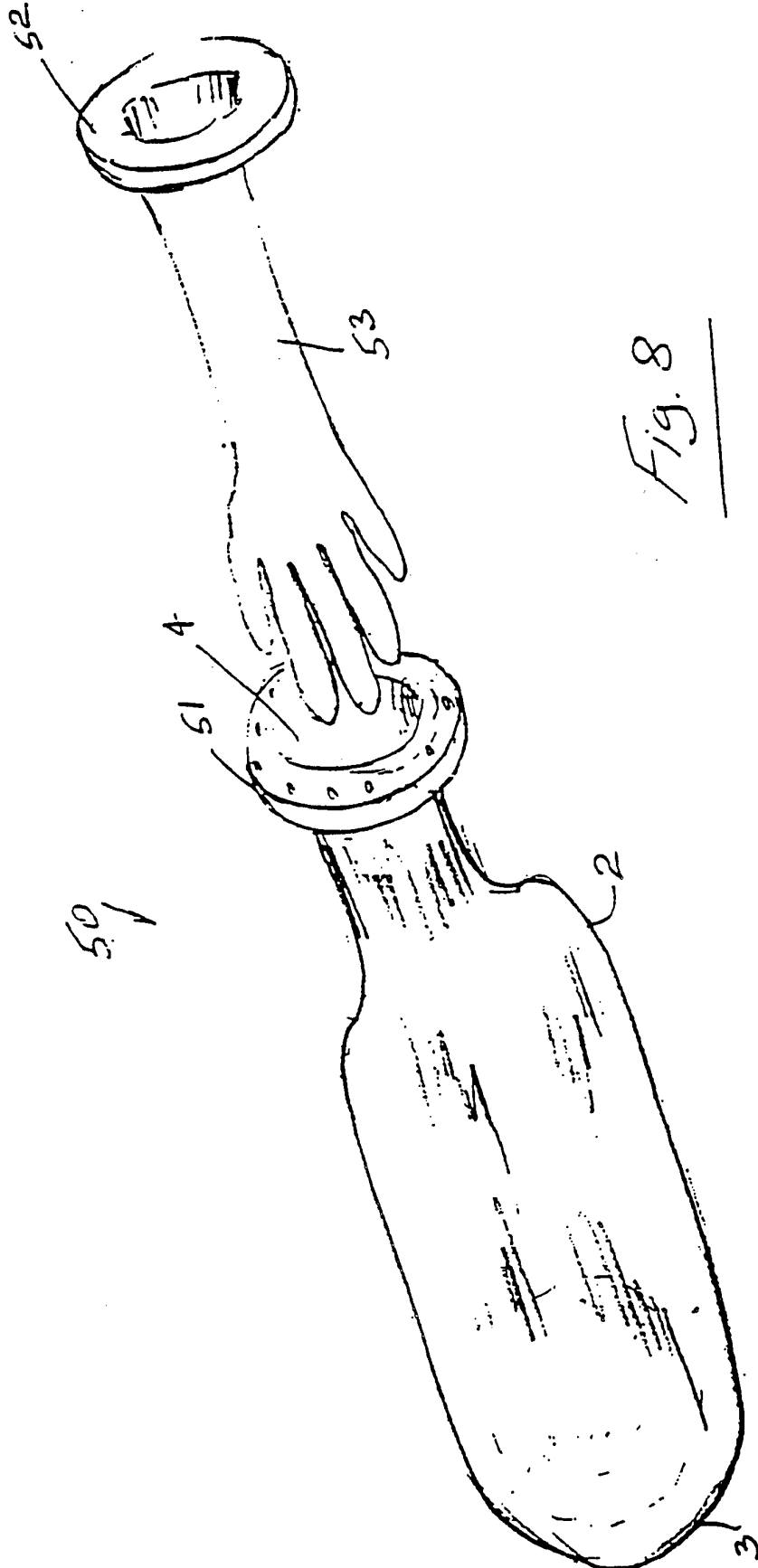

Fig. 8

6/9

60

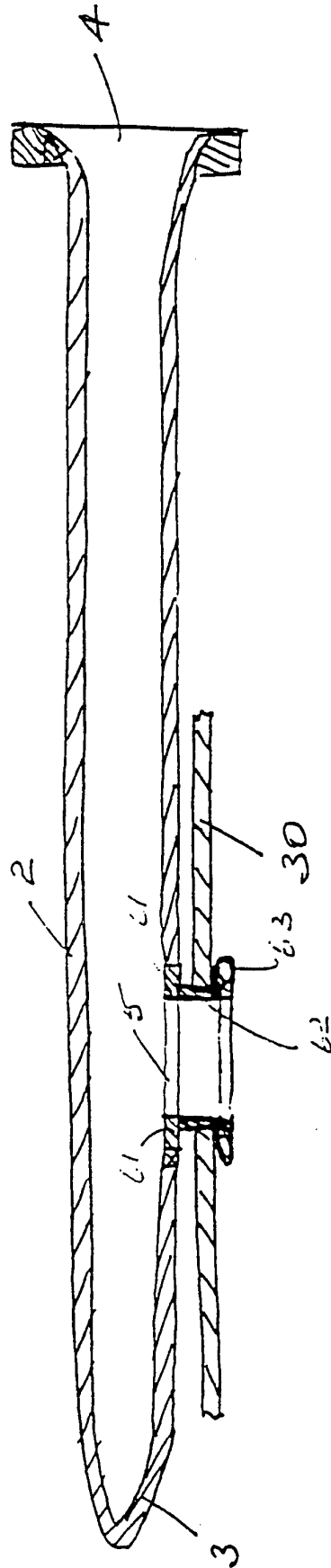

Fig. 9

7/9

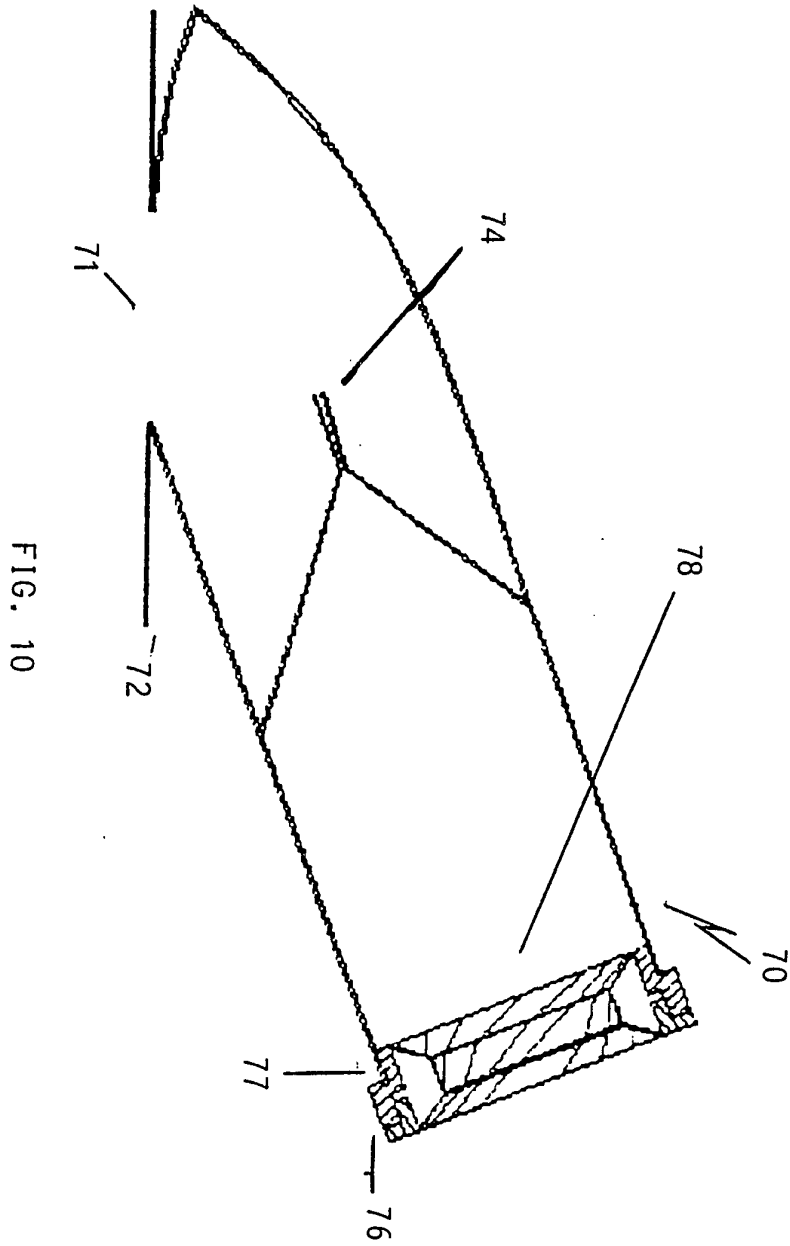
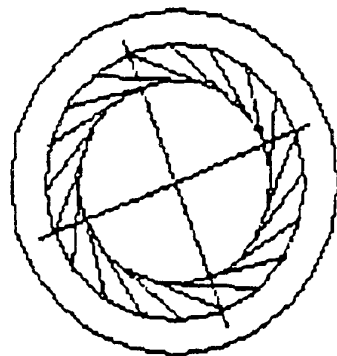

FIG. 10a



8/9

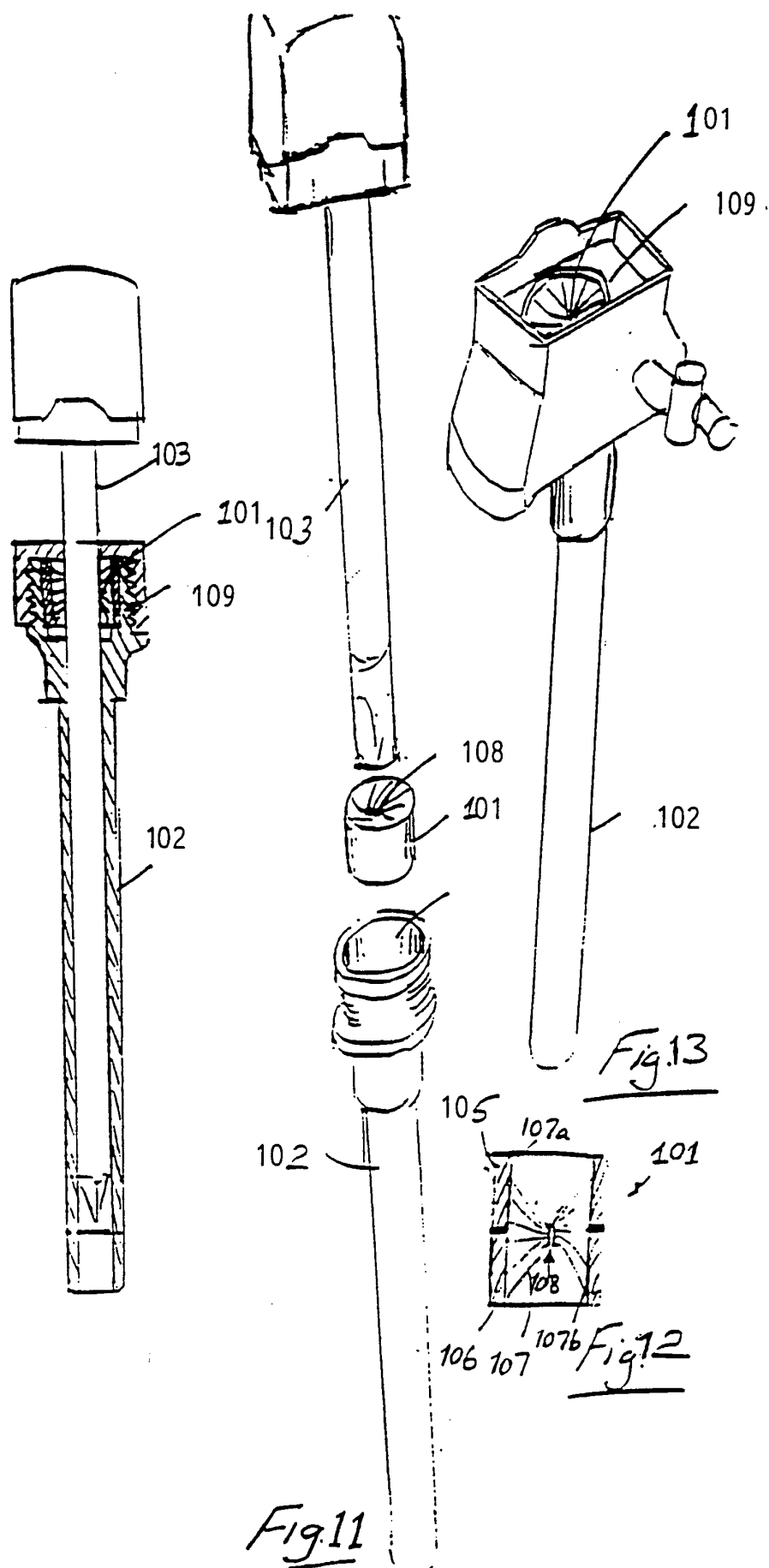

Fig. 14

Fig. 13

Fig. 12

Fig. 11

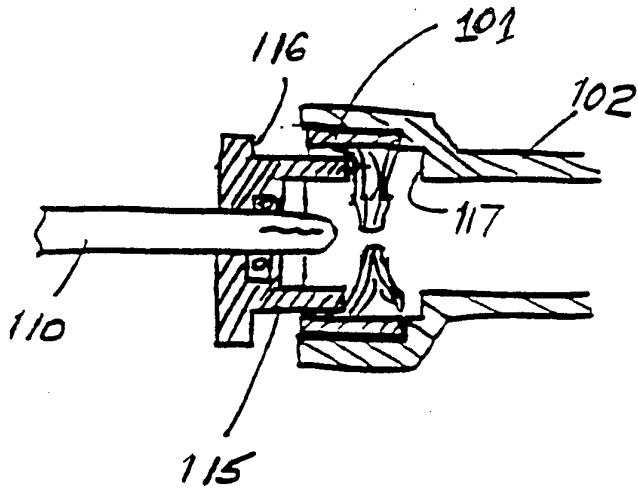

Fig. 15

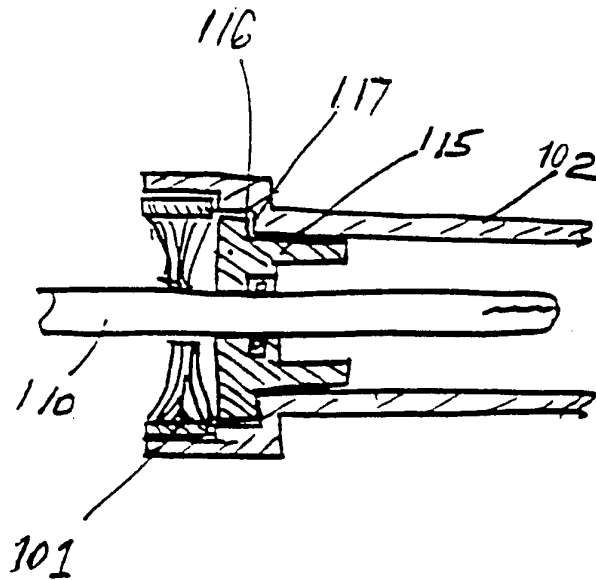

Fig. 16