



US 20050246814A1

(19) **United States**

(12) **Patent Application Publication**  
**Cooper et al.**

(10) **Pub. No.: US 2005/0246814 A1**

(43) **Pub. Date: Nov. 10, 2005**

(54) **HUG-ME-TIGHT**

**Related U.S. Application Data**

(76) Inventors: **Jennifer Lovette-Cephus Cooper**, Park Forest, IL (US); **Dawn Yates-Mims Cooper**, Park Forest, IL (US)

(60) Provisional application No. 60/557,124, filed on Mar. 29, 2004.

**Publication Classification**

Correspondence Address:  
**JENNIFER LOVETTE-CEPHUS**  
**156 ALGONQUIN ST.**  
**PARK FOREST, IL 60466 (US)**

(51) **Int. Cl.<sup>7</sup>** ..... **A63H 3/00**; A41B 9/00;  
A41B 13/08

(52) **U.S. Cl.** ..... **2/111**

(21) Appl. No.: **11/087,749**

(57) **ABSTRACT**

(22) Filed: **Mar. 24, 2005**

The HUG-ME-TIGHT restructured the papoose style wrap to a more convenient and simplified form of infant wrap.

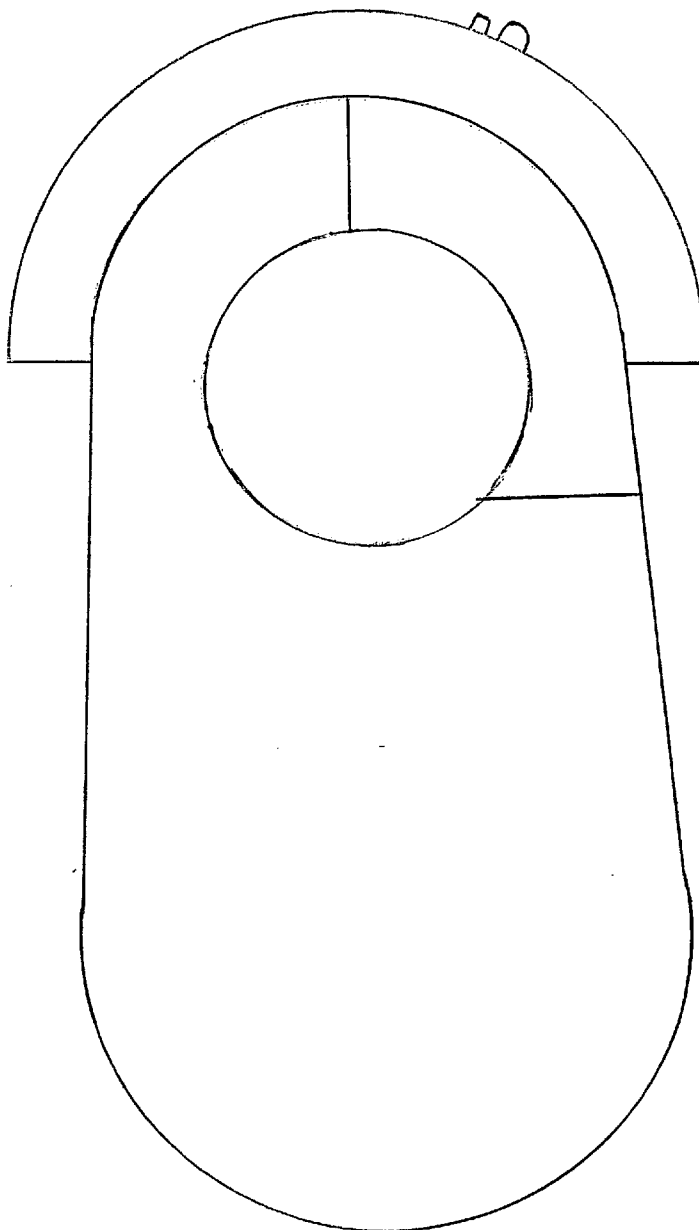

A

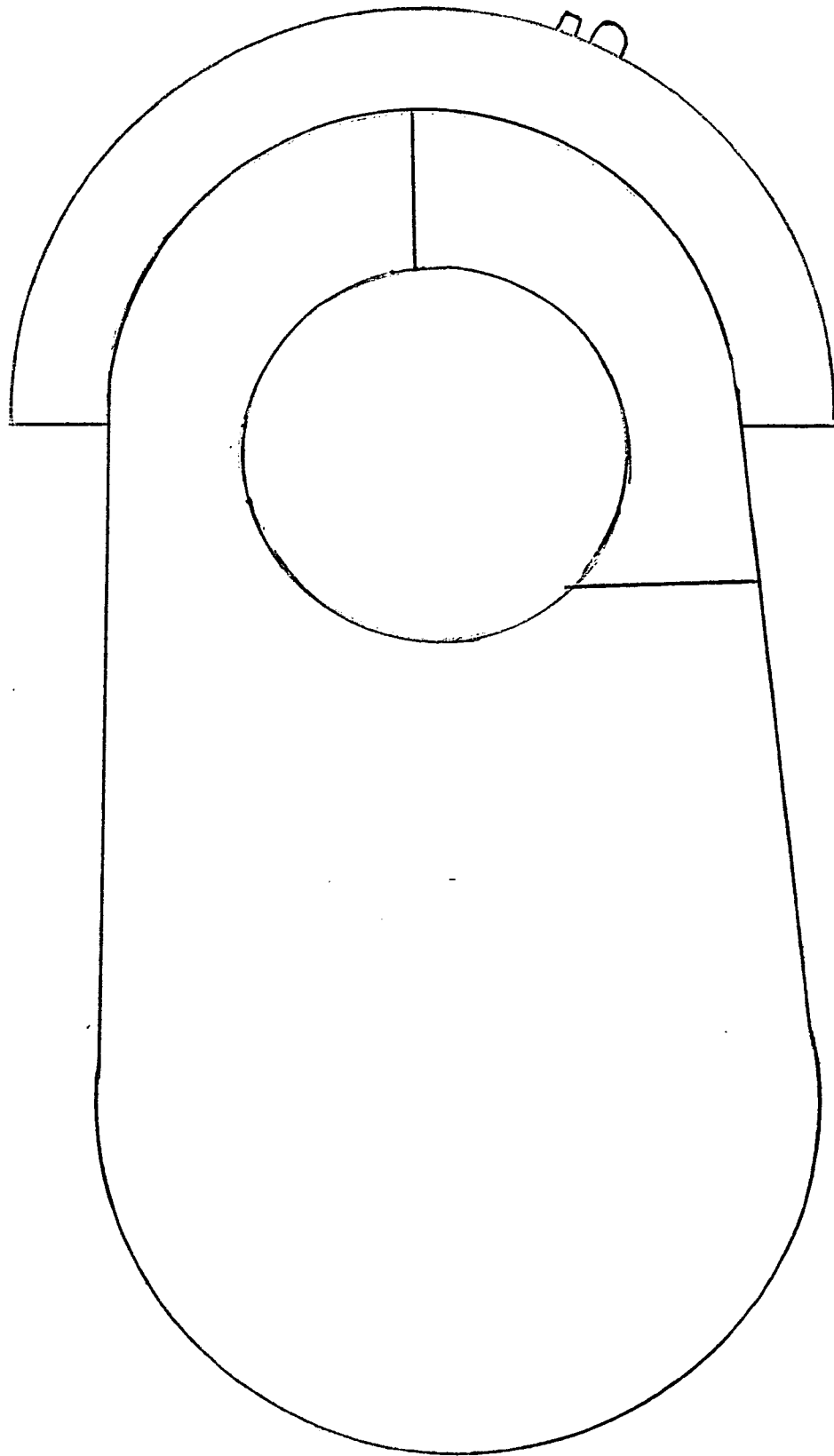

a

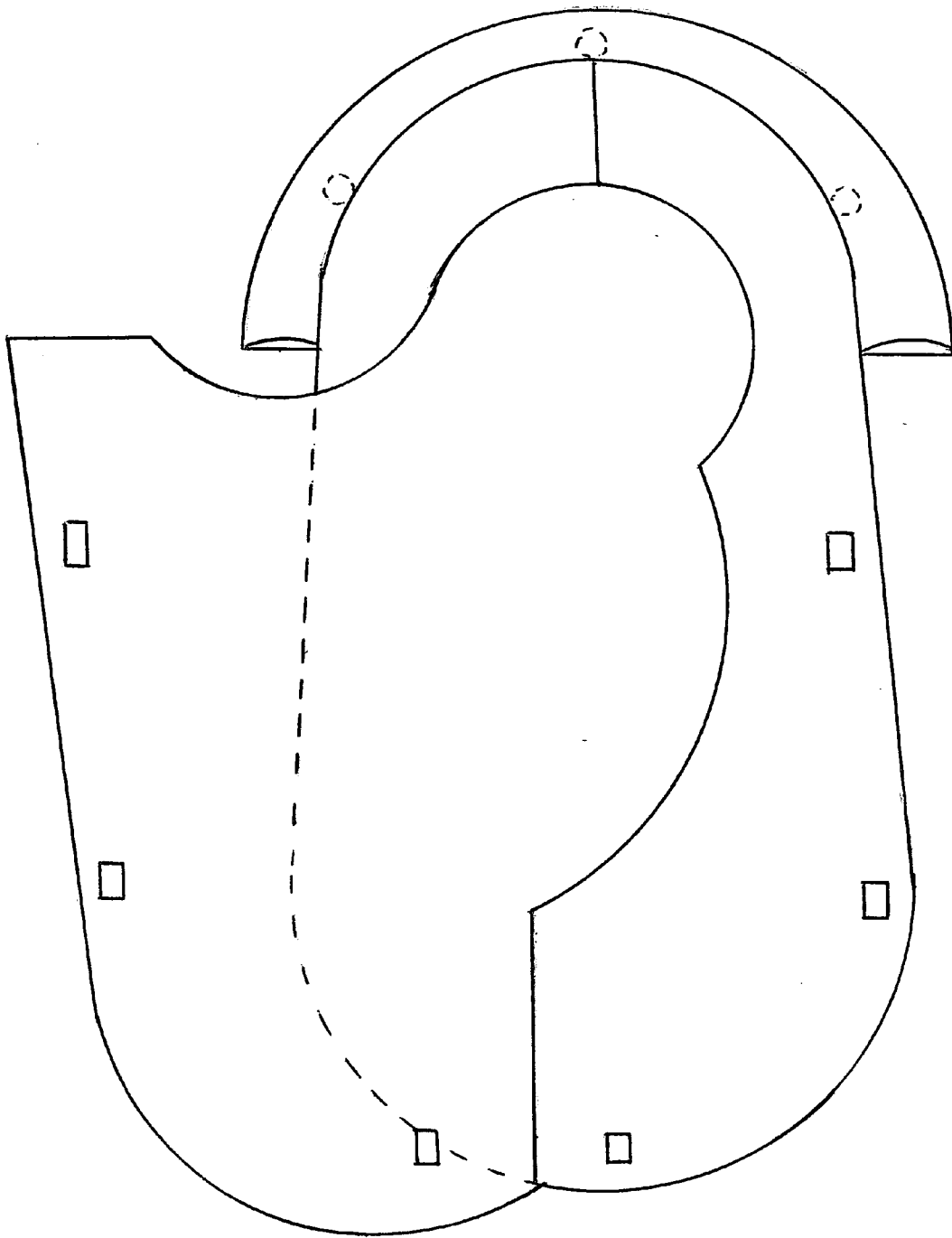

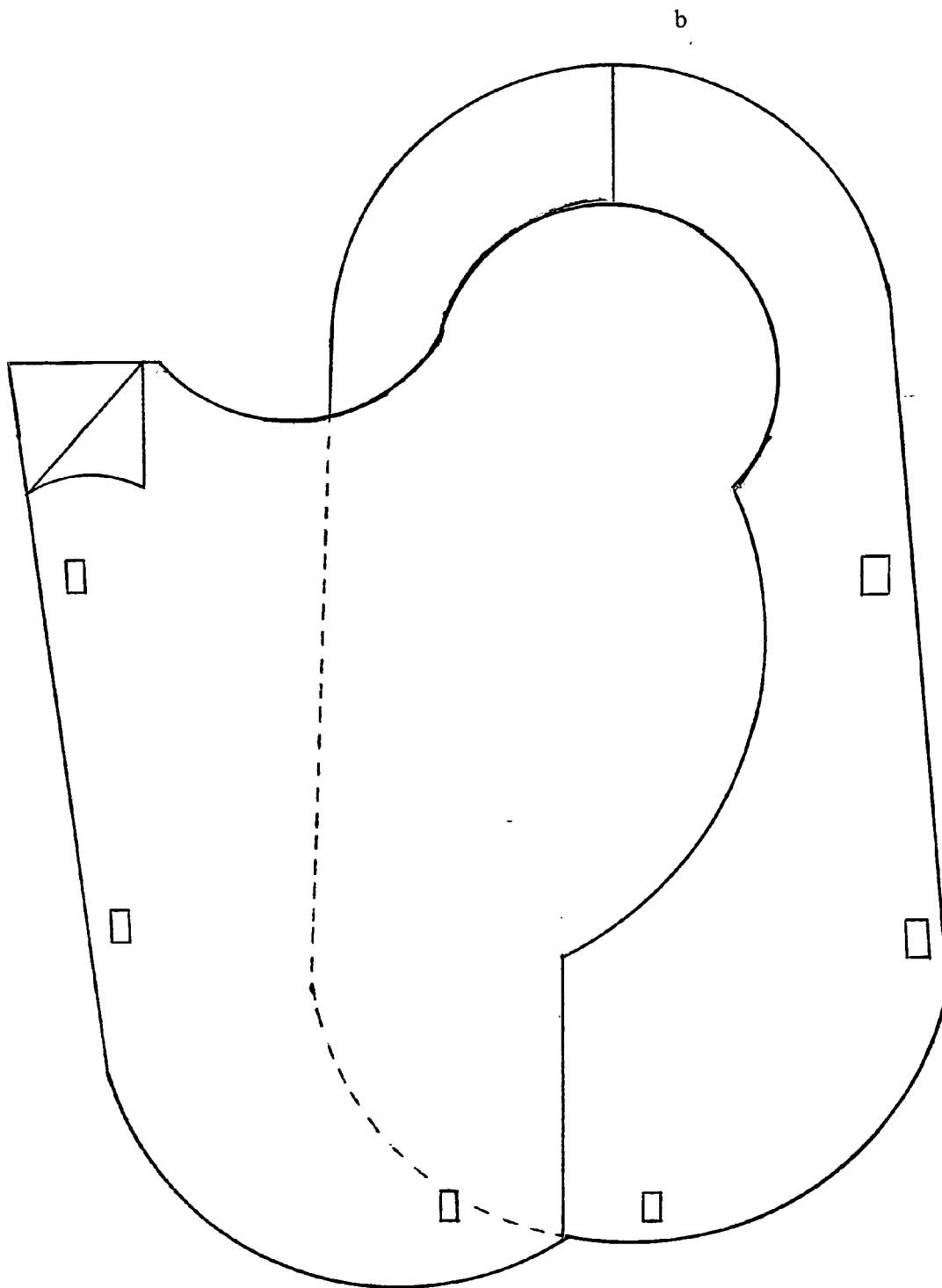

c

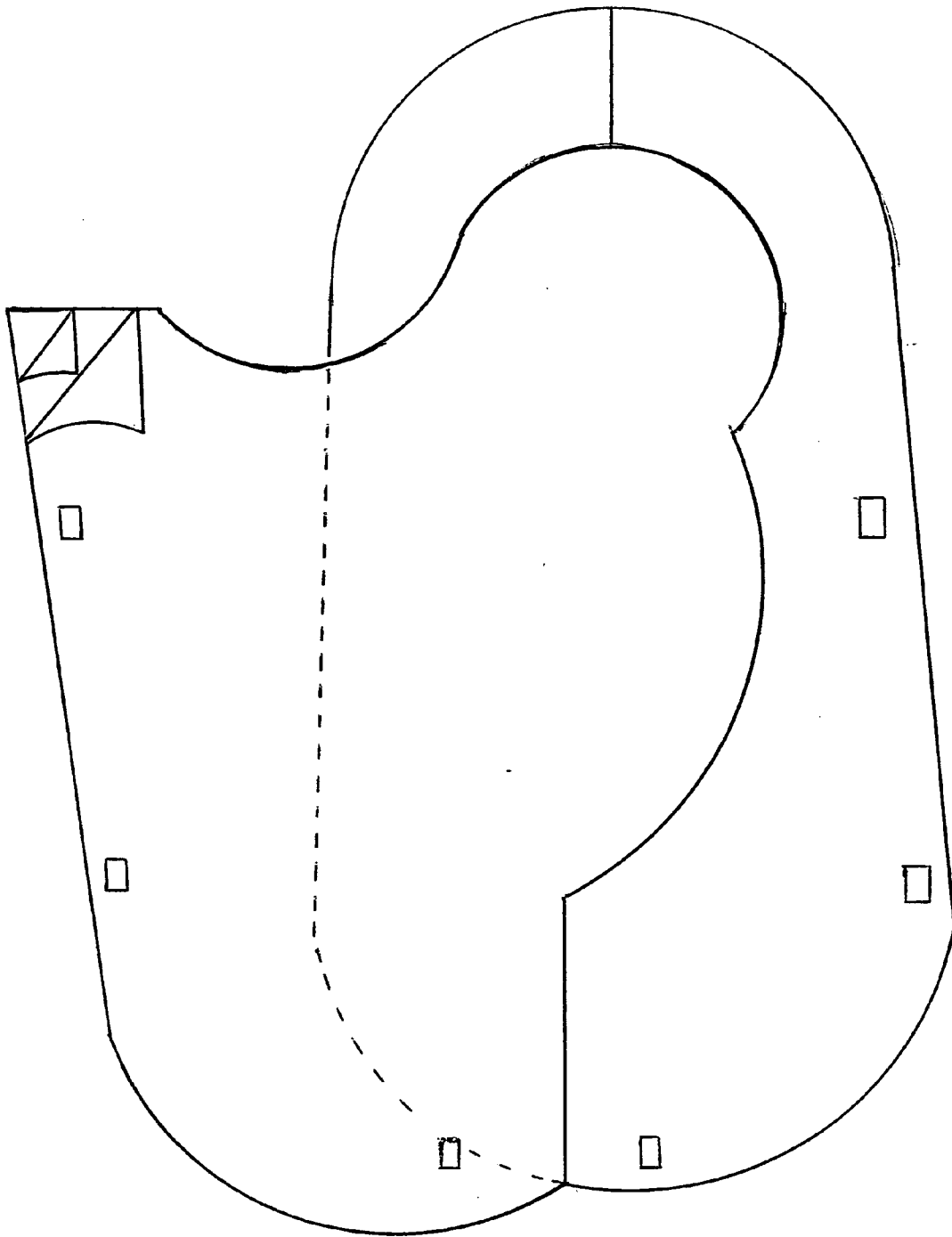

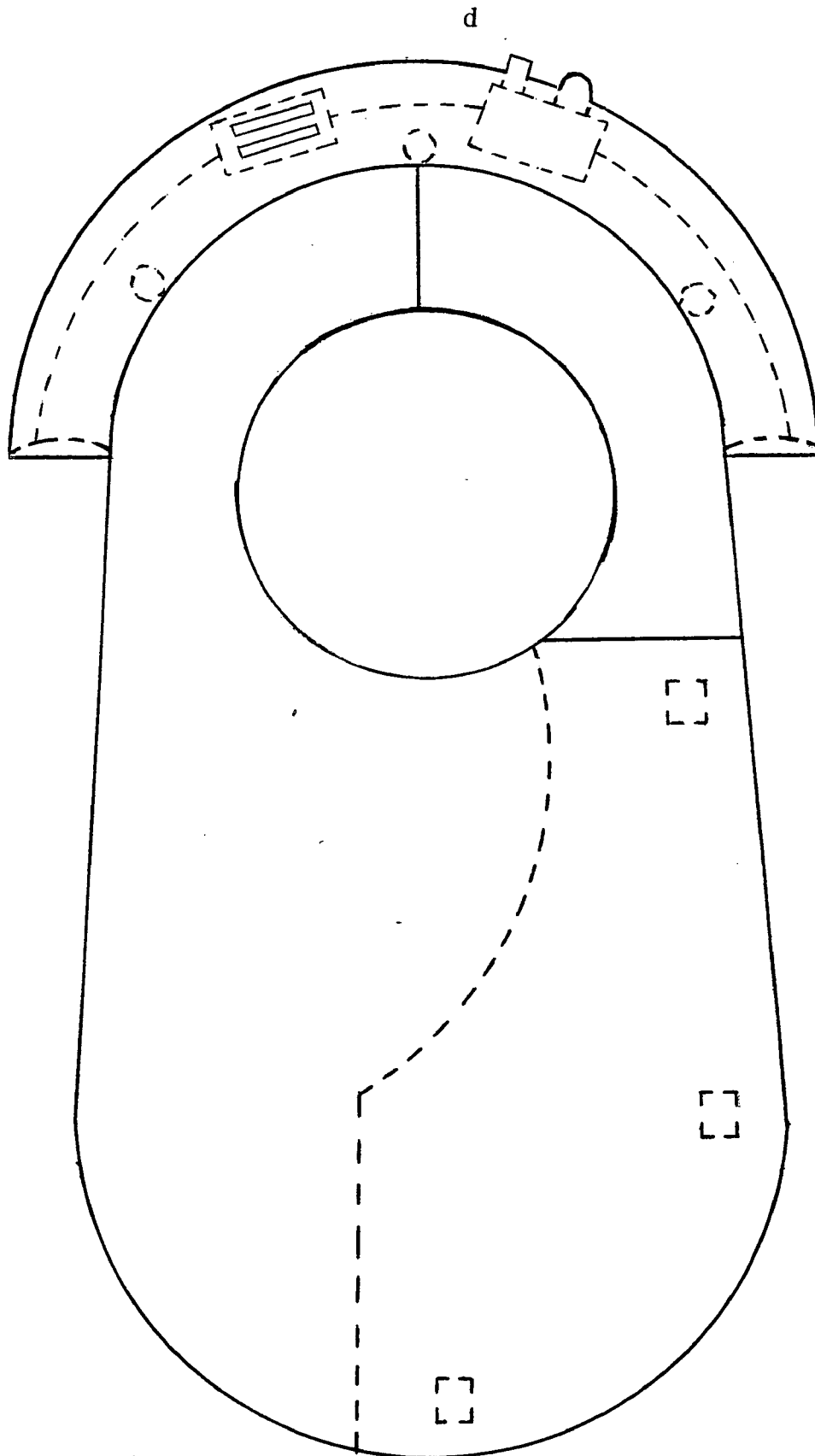

e

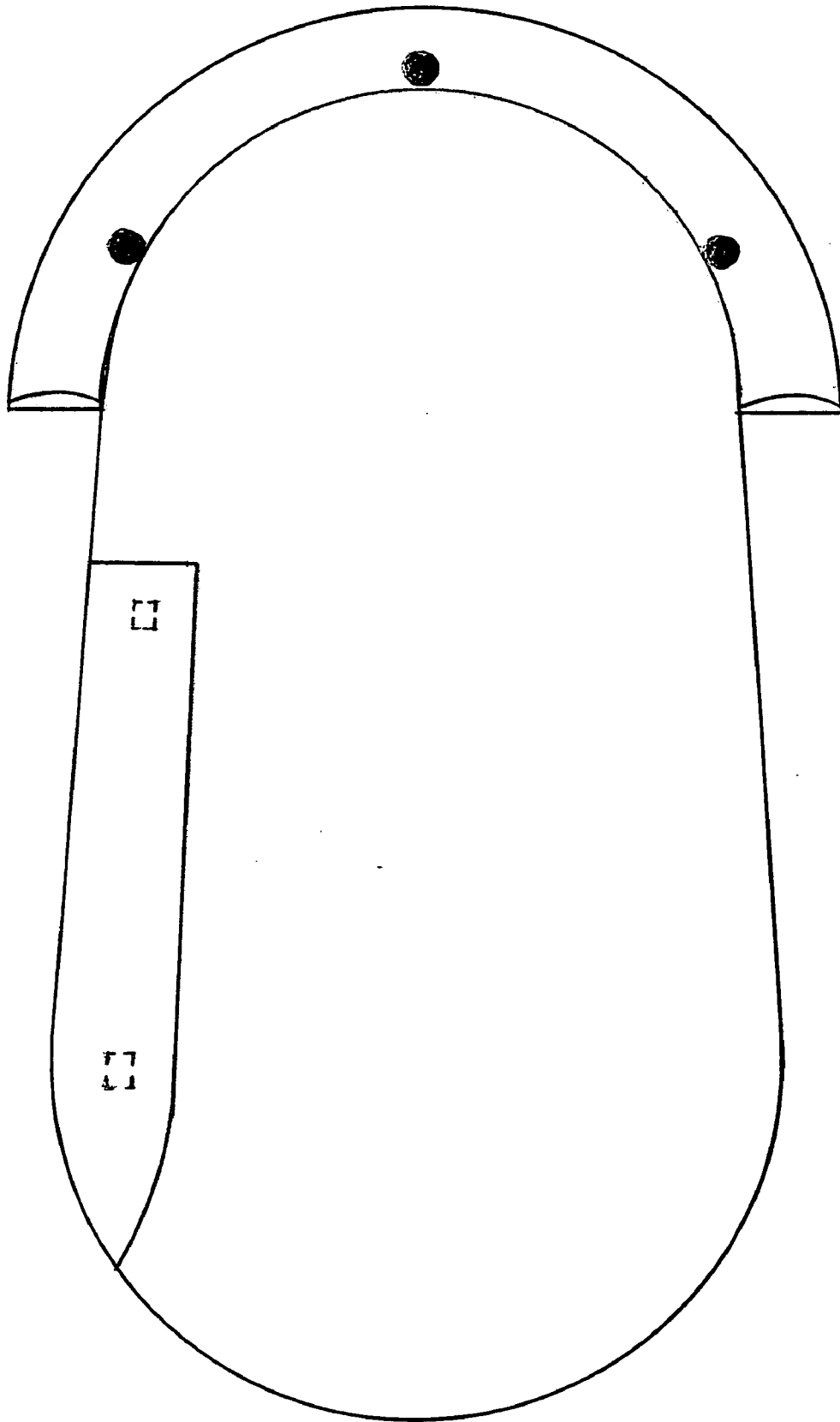

f

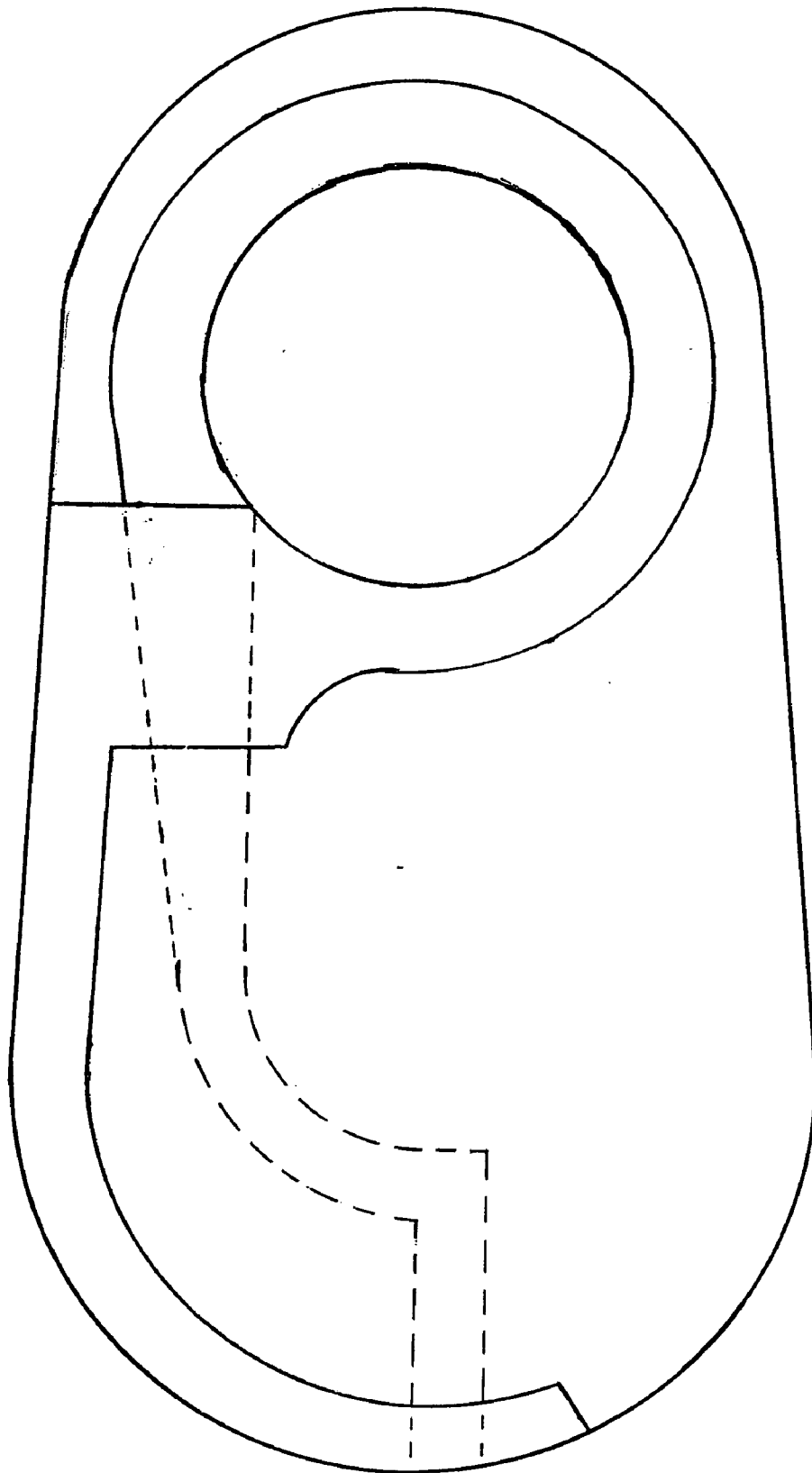



B

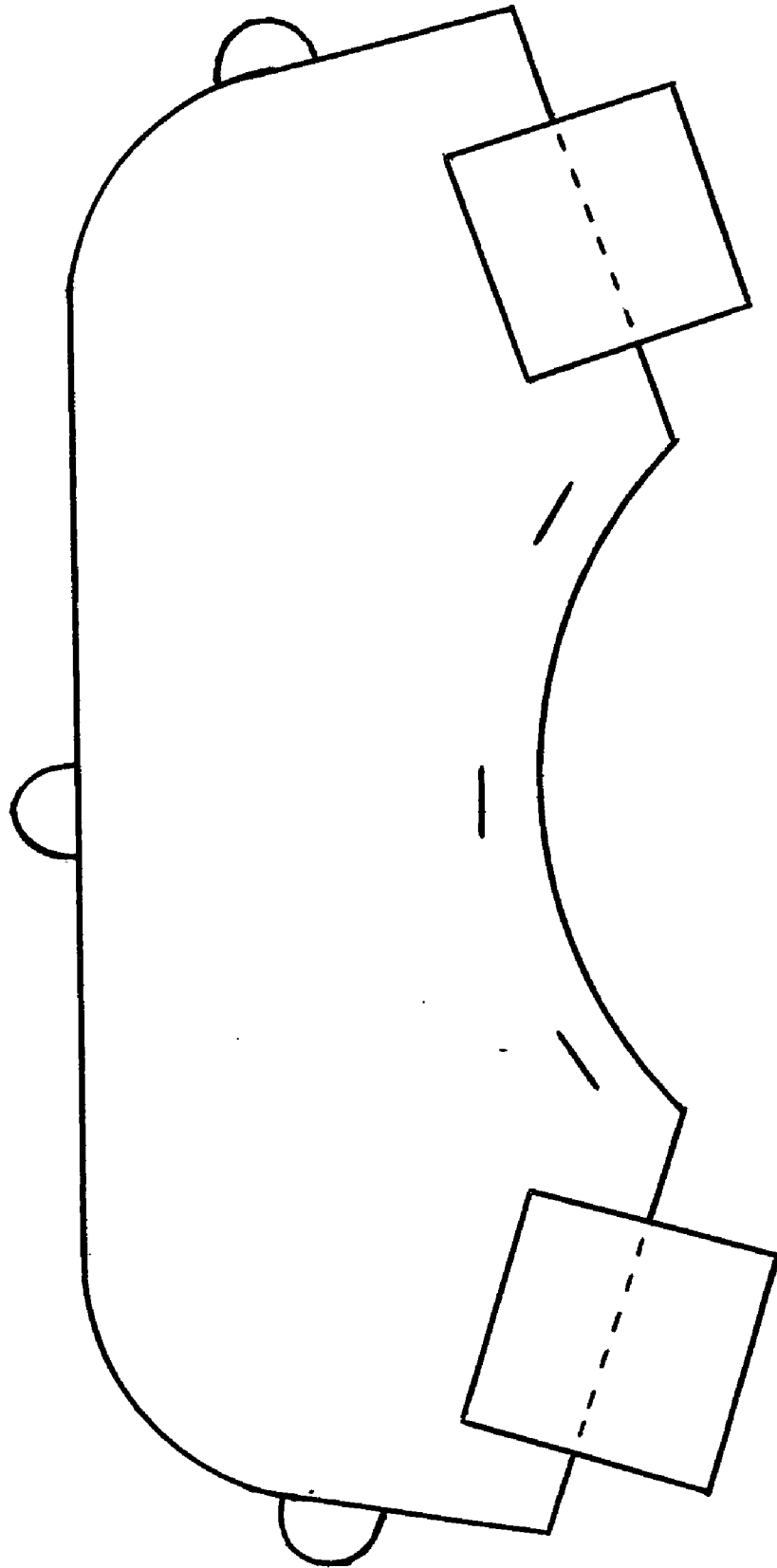

88

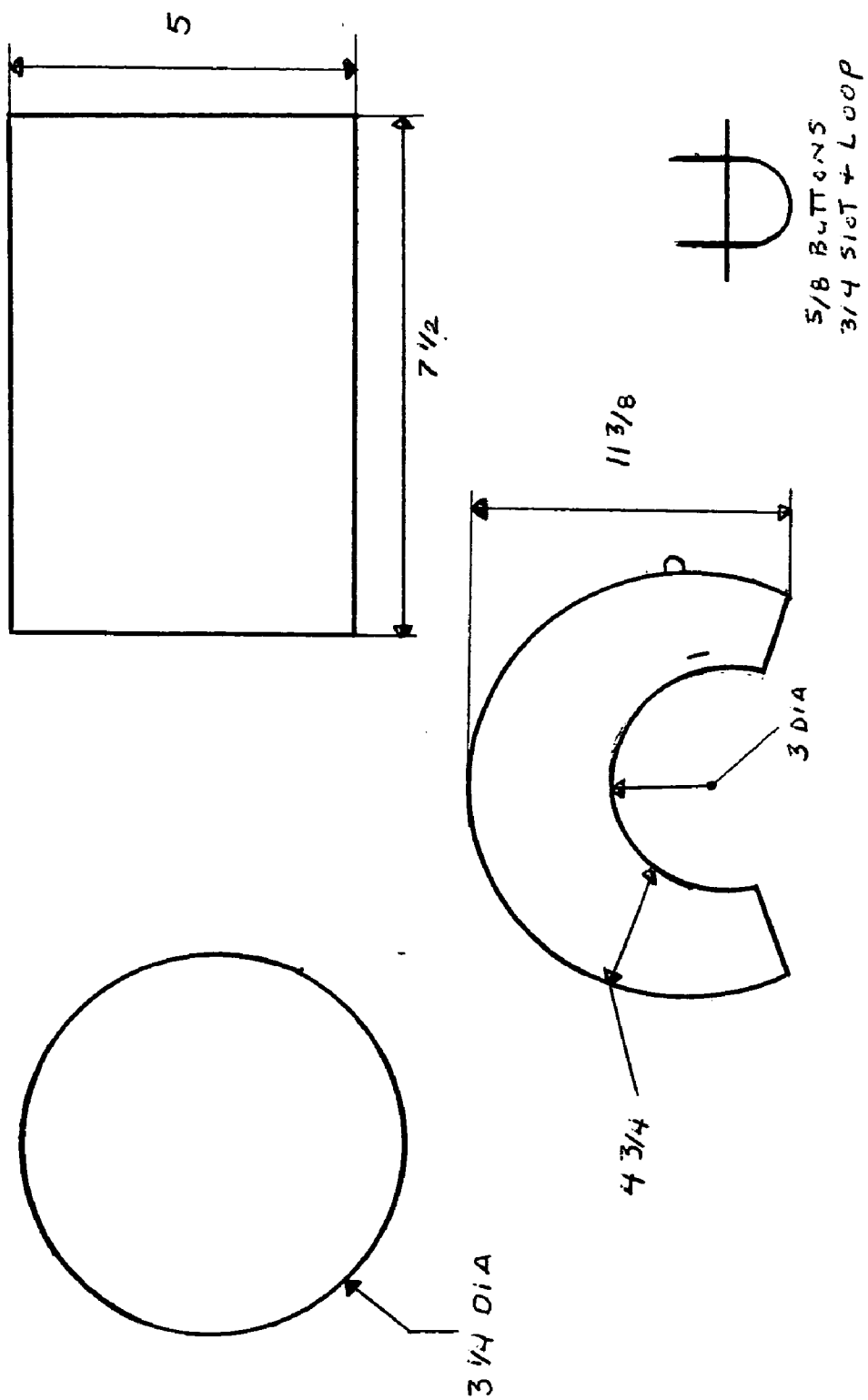

h

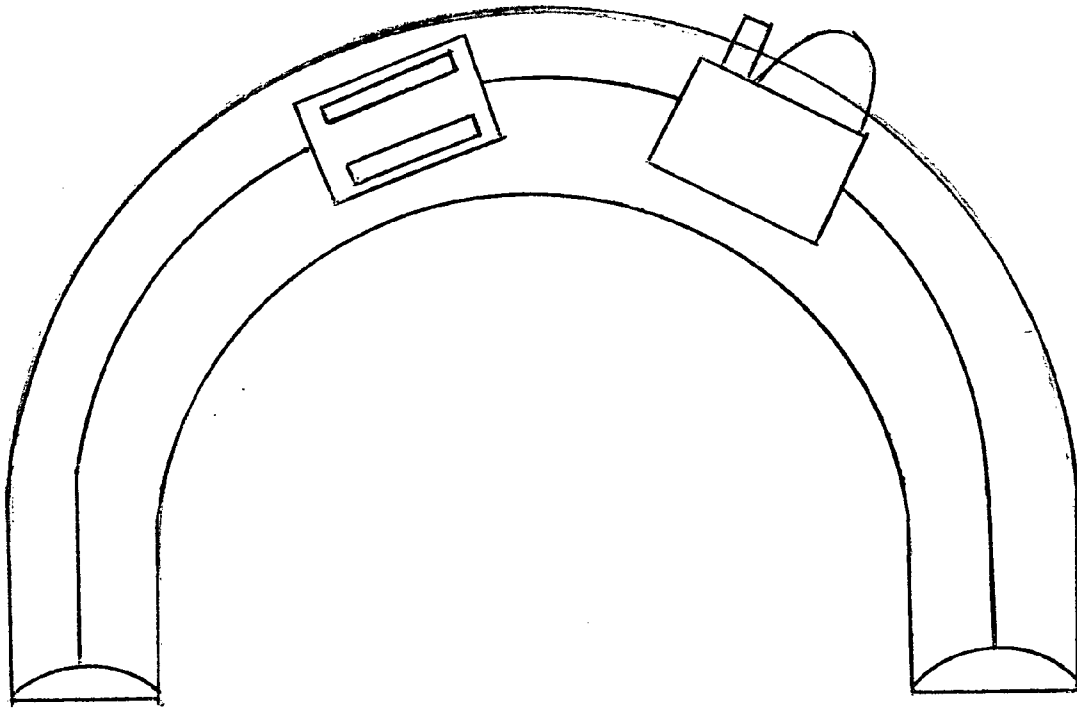

i

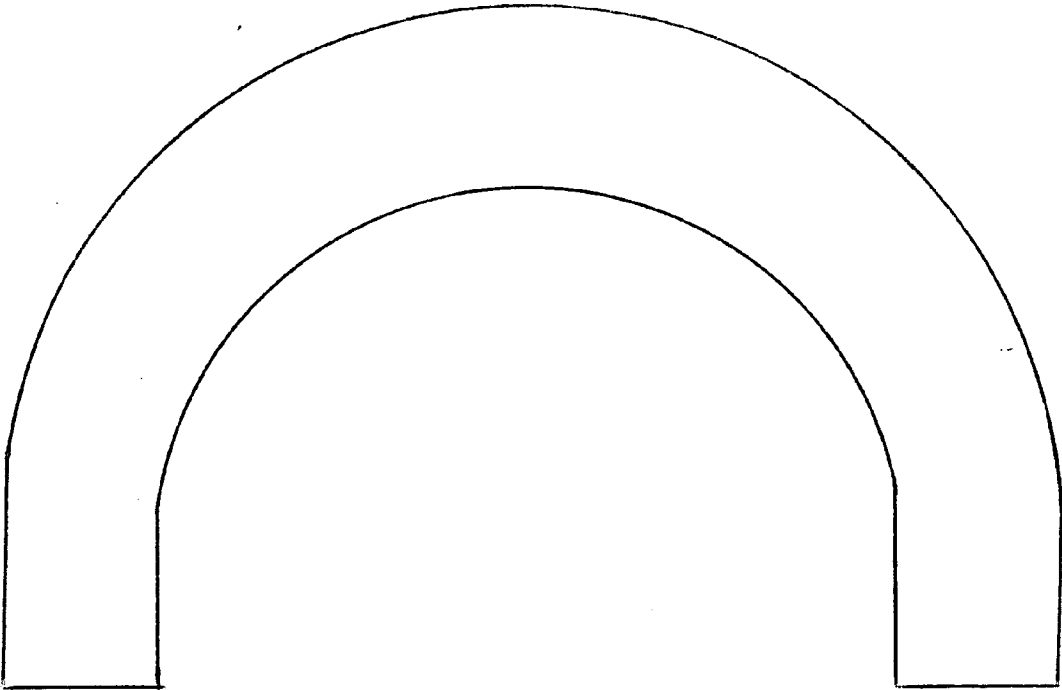

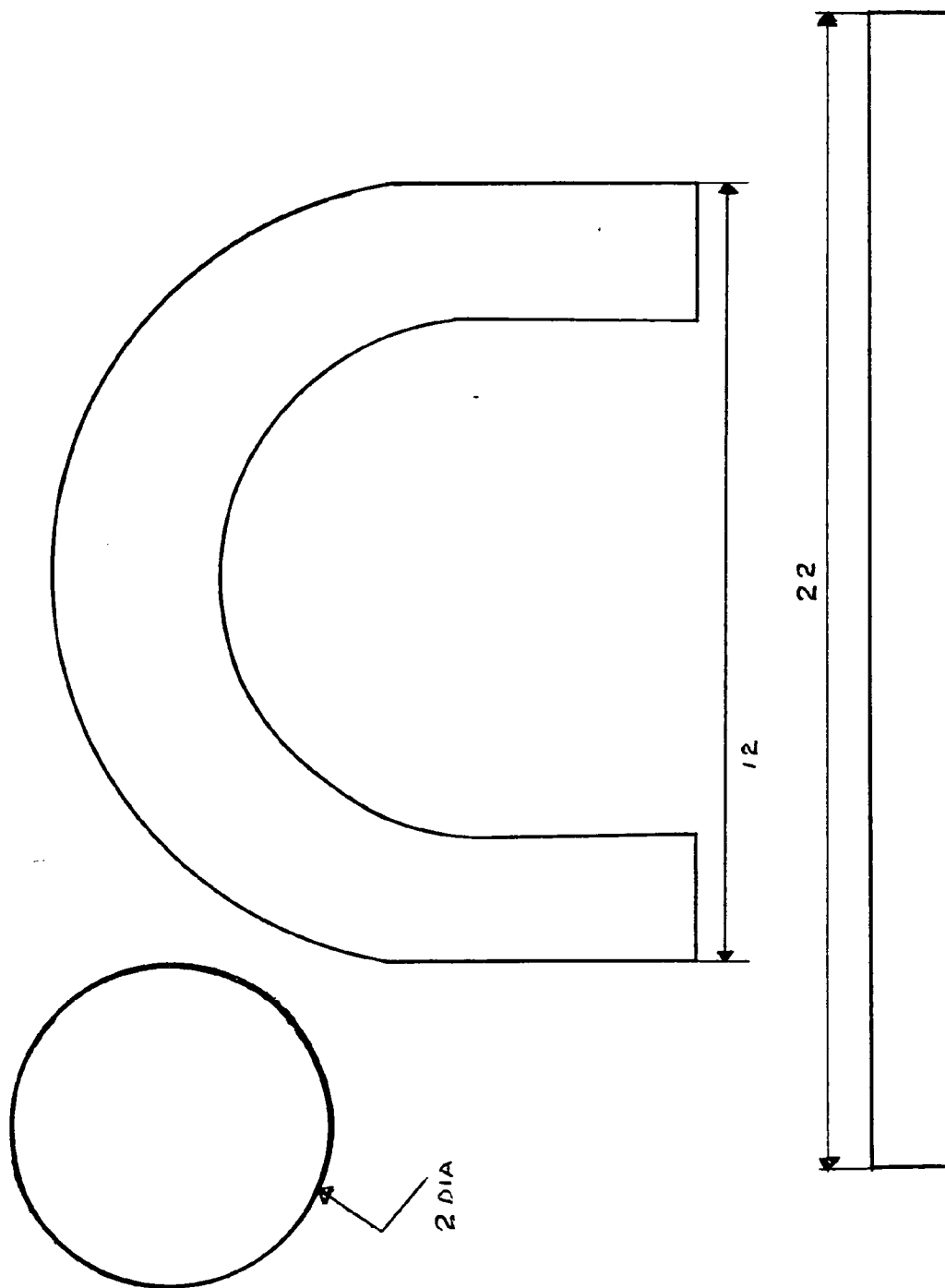

C

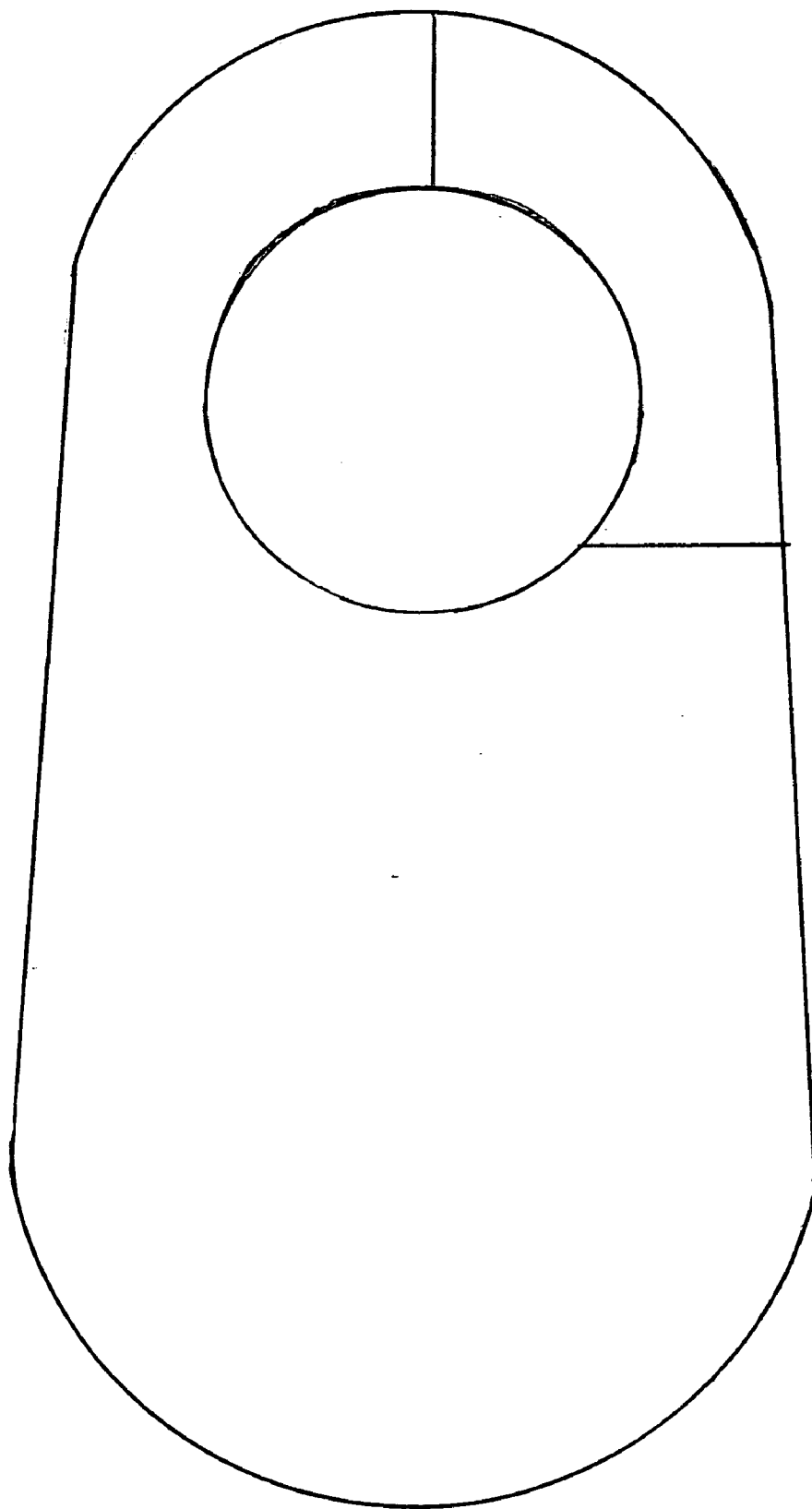

aa

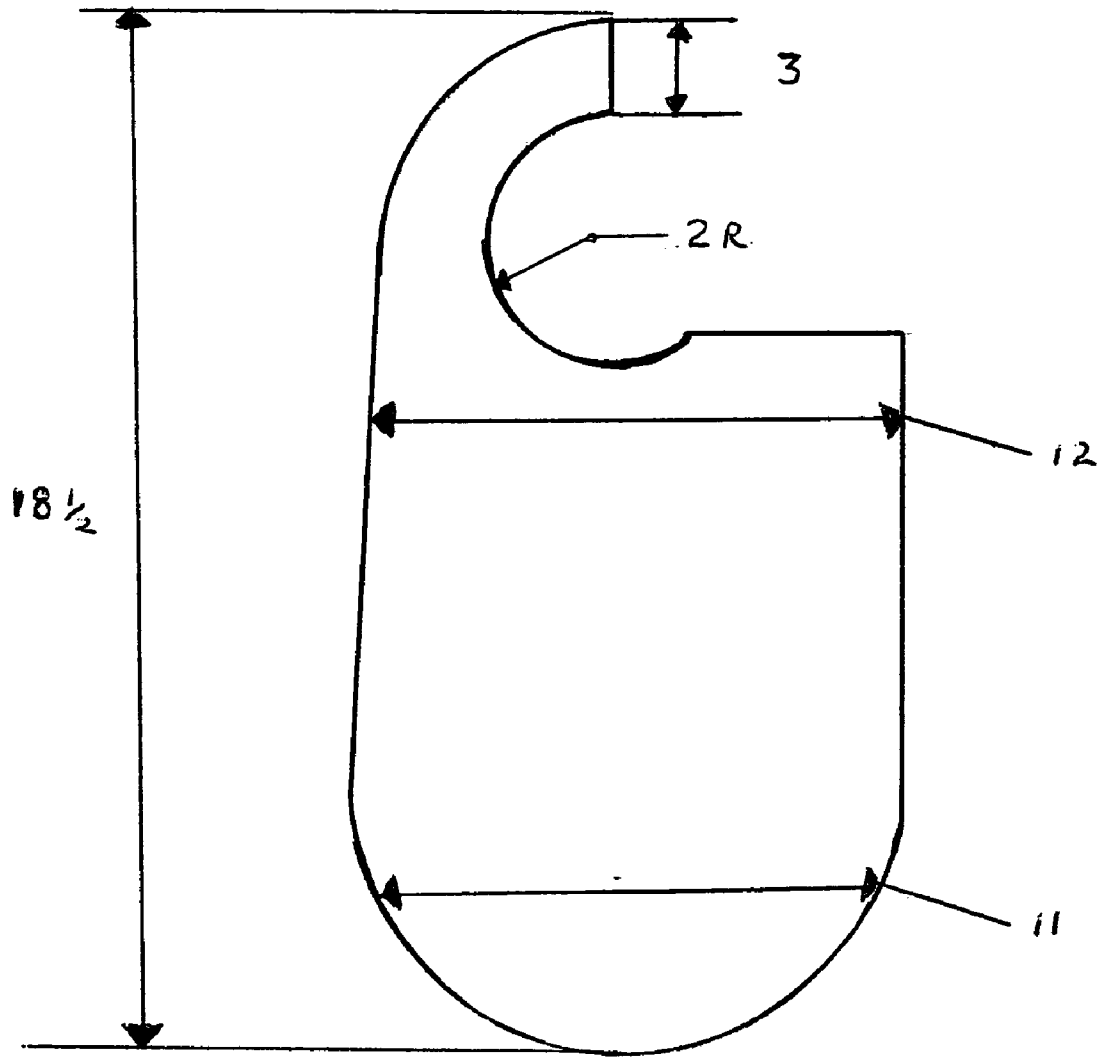

bb

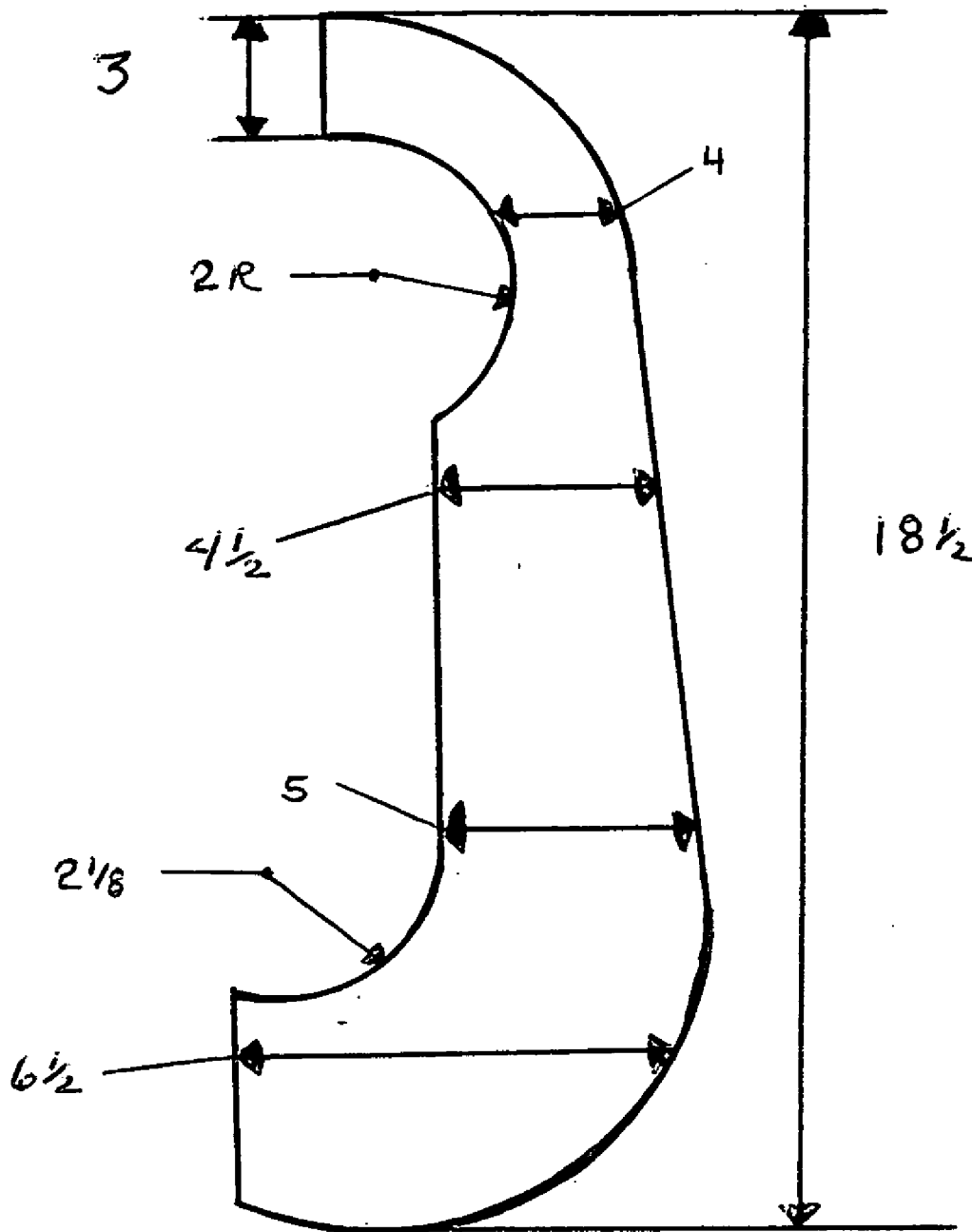



cc

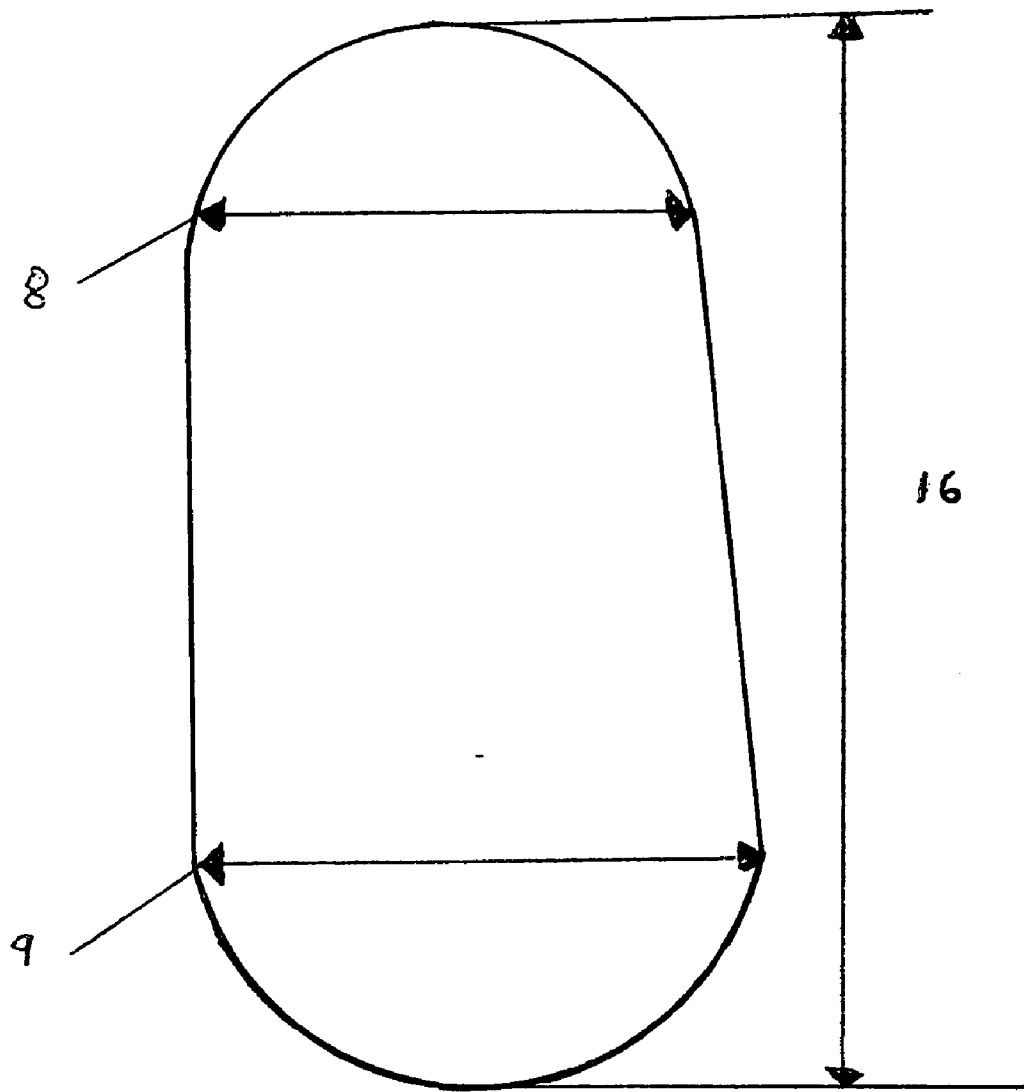

dd

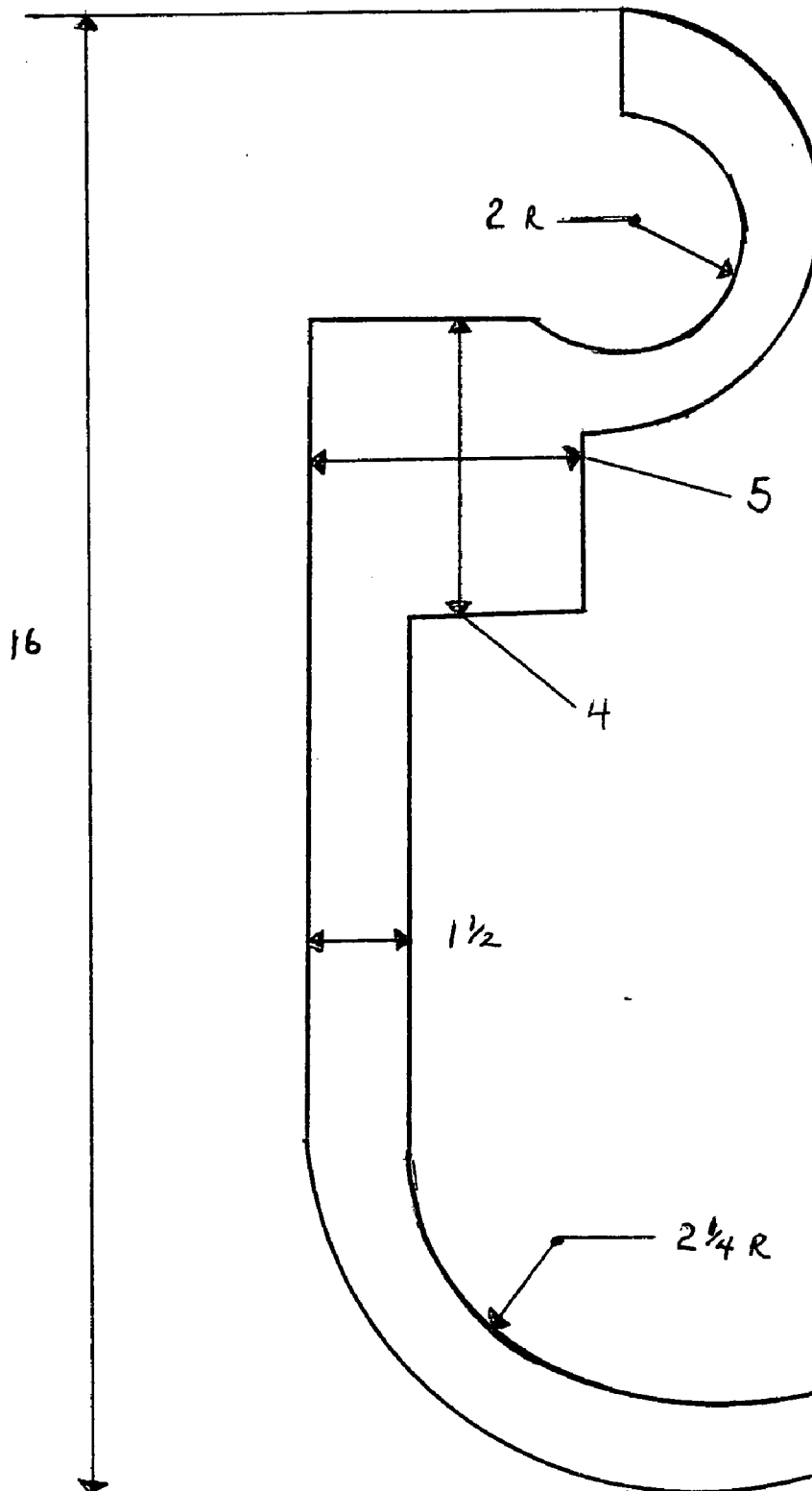

ee

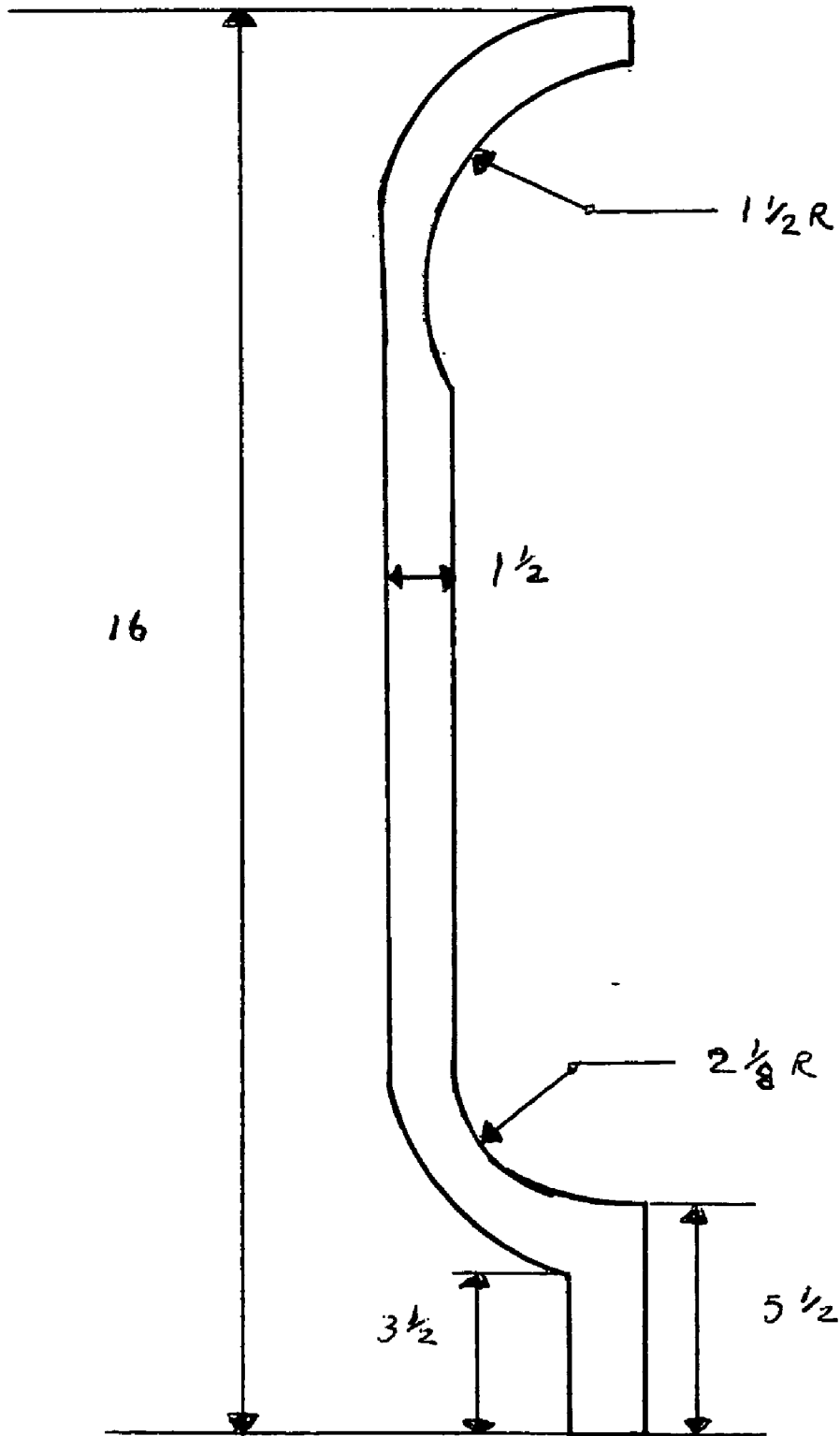

D

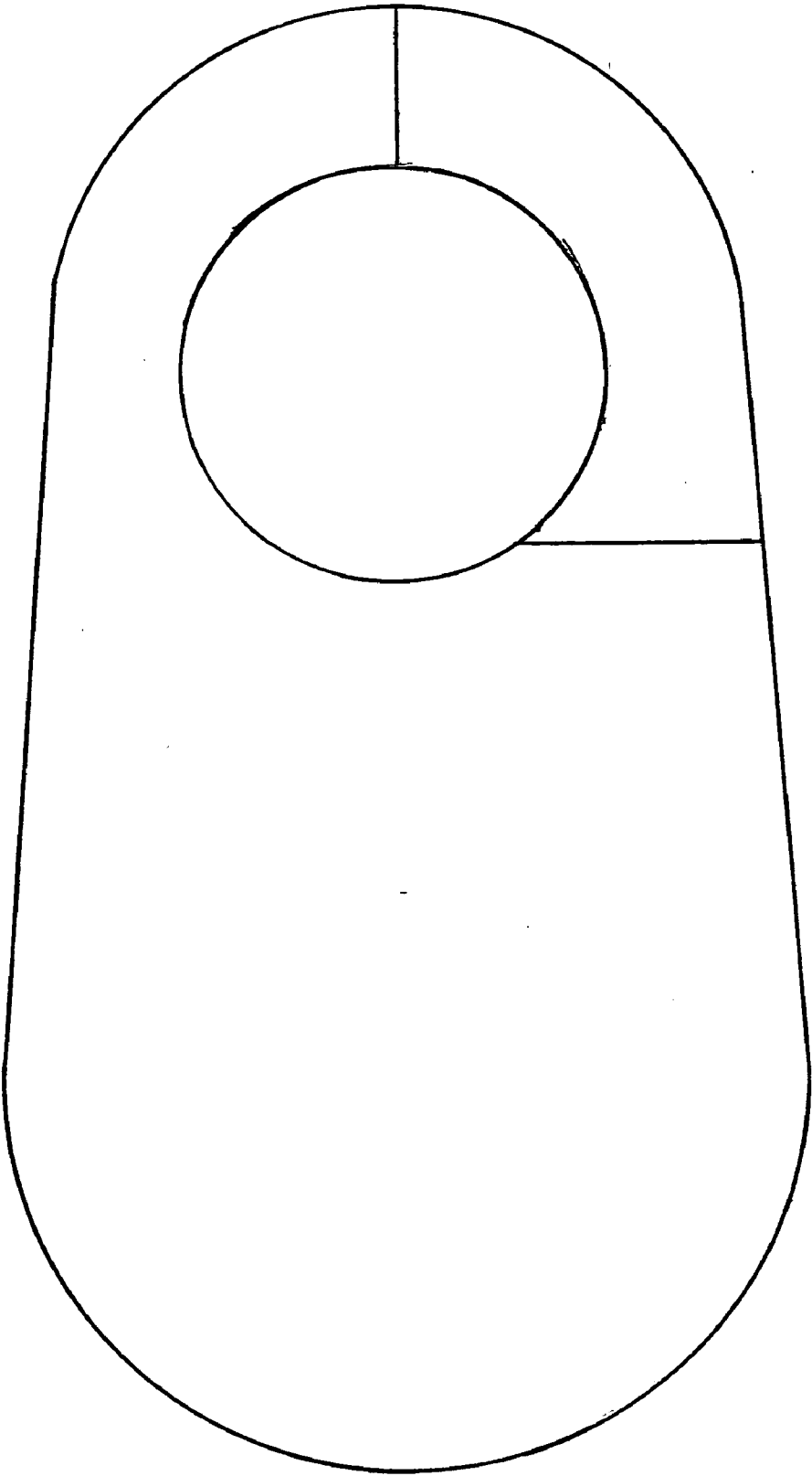

ff

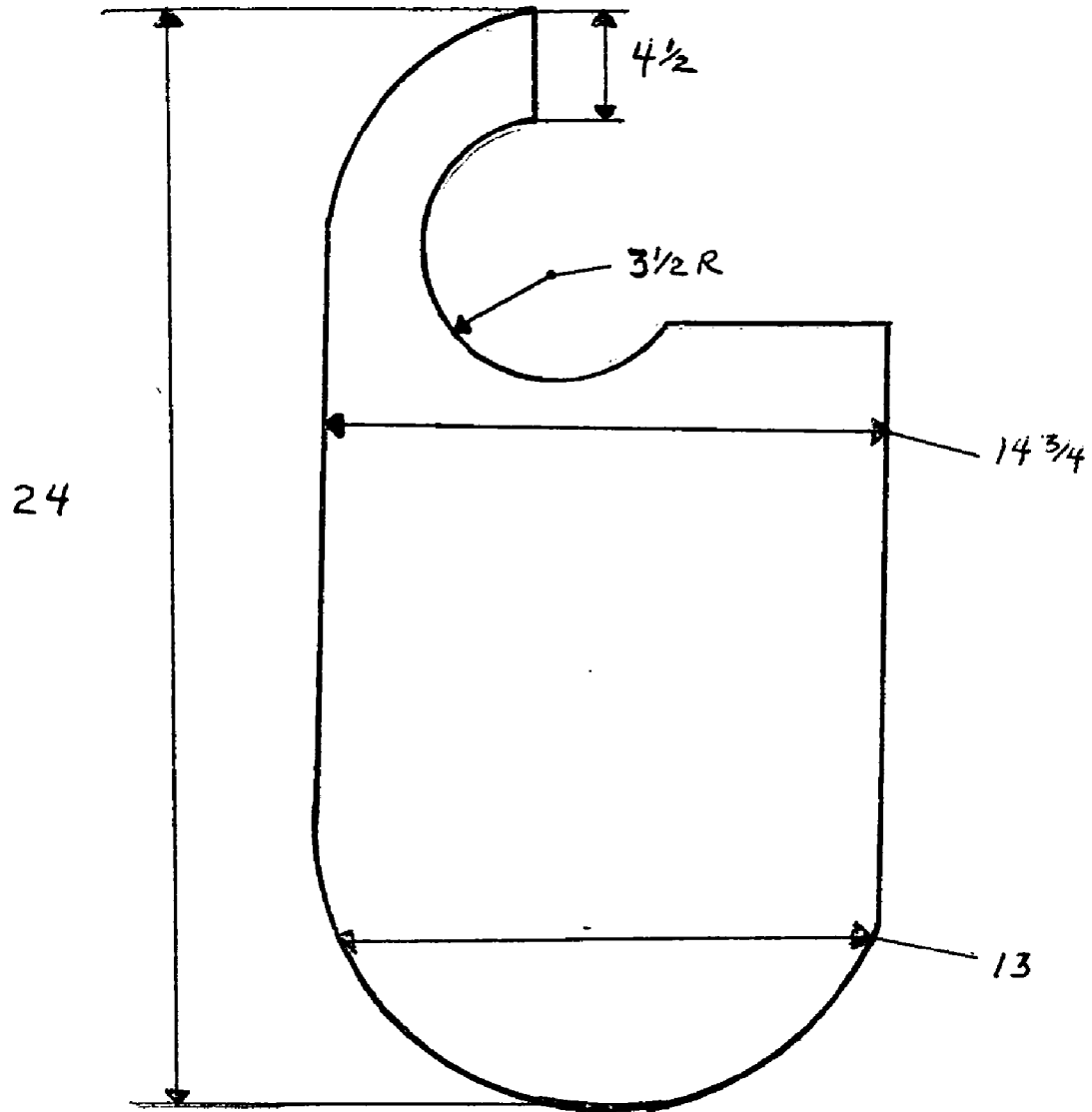

gg

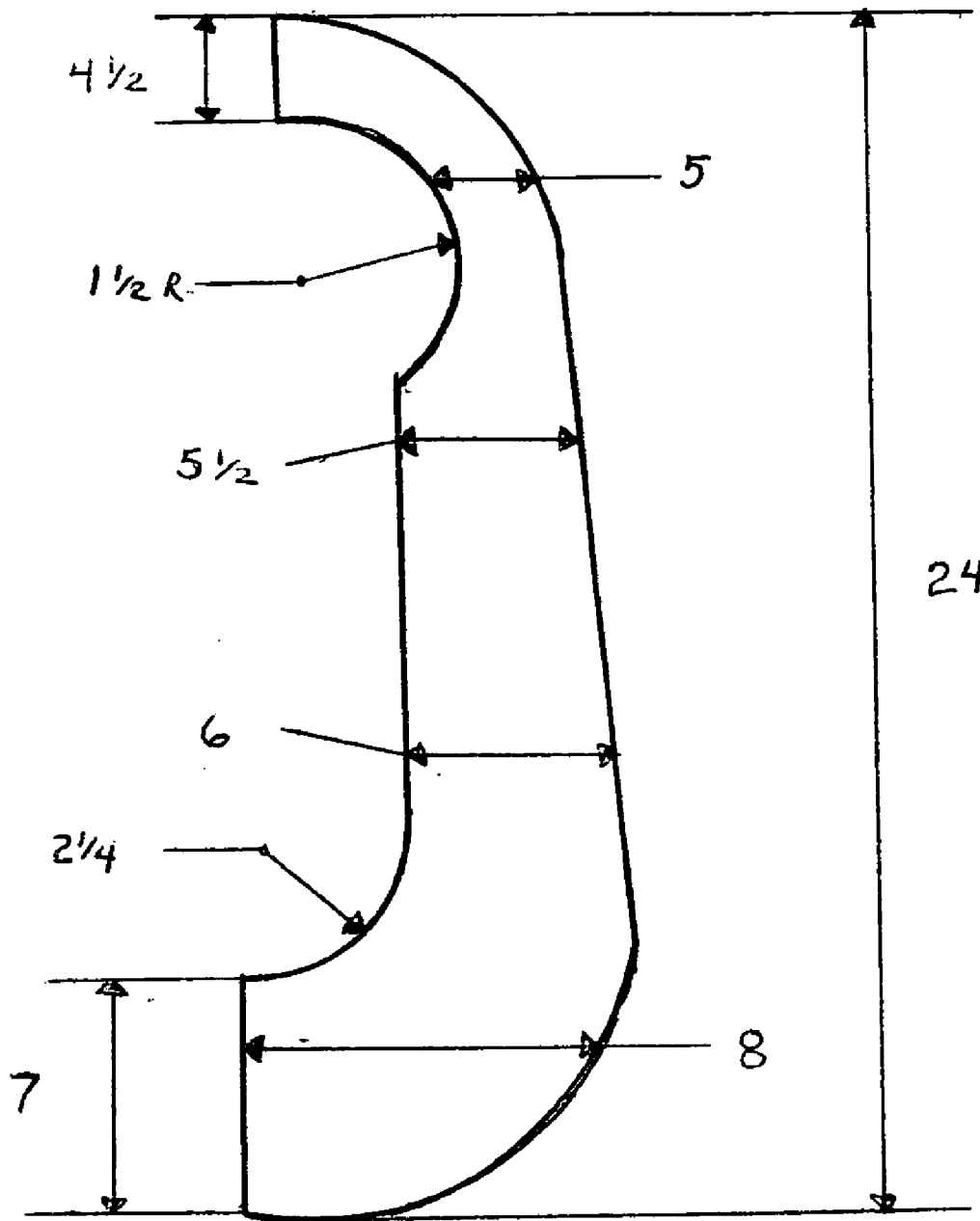

hh

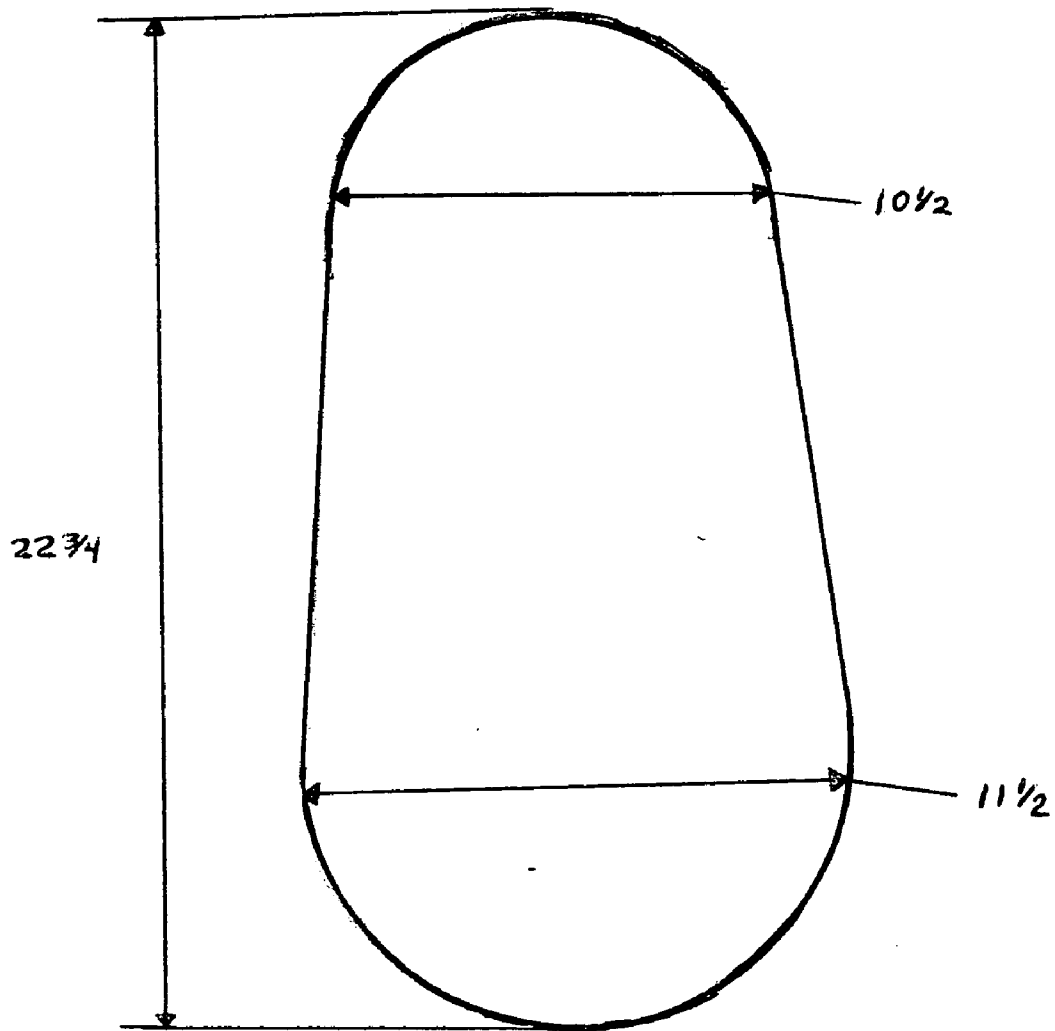

ii

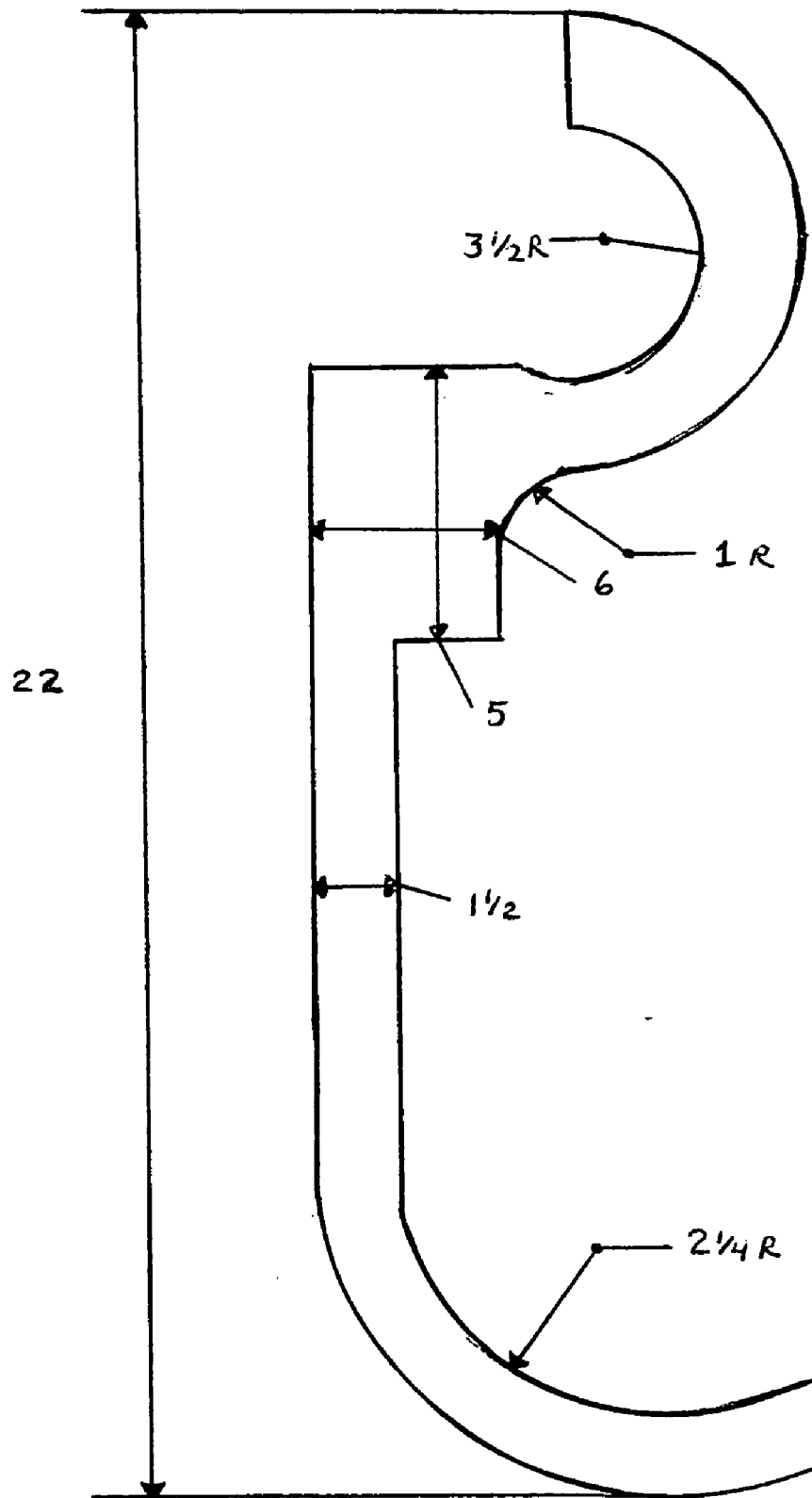



jj

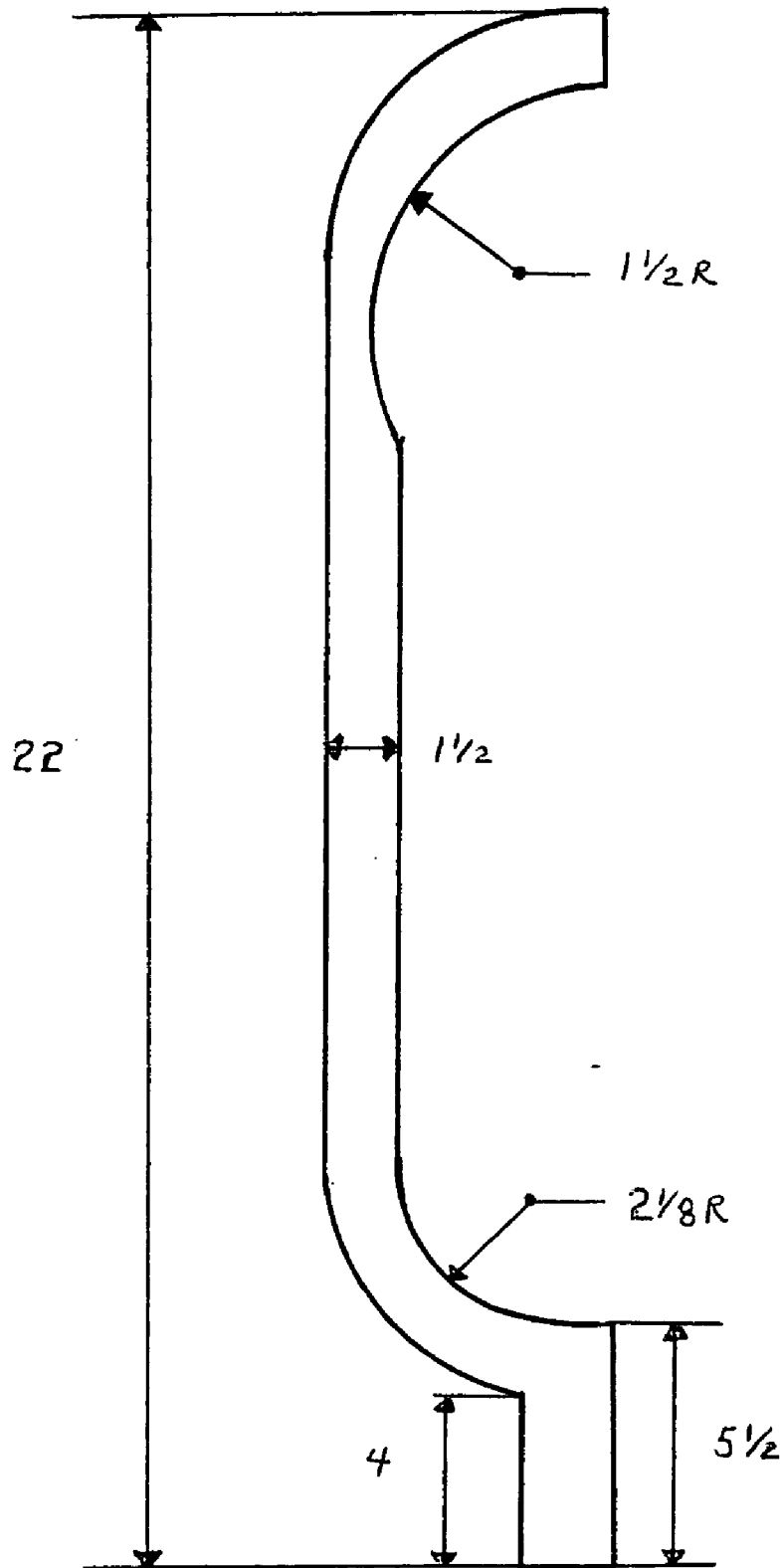

E

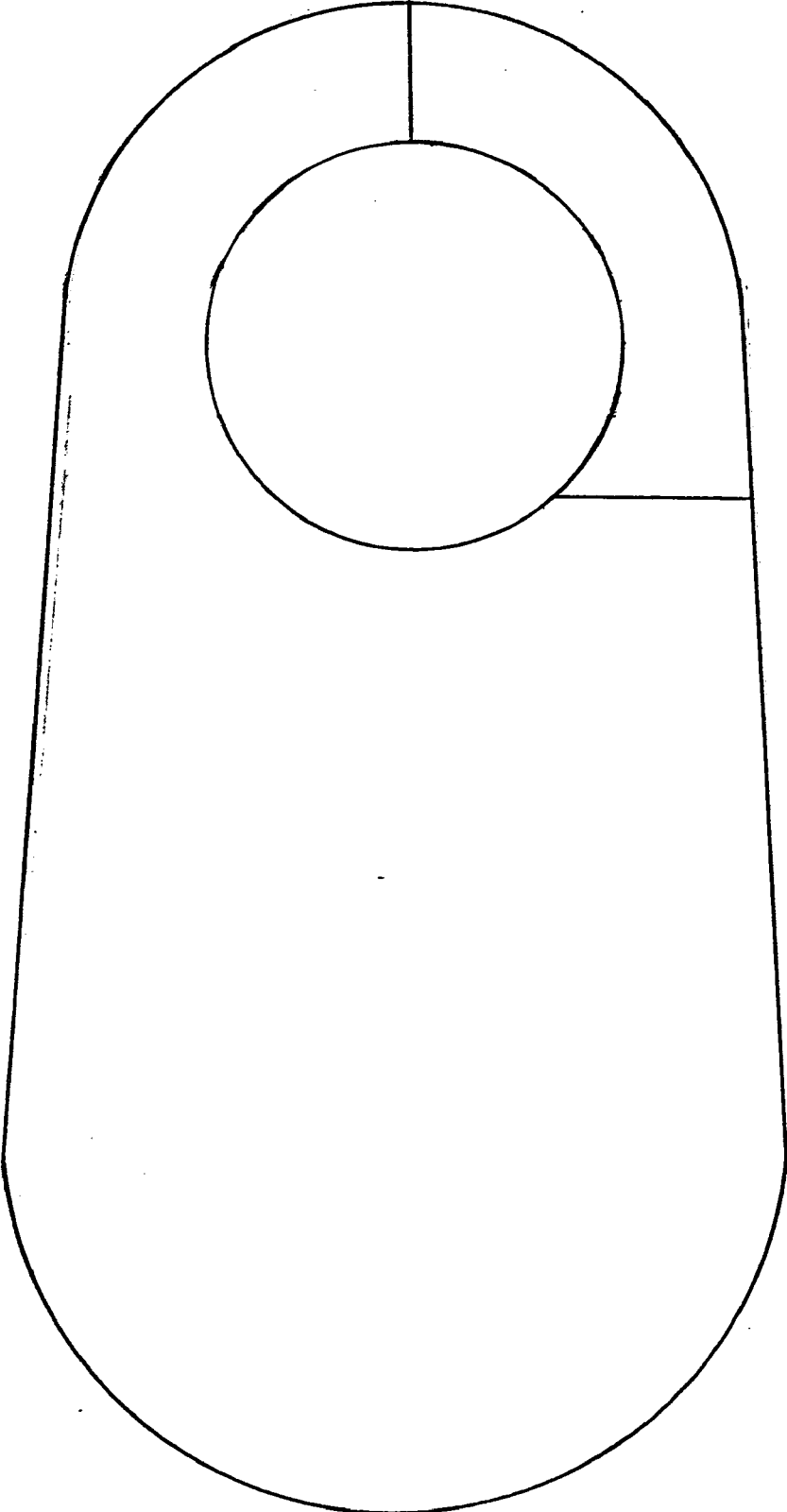

kk

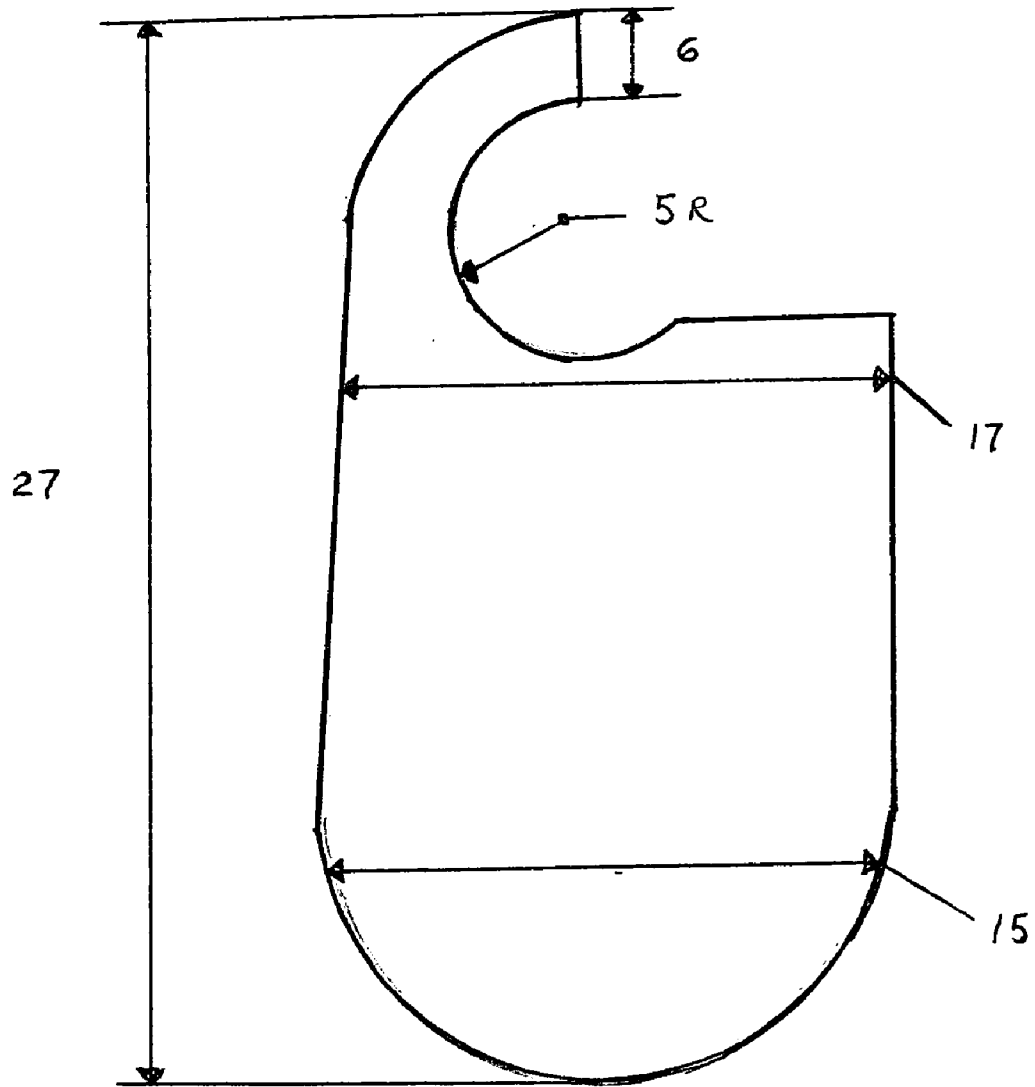

11

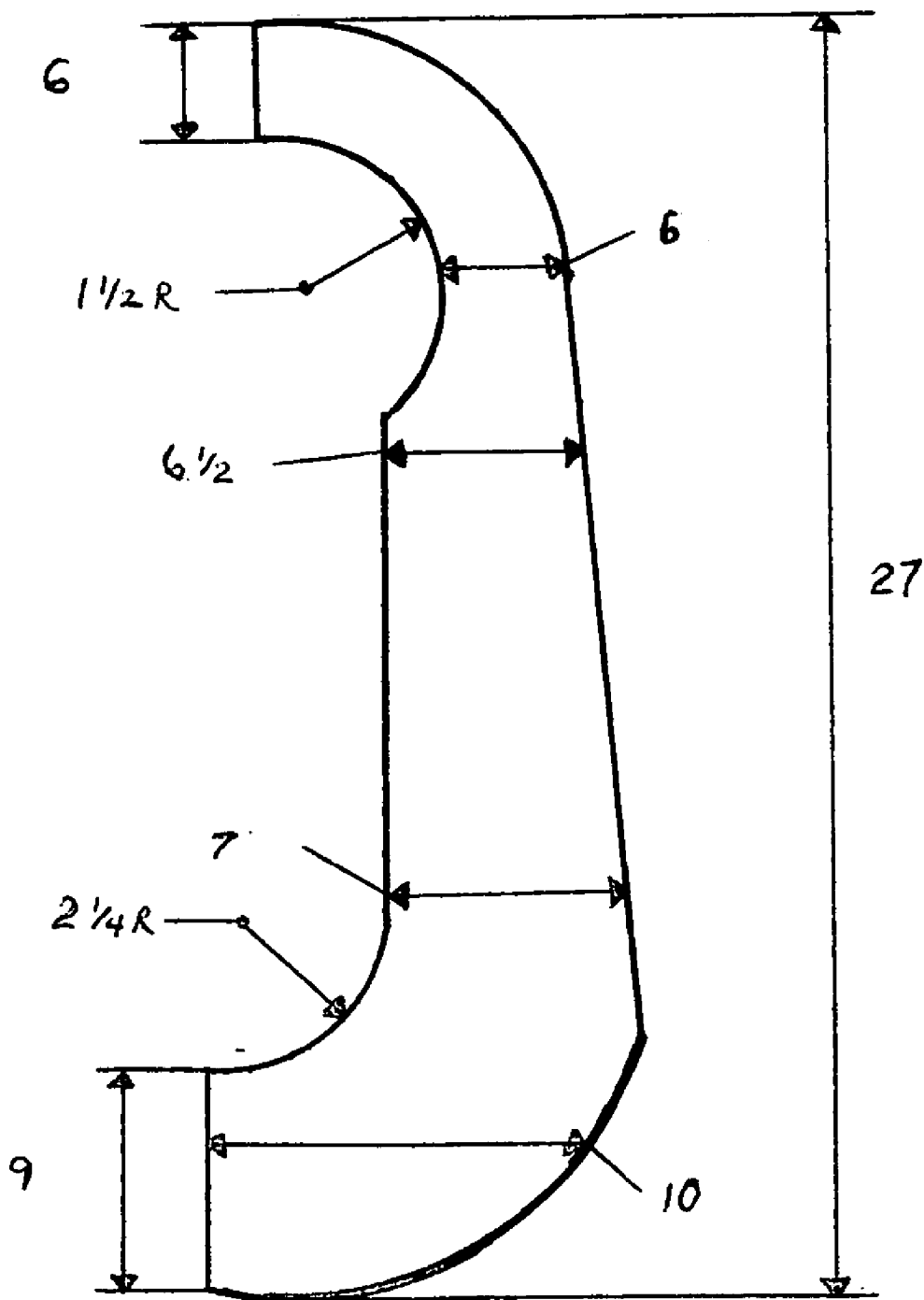

mm

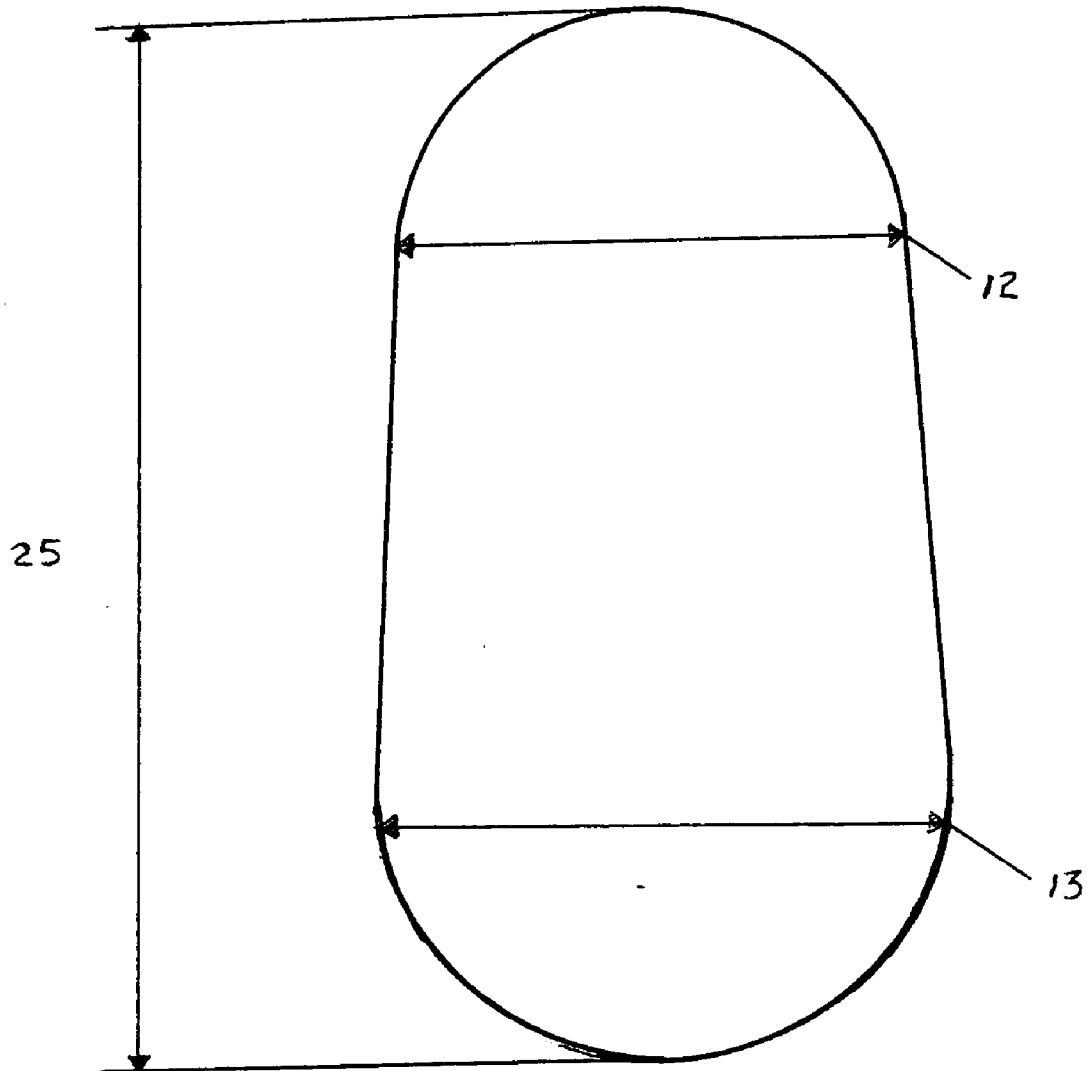

nn

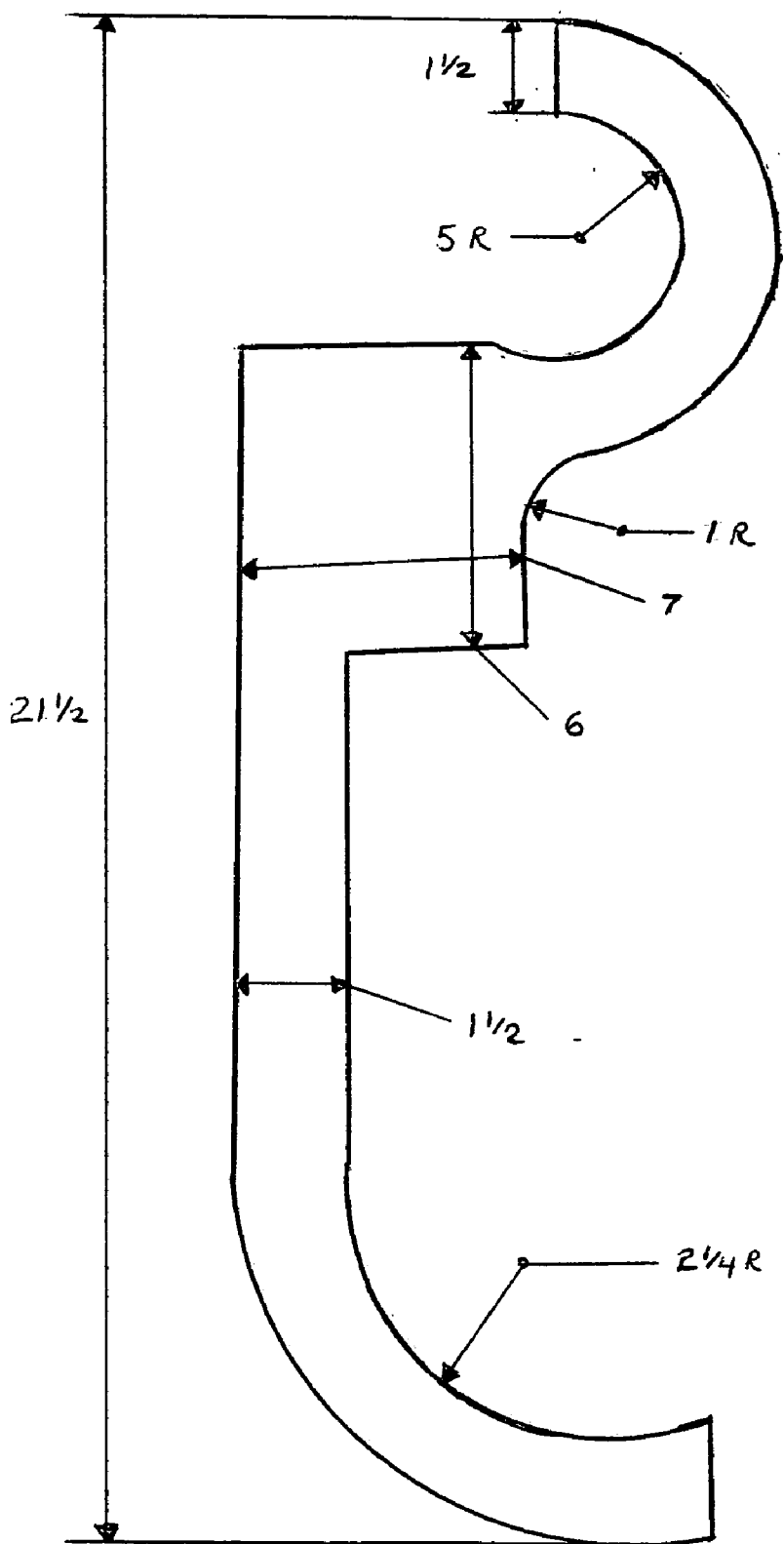

00

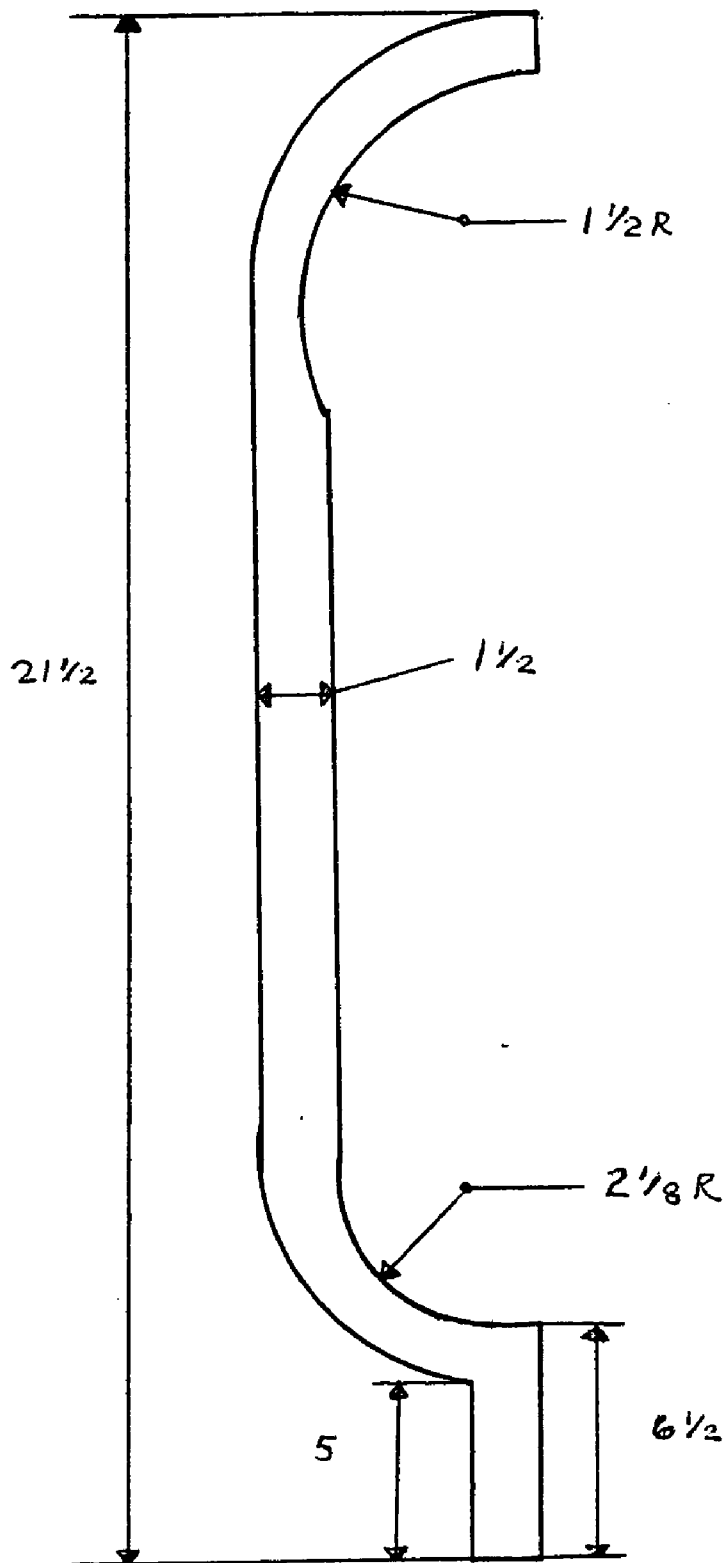

**HUG-ME-TIGHT**

[0001] Oval shaped infant apparel opening from the side by an overlapping flap. Velcro secures the flap over the opposite side. The infant is completely contained except for the face. The hole size varies per size of garment, small—3½ inches, medium—5 inches and large—6½ inches.

[0002] 5 pieces are needed to construct the HUG-ME-TIGHT. They are 1 back, 2 front and 2 interfacings. The front pieces may be sewn in reverse to open on either side. The small measurements are; back—8 inches across the ears area, 9 inches across the ankle area and 16 inches long. The front flap side—3 inches down from the top leading to a 2 inch radius proceeding to 12 inches across the shoulder area, 11 inches across the ankle area, total length 18½ inches. The opposite front side—3 inches down from the top leading to a 1½ inch radius proceeding to 4½ inches across the shoulder area, 5 inches across the hip area proceeding into a 2⅞ inch radius stopping at ⅓ the circle. This is joined to a measurement 6½ inches from the bottom, total length is 18½ inches. Front flap side interfacing—1½ inches down from the top, proceeding into a radius 2 inches, leading to a 5 inch by 4 inch box connected to a straight vertical piece with a 2¼ radius on the end. The total length is 16 inches. The opposite front side interfacing—1½ inches down from the top leading to a radius of 1½ inches, leading to straight vertical piece proceeding to a 2⅞ radius stopping at ⅓ the circle and intersecting with a 4½ inch piece, from the bottom. Total length is 16 inches for both interfacings.

[0003] Interfacing is sewn to the unsewn edge and folded inside to obtain a finished edge. ALL INTERFACING IS 1½ INCHES THICK

[0004] The medium measurements are; back—10½ inches across the ear area, 11½ inches across the knee area and 22¾ inches long. The front flap side—4½ inches down from the top, leading to a 3½ inch radius proceeding to 14¾ inches across the shoulders area proceeding to 13 inches across the ankles, total length is 24 inches. The opposite front side—4½ inches down from the top leading to a 1½ inch radius proceeding to 5½ inch area by shoulders continuing to 6 inch area by hips proceeding to a 4¼ inch radius stopping ⅓ circle intersecting with a 7 inch piece, from the bottom. The front flap side interfacing —3 inches down from the top continuing to a 3½ inch radius, connected to a 6 inch by 5 inch box, connected to a straight vertical piece ending in a 2¼ radius. Opposite front side interfacing—3 inches down from the top, leading to a 1½ inch radius connected to a straight vertical piece proceeding to a 2⅞ inch radius stopping at ⅓ the circle intersecting with a 5½ inch piece, from the bottom. Total length is 22 inches for both interfacings.

[0005] The large measurements are; back—12 inches across the ear area, 13 inches across the ankle area and 25 inches long. The front flap side—6 inches down from the top, leading to a radius of 5 inches, proceeding to 17 inch across the shoulder area continuing to 15 inches across ankle area, total length is 27 inches. The opposite front side—6 inches down from top, leading to a 1½ inch radius proceeding to 7½ inch area by shoulders proceeding to a 9 inch area across the hip area connected to a 2¼ inch radius intersecting with a 9 inch piece, from the bottom, total length is 27 inches. The front flap interfacing—4½ inches down from the top, leading to a 5 inch radius, connected to a 7 inch by 6

inch box leading to a straight vertical piece, connected to a radius of 2¼ inches, total length is 25½ inches. The opposite front side interfacing—4½ inches down from the top, leading to a radius of 1½ inches connected to a straight vertical piece connected to a radius of 2⅞ inches, intersected to a 6½ inch piece, from the bottom. Total length is 21½ inches for both interfacings.

[0006] The HUG-ME-TIGHT is available in three versions, summer, spring/fall and winter. The summer version is made with one layer of 100% cotton flannel, the spring/fall version is made with two layers; one being 100% cotton flannel and the other fleece, the winter version is made with three layers; one 100% cotton flannel and two layers of fleece.

[0007] The sound device and connections are encased inside a hollow poly foam tube. The components of the sound device consist of; 2 speakers inserted into opposite ends of the tube, both speakers are connected, by wire, to a battery pack and a off/on & timer unit located in the upper left and right sides, 15 degrees off center. This whole assembly is covered in a matching fabric to the HUG-ME-TIGHT. Once all completed, the sound device is attached to the HUG-ME-TIGHT with buttons around the top of the head in a upside down “U” shape.

**CROSS REFERENCE TO RELATED APPLICATIONS**

[0008] Not Applicable

**STATEMENT REGARDING FEDERALLY SPONSORED RESEARCH OR DEVELOPMENT**

[0009] Not Applicable

**REFERENCE TO SEQUENCE LISTING, A TABLE, OR A COMPUTER PROGRAM LISTING COMPACT DISC APPENDIX**

[0010] Not Applicable

**BACKGROUND OF THE INVENTION**

[0011] “Infants prefer to be wrapped tightly . . . ” A statement broadcast on channel 5 news segment in 2003. The HUG-ME-TIGHT embraces the infant in their natural fetal position. Any previous problems are unknown at this time.

**BRIEF SUMMARY OF THE INVENTION**

[0012] The HUG-ME-TIGHT contains the infant in a fetal position and provides warmth by utilizing the infants body heat and supplies pre-birth sounds. All of which promote more sleeping. More sleep benefits the infant and caregiver.

**BRIEF DESCRIPTION OF THE SEVERAL VIEWS OF THE DRAWINGS**

[0013] A. Complete HUG-ME-TIGHT unit

[0014] a. Front flap opened

[0015] b. Two layer depicted

[0016] c. Three layer depicted



- [0017] d. Front flap closed with sound device attached
- [0018] e. Back
- [0019] f. interfacing flap side with opposite side displayed thru hidden lines
- [0020] B. Sound device cover
  - [0021] g. Individual sound device cover pieces with dimensions
  - [0022] h. Sound device mechanics
  - [0023] i. Shape of hollow tube
  - [0024] j. Hollow tube dimensions
- [0025] C. Small version
  - [0026] aa. Front flap with dimensions
  - [0027] bb. Opposite front side with dimensions
  - [0028] cc. Back with dimensions
  - [0029] dd. Front flap interfacing with dimensions
  - [0030] ee. Opposite front side interfacing with dimensions
- [0031] D. Medium Version
  - [0032] ff. Front flap side with dimensions
  - [0033] gg. Opposite front side with dimensions
  - [0034] hh. Back with dimensions
  - [0035] ii. Front flap interfacing with dimensions
  - [0036] jj. Opposite front side interfacing with dimensions
- [0037] E. Large Version
  - [0038] kk. Front flap with dimensions
  - [0039] ll. Opposite front side with dimensions
  - [0040] mm. Back with dimensions
  - [0041] nn. Front flap interfacing with dimensions
  - [0042] oo. Opposite front side interfacing with dimensions

#### DETAILED DESCRIPTION OF THE INVENTION

[0043] Oval shaped infant apparel opening from the side by an overlapping flap. Velcro secures the flap over the opposite side. The infant is completely contained except for the face. The hole size varies per size of garment, small—3½ inches, medium—5 inches and large—6½ inches.

[0044] 5 pieces are needed to construct the HUG-ME-TIGHT. They are 1 back, 2 front and 2 interfacings. The front pieces may be sewn in reverse to open on either side. The small measurements are; back —8 inches across the ears area, 9 inches across the ankle area and 16 inches long. The front flap side —3 inches down from the top leading to

a 2 inch radius proceeding to 12 inches across the shoulder area, 11 inches across the ankle area, total length 18½ inches. The opposite front side—3 inches down from the top leading to a 1½ inch radius proceeding to 4½ inches across the shoulder area, 5 inches across the hip area proceeding into a 2½ inch radius stopping at ½ the circle. This is joined to a measurement 6½ inches from the bottom, total length is 18½ inches. Front flap side interfacing—1½ inches down from the top, proceeding into a radius 2 inches, leading to a 5 inch by 4 inch box connected to a straight vertical piece with a 2¼ radius on the end. The total length is 16 inches. The opposite front side interfacing—1½ inches down from the top leading to a radius of 1½ inches, leading to straight vertical piece proceeding to a 2½ radius stopping at ½ the circle and intersecting with a 4½ inch piece, from the bottom, total length is 16 inches. Interfacing is sewn to the unsewn edge and folded inside to obtain a finished edge. ALL INTERFACING IS 1½ INCHES THICK

[0045] The medium measurements are; back—10½ inches across the ear area, 11½ inches across the knee area and 22¾ inches long. The front flap side—4½ inches down from the top, leading to a 3½ inch radius proceeding to 14¾ inches across the shoulders area proceeding to 13 inches across the ankles, total length is 24 inches. The opposite front side—4½ inches down from the top leading to a 1½ inch radius proceeding to 5½ inch area by shoulders continuing to 6 inch area by hips proceeding to a 2¼ inch radius stopping ½ circle intersecting with a 7 inch piece, from the bottom. The front flap side interfacing —3 inches down from the top continuing to a 3½ inch radius, connected to a 6 inch by 5 inch box, connected to a straight vertical piece ending in a 2¼ radius. Opposite front side interfacing—3 inches down from the top, leading to a 1½ inch radius connected to a straight vertical piece proceeding to a 2½ inch radius stopping at ½ the circle intersecting with a 5½ inch piece, from the bottom. The large measurements are; back—12 inches across the ear area, 13 inches across the ankle area and 25 inches long. The front flap side —6 inches down from the top, leading to a radius of 5 inches, proceeding to 17 inch across the shoulder area continuing to 15 inches across ankle area, total length is 27 inches. The opposite front side—6 inches down from top, leading to a 1½ inch radius proceeding to 7½ inch area by shoulders proceeding to a 9 inch area across the hip area connected to a 2¼ inch radius intersecting with a 9 inch piece, from the bottom, total length is 27 inches. The front flap interfacing —4½ inches down from the top, leading to a 5 inch radius, connected to a 7 inch by 6 inch box leading to a straight vertical piece, connected to a radius of 2¼ inches, total length is 25½ inches. The opposite front side interfacing—4½ inches down from the top, leading to a radius of 1½ inches connected to a straight vertical piece connected to a radius of 2½ inches, intersected to a 6½ inch piece, from the bottom.

[0046] The HUG-ME-TIGHT is available in three versions, summer, spring/fall and winter. The summer version is made with one layer of 100% cotton flannel, the spring/fall version is made with two layers; one being 100% cotton

flannel and the other fleece, the winter version is made with three layers; one 100% cotton flannel and two layers of fleece.

[0047] The sound device and connections are encased inside a hollow poly foam tube. The components of the sound device consist of; 2 speakers inserted into opposite ends of the tube, both speakers are connected, by wire, to a battery pack and a off/on & timer unit located in the upper left and right sides, 15 degrees off center. This whole assembly is covered in a matching fabric to the HUG-ME-TIGHT. Once all completed, the sound device is attached to the HUG-ME-TIGHT with buttons around the top of the head in a upside down "U" shape.

[0048] After completion, open flap to 180 degrees and lay the infant inside, carefully insert head into top of garment,

pull opposite side to insert shoulders, hips, legs and feet. Take flap side and wrap over infant securing snugly with Velcro closures on opposite side.

1. The HUG-ME-TIGHT claims to reduce wake time for typical infants through design, warmth and sound by simulating the pre-birth environment.

2. The HUG-ME-TIGHT claims to utilize the infants body heat for constant warmth.

3. The HUG-ME-TIGHT claims to perform its utility in three versions; summer, spring/fall and winter and three sizes; small, medium and large.

\* \* \* \* \*