

19



LE GOUVERNEMENT
DU GRAND-DUCHÉ DE LUXEMBOURG
Ministère de l'Économie

11

N° de publication :

LU507611

12

BREVET D'INVENTION

B1

21

N° de dépôt: LU507611

51

Int. Cl.:
F03D 1/00, E04H 9/00, E02D 1/00

22

Date de dépôt: 30/06/2024

30

Priorité:
06/06/2024 CN 202410730840.7

72

Inventeur(s):
MA Peng – China, ZHANG Ce – China, WANG Chao – China, SUN Quanxi – China, SHEN Jia – China, CAO Xiaoran – China, DONG Xianli – China, XIE Bowu – China, DU Hongjie – China, HUANG Heng – China

43

Date de mise à disposition du public: 30/12/2024

47

Date de délivrance: 30/12/2024

73

Titulaire(s):
HUANENG HAMI WIND POWER GENERATION CO., LTD.
– Xinjiang (China)

74

Mandataire(s):
IP SHIELD – 1616 Luxembourg (Luxembourg)

54

TOWER FOR WIND POWER GENERATION.

57

The present invention relates to the technical field of wind power generation and discloses a tower for wind power generation, comprising: a tower body, the tower body including a first tower and a second tower, the first tower being arranged at the lower end of the second tower; a bottom fixing device, arranged at the lower end of the first tower and connected to the bottom end of the first tower; a tower connection device, used for connecting the first tower and the second tower, and fixedly connected to the top end of the first tower and the bottom end of the second tower; a vibration damping device, arranged at the top end of the second tower and fixedly connected to the top end of the second tower. By providing the bottom fixing device, the base can be buried underground and fixed with ground anchor rods, improving the wind resistance of the tower. The tower connection device facilitates the transportation and installation of the tower. The stability of the second tower is ensured by fixing steel cables, and a vibration damping device is arranged at the top of the tower, with springs inside the vibration damping device serving the function of vibration reduction.

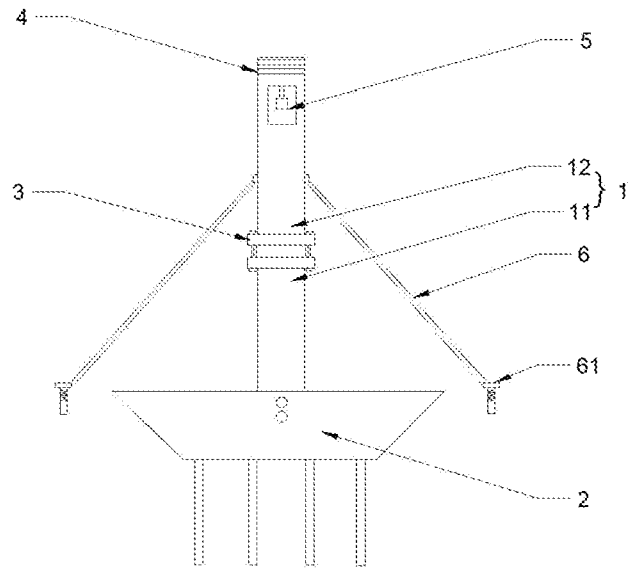

FIG.1

TOWER FOR WIND POWER GENERATION

Technical Field

The present invention belongs to the technical field of wind power generation,
5 particularly relating to a tower for wind power generation.

Background Technology

Energy drives the development of modern society, continuously improving
people's lives. However, traditional energy sources will eventually be depleted.
10 Improving energy structure and utilizing new and renewable energy sources have
become hot topics in the global energy industry. In the development of new energy,
wind energy has seen rapid growth worldwide due to its short construction cycle, low
environmental requirements, abundant reserves, and high utilization rate. Wind
energy is currently the most promising and technically mature new and renewable
15 energy source. Wind power generation is a low-emission, low-pollution, and low-
carbon power production mode that effectively reduces carbon dioxide emissions and
helps mitigate global warming. Thus, it has become an important choice for
sustainable development of electric power in various countries. The utilization of wind
energy is mainly through wind power generation.

20 A wind turbine generator set includes a wind wheel, a generator; the wind wheel
comprises blades, a hub, and reinforcing components. It has functions such as
generating power by rotating blades under wind force and rotating the generator head.
A wind power generation source consists of a wind turbine generator set, a tower
supporting the generator set, a battery charging controller, an inverter, a load
25 controller, a grid-connected controller, and a battery pack.

As a main structure for wind power generation, wind turbines are gradually
developing towards high power. The issue of wind-induced damage under strong
typhoons is becoming increasingly prominent. China, located on the west coast of the
North Pacific Ocean, has many wind farms concentrated in the southeast coastal areas,

which are rich in wind energy resources. However, these areas are affected by dozens of typhoons each year, causing significant loss of life and property, and wind turbines are also damaged by strong typhoons. The tower, as the main structure for wind power generation, can sway under strong winds, potentially collapsing when the swaying is severe, causing unnecessary losses. Moreover, the tower is mostly of an integral structure, making transportation and installation inconvenient.

Currently, one of the urgent problems to solve is how to improve the wind resistance of wind turbine structures. Increasing the wall thickness of the tower can enhance its wind resistance, but it also significantly raises investment costs, increases the structural weight, and complicates construction, leading to a series of potential risks. However, the uncontrollable nature of the tower does not fundamentally improve the stability of the wind turbine system.

Summary of the Invention

The objective of the present invention is to provide a tower for wind power generation to solve at least one of the problems raised in the background technology.

To solve the above technical problems, the specific technical solutions of the present invention are as follows:

In some embodiments of the present application, a tower for wind power generation is provided, including:

A tower body, the tower body comprising a first tower and a second tower, the first tower being arranged at the lower end of the second tower;

A bottom fixing device, arranged at the lower end of the first tower and connected to the bottom end of the first tower;

A tower connection device, used for connecting the first tower and the second tower, fixedly connected to the top end of the first tower and the bottom end of the second tower, making the first tower and the second tower an integral structure;

A vibration damping device, arranged at the top end of the second tower and fixedly connected to the top end of the second tower.

Preferably, in the preferred embodiment of the above tower for wind power

generation, the bottom fixing device includes:

A base, the base being an inverted conical structure, with a groove inside the base;

An annular fixing block, the annular fixing block being set in the groove and fixedly connected to the base;

5 A positioning post, the positioning post being set at the center of the annular fixing block and fixedly connected to the base;

Through holes, the through holes being transversely set on the base, annular fixing block, and the positioning post;

10 Ground anchor rods, the ground anchor rods being multiple in number, passing through and connected to the base.

Preferably, in the preferred embodiment of the above tower for wind power generation, an installation groove is formed between the positioning post and the annular fixing block, the bottom end of the first tower being sleeved on the positioning post and placed in the installation groove, and steel bars passing through the through
15 holes for fixing the first tower.

Preferably, in the preferred embodiment of the above tower for wind power generation, the tower connection device includes:

A first docking plate, the first docking plate being fixedly connected to the top end of the first tower;

20 A first docking tube body, the first docking tube body being fixedly connected to the upper surface of the first docking plate;

A second docking plate, the second docking plate being fixedly connected to the bottom end of the second tower;

25 A second docking tube body, the second docking tube body being fixedly connected to the lower surface of the second docking plate; the first docking tube body and the second docking tube body can be sleeved and clamped.

30 Preferably, in the preferred embodiment of the above tower for wind power generation, the first docking tube body is provided with multiple annular grooves, and the second docking tube body is provided with multiple annular protrusions, the annular protrusions having the same size as the annular grooves, and the first docking

plate and the second docking plate being provided with installation holes. During installation, the annular protrusions are embedded in the annular grooves, and the first docking plate and the second docking plate are connected by bolts through the installation holes.

5 Preferably, in the preferred embodiment of the above tower for wind power generation, the vibration damping device includes:

A vibration damping base plate, the vibration damping base plate being fixedly connected to the top end of the second tower, and the vibration damping base plate being provided with multiple limiting slots;

10 A vibration damping top plate, the vibration damping top plate being provided with multiple limiting blocks, and the vibration damping top plate being connected to the vibration damping base plate by the limiting blocks and the limiting slots;

Springs, each spring having one end connected to the upper surface of the vibration damping base plate and the other end connected to the lower surface of the vibration damping top plate, the springs being multiple in number;

15 A sponge ring, the sponge ring being set between the vibration damping top plate and the vibration damping base plate, with its upper surface connected to the lower surface of the vibration damping top plate and its lower surface connected to the upper surface of the vibration damping base plate, serving a sealing function;

20 A rubber layer, the rubber layer being set on the upper surface of the vibration damping top plate.

Preferably, in the preferred embodiment of the above tower for wind power generation, the vibration damping base plate, vibration damping top plate, and rubber ring are provided with a threading hole at the center, through which the wires of the wind power generator can pass into the tower.

25 Preferably, in the preferred embodiment of the above tower for wind power generation, the second tower is provided with an installation chamber, and a damper is installed in the installation chamber.

30 Preferably, in the preferred embodiment of the above tower for wind power generation, multiple fixing steel cables are connected to the side wall of the second

tower, with the other ends of the fixing steel cables being connected to ground anchors.

From the above technical solutions, it can be seen that, compared to the existing technology, the beneficial effects of the present invention are: by providing a bottom fixing device, the base can be buried underground and fixed with ground anchor rods, and the tower can be fixed with steel bars and positioning posts, improving the wind resistance of the tower. The tower connection device facilitates transportation and installation of the tower, avoiding difficulties due to the large volume and heavy weight of the tower during installation. The stability of the second tower is ensured by fixing steel cables, and a vibration damping device is set at the top of the tower. The springs in the vibration damping device serve the function of vibration reduction, reducing vibrations during the operation of the wind turbine, preventing frequent vibrations of the wind turbine generator set from affecting the service life of the tower over time. The sponge ring serves a sealing function, preventing rainwater from entering the tower and the vibration damping device, and the rubber layer enhances the vibration damping effect.

Description of the Drawings

To more clearly illustrate the technical solutions in the embodiments of the present invention or the existing technology, the accompanying drawings required for the description of the embodiments or the existing technology will be briefly introduced below. Obviously, the drawings described below are only some embodiments of the present invention. For those skilled in the art, other drawings can be obtained based on these drawings without creative efforts.

FIG.1 is a schematic diagram of the main structure of the tower in the embodiment of the present invention;

FIG.2 is a sectional view of the main structure of the tower in the embodiment of the present invention parallel to the front;

FIG.3 is a sectional view of the main structure of the tower in the embodiment of the present invention parallel to the side;

FIG.4 is a sectional view of the bottom fixing device at the position a in FIG.3 in

the embodiment of the present invention;

FIG.5 is a schematic diagram of the structure of the tower connection device in the embodiment of the present invention;

FIG.6 is a schematic diagram of the structure of the vibration damping device in the embodiment of the present invention.

In the drawings:

1. Tower body; 2. Bottom fixing device; 3. Tower connection device; 4. Vibration damping device; 5. Damper; 6. Fixing steel cable;

11. First tower; 12. Second tower;

21. Base; 22. Annular fixing block; 23. Positioning post; 24. Through hole; 25. Ground anchor rod;

31. First docking plate; 32. First docking tube body; 33. Second docking plate; 34. Second docking tube body;

41. Vibration damping base plate; 42. Vibration damping top plate; 43. Spring; 44. Sponge ring; 45. Rubber layer; 46. Threading hole;

411. Limiting slot; 421. Limiting block;

61. Ground anchor.

Specific Embodiments

The specific embodiments of the present invention will be described in further detail below in conjunction with the accompanying drawings and examples. The following examples are intended to illustrate the present invention but are not intended to limit the scope of the present invention.

In the description of the present application, it should be understood that terms such as "center," "upper," "lower," "front," "back," "left," "right," "vertical," "horizontal," "top," "bottom," "inner," and "outer" indicate directions or positional relationships based on the directions or positional relationships shown in the drawings. They are merely for the convenience of describing the present application and simplifying the description, rather than indicating or implying that the devices or elements must have specific orientations, be constructed, and operate in specific

orientations. Therefore, they should not be interpreted as limitations to the present application.

The terms "first" and "second" are used for descriptive purposes only and should not be construed as indicating or implying relative importance or implicitly indicating the number of technical features. Thus, features defined as "first" and "second" may explicitly or implicitly include one or more of these features. In the description of the present application, "multiple" means two or more, unless otherwise specified.

In the description of the present application, it should be noted that unless otherwise explicitly specified and limited, the terms "mounted," "connected," and "coupled" should be broadly understood. For example, they may be fixedly connected, detachably connected, or integrally connected; they may be mechanically connected or electrically connected; they may be directly connected or indirectly connected through an intermediary. Specific meanings of the above terms in the present application can be understood in specific contexts by those skilled in the art.

To better understand the objectives, structure, and functions of the present invention, detailed descriptions are provided below in conjunction with the accompanying drawings.

Referring to FIG.1, a tower for wind power generation according to an embodiment of the present application includes:

A tower body 1, the tower body 1 comprising a first tower 11 and a second tower 12, the first tower 11 being arranged at the lower end of the second tower 12;

A bottom fixing device 2, arranged at the lower end of the first tower 11 and connected to the bottom end of the first tower 11; the bottom fixing device 2 can fix the tower, increasing its wind resistance.

A tower connection device 3, used for connecting the first tower 11 and the second tower 12, fixedly connected to the top end of the first tower 11 and the bottom end of the second tower 12; the tower connection device 3 connects the first tower 11 and the second tower 12, facilitating the disassembly and assembly of the first tower 11 and the second tower 12, and making the transportation of the tower convenient.

A vibration damping device 4, arranged at the top end of the second tower 12 and fixedly connected to the top end of the second tower 12, reducing vibrations during the operation of the wind turbine. Frequent vibrations of the wind turbine generator set can accumulate over time, affecting the service life of the tower and possibly leading to tower collapse due to strength or fatigue failure. Adding the vibration damping device 4 can extend the service life of the tower.

To further optimize the above technical solutions, as shown in FIGS. 2-3, the bottom fixing device 2 includes:

A base 21, the base 21 being an inverted conical structure, with a groove inside the base 21;

An annular fixing block 22, the annular fixing block 22 being set in the groove and fixedly connected to the base 21;

A positioning post 23, the positioning post 23 being set at the center of the annular fixing block 22 and fixedly connected to the base 21;

Through holes 24, the through holes 24 being transversely set on the base 21, annular fixing block 22, and the positioning post 23;

Ground anchor rods 25, the ground anchor rods 25 being multiple in number, passing through and connected to the base 21.

To further optimize the above technical solutions, an installation groove is formed between the positioning post 23 and the annular fixing block 22, the bottom end of the first tower 11 being sleeved on the positioning post 23 and placed in the installation groove, and steel bars passing through the through holes 24 for fixing the first tower 11.

Specifically, during the use of the bottom fixing device 2, tools are used to install the first tower 11 into the installation groove, with the first tower 11 clamped on the outer wall of the positioning post 23, and the annular fixing block 22 fixing the tower. After the first tower 11 is installed in the installation groove, steel bars are inserted into the through holes 24, sequentially passing through the through holes in the base 21, the annular fixing block 22, and the positioning post 23. After installation, the base 21 is placed in a previously excavated underground trench, and multiple ground anchor

rods 25 are inserted deep into the soil. Concrete is filled in the groove, making the upper surface of the annular fixing block 22 flush with the ground, thereby completing the fixing of the tower. The base 21, being an inverted conical structure, and the annular fixing block 22 matching the shape of the base 21, better fix the tower, further increasing its stability.

To further optimize the above technical solutions, as shown in FIG.4, the tower connection device 3 includes:

A first docking plate 31, the first docking plate 31 being fixedly connected to the top end of the first tower 11;

10 A first docking tube body 32, the first docking tube body 32 being fixedly connected to the upper surface of the first docking plate 31;

A second docking plate 33, the second docking plate 33 being fixedly connected to the bottom end of the second tower 12;

15 A second docking tube body 34, the second docking tube body 34 being fixedly connected to the lower surface of the second docking plate 33; the first docking tube body 32 and the second docking tube body 34 can be sleeved and clamped.

To further optimize the above technical solutions, the first docking tube body 32 is provided with multiple annular grooves, and the second docking tube body 34 is provided with multiple annular protrusions, the annular protrusions having the same size as the annular grooves, and the first docking plate 31 and the second docking plate 20 33 being provided with installation holes. During installation, the annular protrusions are embedded in the annular grooves, and the first docking plate 31 and the second docking plate 33 are connected by bolts through the installation holes.

Specifically, during the use of the tower connection device, the annular protrusions of the second docking tube body 34 are installed in the annular grooves of the first docking tube body 32, realizing the preliminary installation of the first tower body 11 and the second tower body 12. Bolts are used to fixedly connect the first docking plate 31 and the second docking plate 33 through the installation holes, completing the installation. Multiple bolts are inserted into the installation holes to connect the docking plates at both ends, and are fixed with nuts on the other end, 30

facilitating the disassembly and assembly of the tower bodies at both ends.

To further optimize the above technical solutions, as shown in FIG.5, the vibration damping device 4 includes:

5 A vibration damping base plate 41, the vibration damping base plate 41 being fixedly connected to the top end of the second tower 12, and the vibration damping base plate 41 being provided with multiple limiting slots 411;

10 A vibration damping top plate 42, the vibration damping top plate 42 being provided with multiple limiting blocks 421, and the vibration damping top plate 42 being connected to the vibration damping base plate 41 by the limiting blocks 421 and the limiting slots 411;

Springs 43, each spring 43 having one end connected to the upper surface of the vibration damping base plate 41 and the other end connected to the lower surface of the vibration damping top plate 42, the springs 43 being multiple in number;

15 A sponge ring 44, the sponge ring 44 being set between the vibration damping top plate 42 and the vibration damping base plate 41, with its upper surface connected to the lower surface of the vibration damping top plate 42 and its lower surface connected to the upper surface of the vibration damping base plate 41, serving a sealing function;

20 A rubber layer 45, the rubber layer 45 being set on the upper surface of the vibration damping top plate 42.

To further optimize the above technical solutions, the vibration damping base plate 41, vibration damping top plate 42, and rubber ring 45 are provided with a threading hole 46 at the center.

25 Specifically, during the use of the vibration damping device 4, the vibration damping base plate 41 and the vibration damping top plate 42 are installed on the tower, with multiple springs 43 connected between the vibration damping base plate 41 and the vibration damping top plate 42, serving a shock absorption function. The limiting blocks 421 at the lower end of the vibration damping top plate 42 are clamped in the limiting slots 411 at the upper end of the base plate, increasing the stability of
30 the connection between the top plate and the base plate. The lower parts of the

limiting blocks 421 are clamped in the lower parts of the limiting slots 411, and the height of the lower parts of the limiting slots 411 is higher than the height of the lower parts of the limiting blocks 421, ensuring the shock absorption function of the springs 43. The edges of the base plate and the top plate are connected by a sponge ring 44, serving a sealing function and preventing rainwater from entering the tower and the vibration damping device 4. A rubber layer 45 is set on the upper surface of the vibration damping top plate 42, enhancing the vibration damping effect.

To further optimize the above technical solutions, the second tower 12 is provided with an installation chamber, and a damper 5 is installed in the installation chamber. The damper 5 can improve the stability of the tower body, preventing excessive swaying.

To further optimize the above technical solutions, multiple fixing steel cables 6 are connected to the side wall of the second tower 12, with the other ends of the fixing steel cables 6 connected to ground anchors 61. The fixing steel cables 6 are connected to the side wall of the second tower 12, and the fixing steel cables 6 are tightened. The other ends of the connected ground anchors 61 are driven into the ground. Four sets of fixing steel cables 6 are set oppositely on the side wall of the second tower 12. The tension between the four sets of steel cables acts mutually, realizing the fixing of the second tower body 12 and preventing excessive swaying.

Working principle: Tools are used to install the first tower 11 into the installation groove, with the first tower 11 clamped on the outer wall of the positioning post 23. The annular fixing block 22 fixes the tower. After the first tower 11 is installed in the installation groove, steel bars are inserted into the through holes 24, sequentially passing through the through holes in the base 21, the annular fixing block 22, and the positioning post 23. After installation, the base 21 is placed in a previously excavated underground trench. Multiple ground anchor rods 25 are inserted deep into the soil. Concrete is filled in the groove, making the upper surface of the annular fixing block 22 flush with the ground, completing the fixing of the tower. The base 21, being an inverted conical structure, and the annular fixing block 22 matching the shape of the base 21, better fix the tower, further increasing its stability, completing the first step

of tower installation. The annular protrusions of the second docking tube body 34 are installed in the annular grooves of the first docking tube body 32, realizing the preliminary installation of the first tower body 11 and the second tower body 12. Bolts are used to fixedly connect the first docking plate 31 and the second docking plate 33 through the installation holes, completing the installation. Multiple bolts are inserted into the installation holes to connect the docking plates at both ends, and are fixed with nuts on the other end, facilitating the disassembly and assembly of the tower bodies at both ends, completing the installation of the first tower and the second tower. The second tower is further fixed by fixing steel cables 6. The fixing steel cables 6 are connected to the side wall of the second tower 12. The fixing steel cables 6 are tightened. The other ends of the connected ground anchors 61 are driven into the ground. Four sets of fixing steel cables 6 are set oppositely on the side wall of the second tower 12. The tension between the four sets of steel cables acts mutually, realizing the fixing of the second tower body 12 and preventing excessive swaying. The vibration damping device 4 includes the installation of the vibration damping base plate 41 and the vibration damping top plate 42 at the top of the second tower 12, with multiple springs 43 connected between the vibration damping base plate 41 and the vibration damping top plate 42, serving a shock absorption function. The limiting blocks 421 at the lower end of the vibration damping top plate 42 are clamped in the limiting slots 411 at the upper end of the base plate, increasing the stability of the connection between the top plate and the base plate. The lower parts of the limiting blocks 421 are clamped in the lower parts of the limiting slots 411, and the height of the lower parts of the limiting slots 411 is higher than the height of the lower parts of the limiting blocks 421, ensuring the shock absorption function of the springs 43. The edges of the base plate and the top plate are connected by a sponge ring 44, serving a sealing function and preventing rainwater from entering the tower and the vibration damping device 4. A rubber layer 45 is set on the upper surface of the vibration damping top plate 42, enhancing the vibration damping effect. By providing the bottom fixing device 2, the base 21 can be buried underground and fixed with ground anchor rods 25, improving the wind resistance of the tower. The tower connection

device 3 facilitates the transportation and installation of the tower. The stability of the second tower 12 is ensured by fixing steel cables 6. A vibration damping device 4 is set at the top of the tower, with springs 43 inside the vibration damping device 4 serving the function of vibration reduction. The sponge ring 44 serves a sealing function, preventing rainwater from entering the tower and the vibration damping device 4. The rubber layer 45 enhances the vibration damping effect.

The embodiments of this specification are described in a progressive manner. Each embodiment focuses on explaining the differences from other embodiments. The same or similar parts between the embodiments are referred to each other. For the devices disclosed in the embodiments, since they correspond to the methods disclosed in the embodiments, the description is relatively simple. The relevant parts are referred to in the method section for description.

The above description of the disclosed embodiments enables those skilled in the art to realize or use the invention. Various modifications to these embodiments will be apparent to those skilled in the art, and the general principles defined herein can be applied to other embodiments without departing from the spirit or scope of the invention. Thus, the present invention is not intended to be limited to the embodiments shown herein, but is to be accorded the widest scope consistent with the principles and novel features disclosed herein.

CLAIMS

1. A tower for wind power generation, wherein it comprises:

A tower body (1), the tower body (1) comprising a first tower (11) and a second tower (12), the first tower (11) being arranged at the lower end of the second tower
5 (12);

A bottom fixing device (2), arranged at the lower end of the first tower (11) and connected to the bottom end of the first tower (11);

A tower connection device (3), fixedly connected to the top end of the first tower (11) and the bottom end of the second tower (12), making the first tower (11) and the
10 second tower (12) an integral structure;

A vibration damping device (4), located at the top end of the second tower (12) and fixedly connected to the top end of the second tower (12).

2. The tower for wind power generation according to claim 1, wherein the bottom
15 fixing device (2) comprises:

A base (21), the base (21) being an inverted conical structure, with a groove inside the base (21);

An annular fixing block (22), the annular fixing block (22) being set in the groove and fixedly connected to the base (21);

20 A positioning post (23), the positioning post (23) being set at the center of the annular fixing block (22) and fixedly connected to the base (21);

The base (21), the annular fixing block (22), and the positioning post (23) are all provided with corresponding through holes (24);

25 Ground anchor rods (25), the ground anchor rods (25) being multiple in number, passing through and connected to the base (21).

3. The tower for wind power generation according to claim 2, wherein an installation groove is formed between the positioning post (23) and the annular fixing block (22), the bottom end of the first tower (11) being sleeved on the positioning post

(23) and placed in the installation groove;

The bottom end of the first tower (11) is provided with through holes (24) corresponding to the base (21), the annular fixing block (22), and the positioning post (23), and steel bars pass through the through holes (24) in the base (21), the annular
5 fixing block (22), the first tower (11), and the positioning post (23) for fixing the first tower (11).

4. The tower for wind power generation according to claim 1, wherein the tower connection device (3) comprises:

10 A first docking plate (31), the first docking plate (31) being fixedly connected to the top end of the first tower (11);

A first docking tube body (32), the first docking tube body (32) being fixedly connected to the upper surface of the first docking plate (31);

15 A second docking plate (33), the second docking plate (33) being fixedly connected to the bottom end of the second tower (12);

A second docking tube body (34), the second docking tube body (34) being fixedly connected to the lower surface of the second docking plate (33); the first docking tube body (32) and the second docking tube body (34) can be sleeved and clamped.

20 5. The tower for wind power generation according to claim 4, wherein the first docking tube body (32) is provided with multiple annular grooves, and the second docking tube body (34) is provided with multiple annular protrusions, the annular protrusions having the same size as the annular grooves, the first docking plate (31) and the second docking plate (33) being provided with installation holes, wherein
25 during installation, the annular protrusions are embedded in the annular grooves, and the first docking plate (31) and the second docking plate (33) are connected by bolts through the installation holes.

30 6. The tower for wind power generation according to claim 1, wherein the vibration damping device (4) comprises:

A vibration damping base plate (41), the vibration damping base plate (41) being fixedly connected to the top end of the second tower (12), the vibration damping base plate (41) being provided with multiple limiting slots (411);

5 A vibration damping top plate (42), the vibration damping top plate (42) being provided with multiple limiting blocks (421) adapted to the limiting slots (411), the vibration damping top plate (42) being connected to the vibration damping base plate (41) by the limiting blocks (421) and the limiting slots (411), with a gap between the vibration damping base plate (41) and the vibration damping top plate (42);

10 Multiple springs (43), each spring (43) having one end connected to the upper surface of the vibration damping base plate (41) and the other end connected to the lower surface of the vibration damping top plate (42);

15 A sponge ring (44), the sponge ring (44) being set between the vibration damping top plate (42) and the vibration damping base plate (41), with its upper surface connected to the lower surface of the vibration damping top plate (42) and its lower surface connected to the upper surface of the vibration damping base plate (41);

A rubber layer (45), the rubber layer (45) being set on the upper surface of the vibration damping top plate (42).

20 7. The tower for wind power generation according to claim 6, wherein the vibration damping base plate (41), the vibration damping top plate (42), and the rubber layer (45) are provided with a threading hole (46) at the center, through which the wires of the wind power generator can pass into the tower.

25 8. The tower for wind power generation according to claim 1, wherein an installation chamber is provided on the second tower (12), and a damper (5) is installed in the installation chamber.

30 9. The tower for wind power generation according to claim 1, wherein multiple fixing steel cables (6) are connected to the side wall of the second tower (12), with the other ends of the fixing steel cables (6) being connected to ground anchors (61).

REVENDICATIONS

1. Un mât pour la production d'énergie éolienne, caractérisé par le fait qu'il comprend :

5 Un corps de mât (1), comprenant une première section de mât (11) et une deuxième section de mât (12), la première section de mât (11) étant disposée à l'extrémité inférieure de la deuxième section de mât (12) ;

Un dispositif de fixation de la base (2), disposé à l'extrémité inférieure de la première section de mât (11) et relié à l'extrémité inférieure de la première section de mât (11) ;

10

Un dispositif de connexion du mât (3), dont les deux extrémités sont respectivement fixées à l'extrémité supérieure de la première section de mât (11) et à l'extrémité inférieure de la deuxième section de mât (12), formant ainsi une structure intégrée entre la première section de mât (11) et la deuxième section de mât (12) ;

15 Un dispositif anti-vibration (4), situé à l'extrémité supérieure de la deuxième section de mât (12) et fixé à l'extrémité supérieure de la deuxième section de mât (12).

2. Selon la revendication 1, un mât pour la production d'énergie éolienne, caractérisé par le fait que le dispositif de fixation de la base (2) comprend :

20 Une base (21), la base (21) ayant une structure de cône inversé, avec une rainure formée à l'intérieur de la base (21) ;

Un bloc de fixation annulaire (22), le bloc de fixation annulaire (22) étant disposé dans la rainure et fixé à la base (21) ;

Un pilier de positionnement (23), le pilier de positionnement (23) étant disposé au centre du bloc de fixation annulaire (22) et fixé à la base (21) ;

25

La base (21), le bloc de fixation annulaire (22) et le pilier de positionnement (23) étant tous percés de plusieurs trous traversants correspondants (24) ;

Des ancrages (25), les ancrages (25) étant en nombre multiple et étant reliés à travers la base (21).

3. Selon la revendication 2, un mât pour la production d'énergie éolienne, caractérisé par le fait qu'une rainure de montage est formée entre le pilier de positionnement (23) et le bloc de fixation annulaire (22), l'extrémité inférieure de la première section de mât (11) étant enfilée sur le pilier de positionnement (23) et placée dans la rainure de montage ;

L'extrémité inférieure de la première section de mât (11) est percée de trous traversants (24) correspondant à la base (21), au bloc de fixation annulaire (22) et au pilier de positionnement (23), et des barres d'armature traversent les trous traversants (24) de la base (21), du bloc de fixation annulaire (22), de la première section de mât (11) et du pilier de positionnement (23) pour fixer la première section de mât (11).

4. Selon la revendication 1, un mât pour la production d'énergie éolienne, caractérisé par le fait que le dispositif de connexion du mât (3) comprend :

Une première plaque de raccordement (31), la première plaque de raccordement (31) étant fixée à l'extrémité supérieure de la première section de mât (11) ;

Un premier tube de raccordement (32), le premier tube de raccordement (32) étant fixé à la surface supérieure de la première plaque de raccordement (31) ;

Une deuxième plaque de raccordement (33), la deuxième plaque de raccordement (33) étant fixée à l'extrémité inférieure de la deuxième section de mât (12) ;

Un deuxième tube de raccordement (34), le deuxième tube de raccordement (34) étant fixé à la surface inférieure de la deuxième plaque de raccordement (33), le premier tube de raccordement (32) et le deuxième tube de raccordement (34) pouvant être emboîtés ensemble.

5. Selon la revendication 4, un mât pour la production d'énergie éolienne, caractérisé par le fait que le premier tube de raccordement (32) est pourvu de plusieurs rainures annulaires et que le deuxième tube de raccordement (34) est pourvu de plusieurs bosses annulaires, les bosses annulaires ayant la même taille que

les rainures annulaires, les première plaque de raccordement (31) et deuxième plaque de raccordement (33) étant pourvues de trous de montage ; lors du montage, les bosses annulaires sont insérées dans les rainures annulaires, et les première plaque de raccordement (31) et deuxième plaque de raccordement (33) sont fixées ensemble à l'aide de trous de montage et de boulons.

6. Selon la revendication 1, un mât pour la production d'énergie éolienne, caractérisé par le fait que le dispositif anti-vibration (4) comprend :

Une plaque de base anti-vibration (41), la plaque de base anti-vibration (41) étant fixée à l'extrémité supérieure de la deuxième section de mât (12), la plaque de base anti-vibration (41) étant pourvue de plusieurs rainures de limitation (411) ;

Une plaque supérieure anti-vibration (42), la plaque supérieure anti-vibration (42) étant pourvue de plusieurs blocs de limitation (421) adaptés aux rainures de limitation (411), la plaque supérieure anti-vibration (42) étant reliée à la plaque de base anti-vibration (41) par les blocs de limitation (421) et les rainures de limitation (411), un espace étant prévu entre la plaque de base anti-vibration (41) et la plaque supérieure anti-vibration (42) ;

Des ressorts (43), en nombre multiple, chaque ressort (43) ayant une extrémité reliée à la surface supérieure de la plaque de base anti-vibration (41) et l'autre extrémité reliée à la surface inférieure de la plaque supérieure anti-vibration (42) ;

Un anneau en mousse (44), l'anneau en mousse (44) étant disposé entre la plaque supérieure anti-vibration (42) et la plaque de base anti-vibration (41), sa surface supérieure étant reliée à la surface inférieure de la plaque supérieure anti-vibration (42) et sa surface inférieure étant reliée à la surface supérieure de la plaque de base anti-vibration (41) ;

Une couche de caoutchouc (45), la couche de caoutchouc (45) étant disposée sur la surface supérieure de la plaque supérieure anti-vibration (42).

7. Selon la revendication 6, un mât pour la production d'énergie éolienne, caractérisé par le fait qu'un trou de passage de câble (46) est disposé au centre de la

plaque de base anti-vibration (41), de la plaque supérieure anti-vibration (42) et de la couche de caoutchouc (45), permettant le passage des câbles de la génératrice éolienne dans le mât.

5 8. Selon la revendication 1, un mât pour la production d'énergie éolienne, caractérisé par le fait qu'une chambre d'installation est disposée sur la deuxième section de mât (12), un amortisseur (5) étant installé dans la chambre d'installation.

10 9. Selon la revendication 1, un mât pour la production d'énergie éolienne, caractérisé par le fait que plusieurs câbles d'acier fixes (6) sont reliés à la paroi latérale de la deuxième section de mât (12), l'autre extrémité des câbles d'acier fixes (6) étant reliée à des pieux de sol (61).

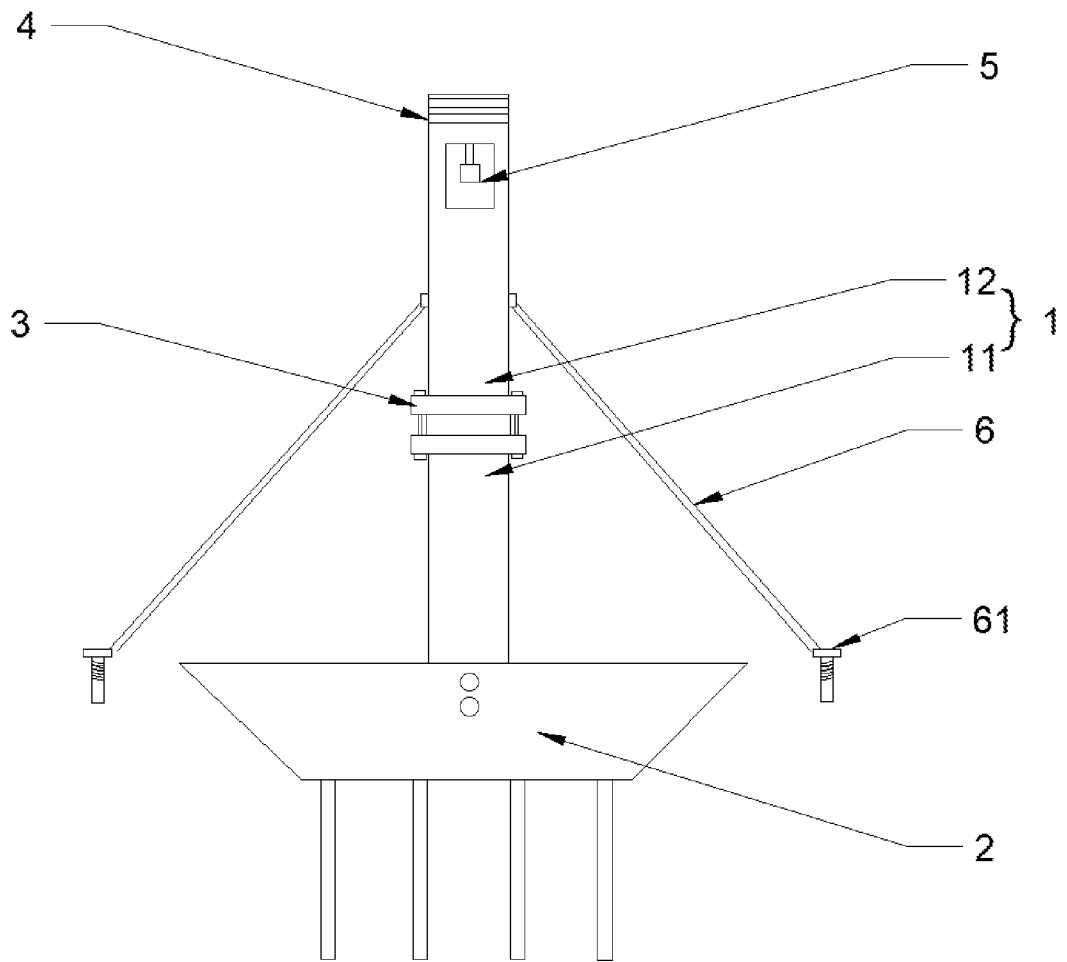
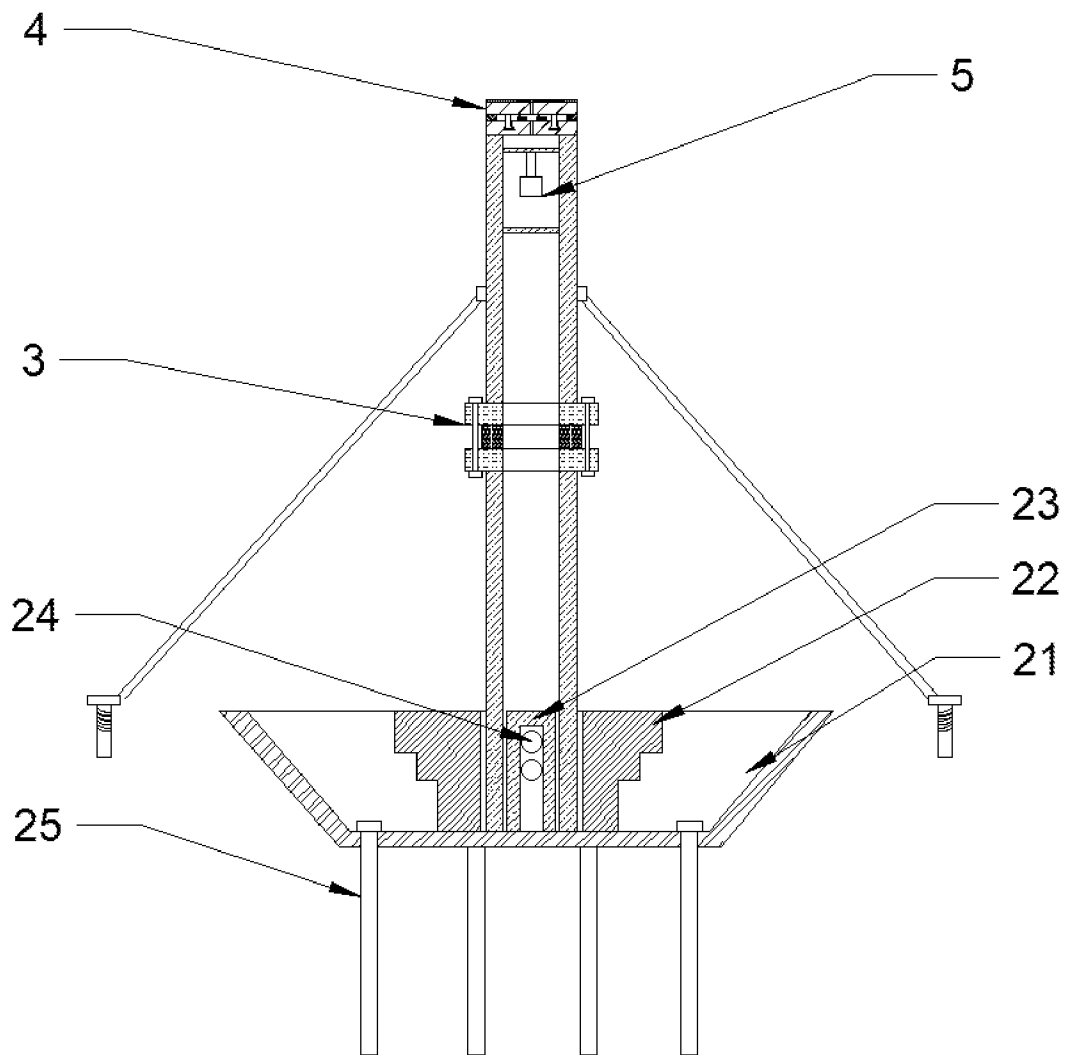

FIG.1



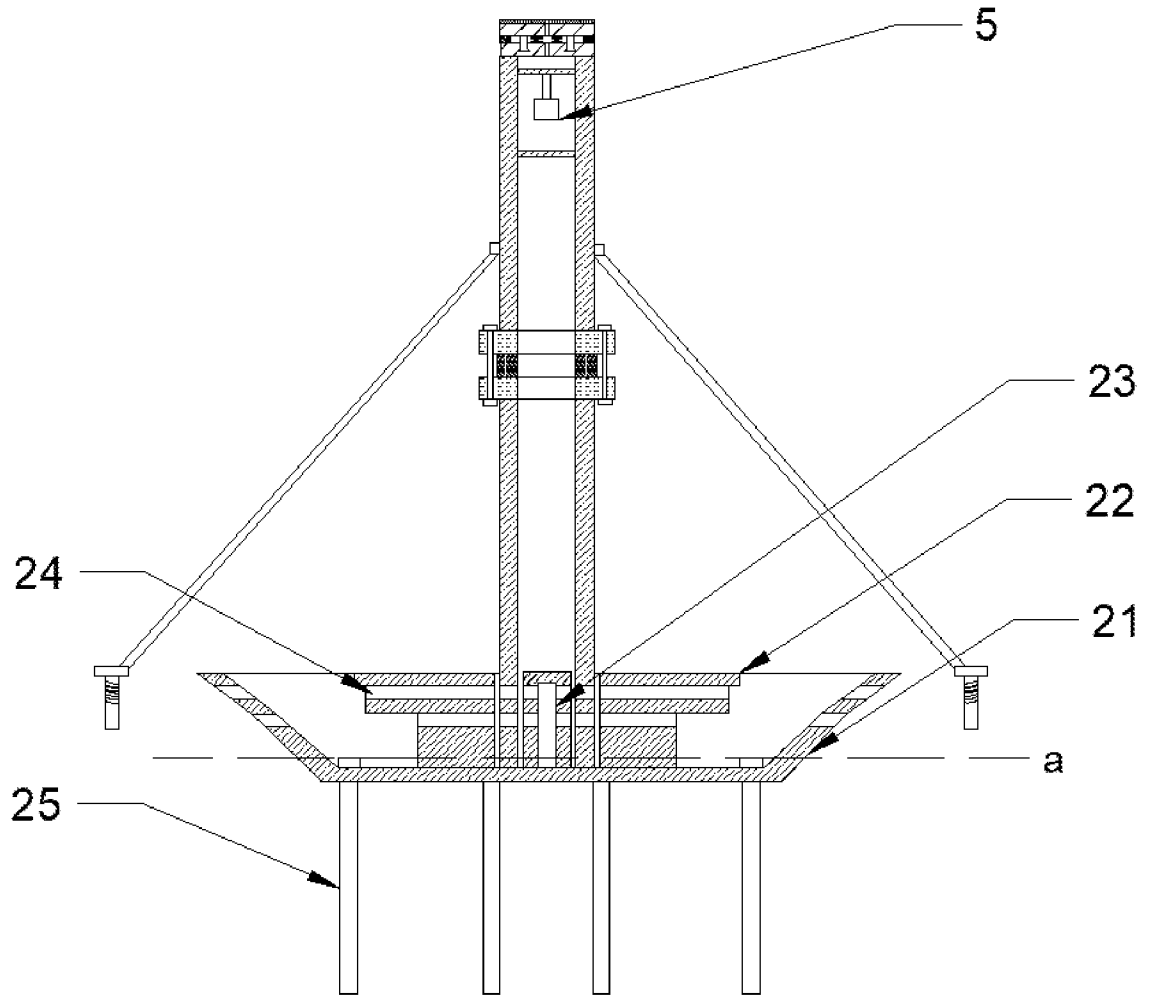

FIG.3

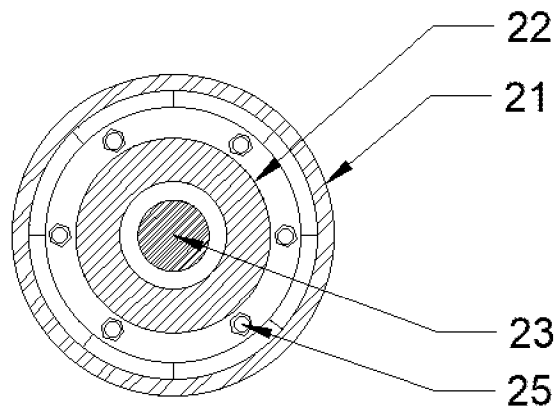

FIG. 4

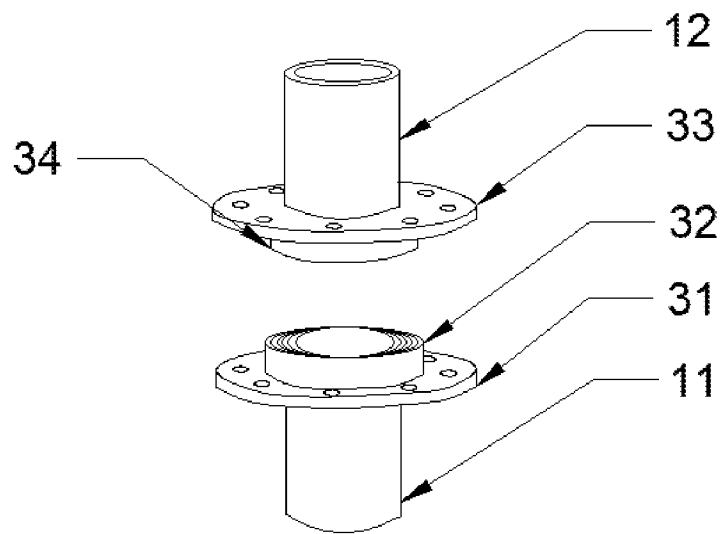

FIG. 5

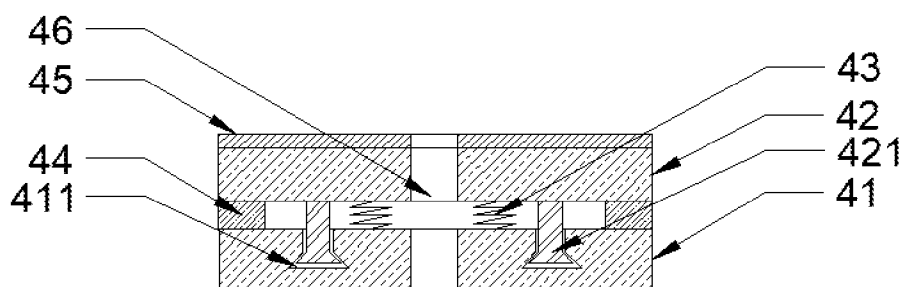

FIG.6