

19



Europäisches Patentamt
European Patent Office
Office européen des brevets



11 Publication number:

0 213 962 B1

12

EUROPEAN PATENT SPECIFICATION

45 Date of publication of patent specification: **04.09.91** 51 Int. Cl.⁵: **D01H 15/00**

21 Application number: **86306816.9**

22 Date of filing: **03.09.86**

54 **Roving-piecing method in spinning frame and roving-piecing head for carrying out said method.**

30 Priority: **04.09.85 JP 193919/85**
04.09.85 JP 193920/85

43 Date of publication of application:
11.03.87 Bulletin 87/11

45 Publication of the grant of the patent:
04.09.91 Bulletin 91/36

64 Designated Contracting States:
CH DE FR GB IT LI

56 References cited:
EP-A- 0 124 662
DE-A- 3 211 040
DE-A- 3 342 858

73 Proprietor: **HOWA MACHINERY LIMITED**
32-3, Meieki 2-chome Nakamura-ku
Nagoya-shi Aichi(JP)

72 Inventor: **Kawasaki, Yoshio**
1433, Zenzaemon
Fujieda-shi Shizuoka(JP)
Inventor: **Horibe, Tatutake**
15, Hori
Toyama-shi Toyama(JP)
Inventor: **Yamada, Kazuo**
3843-58, Hattanda Okuda-cho
Inazawa-shi Aichi(JP)

74 Representative: **Arthur, Bryan Edward et al**
Withers & Rogers 4 Dyer's Buildings Holborn
London EC1N 2JT(GB)

EP 0 213 962 B1

Note: Within nine months from the publication of the mention of the grant of the European patent, any person may give notice to the European Patent Office of opposition to the European patent granted. Notice of opposition shall be filed in a written reasoned statement. It shall not be deemed to have been filed until the opposition fee has been paid (Art. 99(1) European patent convention).

Description

BACKGROUND OF THE INVENTION

(1) Field of the Invention

The present invention relates to a roving-piecing method in a spinning frame and a roving-piecing head for use in carrying out said method. More particularly, the present invention relates to a method in which, when the amount of a roving on a bobbin suspended from a bobbin hanger in a spinning frame is reduced, and roving exchange become necessary, the roving of this small bobbin is pieced with a roving of a full bobbin, with which the small bobbin is to be exchanged, and also to a roving-piecing head for use in carrying out this method.

(2) Description of the Related Art

When a roving bobbin suspended from a bobbin hanger of a spinning frame becomes empty or small, it is necessary to exchange this roving bobbin with a full bobbin and piece the roving of the small bobbin with the roving of the full bobbin or insert the roving of the full bobbin into a draft zone of the spinning frame.

In a spinning mill, automation progresses at respective steps to enhance the labor-saving effect, and this automation is required even at the above-mentioned roving exchange operation in the spinning frame and the accompanying roving-piecing operation.

As a means for the automation of the roving exchange operation, a method is known in which a small bobbin suspended from a bobbin hanger of a spinning frame is exchanged with a full bobbin mounted on a bobbin hanger of a spare rail by a roving exchanger running along a machine stand of the spinning frame, as disclosed, for example, in Japanese Unexamined Patent Publication No. 60-71724.

As is well-known, the roving on the roving bobbin is only slightly twisted and is very downy, and the roving is broken by only lightly stretching the same. Since mechanical piecing of such a weak roving is difficult, the roving-piecing operation must be manually performed, and this is a hindrance to the enhancement of the labor-saving effect in the roving exchange operation including the roving-piecing operation.

EP-A-124,662 discloses a roving-piecing method for use in a roving exchange operation on a spinning frame when the wound diameter of a roving bobbin suspended from a bobbin hanger and from which a roving is withdrawn becomes small, wherein the end of a roving or a rotatably

supported full bobbin to be exchanged with the small bobbin is taken out, said end of the roving is held and guided above a trumpet, said end of the roving is piled on the roving of the small bobbin during spinning, the end of the roving of the full bobbin is released, and then the roving of the small bobbin is cut to effect roving-piecing.

SUMMARY OF INVENTION

It is a primary object of the present invention to provide a roving-piecing method in which automation of the roving-piecing operation in a spinning frame, which has previously been carried out manually, can be automatically accomplished within a short time by a simple operation.

A secondary object of the present invention is to provide a tool for performing the roving-piecing operation, that is, a roving-piecing head.

In one aspect, this invention provides a roving piecing method as disclosed in EP-A-124,662, characterised by moving a sucking opening of an end take-out nozzle to a position opposite to a periphery of the full bobbin, rotating the full bobbin in the rewinding direction, applying a suction force to the end take-out nozzle to suck the free end of the roving into the sucking opening of the end take-out nozzle, moving the sucking opening of the end take-out nozzle to a position over a roving-piecing head to draw out a portion of the roving between the full bobbin and the sucking opening of the moved end take-out nozzle and guide the drawn-out portion of the roving to a roving guide groove of the roving-piecing head, operating a roving holding means to hold the guided portion of the roving in the roving guide groove, moving the roving-piecing head to an upper position away from the trumpet to put a roving withdrawn from a small bobbin into the roving guide groove of the roving-piecing head and to pile with the portion of the roving of the full bobbin in the roving guide groove, releasing the holding of the roving of the full bobbin in the roving-piecing head so that the free end of the roving of the full bobbin can advance to a draft zone with the roving of the small bobbin before cutting the roving of the small bobbin at a position upstream of the trumpet, whereby the free end of the full bobbin is automatically pieced with the roving of the small bobbin.

In the practise of the above-mentioned roving-piecing operation, the roving-piecing method preferably comprises the step of hanging the pieced roving withdrawn from the full bobbin on a roving guide.

In another aspect the invention provides a roving-piecing head characterised by comprising a body having a roving guide groove formed in a top end portion thereof, a roving holding lever mounted

on the body which is capable of reciprocating across said guide groove and roving holding members arranged on the body on both sides of said guide groove to co-operate with the roving holding lever for holding a roving.

Preferred embodiments are defined in the dependent claims.

BRIEF DESCRIPTION OF THE DRAWINGS

Figure 1 is a front view showing an example of a roving exchanger for use in carrying out the roving-piecing method of the present invention; Figure 2 is a sectional side view showing the main portion of the roving exchange shown in Figure 1;

Figure 3 is a sectional view illustrating the relationship between the roving exchanger and the spinning frame;

Figure 4 is a plan view illustrating the correspondence relationship between the bobbin exchange head of the roving exchanger and the spinning frame;

Figure 5 is a sectional partial view of the roving exchanger illustrating a mechanism for moving a full bobbin exchange head forward and backward;

Figure 6 is a sectional partial view of the roving exchanger illustrating end take-out, roving-piecing, and roving hanging mechanisms;

Figure 7 is a sectional partial view of the roving exchanger illustrating an end take-out nozzle operating mechanism;

Figure 8 is a sectional partial view of the roving exchanger illustrating a roving-piecing head operating mechanism;

Figure 9 is a sectional partial view of the roving exchanger illustrating a roving-hanging plate operating mechanism;

Fig. 10 is a diagram illustrating the end of a roving on a full bobbin when the roving is transferred from a roving frame to the roving exchanger;

Fig. 11 is a plan view illustrating a peg rotating mechanism of the full bobbin exchange head;

Fig. 12 is a front view showing the section taken along the line XII-XII in Fig. 11;

Fig. 13 is a view showing the axial section of a peg of the roving exchanger;

Fig. 14 is a plan view showing an example of the roving-piecing head according to the present invention;

Fig. 15 is a side view of the roving-piecing head shown in Fig. 14;

Fig. 16-(A) is a front view of another example of the roving-piecing head, and Fig. 16-(B) is a side view thereof;

Fig. 17-(A) is a front view of still another exam-

ple of the roving-piecing head, and Fig. 17-(B) is a side view thereof;

Fig. 18 is a side view showing the roving-piecing head shown in Fig. 17 in the state where a roving guide member is swung;

Fig. 19 is a plan view showing a mechanism for operating a roving holding lever of the roving-piecing head;

Fig. 20-(A) is a plan view showing a roving guide and Fig. 20-(B) is a front view thereof; and

Fig. 21-(1) through 21-(15) illustrate the operations of the roving exchanger in sequence.

DESCRIPTION OF THE PREFERRED EMBODIMENTS

Preferred embodiments of the present invention will now be described by way of example only with reference to the accompanying drawings.

The roving-piecing operation in a spinning frame according to the present invention is carried out when the wound diameter of a roving bobbin attached to a bobbin hanger arranged along a row of spindles of the spinning frame is reduced and this small bobbin is exchanged with a full bobbin suspended from a spare bobbin hanger supported on a spare rail arranged above and before a front bobbin hanger of a creel of the spinning frame. Accordingly, the roving-piecing operation is a part of the roving exchange operation in a broad sense, which comprises the operation of exchanging the small bobbin with the full bobbin, the operation of piecing the roving of the full bobbin with the roving of the small bobbin from which the roving is withdrawn, and the related operation of hanging the roving of the full bobbin on a roving guide.

The above-mentioned roving exchange operation in a broad sense is carried out by using a roving exchanger 50 shown in Fig. 1 (front view) and Fig. 2 (side view). As shown in Fig. 3, the roving exchanger 50 is arranged on both sides of the machine stand of the spinning frame and movable along a row of spindles of the spinning frame.

As shown in Fig. 3, creel pillars 4 of a spinning creel are vertically arranged at appropriate intervals in the longitudinal direction of the machine stand 3 in the central portion of the machine stand 3 of the spinning frame. Above a draft zone 5, bobbin hangers 19 and 20 are supported on two front and rear rails 11 and 12 supported on the creel pillars 4 by a supporting bracket 18, a supporting bracket 13, and a hanging lever 14. A small bobbin 1c and a medium bobbin 1b are suspended from the bobbin hangers 19 and 20. The bobbin hangers 19 and 20 are arranged so that they confront each other at every two pitches of the draft zone 5, that is, at every two spindles, as indicated by the positions of the small bobbin 1c and medium bobbin 1b in Fig.

4. Hereinafter, the bobbin hanger 19 of the front rail 11 will be called the front bobbin hanger 19 and the bobbin hanger 20 of the rear rail 12 will be called the rear bobbin hanger 20. As shown in Fig. 3, a substantially annular roving guide 2 is supported on the creel pillar 4 below the intermediate portion between the front and rear bobbin hangers 19 and 20 by using a supporting lever 9. The roving guide 2 is formed to have an annular shape having an opening 2c and an inwardly projecting ridge 2a on the side confronting the opening 2c, as shown in Fig. 20-(A), and upright nails 2b are formed on both sides adjacent to the opening 2c, as shown in Fig. 20-(B). The nails 2b may be inwardly projected. The ridge 2a serves to separate rovings fed from the front bobbin 1c and rear bobbin 1b, and the nails 2b serve to hang the roving of the full bobbin on the roving guide after the roving-piecing operation.

A spare rail 15 attached to the top end portion of the supporting bracket 13 is laid out along the longitudinal direction of the machine stand before and above the front bobbin hanger 19. The spare rail 15 is formed in a hollow columnar shape having a Γ -shape section in which the lower side is open, and a bobbin carriage 17 is inserted into the spare rail 15 from this opening so that the bobbin carriage 17 can go in and out and can move along the spare rail 15. The bobbin carriage 17 has a spare hanger 24, and as shown in Fig. 3, the full bobbin 1a is suspended from this bobbin hanger 24, and after the roving exchange operation in a broad sense, described hereinafter, the small bobbin 1c can be suspended from the bobbin hanger 24.

The roving exchange operation including the roving-piecing operation is carried out between the small bobbin 1c of the front bobbin hanger 19 and the full bobbin 1a of the spare bobbin hanger 15, as shown in Fig. 3. After the roving exchange operation, the roving R of the full bobbin 1a of the front bobbin hanger 19 is fed to a back roller 5a of the draft zone 5 through the roving guide 2 and trumpet 6 and is twisted into a yarn by a spindle 25. Reference numeral 7 represents a supporting rod for a top arm (not shown) for supporting a plurality of top rollers of the draft zone 5. As spinning of the yarn progresses, the roving on the full bobbin 1a of the front bobbin hanger 19 is consumed and the full bobbin is changed to a medium bobbin, while the roving on the medium bobbin 1b of the rear bobbin hanger 20 is consumed and the medium bobbin is changed to a small bobbin. At this time, the front bobbin hanger 19 and rear bobbin hanger 20 are exchanged with each other in the state where the medium bobbin and small bobbin are kept hung therefrom, and as a result, the bobbin arrangement shown in Fig. 3 is produced and, the roving exchange operation including the roving-piecing operation is conducted again. The roving

exchange is accomplished by dismounting the bobbin hangers 19 and 20 from the rails 11 and 12 and turning them by 180° . This construction is disclosed in detail in Japanese Examined Patent Publication No. 60-14848 granted to the applicant of the instant application equivalent to EP-A-124,662, but since the present invention is not limited to any particular roving exchange method, detailed explanation is omitted. Supply of the full bobbin to the spare bobbin hanger 24 is accomplished by fitting the full bobbin to the carriage bar 17 at the position in the roving frame and moving the full bobbin together with the carriage bar 17 to a predetermined position on the spare rail 15.

As pointed out hereinbefore, the roving exchanger 50 can be moved along the front face of the machine stand of the spinning frame, that is, along the row of the spindles 25. As shown in Figs. 1 through 3, below a body 51 of the roving exchanger 50, there are arranged wheels 51a, guide rollers 29 on the side faces of the body 51 confronting the spinning frame, a running motor 21 in the body 21, and a scroll cam 22 co-operating with the running motor 21. A guide rail 28 is attached to a spindle rail 26 of the spinning frame through an attachment bracket 27, and many guide pins 30 are planted on the outer surface of the guide rail 28 at the same intervals as the pitch intervals of the front bobbin hanger 19. The guide roller 29 is rotatable on the guide rail 28, and therefore, by rotating the scroll cam 22 in the state where a guide pin 30 is engaged with the scroll cam 22, the roving exchanger 50 can be moved along the row of spindles of the spinning frame and can be stopped at a predetermined position.

The construction of the roving exchanger 50 will now be described. The roving exchanger 50 comprises mechanisms for performing roving piecing and roving exchange in a predetermined order and mechanisms for driving these mechanisms. More specifically, in the roving exchanger 50 shown in Fig. 1 where small bobbins 1c on six front bobbin hangers 19 are exchanged at one time with full bobbins 1a on six spare bobbin hangers 24, there are arranged one full bobbin exchange head 52 located at the center, moved vertically by a lift mechanism 31 and moved forward and backward, which supports six pegs, small bobbin exchange heads 55 located on both sides of the lift mechanism 31 for the full bobbin exchange head, moved vertically by lift mechanisms 41a and 41b and moved forward and backward, each of which rotatably supports three pegs, six end take-out nozzles 62 connected to a blower 23 contained in the body 51 of the roving exchanger through hoses 23a to take out the roving ends of the full bobbins by the sucking action of the blower 23, six roving-piecing heads 60 for piling the roving ends of the

full bobbins on the rovings of the small bobbins being spun out, roving hanging plates 58 for hanging the rovings of the full bobbins on the roving guide 2, and driving means for moving the respective members at predetermined cycles. The respective structural elements will now be described with reference to Figs. 1 through 20.

The full bobbin exchange head 52 is first described. Six full bobbin exchange pegs 53 are rotatably arranged on a change bar 71 of the full bobbin exchange head 52 (see Fig. 11). The pegs 53 should be moved vertically and also moved forward and backward for moving the full bobbins 1a at the positions shown in Fig. 3 to the positions of the small bobbins 1c by using the pegs 53. As shown in Fig. 5, the change bar 71 on which the six pegs 53 are arranged is disposed above the lift body 37 of the full bobbin exchange head lift mechanism 31 shown in Fig. 1 through a link mechanism comprising an inner link 75 and an outer link 76 as the main parts. Two chains 36a and 36b parallel to each other in the vertical direction are connected to the lift body 37, and the lift body 37 is moved vertically by vertically moving the chains 36a and 36b by the motor 32 for the full bobbin exchange head lift mechanism arranged in the roving exchanger 50. More specifically, a chain wheel 33a is attached to a shaft 33 of the motor 32 and the rotation of the chain wheel 33a is transmitted to a shaft 34 rotatably supported on the body 51 of the roving exchanger 50 through a chain 33b and a chain wheel 34a. Chain wheels 35a and 35b are attached to both ends of the shaft 34, and one ends of the chains 36a and 36b hung on the chain wheels 35a and 35b are directly connected to the lower portion of the lift body 37 while the other ends of the chains 36a and 36b are connected to the upper portion of the lift body 37 through chain wheels 39a and 39b rotatably arranged in the upper portion of the body 51. Accordingly, the vertical movement of the lift body 37 is attained by the rotation of the shaft 34. Since the lift body 37 is slidably fitted in guide members 38a and 38b arranged vertically on the body 51, accurate movement of the lift body 37 in the vertical direction is assured and maintained. The forward and backward movement of the full bobbin exchange head 52 is performed by a forward and backward movement mechanism for the full bobbin exchange head shown in Fig. 5. A housing 77 is arranged above the lift body 37, and the rotation of a motor 86 within the housing 77 swings an arm 82 through a reduction gear 85 and gears 84 and 83, and this swinging movement is transmitted to a swinging arm 80 through a swinging pin 81 mounted on the top end of the arm 82 and a long hole 80a of a swinging arm 80, with which the sliding pin 81 is engaged. The lower end of the outer link 76 and

the swinging arm 80 are secured to a pin 79 pivoted on the housing 77. Accordingly, the reciprocative rotary movement of a drive gear 84 in the direction of the arrow results in the swinging movement of the swinging arm 80 and outer link 76 in the direction of the arrow. One end of a change bar supporting member 72 is connected to the top end of the outer link 76 through a pivot pin 74, and the change bar 71 is secured to the other end of the supporting member 72. A pivot pin 73 is arranged in the intermediate portion of the change bar supporting member 72, and the top end of the inner link 75 is connected to the change bar supporting member 72 through this pivot pin 73. The lower end of the inner link 75 is connected to the housing 77 through a pivot pin 78. Accordingly, by the swinging movement of the outer link 76 in the direction of the arrow, the pegs 53 on the change bar 71 are moved forward and backward to and from the spinning frame while maintaining the vertical posture, and they can be moved to the position just below the spare bobbin hanger 24 and to the position just below the front bobbin hanger 19.

Full bobbin pegs 53 and the rotation mechanism for these pegs 53 in the full bobbin exchange head 52 will now be described with reference to Figs. 10 through 13. As shown in Fig. 1 and Fig. 11, six pegs 53 (53a, 53b, 53c, 53d, 53e and 53f) are arranged at a pitch interval of 2 spindles in the change bar 71 of the full bobbin exchange head 52. As described in detail hereinafter with reference to the roving exchange operation, these pegs 53 are rotated for rewinding rovings from full bobbins and winding rovings thereon at the respective steps of the roving exchange operation. At the start of the roving exchange operation, as shown in Fig. 10, alternate pegs 53 are independently rotated by 180° to the other pegs 53. This is because the ends of the rovings on full bobbins are smoothly taken out in the present embodiment, as described below. In the roving frame, the phase of the position of the presser of the flyer in the front row is different by 180° from the phase of the position of the presser of the flyer in the rear row, and the ends of rovings on full bobbins in the front row are arranged on the opposite side to the ends of rovings on full bobbins in the rear row, that is, apart by 180° from the ends of rovings in the rear row. Accordingly, full bobbins of the front and rear rows doffed in the roving frame are alternately picked up and arranged in a line, and if full bobbins arranged in one line are suspended from the spare rail 15 by using the bobbin carriage 17, as shown in Fig. 10-(A), the ends lae of the rovings 1a of these full bobbins are located at positions opposite by 180° to each other. More specifically, in Fig. 10-(A), if the ends lae of the rovings of the full bobbins located at (a), (c), and (e) confront the take-out

nozzles 62, the ends lae of the rovings of the full bobbins located at (b), (d), and (f) are present on the side opposite to the take-out nozzles 62. If in this state all of the six full bobbins are simultaneously return-rotated for effecting the end take-out operation by the end take-out nozzles 62, since the space between adjacent full bobbins is narrow, although the ends of the rovings located on the side opposite to the end take-out nozzle 62 reach the end take-out nozzles 62, these roving ends adhere to the peripheries of the full bobbins and are wound thereon, and the end take-out operation is often impossible. Accordingly, at first, the full bobbins 1a located at the positions (b), (d), and (f) are rotated by 180° in the winding direction, and as shown in Fig. 10-(B), the roving ends lae of the six full bobbins are arranged to confront the end take-out nozzles 62, and then the six full bobbins are rotated in the rewinding direction. Note, if the space between two adjacent full bobbins is large, the full bobbins may be simultaneously rotated in the rewinding direction directly without once rotating them in the winding direction. In order to rotate the six full bobbins in the above-mentioned alternate manner, as shown in Figs. 11 and 12, the respective pegs 53 are rotatably supported on the change bar 71, and three pegs 53a, 53c, and 53e of these pegs 53 are made rotatable by a belt 163 through pulleys 162a, 162c, and 162e disposed below the pegs 53a, 53c, and 53e, while the other three pegs 53b, 53d, and 53f are similarly made rotatable by a belt 164 through pulleys 162b, 162d, and 162f. Motors 57 and 54 are attached to the change bar 71 to drive the belts 163 and 164 through drive pulleys 57a and 54a. Note, reference numerals 161a through 161i represent guide pulleys for guiding the belts 163 and 164. As shown in Fig. 10, for rotating alternate full bobbins 1a located at the positions (b), (d), and (f) by 180° in the winding direction (clockwise), the motor 54 is rotated counterclockwise in Fig. 11, and for rotating all the full bobbins 1a in the rewinding direction (counterclockwise), the motors 54 and 57 are simultaneously rotated clockwise in Fig. 11.

As shown in Fig. 13 (corresponding to the pegs 53a, 53c, and 53e shown in Fig. 12), the pegs 53 for the full bobbins are rotatably supported on a supporting shaft 166 by bearings attached to the change bar 71, and a fitting portion 166a that can be fitted in a lower hole of the bobbin is formed on the top end of the supporting shaft 166 and a cylindrical bobbin receiver 167 having a flange-like receiving part 167a is vertically movably fitted in the intermediate portion of the supporting shaft 166. The bobbin receiver 167 is urged upward by a spring 167 interposed between the bobbin receiver 167 and a spring receiving plate 168 attached to the base of the supporting shaft 166 to abut against

the fitting portion 166a. The receiving part 167a of the bobbin receiver 167 is formed to have a diameter larger than the diameter of the lower hole of the bobbin, so that the bobbin can be supported.

The periphery of the cylindrical portion of the bobbin receiver 167 is formed to have an outer diameter equal to or smaller than the diameter of the fitting portion 166a, so that the cylindrical portion of the bobbin receiver 167 can be fitted in the lower hole of the bobbin.

The small bobbin exchange head 55 will now be described. Note the small bobbin exchange head 55 should be constructed so that the head 55 can be moved in the vertical direction and forward and backward with respect to the spinning frame. The mechanism for this movement is substantially the same as the movement mechanism for the full bobbin exchange head. As the mechanism for the vertical movement, as shown in Fig. 1, small bobbin exchange head lift mechanisms 41a and 41b are arranged on both sides of the full bobbin exchange head lift mechanism 31 to impart vertical movements to three small bobbin pegs 56, respectively. Two chains 46a and 46b and two chains 46c and 46d extending vertically in parallel to each other are connected to lift bodies 47a and 47b of the lift mechanisms 41a and 41b, respectively. By moving these chains 46a, 46b, 46c, and 46d in the vertical direction by using the motor 42 for the small bobbin exchange head lift mechanism arranged within the body 51 of the roving exchanger 50, the lift bodies 47a and 47b are moved upward and downward. The movement of the chains 46a, 46b, 46c, and 46d will now be described with reference to the chain 46a as an example. The rotation of the motor 42 is transmitted to a common shaft 44 through chain wheels 43a and 43b fixed to the output shaft of the motor 42 and a chain wheel 44a fixed to the common shaft 44, and the rotation of the common shaft 44 is transmitted to the chain 46a through a chain wheel 45a, whereby the chain 46a is moved. The forward-backward movement of the small bobbin exchange head 55 is performed by a mechanism similar to the forward-backward movement mechanism for the full bobbin exchange head 52 described hereinbefore with reference to Fig. 5, so that the pegs 56 can be moved between the stand-by position shown in Fig. 3 and the position just below the spare bobbin hanger 24 or the position just below the front bobbin hanger 19.

The structure of the pegs 56 in the small bobbin exchange head 55 is the same as the structure of the pegs 53 for full bobbins shown in Fig. 13. The mechanism for rotating the respective pegs 56 is quite similar to the mechanism for rotating the full bobbin pegs 53, shown in Figs. 11 and 12. It is sufficient if the three pegs 56 of the small bobbin exchange head 55 are always rotated

in the same direction. Accordingly, it is sufficient if one belt for driving the pegs 56 and one motor for the belt are arranged for each of the left and right small bobbin exchange heads 55.

The end take-out nozzle operating mechanism, the roving-piecing head operating mechanism, and the roving hanging plate operating mechanism will now be described. In the roving exchange mechanism shown in Fig. 1, since the foregoing operating mechanisms are driven by a pair of left and right mechanisms 65 for operating the end take-out nozzles, roving-piecing heads and roving hanging plates, each comprising three operating cams arranged on one shaft, this operating mechanism 65 is first described with reference to Fig. 6. A roving-piecing cam 66, an end take-out cam 67, and a roving hanging cam 68 are fixed to one rotatable cam shaft 93, as shown in Fig. 6. Cam followers 94 corresponding to the cams 66, 67, and 68 and cam levers 95 for indicating the cam followers 94 are arranged. One end of the cam levers 95 are pivoted on the body 51 of the roving exchanger 50 through pins 96, and operating rods 97, 98, and 99 are rotatably connected to the other ends of the cam levers 95. In Fig. 6, only one cam follower 94 and one cam lever 95 are shown, but cam followers and cam levers are disposed for the operating cams 66, 67, and 68, respectively, so that the roving-piecing head operating rod 97, the end take-out nozzle operating rod 98, and the roving hanging plate operating rod 99 can be elongated upward or downward. The rotation of a pair of left and right cam shafts 93 can be accomplished by transmitted the rotation of a motor 87 arranged within the body 51 of the roving exchanger 50 to a chain wheel 90 through a reduction gear 88, a chain wheel 89, and a chain 91 and transmitting the rotation of the chain wheel 90 to the left and right cam shafts 93 through a long intermediate shaft 90a and engaged gears 92a, 92b, and 92c (the gears on the right side are omitted in Fig. 1).

The end take-out nozzle 62 and the end take-out nozzle operating mechanism will now be described with reference to Fig. 7. A pair of left and right end take-out nozzle operating mechanisms are arranged symmetrically with each other. In Fig. 1, only the right mechanism is shown and the left mechanism is omitted. The end take-out nozzle 62 is fixedly connected to an end take-out nozzle supporting pipe 139 through a nozzle attachment bracket 138 arranged on the lower end of the nozzle 62, and the roving end of the full bobbin 1a is taken out from the top end of the end take-out nozzle 62 by sucking air currents reaching both ends of the end take-out nozzle supporting pipe 139 from a blower 23 through a hose 23a. The top end of the end take-out nozzle 62 is moved along a locus 140 shown in Fig. 7 so that the roving taken

out is guided to the roving-piecing head 60.

In the roving exchanger 50 shown in Fig. 1, six end take-out nozzles 62 are secured to the supporting pipe 139 at intervals of two spindles. The movement of the end take-out nozzle operating rod 98 by the end take-out operation cam 67 of the operating mechanism 65 illustrated in Fig. 6 imparts a swinging movement, with a pin 122 as the center, to a sector gear 121 through a pin 123, and this swinging movement gives a swinging movement, with a pin 126 as the center, to a lift arm 127 through a gear 124 and a sector gear 125. A parallel guide 132 having two linear rods 133 is arranged on the body 51 of the roving exchanger 50, and a long hole 129 is formed in an upper portion 128a of a slider 128 and a slide pin 131 mounted on the top end of the lift arm 127 is slidably fitted in this long hole 129, so that if the lift arm 127 is swung in the direction of the arrow, the slider 128 is vertically moved along the parallel guide 132. The right end of the lower portion 128b of the slider 128 rotatably supports one end of the end take-out nozzle supporting pipe 139. A guide plate 134 having a curved guide hole 135 defining the locus of the top end of the end take-out nozzle 62 is arranged on the body 51 of the roving exchanger 50, and a slide pin 136 engaged with the curved guide hole 135 is mounted on one end of a connecting arm 137 and the other end of the connecting arm 137 is integrally connected to the end take-out nozzle supporting pipe 139. Accordingly, when the slider 128 rises, the end take-out nozzle 62 itself rises, and simultaneously, the slide pin 136 is guided along the curved guide hole 135 to rotate the end take-out nozzle 62, with the pipe 139 as the center, and move the top end of the end take-out nozzle 62 along the locus 140. Preferably, that a comb effective for cutting the roving is formed in the interior of the top end of the end take-out nozzle 62, as disclosed in Japanese Examined Patent Publication No. 57-51649.

The roving-piecing head 60 and the roving-piecing head operating mechanism will now be described with reference to Fig. 8. A pair of left and right roving-piecing head operating mechanisms are disposed. The roving-piecing head 60 is a device for piling the roving end taken out from the full bobbin by the end take-out nozzle 62 on the roving of the small bobbin while spinning and cutting the roving of the small bobbin. In the roving exchanger 50 shown in Fig. 1, six roving-piecing heads 60 corresponding to the above-mentioned end take-out nozzles 62 are arranged on a roving-piecing head supporting bar 148 (see Fig. 17). When the end take-out nozzle 62 sucks the roving end, as shown in Fig. 8, the roving-piecing head 60 is faced downward in the vertical direction from the roving-piecing head supporting bar 148 to avoid

interference by the end take-out nozzle 62. To hold the roving end and pile the roving end on the roving of the small bobbin during spinning, the roving-piecing head 60 should be turned counterclockwise or moved to the right in Fig. 8. The roving-piecing head operating mechanism for imparting such a movement to the roving-piecing head 60 is a mechanism for transmitting the downward movement of the roving-piecing head operating rod 97 by the roving-piecing cam 66 of the operating mechanism 65 shown in Fig. 6 to an inner link 146 and an outer link 147, with a time difference, through a swinging arm 141 and turning them clockwise. The inner link 146 and outer link 147 are rotatably supported on the body 51 of the roving exchanger 50 through a pivoting shaft 145, and the inner link 146 and outer link 147 are stretched in the counterclockwise direction by stretching springs 152 and 153, and the inner link 146 is received by a stopper 51h. The pivoting shaft 145 is supported rotatably and slightly movably in the longitudinal direction (in the left-right direction in Fig. 1) by a pair of left and right supporting members 51e secured to the body 51, and the lower end of the inner link 146 is freely fitted on the pivoting shaft 145, and the lower end of the outer link 147 is secured to the pivoting shaft 145. A sector gear 144 is secured to the end portion of the pivoting shaft 145 and this sector gear 144 is engaged with a gear 141a integrated with the swinging arm 141. A pin 151 is mounted on the upper end of the outer link 147 and is engaged with a long hole 150a of a connecting link 150.

The top end of the inner link 146 rotatably supports a pin 149 planted integrally on the end face of a roving-piecing head supporting bar 148, and the upper end of the connecting link 150 is secured to the pin 149, so that the roving-piecing head supporting bar 148 can be turned, with the pin 149 as the center, by the swinging movement of the connecting link 150.

Accordingly, by the downward movement of the roving-piecing head operating rod 97, the swinging arm 141 is turned counterclockwise, with the pin 143 as the center, and the outer link 147 is swung clockwise against the stretching force of the spring 153 through the sector gear 144 and pivoting shaft 145 to press the pin 151 on the top end of the outer link 147 to the right and turn the connecting pin 150 counterclockwise, with the pin 149 as the center. Accordingly, the roving-piecing head supporting bar 148 is turned counterclockwise together with the roving-piecing head 60. This turning movement continues from the position of the connecting link 150 shown in Fig. 8 to the opposite position symmetric with respect to the vertical line passing through the pin 149, so that the roving-

piecing head 60 is substantially at the horizontal posture. When the roving-piecing head operating rod 97 is moved downward and the outer link 147 is further turned clockwise, the pin 151 abuts against the lower end of the long hole 150a, and then the pin 149 is drawn to the right by the connecting link 150 and the inner link 146 is turned with the shaft 145 as the center. Accordingly, the roving-piecing head 60 disposed in the horizontal direction is advanced to the roving R from the small bobbin 1c during spinning along the locus 154.

In the spinning frame, the arrangement position of the full bobbin is deviated from the position of the draft zone 5 by 1/2 spindle pitch, as shown in Fig. 4. Therefore, when the end of the roving of the full bobbin is taken out and this roving is held on the roving-piecing head 60 and moved to the draft zone 5, the roving-piecing head 60 should be laterally moved by 1/2 spindle pitch toward the draft zone 5 in which the roving of the small bobbin is introduced. For effecting this lateral movement, a roving-piecing head lateral movement mechanism 61 is disposed to move the pivoting shaft 145. This roving-piecing head lateral movement mechanism 61 has a reduction gear-provided motor 217 secured to the body 51, a worm 218 to be rotated by this motor 217, and an arm 155 having a worm wheel to be engaged with the worm 218 and being swung with a pin 155a as the center. By the swinging movement of the arm 155, the rod 145 is moved selectively to the right or the left in Fig. 1.

The structure and operation of the roving-piecing head 60 will now be described with reference to Figs. 14 through 19. Figure 14 is a plan view showing an example of the roving-piecing head, and Fig. 15 is a side view thereof. The roving-piecing head 60 shown in Figs. 14 and 15 comprises a roving-piecing head body 171 having a roving guide groove 173 formed on the top end portion thereof and a roving holding lever 174 capable of reciprocating across the roving guide groove 173 in the plane parallel to the upper surface of the body 171. The body 171 is secured to a roving-piecing head supporting bar 148 having a \sqcap -shaped section. The roving holding lever 174 is rotatably supported near the center thereof by a pivot pin 178 secured to the body 171. As shown in Fig. 15, a roving holding lever operating bar 182 is slidably arranged on the roving-piecing head supporting bar 148, and an operating member 181 having on the top end thereof an opening for containing a pin 179 therein is secured to the operating lever 182. Nip pieces 176 and 177 having roving holding faces 176a and 177a confronting both roving holding side faces 175a and 175b of a roving holding portion 175 on the top end of the roving holding lever 174 are secured to the upper

surface of the body 171 on both sides of the roving guide grooves 173. A triangular roving guide opening 172 is formed on the top end of the body 171 to guide the roving to the roving guide groove 173, and the opening of a nozzle 183 for jetting air fed through a conduit 184 to the inner portion of the roving guide groove 173 downward is formed on one side face of the roving guide opening 172.

An air stream jetted from this nozzle 183 serves to straighten the curved or bent end of the roving of the full bobbin piled on the roving of the small bobbin during spinning. Figure 14-(A) shows the position of the roving holding lever 174 where the operating lever 182 is moved to the right and the roving (not shown) of the small bobbin is held between the roving holding face 175a of the roving holding lever 174 and the roving holding face 177a of the nip piece 177, and the position of the roving holding lever 174 in the stand-by state for guiding the roving of the full bobbin to the roving guide groove 173. Where the roving-piecing head 60 is located at the vertical posture described hereinbefore with reference to Fig. 8, the roving extending between the full bobbin 1c and the end take-out nozzle 62 is guided into the roving guide groove 173 through the roving guide opening 172, and if the roving holding lever 174 turns the roving holding portion 174 to the right as shown in Fig. 14-(C), the roving is held by the roving holding lever 174 and the nip piece 176. Then, while the roving-piecing head 60 is moved from the vertical position to the horizontal position, the roving extending from the end take-out nozzle 62 is cut in a brush tip-like shape downstream of the holding point of the roving holding lever 174. As the result, the brush tip-like roving end to be piled on the roving of the small bobbin during spinning is formed in the roving guide groove 173. If this movement from the vertical position to the horizontal position is repeated, single filaments entangled at the end of the roving are removed and the brush tip-like shape becomes uniform. In this state, the roving-piecing head 60 is brought close to the roving R of the small bobbin during spinning along the locus indicated by a solid line 154 in Fig. 8 and simultaneously, the roving-piecing head 60 is laterally moved to the right or the left in Fig. 1 by 1/2 spindle pitch by the roving-piecing head lateral movement mechanism 61, whereby the roving R of the small bobbin during spinning is guided into the roving guide groove 173 and the end of the roving of the full bobbin is piled on the roving R of the small bobbin. Then, as shown in Fig. 14-(B), the roving holding portion 175 of the roving holding lever 174 is turned to the left and moved to the neutral position, whereby the end of the roving of the full bobbin is introduced into the trumpet 6 in the state piled on the roving R of the small bobbin

while being guided by the roving R. Then, at the point when the roving end of the full bobbin is guided into the back roller 5a of the draft zone 5, as shown in Fig. 14-(A), the roving holding portion 175 is turned to the left to the utmost, and the roving R of the small bobbin is held between the left holding face 175a of the roving holding portion 175 of the roving holding lever 174 and the holding face 177a of the left nip piece 177. Since the roving on the downstream side of the roving-piecing head is inserted toward the draft zone 5, the pieced portion of the roving is travelled downward and since the roving R located upstream of the pieced portion is held by the roving holding lever 174 and the left nip piece 177, the roving R is pulled and cut to complete the roving-piecing operation. Then, the roving holding lever 174 is turned to the neutral position and the roving R is released from holding.

The sliding movement of an operating bar 182 for the turning movement of the roving holding lever 174 will now be described with reference to Fig. 19. As shown in Fig. 19, operating members 182 for six roving-piecing heads 60 are secured to the operating bar 182 contained in the roving-piecing head supporting bar 148. Plungers of four operating bar sliding solenoids 185 secured to the roving-piecing head supporting bar 148 are connected to the operating bar 182 through L-shaped members 188, pins 200 and holes 186. When each solenoid 185 is not energized, the corresponding plunger 189 is allowed to freely move, and when the solenoid 185 is energized, the plunger 189 is caused to sink. The pin 200 is engaged with the operating bar 182 through the hole 186 to transmit the movement of the plunger 189 to the operating bar 182. The shapes of the holes 186 with which the pins 200 are engaged are such that the holes 186a and 186b corresponding to the solenoids 185a and 185d are long holes elongated in the direction of the movement of the operating bar 182, and the holes 186b and 186c corresponding to the solenoids 185b and 185c are long holes elongated in the direction orthogonal to the direction of the movement of the operating bar 182. As shown in Fig. 19-(A), when the solenoid 185c is energized, the plunger 189 is attracted to the solenoid 185c and the pin 200c is moved to the right as indicated by arrow C to move the operating bar 182 to the right as indicated by arrow XI, whereby the top end 175 of the roving holding lever 174 is turned to the left and abuts against the nip piece 176 to hold the roving of the full bobbin [see Fig. 14-(C)]. Then, in order to shift the roving holding lever 174 to the neutral position shown in Fig. 14-(B), as shown in Fig. 19-(B), the solenoid 185d is energized to move the pin 200d in the direction indicated by arrow D, whereby the operating bar 182 is moved in the direction in-

licated by arrow X2. Simultaneously, the solenoid 185a is energized to keep the plunger 189 of the solenoid 185a in the attracted and sunk state. Accordingly, the pin 200a abuts to the right end of the long hole 186a and the operating bar 182 is set at the neutral position.

In order to move the roving holding lever 174 to the position shown in Fig. 14-(A) for holding the roving of the small bobbin during spinning, as shown in Fig. 19-(C), the solenoid 185b is energized to draw back the plunger 189, whereby the pin 200b is moved in the direction indicated by arrow B and the operating bar 182 is moved in the direction indicated by arrow X3.

By repeating the above operation, the reciprocative turning movement of the roving holding lever 174 in the roving-piecing head 60 is attained according to a predetermined plan.

Another example of the roving-piecing head 60 is shown in Fig. 16. As is seen from the side view of Fig. 16-(B), this roving-piecing head 60a is different from the roving-piecing head 60 shown in Fig. 15 in that a lever 174a for the roving of the full bobbin and a lever 174b for the roving R being withdrawn from the small bobbin are used as the roving holding lever. Accordingly, an operating bar 182a for the roving of the full bobbin and an operating bar 182b for the roving R are disposed as the operating bar, and the roving R is cut upstream of the portion to be piled and the end of the roving of the full bobbin is piled on the roving R of the small bobbin, and the roving-piecing operation is performed in the same manner as in the case of the roving-piecing head 60 shown in Figs. 14 and 15.

Still another example of the roving-piecing head 60 is shown in Figs. 17 and 18. This roving-piecing head 60b is characterized in that a roving guide member 201 is arranged below the body 171. A Y-shaped roving guide groove 203 that can communicate with the roving guide groove 173 of the body 171 is formed on the top end portion of the roving guide member 201, and the rear end portion of the roving guide member 201 is swingably pivoted on a projection 171a of the body 171 through a pivoting pin 205. A compression spring 206 is arranged between the portion 201a of the roving guide member 201 in the rear of the pivoting pin 205 and the roving-piecing head supporting bar 148 to urge the roving guide member 201 and cause it to abut against the body 171. As shown in Fig. 17-(A), a cam plate 204 is secured to the side portion of the roving guide member 201 on the side of the guide groove 203. When this roving-piecing head 60b is swung toward the trumpet 6, the cam face (top face) of the cam plate 204 abuts against the supporting rod 7 of the top arm of the spinning frame, and the roving guide member 201 is swung downward and the forward end of the roving-piecing

head 60b, that is, the roving end of the full bobbin, is piled on the roving of the small bobbin. This state is shown in Fig. 18. Where the roving is composed of staple having a long length, the brush tip-like end of the roving often protrudes below the roving guide member 201. In this case, with the downward swing of the roving guide member 201, the protruding end of the roving is contained in the roving guide groove 203 and the roving end of the full bobbin is piled on the roving R of the small bobbin. In each of the roving-piecing heads 60, 60a, and 60b, if the roving end of the full bobbin protrudes below the roving guide groove, the protruding roving end is bent or curved by abutment against the trumpet 6 and is not inserted or is inserted in the state where filaments of the roving are bent or curved, and yarn breakage often occurs. However, if the roving end of the full bobbin is contained in the roving guide groove and is piled on the roving of the small bobbin in this state, the roving-piecing operation can be assured.

In the foregoing embodiment, after the roving-piecing operation, the roving of the small bobbin during spinning is cut by holding the roving between the roving holding lever 174 and the nip piece 177 and pulling and cutting the roving by the back roller 5a. However, within the scope of the present invention, there may be adopted a method in which sliding contact is produced between the lower face of the roving holding lever 174 and the top face of the nip piece 177 in the above-mentioned embodiment and the roving is cut by the lower face of the roving holding lever 174 and the top face of the nip piece 177 like scissors. Furthermore, the reciprocating movement of the roving holding lever 174 across the roving guide groove 173 may be accomplished by parallel movement caused by fixing the roving holding lever 174 to the operating bar 182. Where roving holding levers 174 of a plurality of roving-piecing heads 60 are operated by one operating bar 182, in each roving-piecing head 60, in order to properly hold the roving, it is preferably a spring is interposed between the roving holding lever 174 and the operating bar 182.

The roving hanging plate operating mechanism will now be described with reference to Fig. 9. A pair of left and right roving hanging plate operating mechanisms are symmetrically disposed. The roving hanging plate 58 is a plate for hanging the roving of the full bobbin, in which piecing is completed, on the roving guide 2. For this purpose, the roving hanging plate 58 should be moved along the locus 116 shown in Fig. 9. In the roving exchanger 50 shown in Fig. 1, the roving hanging plate 58 is formed as one plate extending in the longitudinal direction of the roving exchanger 50. According to the roving hanging plate operating mechanism, the

downward movement of the roving hanging plate operating rod 95 by the roving hanging cam 68 of the operating mechanism 65 is converted to the movement of the roving hanging plate along an intended locus through the link mechanism comprising inner and outer links 101 and 102 in combination. More specifically, a sector gear 104 is pivoted on the body 51 through a pin 109, and by the downward movement of the roving hanging plate operating rod 95, the sector gear 104 is turned clockwise, with the pin 109 as the center, resulting in a counterclockwise turning of a sector gear 105. This sector gear 105 is fixed to a shaft 112 rotatably and slidably supported in the longitudinal direction by a supporting member 103 attached to the body 51, and the top end of the inner link 101 is secured to the shaft 112. The lower end of the inner link 101 is rotatably pivoted on a pin 114a planted in a connecting ring 107 and a pin 115 planted in the rear end of a supporting bar 108. A shaft 117 is supported on the supporting member 103 rotatably and movably in the axial direction, and one end of the connecting link 106 is rotatably fixed to the shaft 117 and the other end of the connecting link 106 is rotatably fixed to the shaft 112, so that the movement of the shaft 112 in the axial direction is transmitted to the shaft 117. The top end of the outer link 102 is fixed to the shaft 117 and the lower end of the outer link 102 is connected to the connecting pin 107 through a pin 113. A small gear 114 is wedged to the pin 114a planted in the connecting link 107 and a small gear 115 is wedged to the pin 115a planted in the supporting lever 108, so that the small gears 114 and 115 are engaged with each other. The roving hanging plate 58 is hung on and fixed to the top ends of both the supporting levers 108 (see Fig. 1). Six V-shaped guiding notches are arranged on the top end side of the roving hanging plate to regulate the position of the roving in the left-right direction when the roving of the full bobbin, in which piecing is completed, is guided to the roving guide 2, though these notches are not shown in the drawings. In this construction, with the counterclockwise turning of the sector gear 105, both of the inner and outer links 101 and 102 are turned counterclockwise, and when the inner link 101 is brought close to the swinging end thereof, because of the relationship among the connecting lengths of the inner and outer links 101 and 102 and the connecting link 107, the connecting link 107 is turned counterclockwise with the pin 114a as the fulcrum. By this counterclockwise turning of the connecting pin 107, the small gear 115 engaged with the small gear 114 is turned clockwise. Accordingly, the top end of the roving hanging plate 58 is moved along the locus 116 shown in Fig. 9, and when the top end of the roving hanging plate 58 reaches the swinging end of the inner link 101, the roving hanging plate 58 is

inclined toward the machine stand above the roving guide 2 to guide the roving of the full bobbin into the roving guide 2.

The mechanism for the lateral movement of the roving hanging plate 58 will now be described. The roving hanging plate 58 is moved, for example, by 20 mm, to hang the roving of the full bobbin on the nail 2b of the roving guide 2 shown in Fig. 20, and this movement is accomplished by the mechanism 59 for the lateral movement of the roving hanging plate shown in Fig. 1. The mechanism 59 for the lateral movement of the roving hanging plate comprises a reduction gear-provided motor 117 secured to the body 51, a worm 118 rotated through a gear 117a by the motor 117 and an arm 119 having on one end thereof a worm wheel engaged with the worm 118, which is selectively swung to the right or the left in Fig. 1, with a pin 119a as the center, to laterally move a shaft of the roving hanging plate operating mechanism. As shown in Fig. 9, by the lateral movement of the shaft 112, the outer link 102 is simultaneously laterally moved through the inner link 101 and connecting link 106, whereby the roving hanging plate 58 having the roving of the full bobbin held thereon is also laterally moved. This lateral movement of the roving hanging plate is performed in the state where the roving hanging plate 58 is elevated and the roving is guided in the roving guide 2. As the result, the roving is hung on the nail 2b of the roving guide 2.

As described hereinbefore, various operating mechanisms, each having a motor, are arranged in the roving exchanger. As is apparent from the description of the operation of the roving exchanger given hereinafter, movements of the end take-out nozzle, roving-piecing head, roving hanging plate, full bobbin exchange head, and small bobbin exchange head are performed in a predetermined order. Accordingly, the motors of the above-mentioned various operating mechanisms are operated in a predetermined order based on instructions from a controller 300 arranged in the body 51 of the roving exchanger 50, whereby exchange between the full bobbin and the small bobbin is performed and the roving of the full bobbin is pieced with the roving of the small bobbin during spinning. The construction and function of the controller are well-known. Accordingly, a detailed description of the controller is omitted.

The roving exchange operation in a broad sense, that is, roving exchange and roving piecing between the full bobbin and the small bobbin, which is performed by using the roving exchanger 50 having the above-mentioned structure will now be described. At first, as shown in Fig. 3, when with the advance of the spinning operation, the bobbin suspended from the front bobbin hanger 19 of the creel of the spinning frame becomes a small

bobbin 1c and the bobbin suspended from the rear bobbin hanger 20 becomes a medium bobbin 1b, the guide roller 29 of the roving exchanger 50 is placed on the guide rail 28 and the roving exchanger 50 is brought close to the spinning frame. By this time, a full bobbin 1a has been suspended on the spare bobbin hanger 24 arranged at the position confronting the front bobbin hanger 19 of the spinning frame on the spare rail 15 of the spinning frame. Note, when the bobbin suspended from the rear bobbin hanger 20 becomes small and roving exchange becomes necessary, the small bobbin is arranged in the front row in advance by using the above-mentioned roving exchanger 50.

The roving exchanger 50 is travelled along the front face of the spinning frame by driving the scroll cam 22 by the driving motor 21, and is stopped at the position where six small bobbins 1c are located at the set positions. At this position, a series of roving exchange and roving-piecing operations are carried out in sequence. These operations will now be described with reference to Fig. 21.

The amount of the roving left on the small bobbin 1c is small and roving exchange is necessary [Fig. 21-(1)]. In this state, as shown in Fig. 21-(2), the full bobbin exchange head 52 located below the full bobbin 1a suspended from the bobbin hanger 24 of the spare rail 15 is elevated by the lift mechanism 31, and the peg 53 of the full bobbin exchange head 52 is fitted with the lower portion of the full bobbin 1a and the full bobbin 1a is taken out from the bobbin hanger 24. The full bobbin exchange head 52 having the full bobbin 1a placed thereon is brought down and returned to the original position shown in Fig. 21-(1). Synchronously with the falling movement of the full bobbin exchange head 52, the end take-out nozzle 62 is elevated by the end take-out nozzle operating mechanism, and the end take-out nozzle 62 is stopped at the position where the sucking opening of the end take-out nozzle 62 is located at the position corresponding to the height of the roving end of the dropped full bobbin 1a [Fig. 21-(3)]. Then, the motor 54 of the peg rotating mechanism contained in the full bobbin exchange head 52 is rotated counterclockwise, when seen from above, and alternate full bobbins having the roving end on the side opposite to the end take-out nozzle 62 are rotated by 180° in the winding direction to move the roving ends of these full bobbins toward the end take-out nozzle 62. Then, the motors 54 and 57 are rotated clockwise to rotate the six full bobbins in the rewinding direction, and the sucking force of the blower 23 acts on the end take-out nozzle 62. The suction opening of the end take-out nozzle 62 sucks the roving end of the corresponding full bobbin 1a to take out the roving end of the full bobbin 1a [Fig. 21-(4)]. While

the rotation of the full bobbin and suction by the end take-out nozzle 62 are continued, the end take-out nozzle 62 is brought down and returned to the original position, and the taken-out roving is inserted into the roving guide groove 173 of the roving-piecing head 60 [Fig. 21-(5)]. The solenoid 185c of the roving-piecing head 60 is energized to actuate the roving holding lever 174 to hold the roving of the full bobbin between the roving holding portion 175 and the nip piece 176. Simultaneously, the roving-piecing head, which has been kept at the downwardly vertical posture, is set at the substantially horizontal posture by the roving-piecing head operating mechanism. At this point, the roving of the full bobbin 1a is caught by the comb attached to the interior of the top end of the end take-out nozzle 62 and is cut between the holding point in the roving-piecing head 60 and the end take-out nozzle 62 to form a roving end [Fig. 21-(6)]. The roving-piecing head 60 holding the roving of the full bobbin having the formed roving end is advanced toward the draft zone 5 of the spinning frame by the roving-piecing head operating mechanism. The advance of the roving-piecing head 60 is once stopped and the roving-piecing head 60 is laterally moved by 1/2 spindle pitch toward the trumpet 6 in which the roving of the small bobbin is guided (to the right in Fig. 4) by the roving-piecing head lateral movement mechanism 61 and set at a position in the longitudinal direction of the spinning frame, which corresponds to the trumpet 6 located upstream of the draft zone 5 of the spinning frame. Then, the advance is conducted and the roving end of the full bobbin reaches above the trumpet 6. Where the roving-piecing head 60b is used, the state shown in Fig. 18 is brought about. At this point, the roving of the small bobbin during spinning is introduced into the roving guide groove 173 of the roving-piecing head 60 and is piled on the roving of the full bobbin. When the roving-piecing head 60 is advanced, the full bobbin is rotated counterclockwise by the peg rotation mechanism of the full bobbin exchange head 52 to unwind the roving and prevent breakage of the roving by the advance of the roving-piecing head 69. Simultaneously, to maintain slackening of the unwound roving, the roving hanging plate 58 is slightly elevated by the roving hanging plate operating mechanism. After stopping the advance of the roving-piecing head 60, the solenoids 185a and 186b of the roving-piecing head 60 are energized and the roving holding lever 174 is turned to the neutral position to release the holding of the roving of the full bobbin, and the released roving of the full bobbin 1a is guided by the roving of the small bobbin during spinning and inserted into the trumpet 6 together with the roving of the small bobbin. After the roving end of the full bobbin 1a is held by

the back roller 5a of the draft zone 5, the solenoid 185b of the roving-piecing head 60 is energized, the roving holding lever 174 is further turned and the roving of the small bobbin is held between the roving holding portion 175 and the nip piece 177. Since the roving of the small bobbin is held by the roving-piecing head 60, the roving is drafted and cut between the roving-piecing head 60 and the back roller 5a [Fig. 21-(7)]. The full bobbin 1a in which roving piecing has been completed is elevated again close to the spare bobbin hanger 24 by the full bobbin exchange head 52 to an extent such that the full bobbin 1a is not attached to the spare bobbin hanger 24, and is then stopped. At this point, the full bobbin 1a is rotated counterclockwise by the peg rotation mechanism of the full bobbin exchange head 52 to unwind the roving and prevent breakage of the roving by the raising of the full bobbin 1a. Simultaneously, the roving hanging plate 58 is elevated again to the point near the roving guide 2 to hold the slack in the unwound roving of the full bobbin 1a. During this period, the solenoids 185a and 185d of the roving-piecing head 60 are energized to move the roving holding lever 174 to the neutral position, whereby the roving of the small bobbin is released from holding by the roving holding lever 174, and simultaneously, the roving-piecing head is retreated and stopped at the position where the roving of the full bobbin 1a is taken out from the roving-piecing head 60 [Fig. 21-(8)]. The small bobbin exchange head 55 is advanced to the position just below the small bobbin of the front row of the creel by the forward-backward movement mechanism and lift mechanism, and the small bobbin exchange head 55 is elevated to take out the small bobbin 1c from the front bobbin hanger 19 [Fig. 21-(9)]. The small bobbin exchange head 55 having the small bobbin placed thereon is dropped [Fig. 21-(10)] and is retreated and returned to the original position [Fig. 21-(11)]. The small bobbin is rotated clockwise, seen from above, by the peg rotation mechanism contained in the small bobbin exchange head to wind the cut roving. When the small bobbin exchange head 55 is returned to the original position, the full bobbin exchange head 52 is dropped and returned to the original position. At this point, the full bobbin 1a is rotated clockwise in an appropriate quantity by the peg rotation mechanism of the full bobbin exchange head 52 to wind the roving and maintain appropriate slack in the roving produced by dropping the full bobbin exchange head 52. After the roving hanging plate 56 is fully elevated, the roving hanging plate 58 is laterally moved by the roving hanging plate lateral movement mechanism 59 to hang the roving of the full bobbin 1a on the roving guide 2 arranged in the spinning frame. Simultaneously, the roving-piecing head 60 is retreated

and returned to the original position. During the retreating movement, the retreat of the roving-piecing head 60 is stopped, and the roving-piecing head 60 is laterally moved and returned to the position corresponding to the bobbin on the creel with respect to the longitudinal direction of the spinning frame [Fig. 21-(12)]. The roving-piecing head 60 which has completed the retreat is returned to the vertical state from the horizontal state [Fig. 21-(13)]. The full bobbin exchange head 52 is advanced to the position just below the front bobbin hanger 19 and is elevated to attach the full bobbin 1a to the bobbin hanger 19. At this time, the full bobbin 1a is rotated clockwise in an appropriate quantity by the peg rotation mechanism of the full bobbin exchange head 52 to maintain the appropriate slack in the roving produced by advance and retreat of the full bobbin exchange head 52. Then, the small bobbin exchange head 55 is advanced to the point just below the spare bobbin hanger 24 of the spare rail 15 and is elevated to attach the small bobbin to the bobbin hanger 24. The roving hanging plate 58 is dropped, laterally moved to a midway point and returned to the original position [Fig. 21-(14)]. The small bobbin exchange head 55 is dropped, retreated, and returned to the original position [Fig. 21-(15)].

Thus, one cycle of the roving exchange operation is completed, and the roving exchange 50 is laterally moved by a distance corresponding to six bobbins of the front bobbin hanger 19, and is then stopped. Thus, the roving exchange operation is repeated from one end of the spinning frame to the other end.

The roving exchange and roving-piecing operations may be also performed according to the following procedures by the roving exchanger 50. The full bobbin exchange head 52 is elevated to attach the full bobbin 1a to the peg 53 [Fig. 21-(2)] and the small bobbin exchange head 55 is advanced and elevated to take out the small bobbin 1c from the front bobbin hanger and then returned to the original position. Where the positional relationship shown in Fig. 21-(11) is established between the full bobbin 1a and the small bobbin 1c, the roving of the small bobbin 1c is spun out. Then, the full bobbin exchange head 52 is brought down, and after the roving end is taken out from the full bobbin 1a, as described hereinbefore, the roving end is held by the roving-piecing head 60 and is guided above the trumpet to effect roving piecing. After roving-piecing, the full bobbin 1a is suspended on the front bobbin hanger 19, and after the roving suspended from the roving guide 2 is wound, the small bobbin 1c is suspended on the spare bobbin hanger 24 of the spare rail.

Where roving piecing is thus carried out while the small bobbin 1c during spinning is placed on

the peg 56 of the small bobbin exchange head 55, the small bobbin 1c should be rotated counterclockwise to produce an appropriate amount of slack so that the spun roving between the small bobbin 1c and the roving guide 2 does not interfere with the full bobbin 1a located in the front of the small bobbin 1c, and the unwinding rotation of the small bobbin 1c should be continued at a speed corresponding to the quantity of the roving until the roving-piecing operation is terminated. According to this method, however, at the time of the exchange between the full bobbin 1a and the small bobbin 1c after roving piecing in the embodiment shown in Fig. 21, the operation of retreating the full bobbin upward for avoiding interference between both bobbins [the operation of the full bobbin 1a in Figs. 21-(9) through 21-(11)] can be omitted.

In the present embodiment, since the roving-piecing head 60 is arranged so that it confronts the center of the full bobbin 1a, midway in the advancing movement, the roving-piecing head 60 is laterally moved by 1/2 spindle pitch to confront the trumpet 6. This lateral movement by 1/2 spindle pitch is carried out in such a manner that, in one spinning frame, if the roving-piecing head 60 is first moved laterally to the left, at the time of subsequent roving exchange, the roving-piecing head 60 is moved laterally to the right. Namely, by carrying out a leftward lateral movement and rightward lateral movement alternately, the roving-piecing head 60 is guided to the position above the trumpet 6 on the side where the roving is spun out from the small bobbin 1c. If the roving exchanger is designed so that the roving-piecing head 60 and the end take-out nozzle 62 can be laterally moved by one spindle pitch and the end of the roving of the full bobbin 1a can be taken out at the position corresponding to the trumpet 6, the lateral movement of the roving-piecing head 60 midway in the advancing movement need not to be performed. In this case, before the roving end is taken out from the full bobbin 1a, the roving-piecing head 60 and end take-out nozzle 62 are moved to the position confronting the trumpet 6 to which the roving of the small bobbin 1c is inserted. Furthermore, when the end take-out nozzle 62 is arranged at the position confronting the trumpet 6 and the roving-piecing head 60 is located so that it can be moved by one spindle pitch, the lateral movement of the roving-piecing head midway in the advancing movement and no lateral movement of the roving-piecing head 60 are effected alternately. When the sucking air stream of the end take-out nozzle 62 is an air current turning in the reverse direction to the twisting direction of the roving, the roving end sucked in the end take-out nozzle 62 from the full bobbin 1a is untwisted and the roving is separated into filaments.

In the foregoing embodiment, after roving piecing, the roving of the small bobbin during spinning is cut by holding the roving between the roving holding lever 174 and the nip piece 177 and stretching and breaking the roving by the back roller 5a. However, even if sliding contact is produced between the lower face of the roving holding lever 174 and the upper face of the nip piece 177 of the foregoing embodiment and the roving is cut by the lower face of the roving holding lever 174 and the upper face of the nip piece 177, like scissors, this modification does not deviate from the scope of the present invention. The reciprocative movement of the roving holding lever across the roving guide groove 173 may be replaced by the parallel movement while securing the roving holding lever 174 to the operating bar 182. Moreover, when roving holding levers 174 of a plurality of roving-piecing heads 60 are operated by one operating bar 182, in order to ensure holding of the roving in each roving-piecing head 60, preferably a spring is interposed between the roving holding lever 174 and the operating bar 182.

According to the roving-piecing method of the present invention, roving-piecing can be accomplished by a simple operation in a short time during the operation of the spinning frame, and automation of the roving-piecing operation can be attained. Furthermore, by automatically performing the operation of hanging the roving of the full bobbin, in which roving piecing has been completed, on the roving guide, complete automation of roving-piecing and roving exchange can be attained. Moreover, if the roving-piecing head of the present invention is used for carrying out the above-mentioned roving-piecing method, roving-piecing can be assured.

Claims

1. A roving-piecing method for use in a roving exchange operation on a spinning frame when the wound diameter of a roving bobbin (1c) suspended from a bobbin hanger (19) and from which a roving (R) is withdrawn becomes small, wherein the end of a roving or a rotatably supported full bobbin (1a) to be exchanged with the small bobbin is taken out, said end of the roving is held and guided above a trumpet (6), said end of the roving is piled on the roving of the small bobbin during spinning, the end of the roving of the full bobbin is released, and then the roving of the small bobbin is cut to effect roving-piecing, characterized by moving a sucking opening of an end take-out nozzle (62) to a position opposite to a periphery of the full bobbin (1a), rotating the full bobbin (1a) in the rewinding direction, sucking the free end

- of the roving into the sucking opening of the end take-out nozzle (62), moving the sucking opening of the end take-out nozzle (62) to a position over a rovingpiecing head (60) to draw out a portion of the roving between the full bobbin (1a) and the sucking opening of the moved end take-out nozzle (62) and guide the drawnout portion of the roving to a roving guide groove (173) of the roving piecing head (60), operating a roving holding means (174) to hold the guided portion of the roving in the roving guide groove (173), moving the roving-piece head (60) to an upper position away from the trumpet (6) to put a roving (R) withdrawn from a small bobbin (1c) into the roving guide groove (173) of the roving-peicing head (60) and to pile with tee portion of the roving of the full bobbin (1a) in the roving guide groove (173), releasing the holding of the roving of the full bobbin in the roving-piecing head (60) so that the free end of the roving of the full bobbin (1a) can advance to a draft zone (5) with the roving (R) of the small bobbin (1c) before cutting the roving (R) of the small bobbin (1c) at a position upstream of the trumpet (6), whereby the free of the full bobbin (1a) is automatically pieced with the roving (R) of the small bobbin.
2. A roving-piecing method according to claim 1, wherein the roving (R) of the small bobbin (1c) is held upstream of the piled portion to cause the roving of the small bobbin (1c) to break during spinning.
 3. A roving-piecing method according to claim 1 or claim 2 comprising the further step of hanging the pieced roving withdrawn from the full bobbin (1a) on a roving guide (2).
 4. A roving-piecing method according to claim 1 or claim 2 wherein the pieced roving withdrawn from the full bobbin is guided above the roving guide (2) and is then laterally moved to hang the roving on the roving guide (2).
 5. A roving-piecing head (6) characterised by comprising a body (171) having a roving guide groove (173) formed in a top end portion thereof, a roving holding lever (174) mounted on the body (171) which is capable of reciprocating across said guide groove (173) and roving holding members (176,177) arranged on the body (171) on both sides of said guide groove (173) to co-operate with the roving holding lever (174) for holding a roving.
 6. A roving-piecing head according to claim 5,

further characterised in that the roving-piecing head (60b) comprises a roving guide member (201) having a roving guide groove (173) of the body (171) and a cam plate (204), and capable of being swingably pivotable of the body (171), and the roving-piecing head (60b) further comprises a spring (206) arranged to cause said roving guide member to abut against the body (171).

7. A roving-piecing method as claimed in any of claims 1 to 4 when performed with a roving-piecing head as claimed in claim 5 or claim 6.

15 Revendications

1. Procédé pour rattacher des mèches, utilisable dans une opération de changement de mèche sur un métier à filer lorsqu'une bobine de mèche (1c), qui est suspendue à un crochet pour bobine (19) et dont est tirée la mèche (R), a un diamètre d'enroulement qui devient faible, dans lequel on extrait l'extrémité d'une mèche d'une bobine pleine (1a) suspendue en rotation devant remplacer 1a bobine épuisée, et dans lequel ladite extrémité de mèche est maintenue et guidée au-dessus d'un cornet (6), ladite extrémité de mèche est superposée à la mèche de la bobine épuisée pendant le filage, l'extrémité de la mèche de la bobine pleine est relâchée, et la mèche de la bobine épuisée est ensuite sectionnée pour effectuer le rattachement des mèches, caractérisé en ce que l'on déplace une ouverture d'aspiration d'un ajutage (62) de prise d'extrémité jusqu'à une position faisant face à la périphérie de la bobine pleine (1a), on fait tourner la bobine pleine (1a) dans la direction du réenroulement, on aspire l'extrémité libre de la mèche dans l'ouverture d'aspiration de l'ajutage (62) de prise d'extrémité, on déplace l'ouverture d'aspiration de l'ajutage (62) de prise d'extrémité jusqu'à une position située au-dessus d'un dispositif pour rattacher les mèches (60) afin de dévider une partie de mèche entre la bobine pleine (1a) et l'ouverture d'aspiration de l'ajutage (62) de prise d'extrémité déplacé et on guide la partie dévidée de la mèche vers une rainure guidemèche (173) du dispositif pour rattacher les mèches (60), on manoeuvre un moyen (174) de maintien des mèches pour maintenir la partie guidée de la mèche dans la rainure guide-mèche (173), on déplace le dispositif pour rattacher les mèches (60) jusqu'à une position supérieure éloignée du cornet (6) afin de placer une mèche (R), tirée d'une bobine épuisée (1c), dans la rainure guide-mèche (173) du dispositif pour rattacher les mèches

- (60) et de la superposer avec la partie de mèche de la bobine pleine (1a) qui se trouve dans la rainure guide-mèche (173), on relâche le maintien de la mèche de la bobine pleine dans le dispositif pour rattacher les mèches (60) afin que l'extrémité libre de la mèche de la bobine pleine (1a) puisse avancer jusqu'à une zone de tirage (5) avec la mèche (R) de la bobine épuisée (1c) avant de sectionner la mèche (R) de la bobine épuisée (1c) en une position en amont du cornet (6), de façon que l'extrémité libre de la bobine pleine (1a) soit automatiquement rattachée à la mèche (R) de la bobine épuisée.
2. Procédé pour rattacher des mèches selon la revendication 1, dans lequel la mèche (R) de la bobine épuisée (1c) est maintenue en amont de la partie superposée pour faire casser la mèche de la bobine épuisée (1c) pendant le filage.
 3. Procédé pour rattacher des mèches selon la revendication 1 ou 2, comprenant en outre l'opération supplémentaire consistant à suspendre sur un guide-mèche (2) la mèche rattachée tirée de la bobine pleine (1a).
 4. Procédé pour rattacher des mèches selon la revendication 1 ou 2, dans lequel la mèche rattachée tirée de la bobine pleine est guidée au-dessus du guide-mèche (2) puis déplacée latéralement pour suspendre la mèche sur le guide-mèche (2).
 5. Dispositif pour rattacher des mèches (60) caractérisé en ce qu'il comprend un corps (171) ayant une rainure guide-mèche (173) formée dans sa partie d'extrémité supérieure, un levier (174) de maintien des mèches monté sur le corps (171) et susceptible d'un mouvement de va-et-vient à travers ladite rainure de guidage (173), et des organes (176, 177) des deux côtés de ladite rainure de guidage (173) pour coopérer avec le levier (174) de maintien de mèche afin de maintenir une mèche.
 6. Dispositif pour rattacher des mèches selon la revendication 5, caractérisé en outre en ce que le dispositif pour rattacher les mèches (60b) comporte un organe guide-mèche (201) comportant une rainure guide-mèche (203) qui peut communiquer avec la rainure guide-mèche (173) sur le corps (171) et une plaque formant came (204) et susceptible d'être monté pivotant sur le corps (171), et en ce que le dispositif pour rattacher les mèches (60b) comprend en outre un ressort (206) agencé pour faire

buter ledit organe guide-mèche contre le corps (171).

7. Procédé pour rattacher des mèches selon l'une quelconque des revendications 1 à 4 lorsqu'il est exécuté au moyen d'un dispositif pour rattacher des mèches tel que revendiqué dans la revendication 5 ou 6.

10 Patentansprüche

1. Verfahren zum Verbinden von Vorgarn in einem Vorgarnaustauscharbeitsgang auf einer Spinnmaschine, wenn der aufgewickelte Durchmesser einer Vorgarnspule (1c), die an einer Hängespulenvorrichtung (19) aufgehängt ist und von welcher ein Vorgarn (R) abgezogen wird, klein wird, wobei das Ende eines Vorgarns oder eine drehbar gelagerte, gegen die kleine Spule auszuwechselnde volle Spule (1a) herausgenommen wird, das Ende des Vorgarns oberhalb eines Spinntrichters (6) gehalten und geführt wird und das Ende des Vorgarns auf das Vorgarn der kleinen Spule während des Spinnens abgelegt wird, das Ende des Vorgarns der vollen Spule freigegeben wird, und dann das Vorgarn der kleinen Spule abgeschnitten wird, um ein Vorgarnverbinden durchzuführen, dadurch gekennzeichnet, daß eine Saugöffnung einer Endentnahmedüse (62) in eine Stellung gegenüber eines Umfangs der vollen Spule (1a) bewegt wird, die volle Spule (1a) in die Umspülrichtung gedreht wird, das freie Ende des Vorgarns in die Saugöffnung der Endentnahmedüse (62) gesaugt wird, die Saugöffnung der Endentnahmedüse (62) in eine Stellung oberhalb eines Vorgarnverbindungskopfs (60) bewegt wird, um einen Teil des Vorgarns zwischen der vollen Spule (1a) und der Saugöffnung der bewegten Endentnahmedüse (62) herauszuziehen und den herausgezogenen Teil des Vorgarns zu einer Vorgarnführungsnut (173) des Vorgarnverbindungskopfs (60) zu führen, eine Vorgarnhalteeinrichtung (174) betätigt wird, um den geführten Teil des Vorgarns in der Vorgarnführungsnut (173) zu halten, den Vorgarnverbindungskopf (60) in eine obere Stellung weg von dem Spinntrichter zu bewegen, um ein von der kleinen Spule (1c) abgezogenes Vorgarn (R) in die Vorgarnführungsnut (173) des Vorgarnverbindungskopfs (60) zu legen und es mit dem Teil des Vorgarns der vollen Spule (1a) in der Vorgarnführungsnut (173) abzulegen, wobei die Halterung des Vorgarns der vollen Spule in dem Vorgarnverbindungskopf (60) freigegeben wird, sodaß das freie Ende des Vorgarns der vollen Spule (1a) in eine Streckzone (5) vorge-

- schoben werden kann, wobei sich das Vorgarn (R) der kleinen Spule (1c) vor dem Abschneiden des Vorgarns (T) der kleinen Spule (1c) in einer Stellung oberhalb des Spinntrichters (6) befindet, wodurch das freie Ende der vollen Spule (1a) automatisch mit dem Vorgarn (R) der kleinen Spule verbunden wird. 5
2. Vorgarnverbindungsverfahren nach Anspruch 1, dadurch gekennzeichnet, daß das Vorgarn (R) der kleinen Spule (1c) oberhalb des abgelegten Teils gehalten wird, um zu bewirken, daß das Vorgarn der kleinen Spule (1c) während des Spinnens bricht. 10
3. Vorgarnverbindungsverfahren nach Anspruch 1 oder 2, dadurch gekennzeichnet, daß das verbundene Vorgarn, das von der vollen Spule (1a) abgezogen ist, auf eine Vorgarnführung (2) gehängt wird. 15 20
4. Vorgarnverbindungsverfahren nach Anspruch 1 oder 2, dadurch gekennzeichnet, daß das von der vollen Spule abgezogene, verbundene Vorgarn oberhalb der Vorgarnführung (2) geführt wird und dann seitwärts bewegt wird, um das Vorgarn auf die Vorgarnführung (2) zu hängen. 25
5. Vorgarnverbindungskopf (6) dadurch gekennzeichnet, daß er einen Körper (171) aufweist, der eine in dem oberen Endteil des Körpers ausgebildete Vorgarnführungsnut (173), einen auf dem Körper (171) angebrachten Vorgarnhaltehebel (174), welcher sich über die Führungsnut (173) hin- und herbewegen kann und Vorgarnhalteelemente (176,177) aufweist, die auf dem Körper (171) auf beiden Seiten der Führungsnut (173) angeordnet sind, um mit dem Vorgarnhaltehebel (174) zum Halten eines Vorgarns zusammenzuwirken. 30 35 40
6. Vorgarnverbindungskopf nach Anspruch 5, dadurch gekennzeichnet, daß der Vorgarnverbindungskopf (60b) ein Vorgarnführungselement (201), welches eine Vorgarnführungsnut (173) des Körpers (171) und eine Nockenplatte aufweist, die schwenkend drehbar von dem Körper (171) sein kann, aufweist, und der Vorgarnverbindungskopf (60b) außerdem eine Feder (206) aufweist, die angeordnet ist, um zu bewirken, daß das Vorgarnführungsglied gegen den Körper (171) stößt. 45 50
7. Vorgarnverbindungsverfahren nach einem der Ansprüche 1 bis 4, das mit einem Vorgarnverbindungskopf nach Anspruch 5 oder 6 durchgeführt wird. 55

Fig. 2

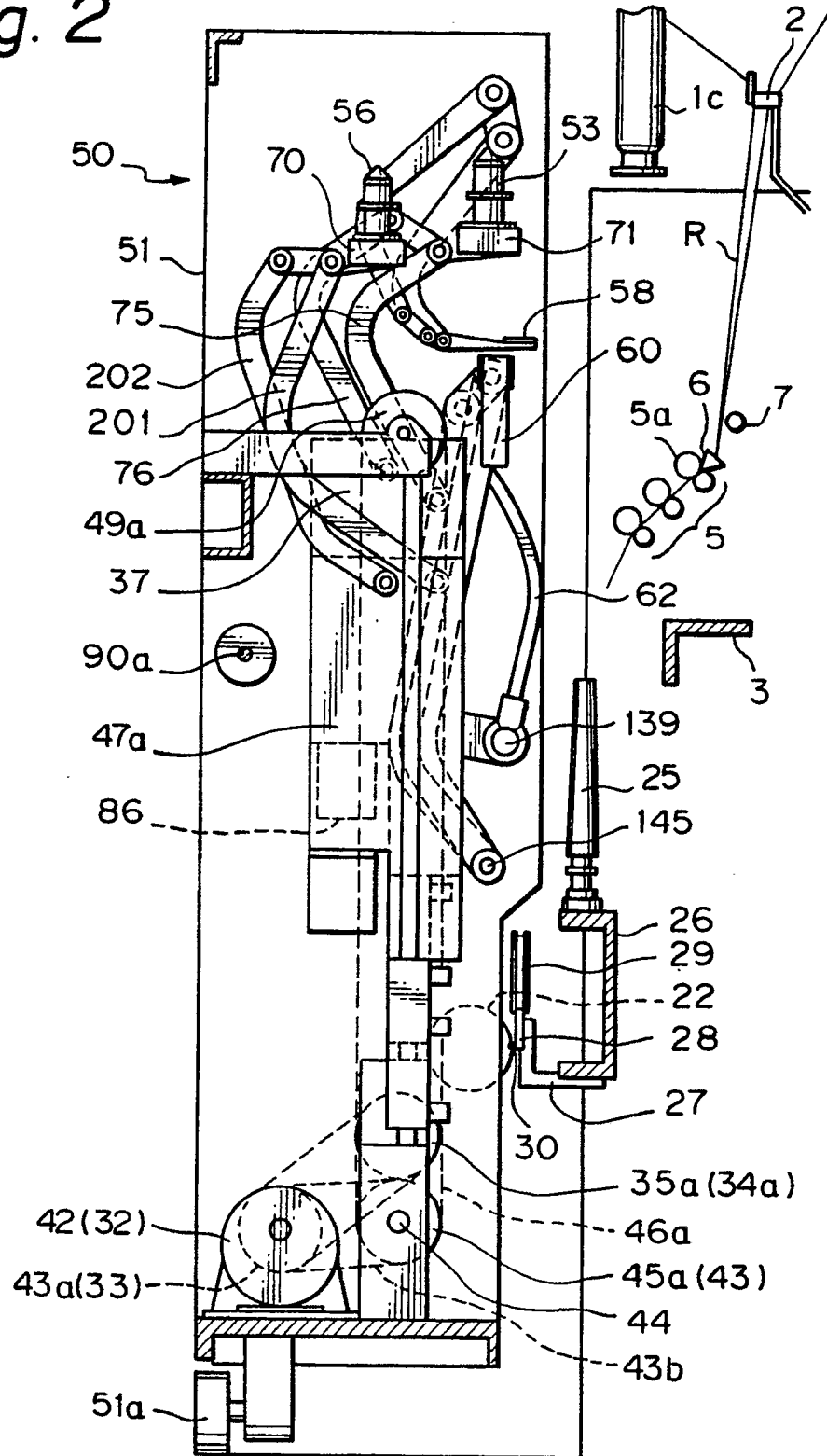

Fig. 3

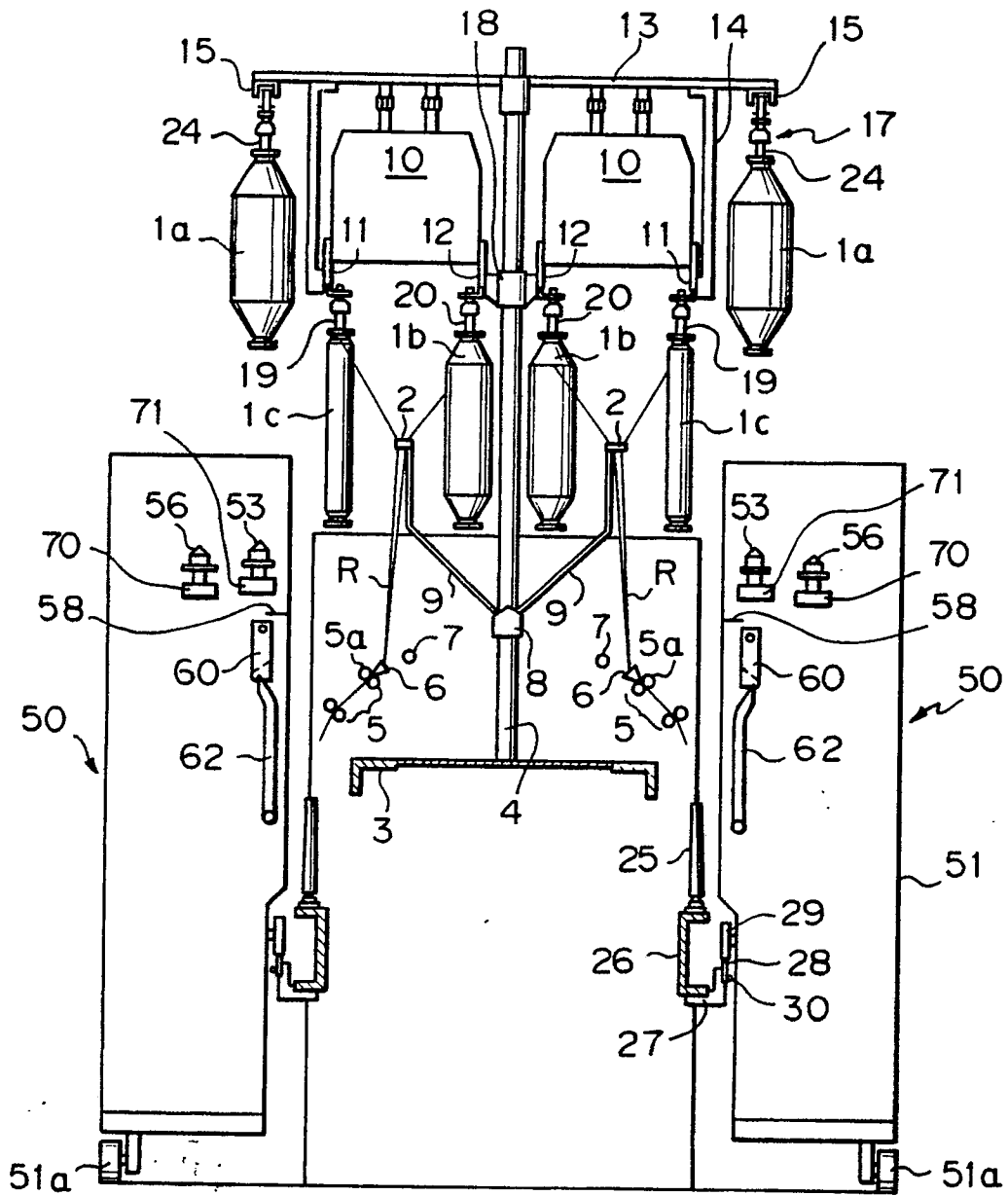

Fig. 4

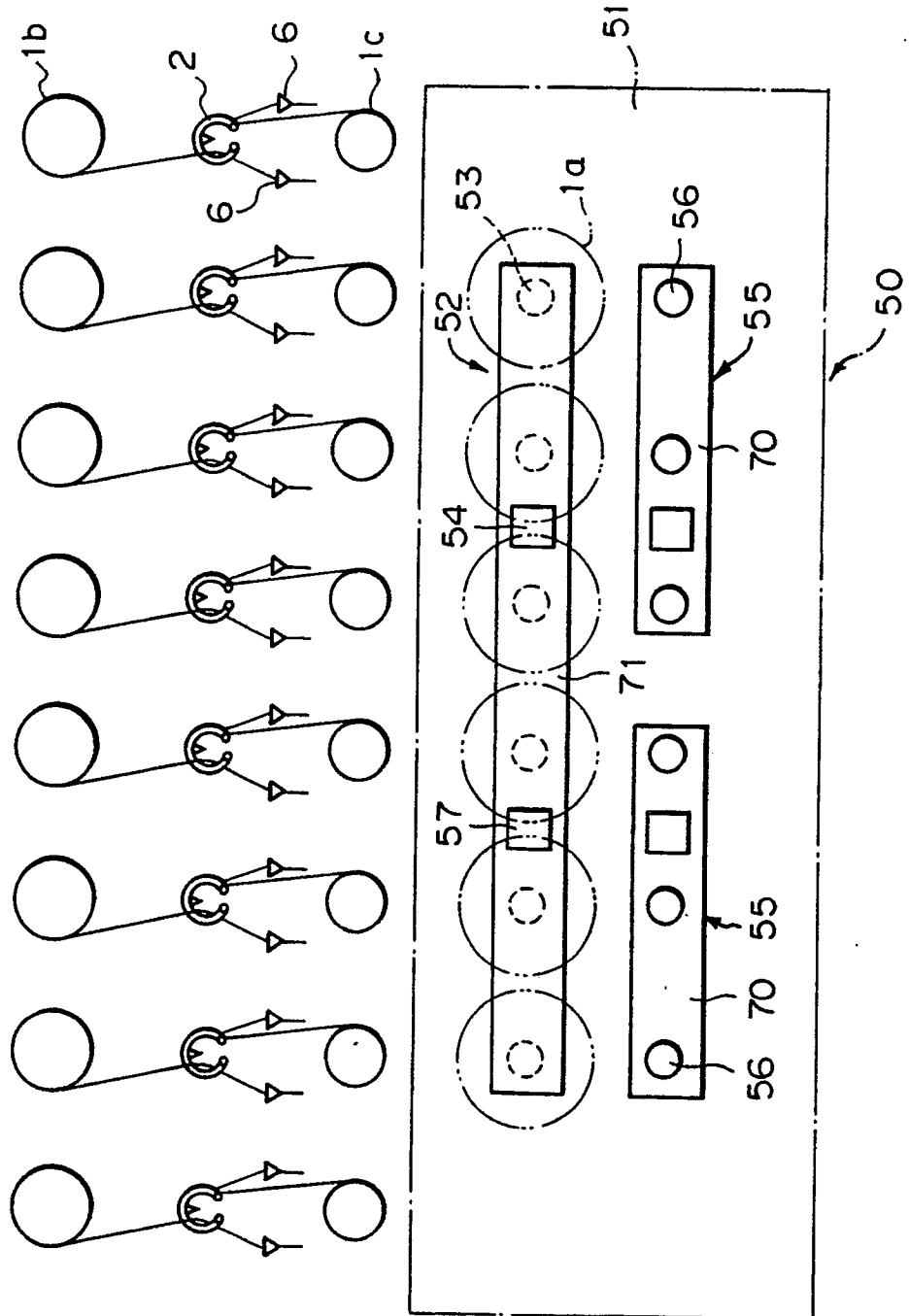

Fig. 5

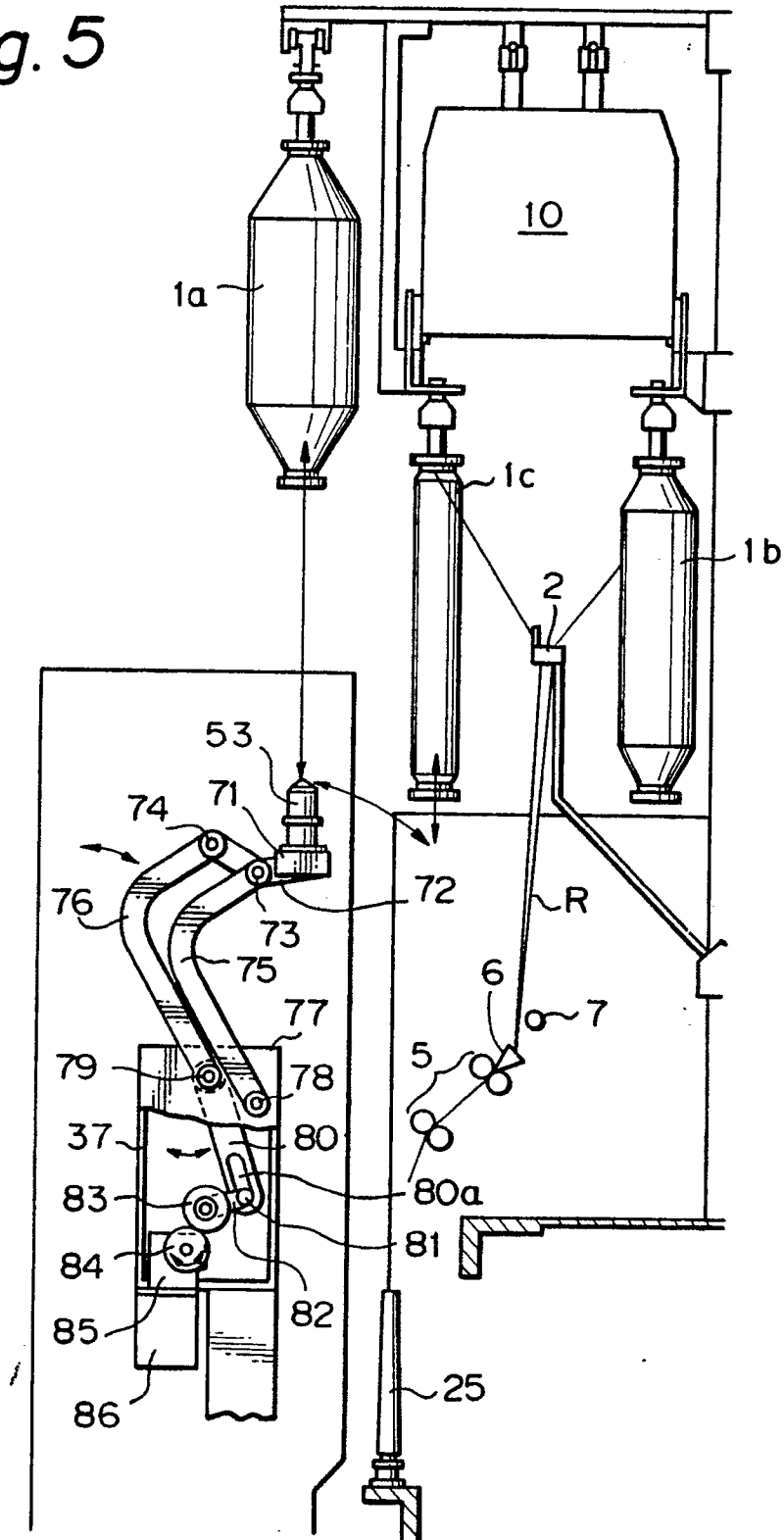

Fig. 6

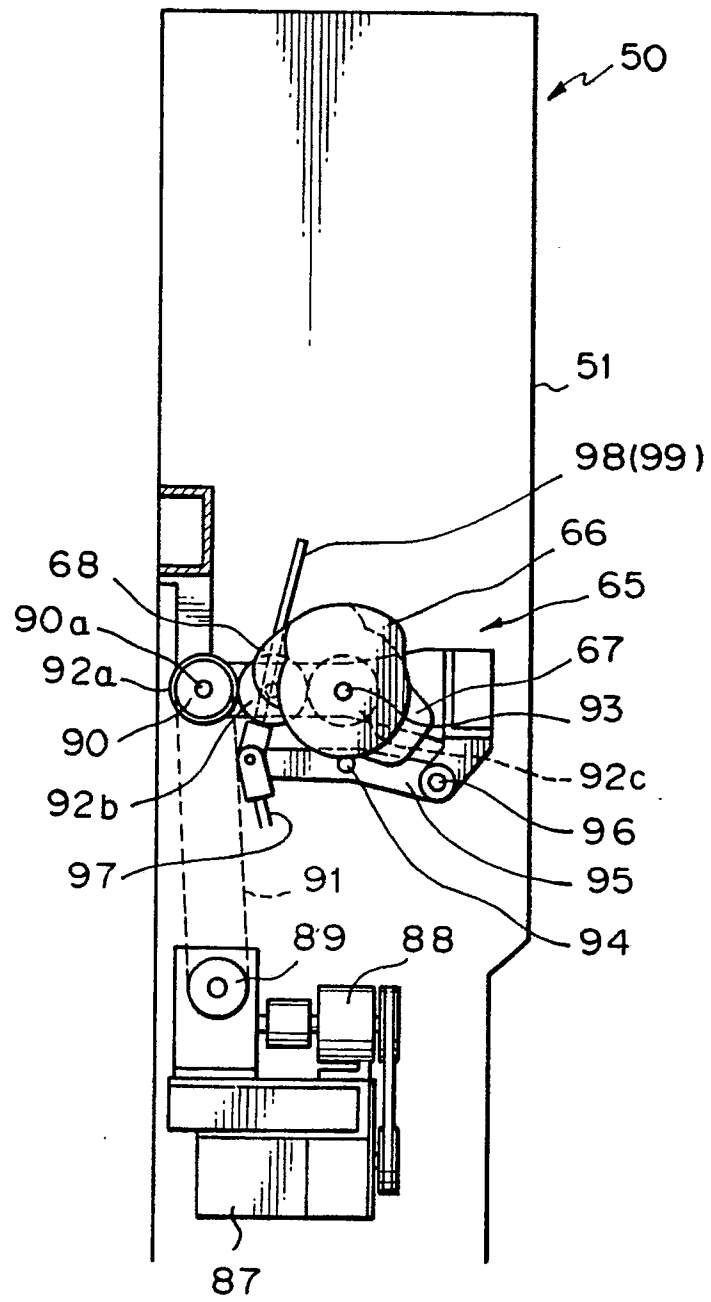

Fig. 7

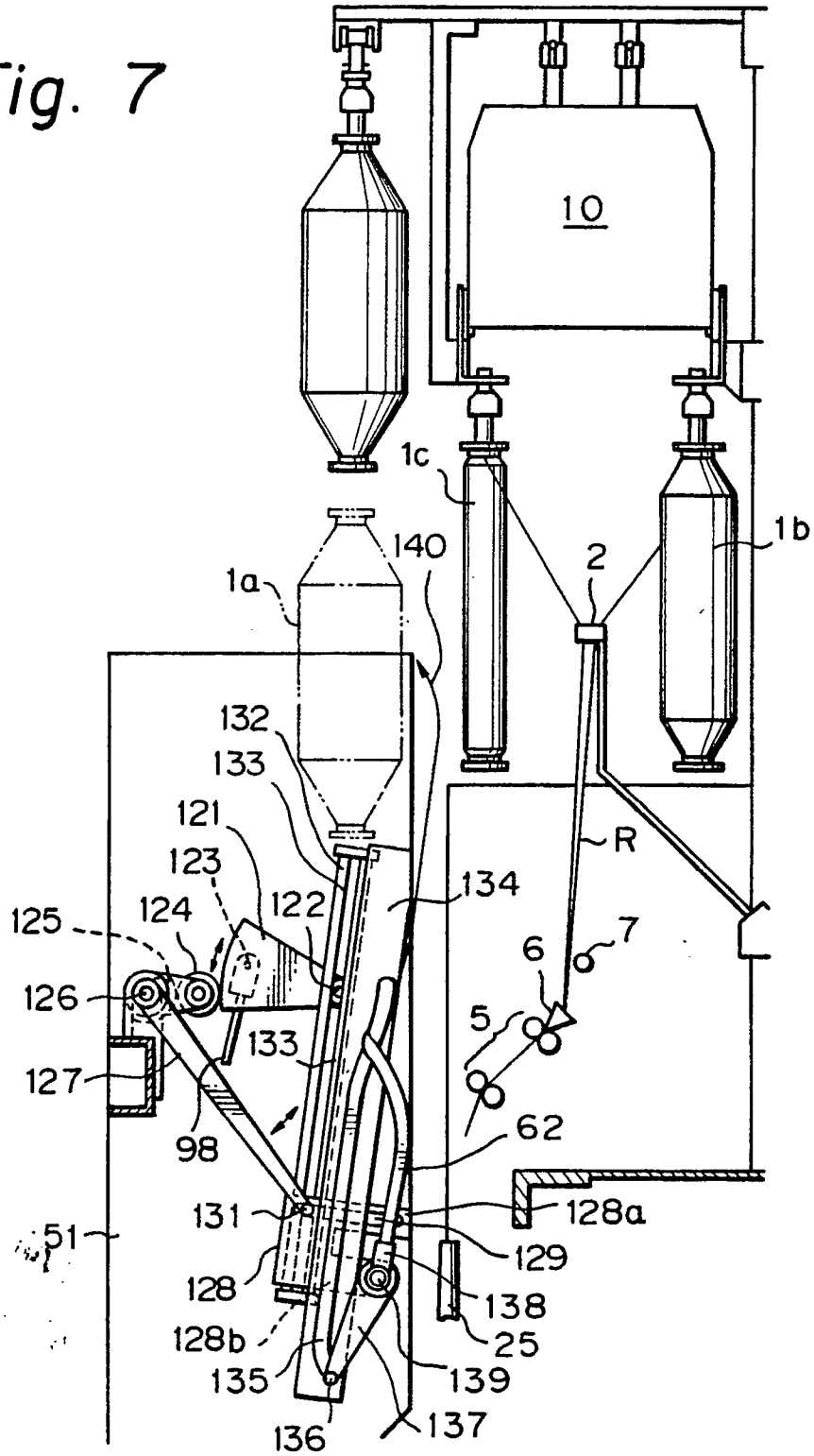

Fig. 8

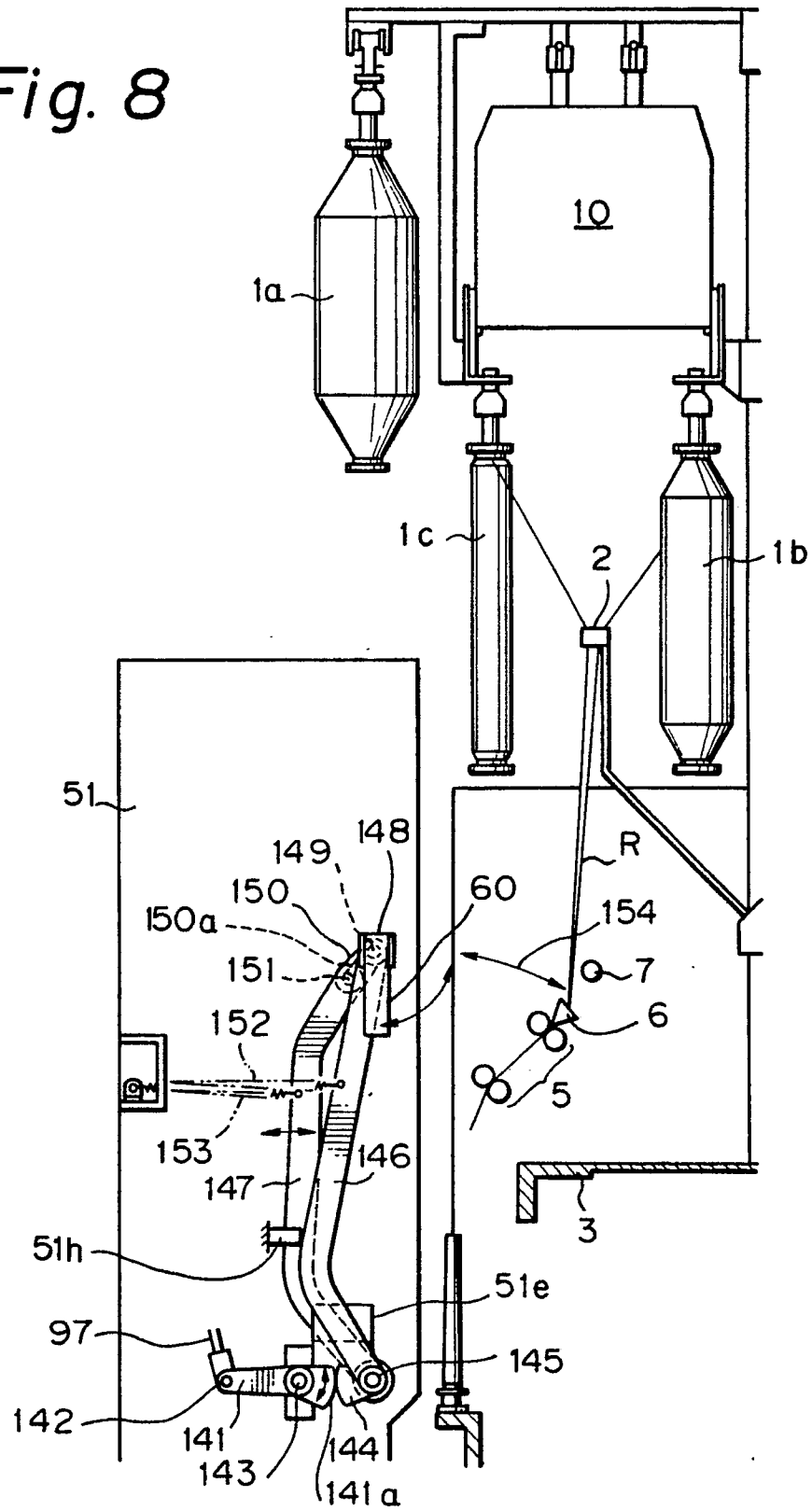

Fig. 9

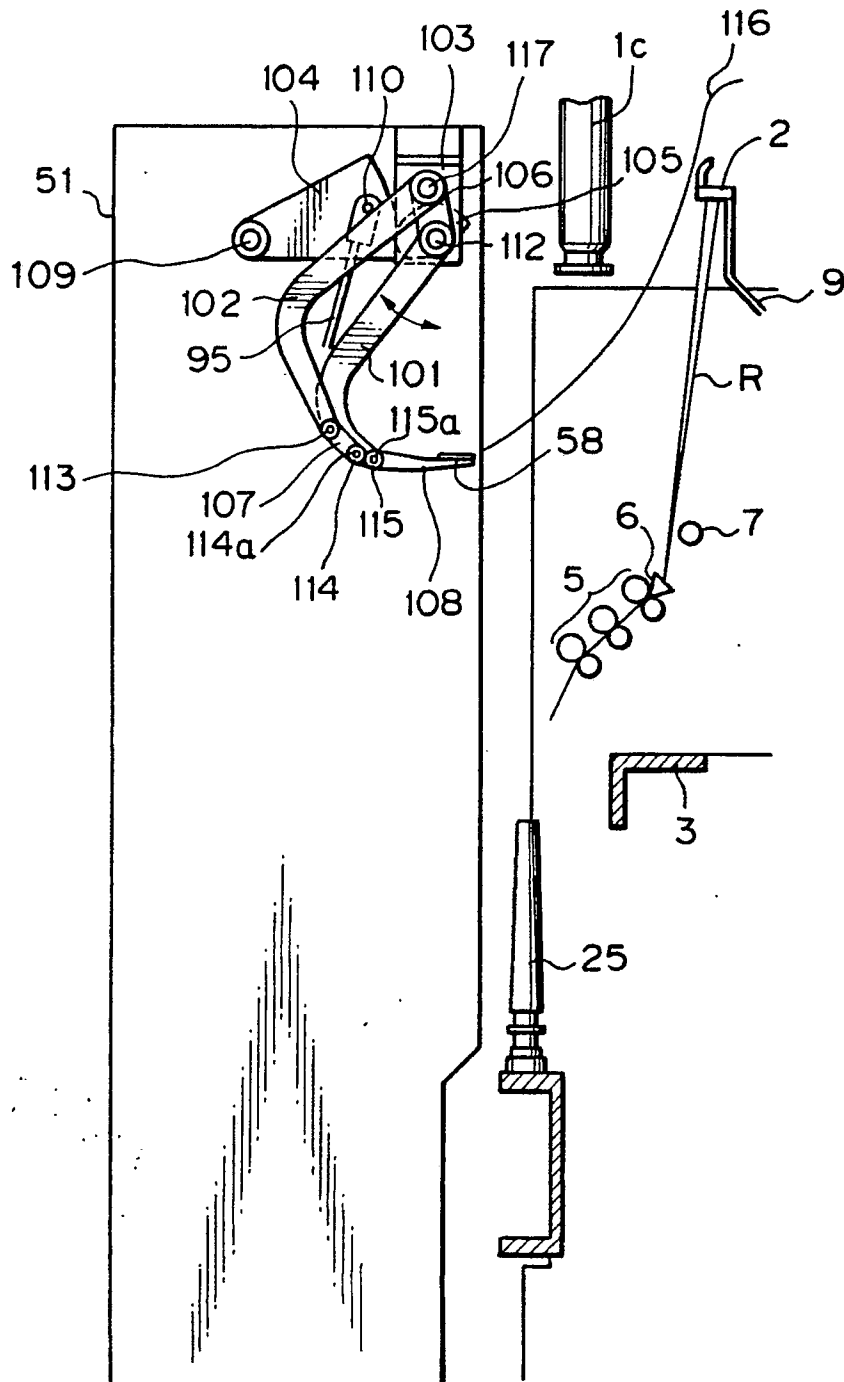

Fig. 10

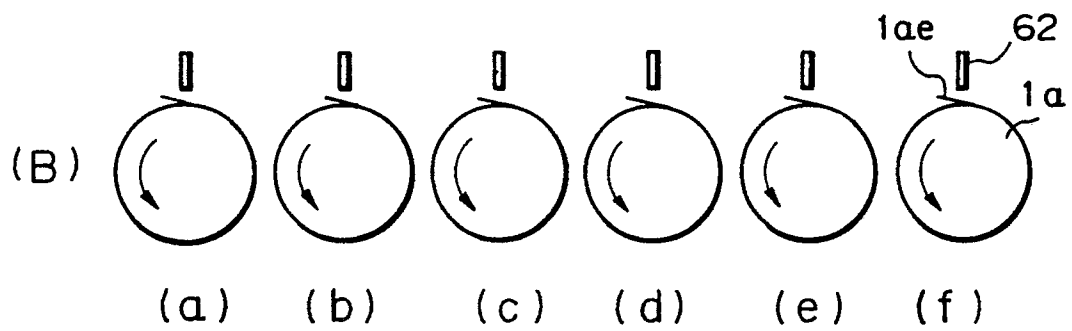
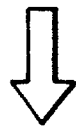
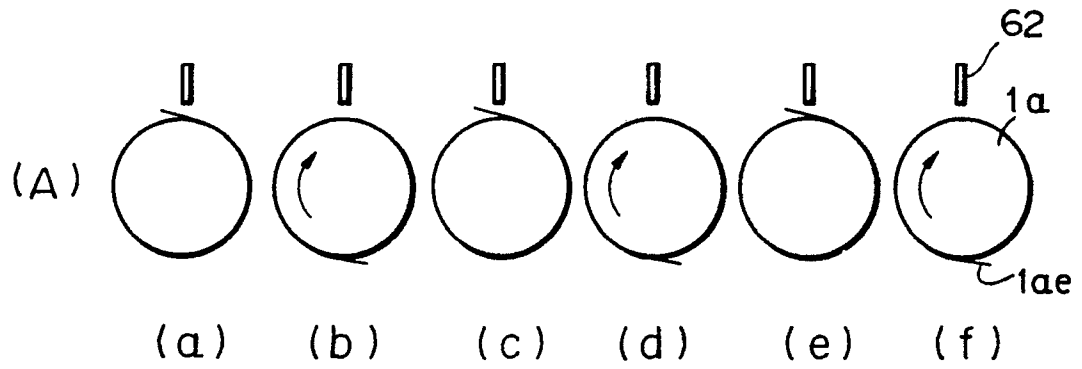

Fig. 11

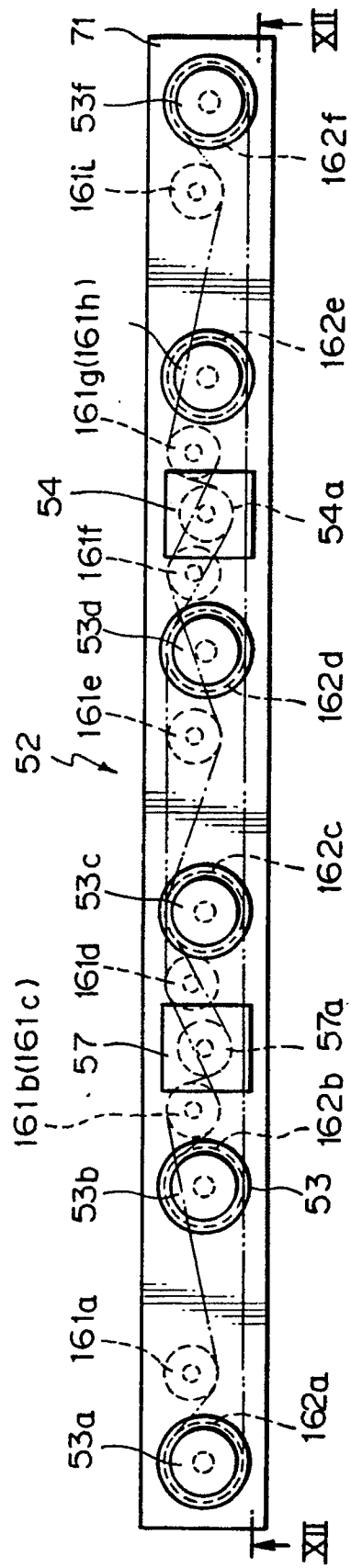

Fig. 12

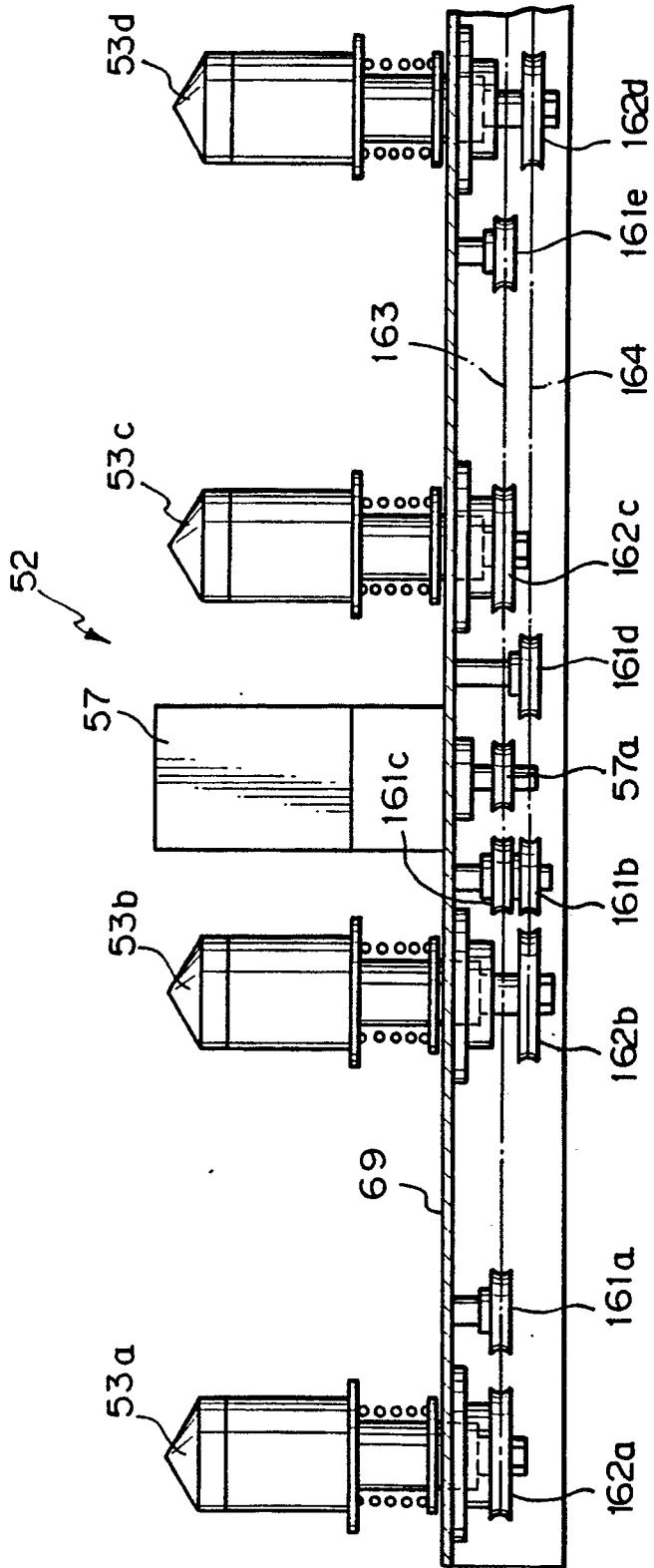

Fig. 13

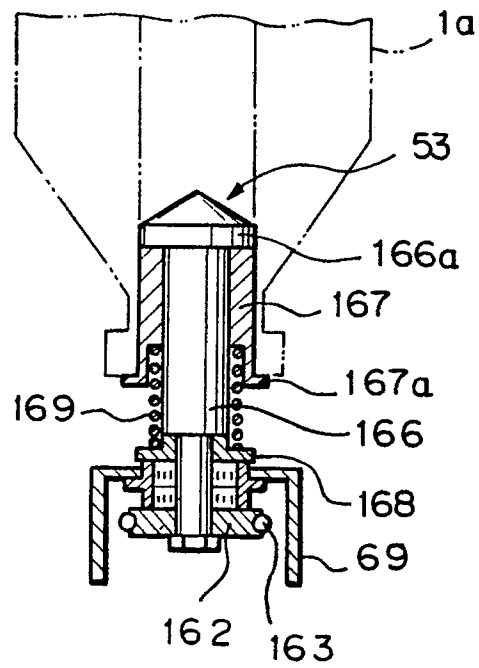

Fig. 14

(C)

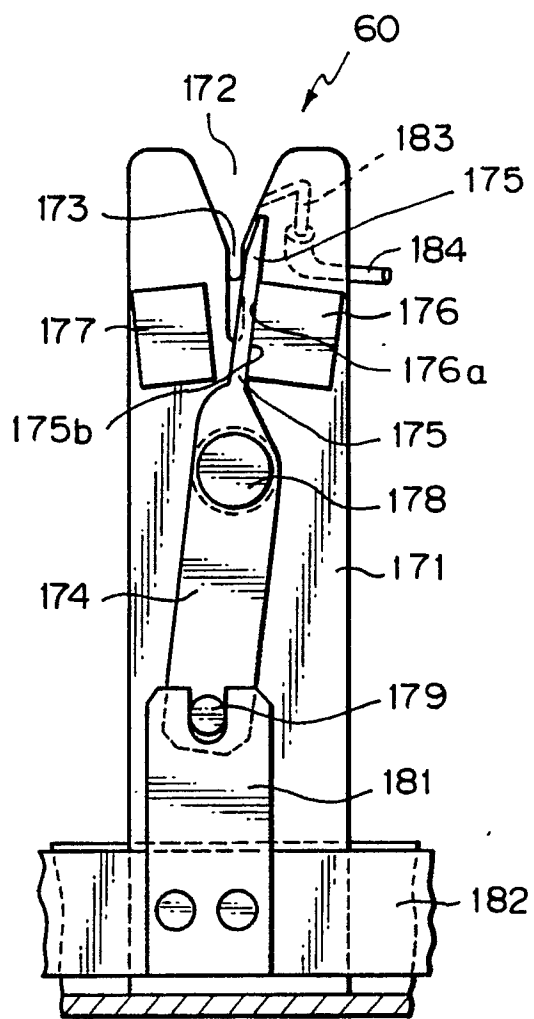

Fig. 15

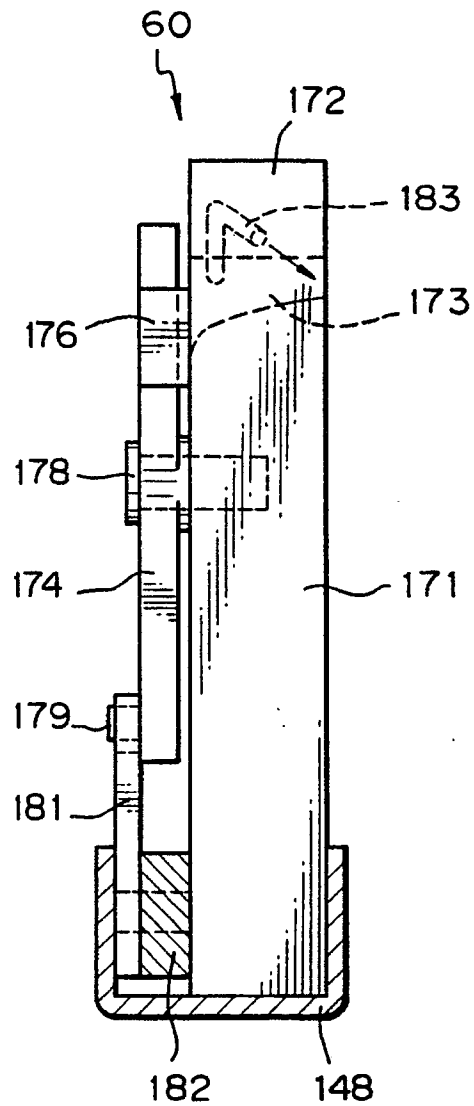

Fig. 16

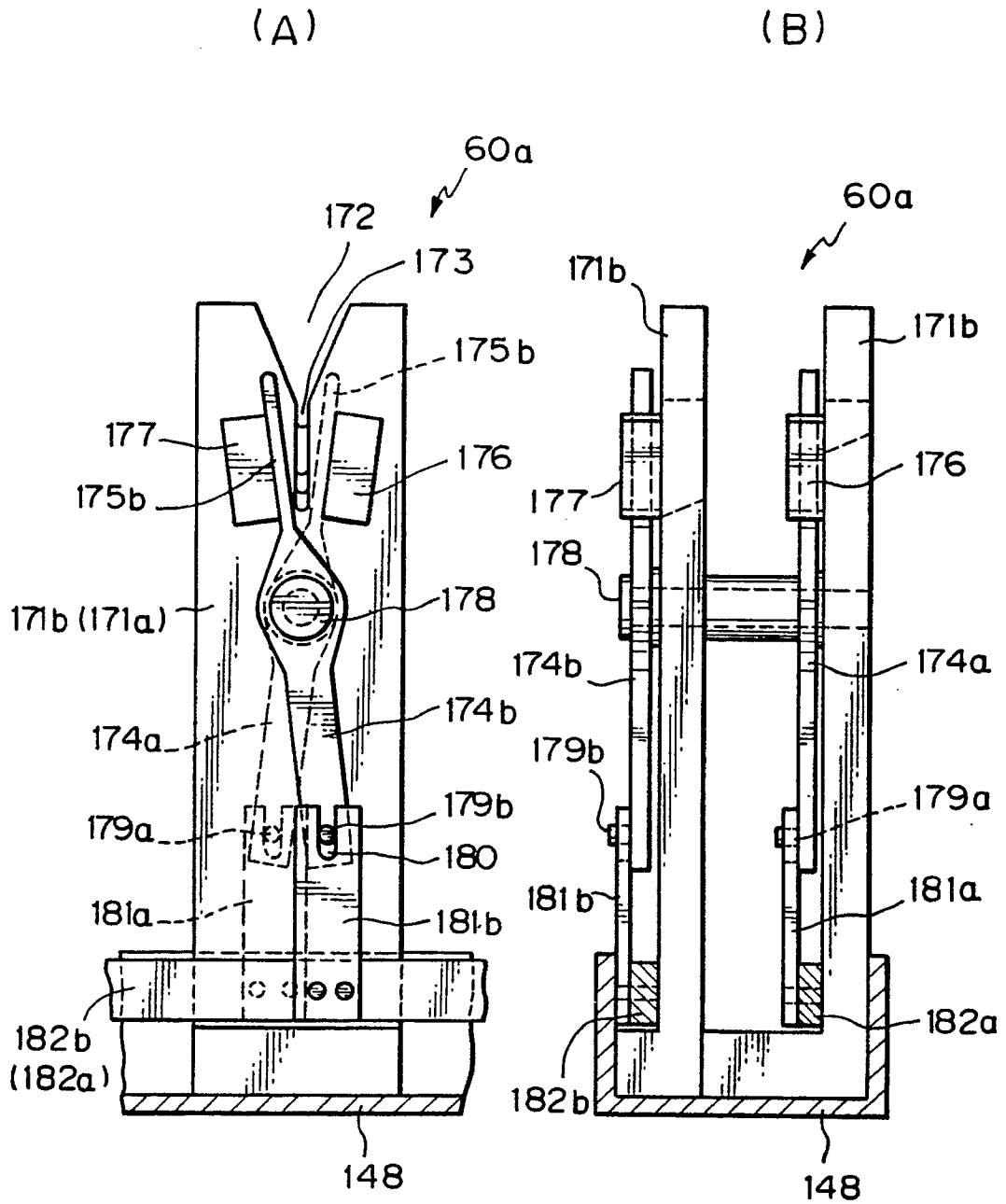
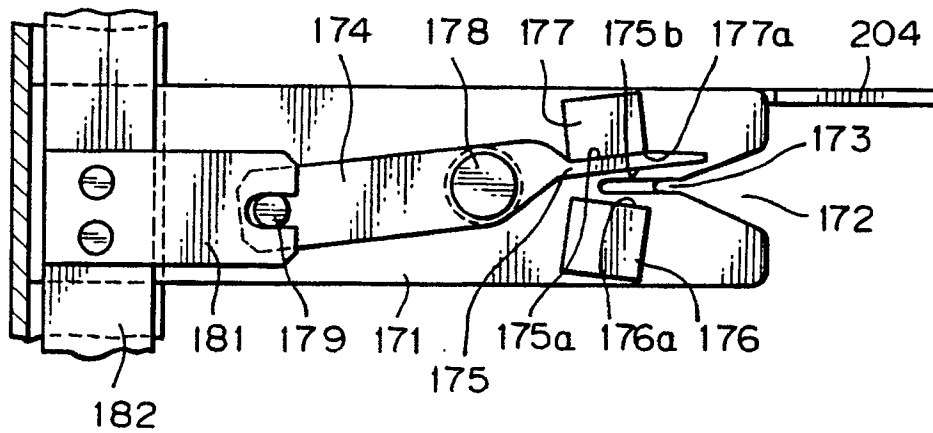

Fig. 17

(A)



(B)

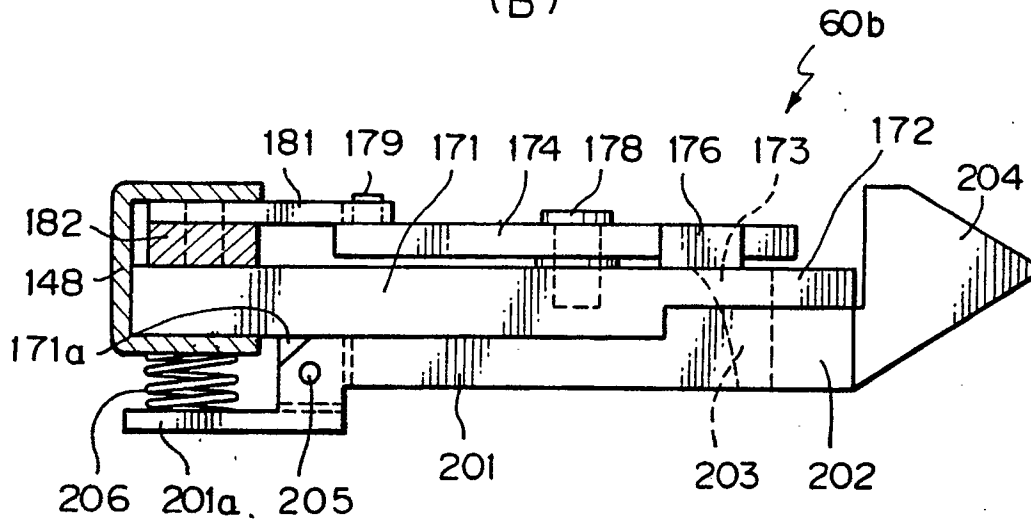

Fig. 18

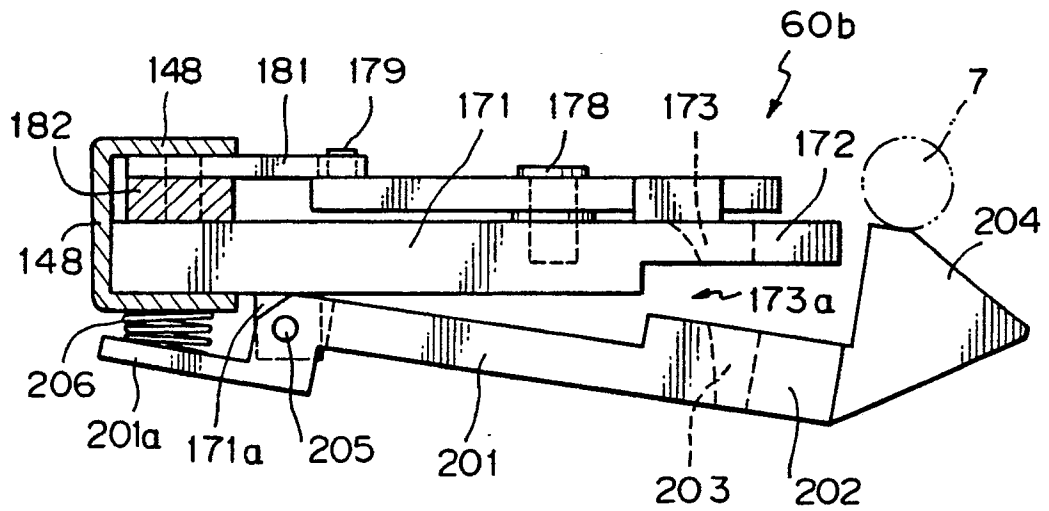
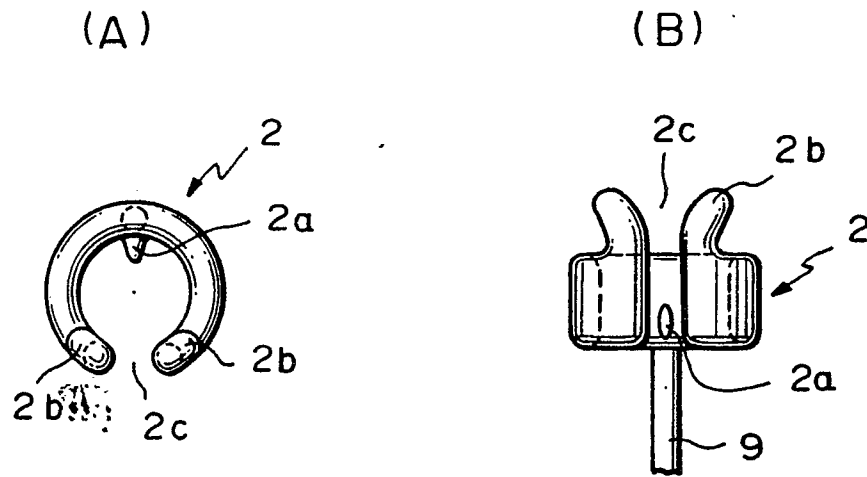

Fig. 20



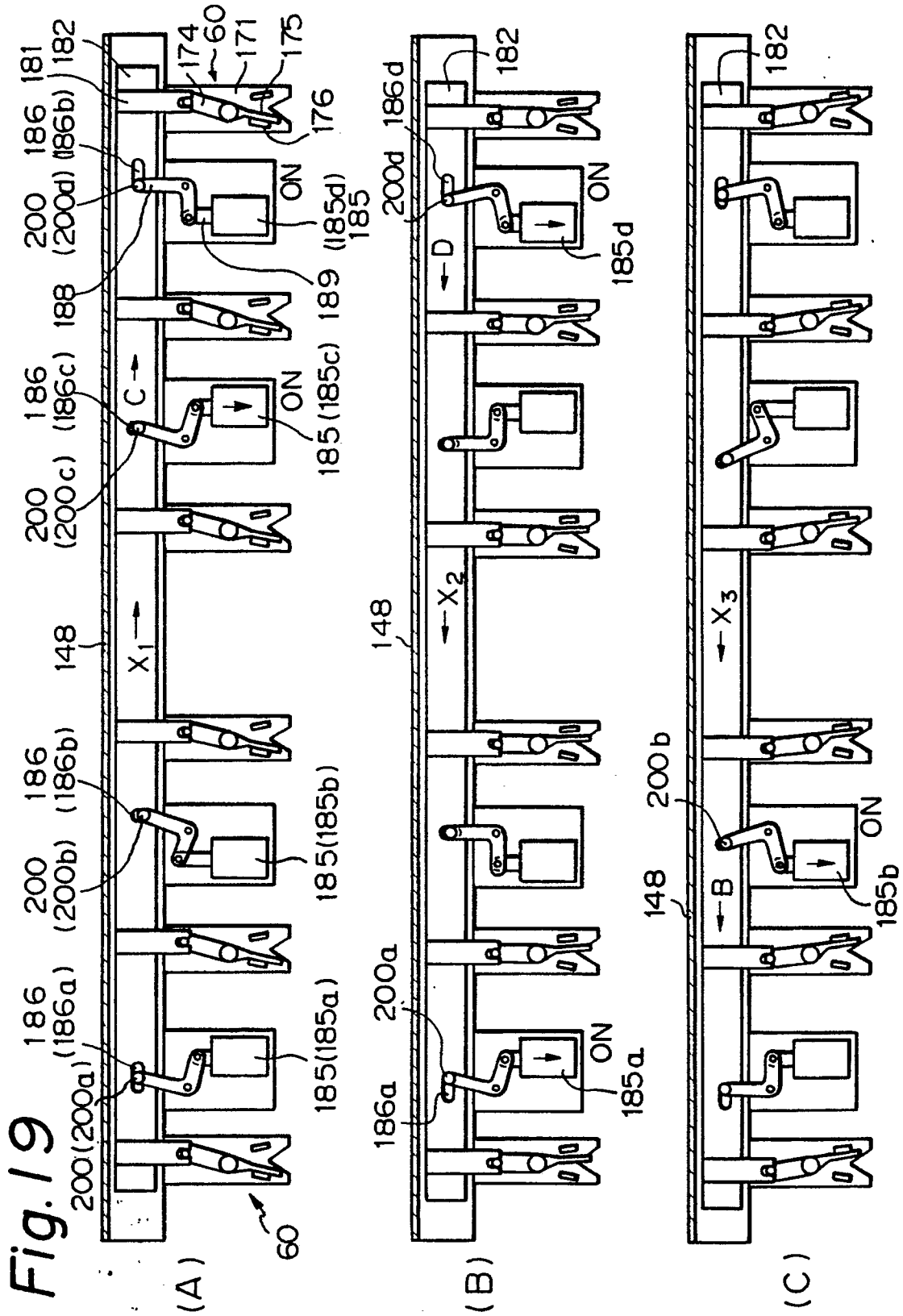

Fig. 21

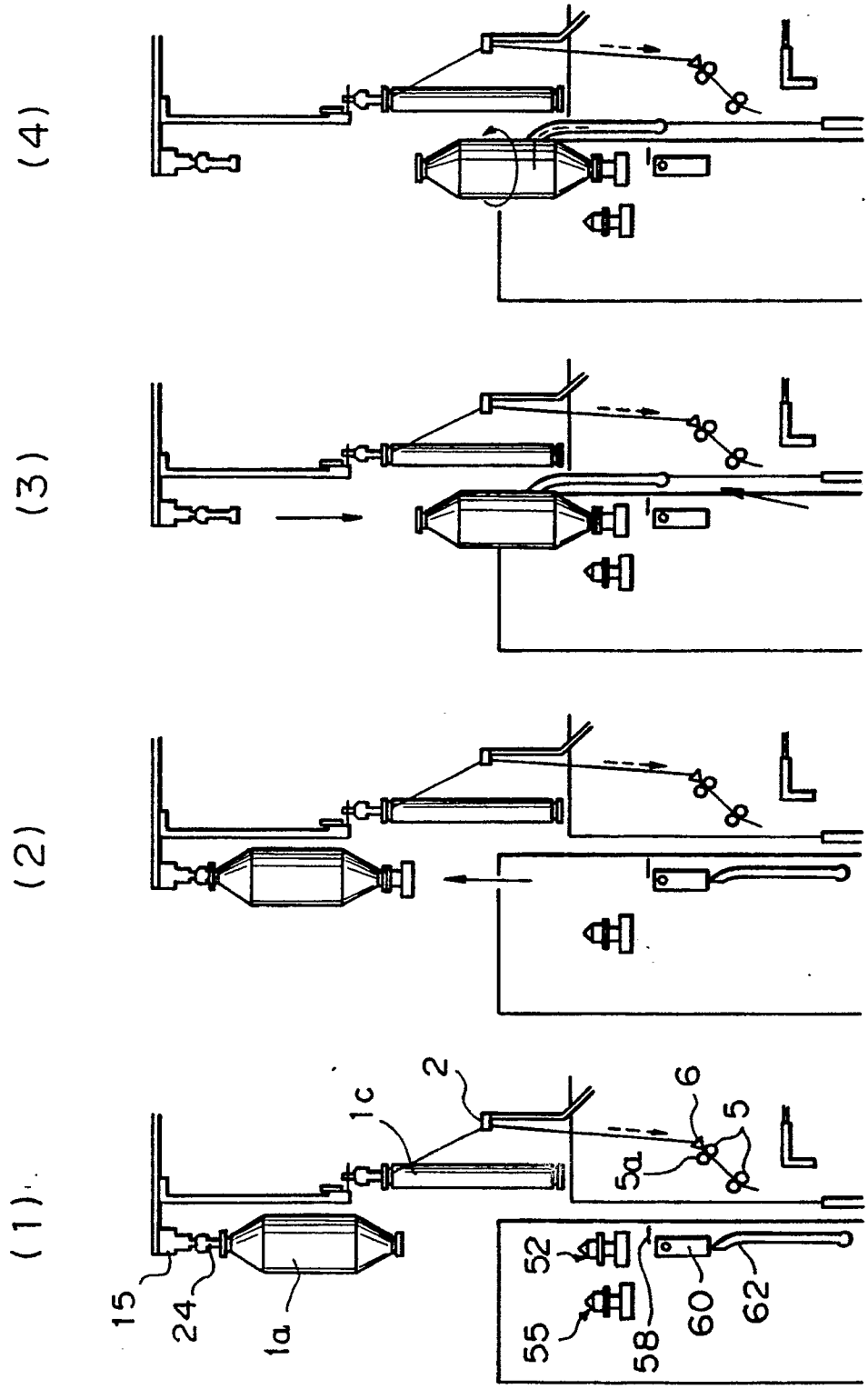

Fig. 21

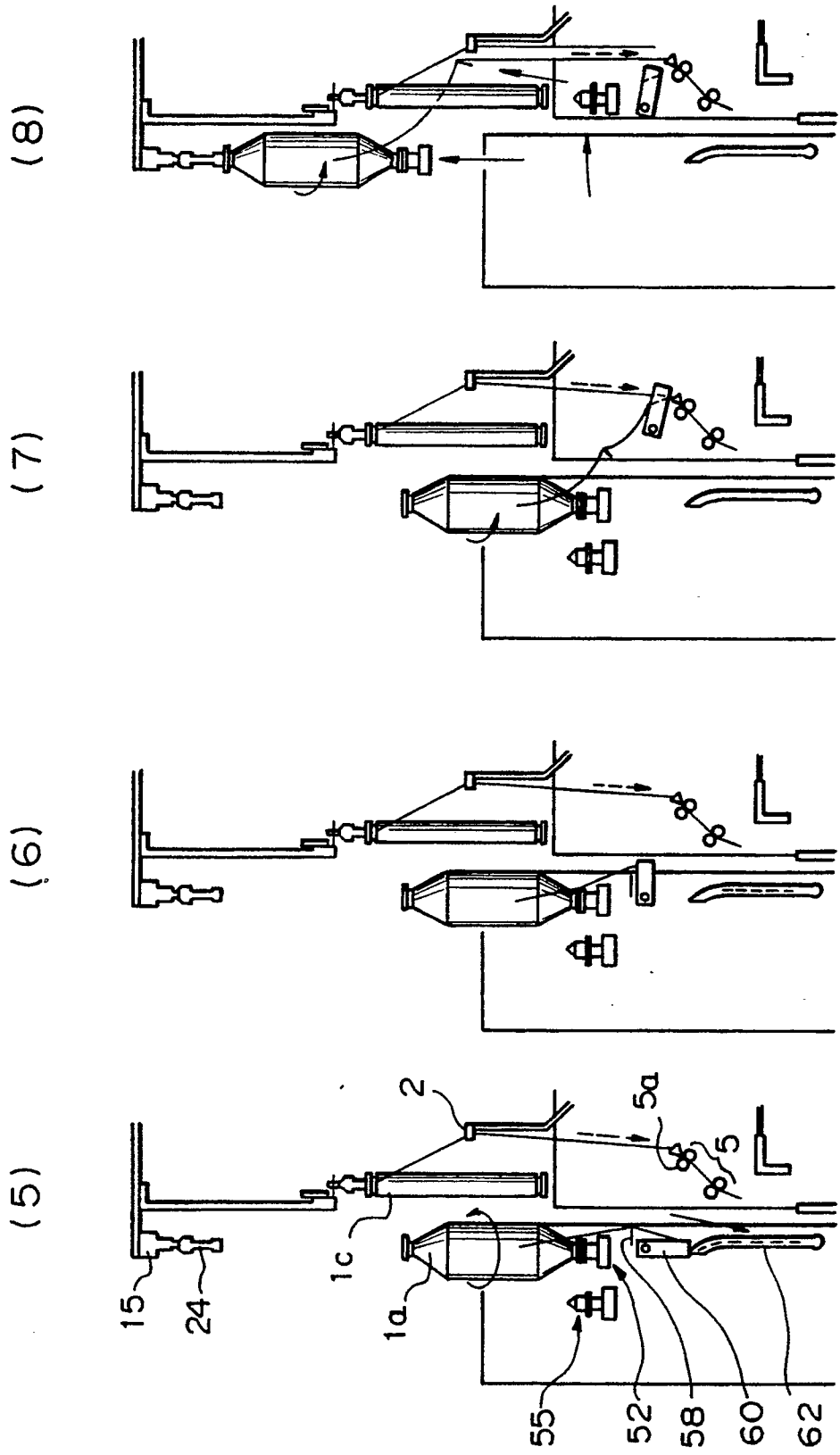

Fig. 21

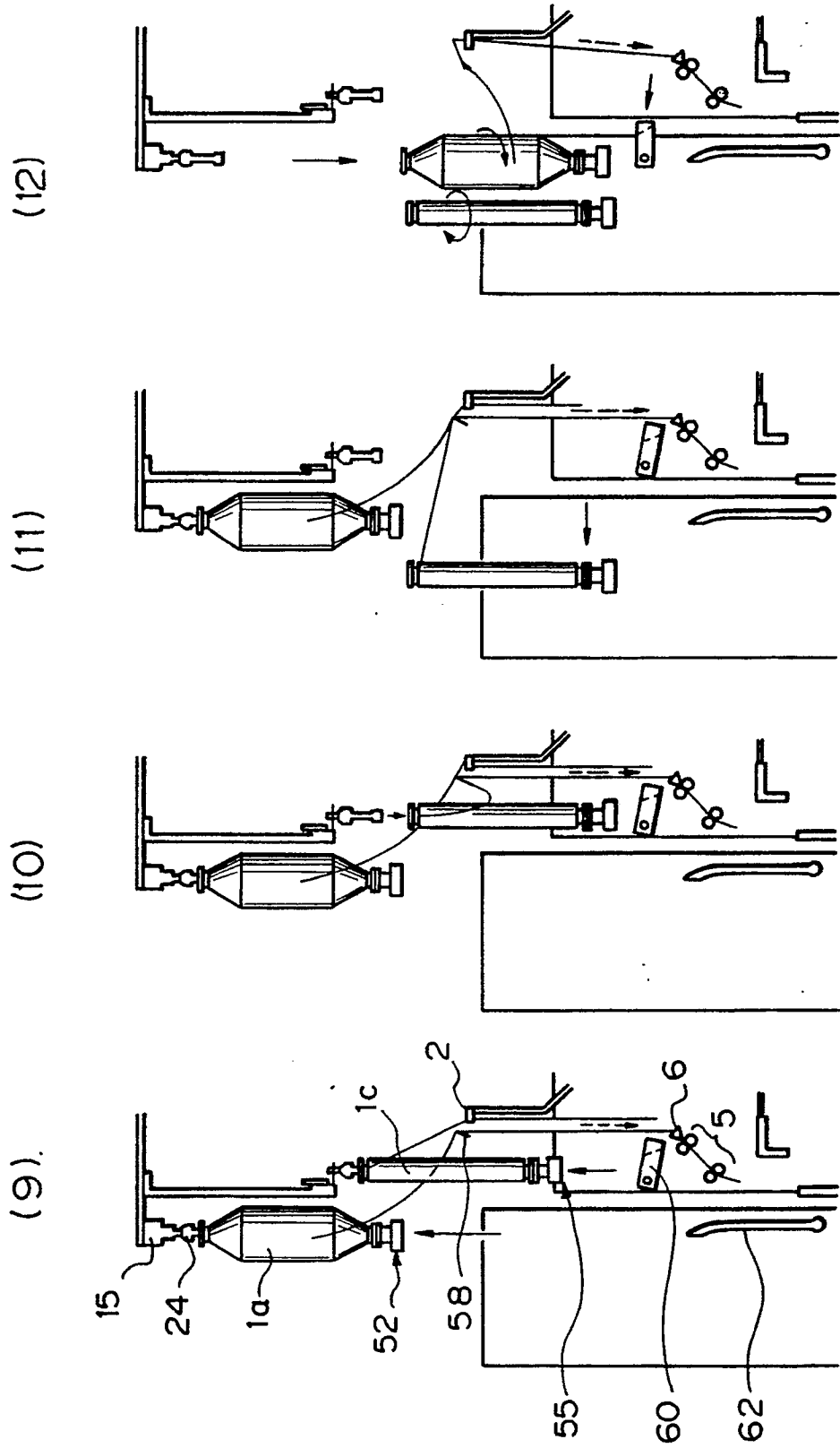

Fig. 21

