

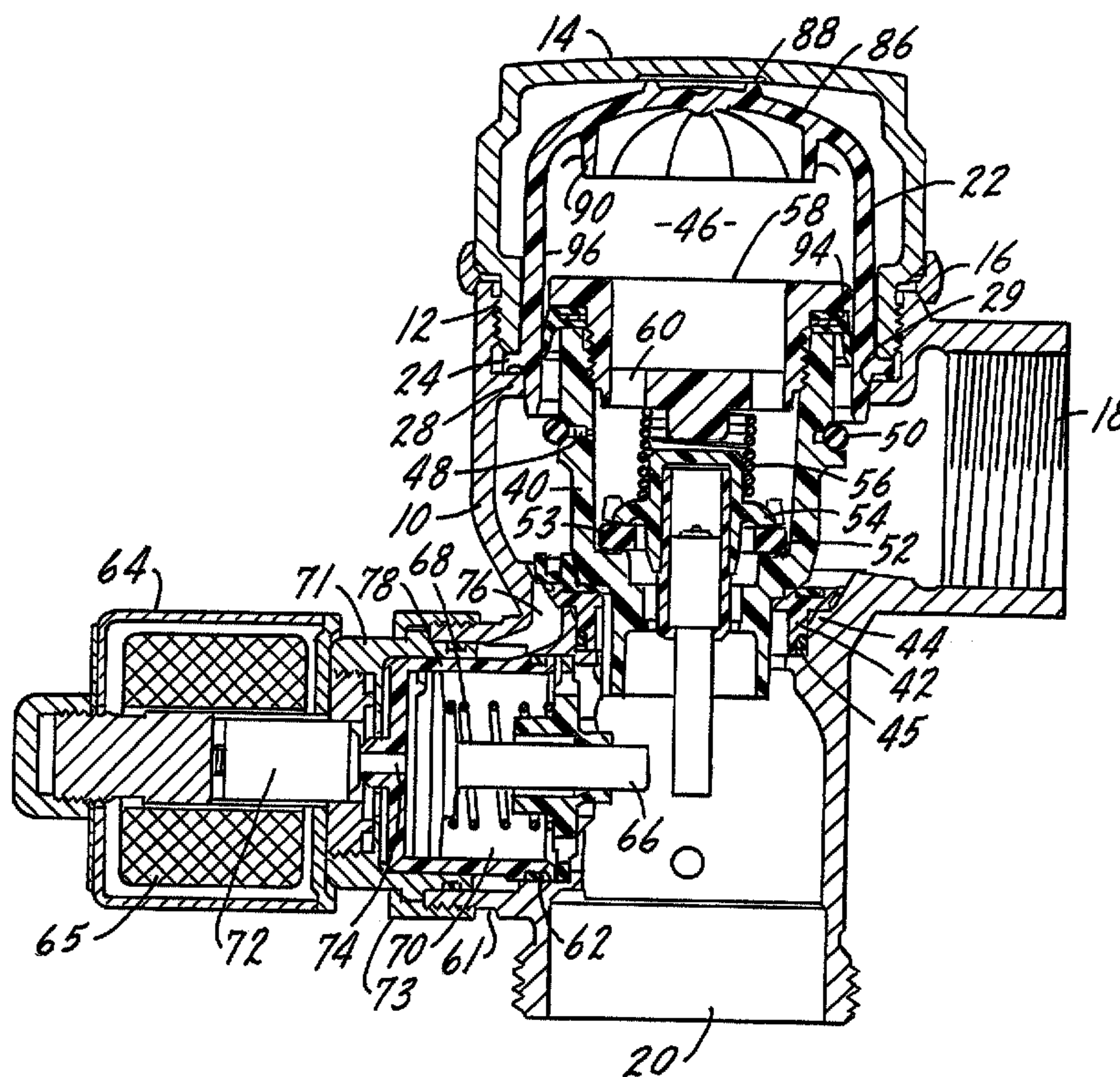

(22) Date de dépôt/Filing Date: 2004/10/06
(41) Mise à la disp. pub./Open to Public Insp.: 2005/04/23
(30) Priorité/Priority: 2003/10/23 (10/691,991) US

(51) Cl.Int.⁷/Int.Cl.⁷ E03D 3/04, F16K 31/143
(71) Demandeur/Applicant:
SLOAN VALVE COMPANY, US
(72) Inventeur/Inventor:
NORTIER, RICHARD A., US
(74) Agent: DENNISON ASSOCIATES

(54) Titre : ROBINET DE CHASSE A PISTON AVEC COUVERCLE INTERIEUR
(54) Title: PISTON-TYPE FLUSHOMETER WITH INNER COVER



(57) Abrégé/Abstract:

A flush valve includes a body having an inlet and an outlet. There is a main seat assembly at the outlet. An outer cover is attached to the body and an inner cover is attached to the body within the outer cover. A piston is movable within the body and inner cover and, with the inner cover, defines a pressure chamber. The piston carries an exterior seal which bears against an inside wall of the inner cover during movement of the piston. A refill orifice in the piston connects the chamber with the body inlet. Pressure in the chamber maintains the piston closed upon the main seat assembly. A relief valve is positioned in the piston for venting the chamber to the outlet. When the relief valve is opened and the chamber is vented, the piston moves away from the main seat assembly connecting the inlet with the outlet.

ABSTRACT

A flush valve includes a body having an inlet and an outlet. There is a main seat assembly at the outlet. An outer cover is attached to the body and an inner cover is attached to the body within the outer cover. A piston is movable within the body and inner cover and, with the inner cover, defines a pressure chamber. The piston carries an exterior seal which bears against an inside wall of the inner cover during movement of the piston. A refill orifice in the piston connects the chamber with the body inlet. Pressure in the chamber maintains the piston closed upon the main seat assembly. A relief valve is positioned in the piston for venting the chamber to the outlet. When the relief valve is opened and the chamber is vented, the piston moves away from the main seat assembly connecting the inlet with the outlet.

Sloan 1029-0367

**PISTON-TYPE FLUSHOMETER
WITH INNER COVER**

The Field of the Invention

[0001] The present invention relates to piston-type toilet flush valves and more specifically to an improvement in such flush valves in the form of an inner cover which insures better alignment between the piston and the cover to which it seals, resulting in more complete and accurate operation of the flush valve.

[0002] U.S. Patents 5,881,993 and 4,261,545, among other patents, all owned by Sloan Valve Company, show piston-operated flush valves for use in flushing toilets and urinals. In each of these patents the piston has an exterior seal which bears against the inside wall of the flush valve cover. The present invention adds an inside cover to the flush valve configuration, with the piston bearing against the inside cover which assures more accurate and reliable operation of the flush valve, as well as permitting the use of less expensive materials for certain components of the flush valve.

Summary of the Invention

[0003] The present invention relates to piston-operated flush valves for use in connection with toilets and urinals, and more specifically, to an improvement in the form of an inner cover, increasing the reliability of flush valve operation.

[0004] A primary purpose of the invention is a piston-type flush valve for the use described including an inner cover within which the piston moves during flush valve operation.

[0005] Another purpose of the invention is a flush valve as described in which the inner cover has centering ribs to insure appropriate alignment of the inner cover and flush valve body.

[0006] A further purpose of the invention is a flush valve as described in which the inner cover includes a reinforced projection functioning as a stop for the piston during its operation.

[0007] Yet another purpose of the invention is to provide a flush valve as described in which the inner cover is domed for increased strength and has radial ribs to strengthen the dome.

[0008] Still another purpose of the invention is a flush valve as described including an exterior ring on the inner cover which is engageable with the inside of the outer cover to limit expansion of the inner cover during pressure conditions.

[0009] Another purpose of the invention is a flush valve as described in which the inner cover allows for a renewable or replaceable sealing surface for engagement with the piston seal.

[0010] A still further purpose of the invention is a flush valve as described in which the inner cover allows for a more cost effective outer cover. The inner cover also ensures accurate water delivery and enables use of a standardized piston in variably-sized outer covers.

[0011] Another purpose of the invention is a flush valve as described in which the inner cover provides a gasket that isolates the outer cover threads from corrosive water and prevents leaking to the external environment.

[0012] These and other desired benefits of the invention, including combinations of features thereof, will become apparent from the following description. It will be understood, however, that a device could still appropriate the claimed invention without accomplishing each and every one of these desired benefits, including those gleaned from the following description. The appended claims, not these desired benefits, define the subject matter of the invention.

Brief Description of the Drawings

- [0013] Fig. 1 is a vertical section through a flush valve of the present invention.
- [0014] Fig. 2 is an enlarged partial section showing the connection between the flush valve body, the inner cover and the outer cover.
- [0015] Fig. 3 is an enlarged partial section illustrating the relationships among the valve body and its water passage, the main seat assembly, and the piston, with the actuator assembly and relief valve removed for clarity.
- [0016] Fig. 4 is a side elevation view of the inner cover.
- [0017] Fig. 5 is a bottom plan view of the inner cover.
- [0018] Fig. 6 is a section taken along line 6-6 of Fig. 5.
- [0019] Fig. 7 is an enlarged detail section of the flange and seal of the inner cover.
- [0020] Fig. 8 is a partial section taken along line 8-8 of Fig. 5.
- [0021] Fig. 9 is a top plan view of the main seat assembly.
- [0022] Fig. 10 is a section taken along line 10-10 of Fig. 9.
- [0023] Fig. 11 is an enlarged detail section of the sealing portion of the main seat assembly.
- [0024] Fig. 12 is a bottom plan view of the main seat assembly.
- [0025] Fig. 13 is a partial enlarged side elevation view of the main seat assembly showing one of the lockout lugs.
- [0026] Fig. 14 is a partial enlarged side elevation view of the main seat.
- [0027] Fig. 15 is a partial enlarged section of the main seat assembly showing an extension on one of the lockout lugs.

Description of the Preferred Embodiment

[0028] The present invention relates to improvements in piston-type flush valves such as those illustrated in U.S. Patents 4,261,545 and 5,881,993, both owned by Sloan Valve Company of Franklin Park, Illinois. The disclosures of both patents are incorporated by reference herein. Additional reference should be made to U.S. Patent 6,299,127, also owned by Sloan Valve Company, and illustrating a solenoid-operated flush valve. The invention will be described in connection with solenoid operation, but it is also equally adapted for manual handle operation as shown in the '545 and '993 patents. The disclosure of the '127 patent is incorporated by reference herein. When the flush valve shown herein is arranged for manual operation the water passage between the valve seat and the hydraulic actuator will be closed.

[0029] As illustrated in Figs. 1 - 3, the flush valve includes a body 10 having an upper interior thread 12 to which is threaded an outer cover 14. A decorative filler ring 16 may encircle the body 10 and outer cover 14 at the intersection of these two parts. The body 10 has an inlet 18 which will be connected to a suitable source of supply water and an outlet 20 which will be connected to either a toilet or a urinal.

[0030] Within the outer cover 14 there is an inner cover 22 which at its lower end has an outwardly extending flange 24. An undercut recess 26 (Fig. 2) is formed on the underside of the flange 24. The flange 24 rests upon an inwardly-directed ledge 28 of the body 10. The ledge has an internal axial surface 29. A seal 30 is positioned within the recess 26 to form an exterior seal for the flush valve body. The lower end 32 of the outer cover 14, after being connected to the body at the threads 12, will bear against the top of the flange 24 to lock the inner cover 22 firmly in position on the flush valve body and within the outer cover 14.

[0031] Focusing on Fig. 2, the inner cover 22 has a small radius 34 at the junction between the flange 24 and the cover which matches an outer radius 36 on the bottom of the end 32 of the outer cover 14 so as to provide stress relief at the junction between these two elements. Such radii reduce stress on the flange which might otherwise crack or gouge this portion of the inner cover.

[0032] Positioned within the body 10 and the inner cover 22 is a piston 40 which is urged toward a filtering main seat assembly 42. The main seat assembly is located between the inlet and outlet on a shoulder 44 of the valve body 10. The shoulder 44 has a radial top land and a cylindrical internal sealing wall 45. The piston 40 will be biased toward the main seat assembly 42 by water within a pressure chamber 46. Water passes into the chamber 46 from the inlet 18 through a refill orifice 48 in the side wall of the piston 40. The refill orifice is covered by an O-ring 50. Details of this structure are shown in the above-referenced 4,261,545 patent.

[0033] The interior of the piston 40 includes a seat 52 upon which rests a seal 53 and a relief valve 54. The relief valve is urged to this position by a spring 56 which bottoms, at its lower end, upon the relief valve 54, and at its upper end against a stop 58. The stop 58 is threaded into the top of the piston 40. The stop 58 has openings 60 through it which provide fluid communication between the refill orifice 48 and the pressure chamber 46.

[0034] The flush valve body 10 has an annulus 61 which defines an opening 62 in which an actuator assembly 64 is mounted. The actuator assembly will effect movement of the relief valve 54 in a manner described in the above-referenced patents. The actuator assembly 64 includes a solenoid 65 which can move a reciprocable plunger 72. The plunger normally closes a passage 74 which extends through the otherwise closed end of a cup 78. The cup is held in the opening

62 by a sleeve 71 which has a radial extension that engages the closed end of the cup. The sleeve 71 is clamped to the annulus 61 by a nut 73. The cup 78 defines a chamber 70 in which resides a reciprocable, fluid-driven piston/rod assembly 66. A spring 68 biases the piston/rod assembly 66 to the normal, retracted position shown in Fig. 1.

[0035] The sleeve 71 is sealed on its outer surface to the inner surface of the annulus 61 but the sleeve is not sealed on its inner surface to the cup 78. This permits water to flow between the sleeve and cup. Accordingly, the passage 74 in the end of the cup is in fluid communication with a hydraulic bypass 76 formed in the flush valve body. The bypass 76 receives water flowing from the inlet 18 through the filtering main seat assembly 42 as described hereinafter. Under normal conditions, water will leak between the exterior of the cup 78 and the interior of the sleeve 71 and be directly adjacent the passage 74. When the solenoid 65 is activated it pulls its plunger 72 away from passage 74. Water which has passed around the cup 78 will flow through the passage 74, causing the piston/rod assembly 66 to move against the force of spring 68 and tilt the relief valve 54. Tilting of the relief valve vents pressure within chamber 46 to the outlet 20. Water pressure at the inlet 18 acting on the piston 40 is then no longer counterbalanced by pressure within chamber 46 so the inlet pressure causes the piston to rise off of the main seat assembly 42. This provides an uninterrupted fluid path between the inlet 18 and the outlet 20. As water flows through the refill orifice 48, pressure in chamber 46 is reestablished, which gradually forces the piston back down on the main seat assembly, thereby reclosing the valve. The operation, as described, is more fully disclosed in the above-mentioned U.S. patents owned by Sloan Valve Company.

[0036] The inner cover 22 is more specifically shown in Figs. 4 - 8. The inner cover includes

the aforementioned outwardly-extending flange 24, beneath which are a plurality of outwardly-extending axial ribs 82 which extend from a peripheral wall 84. The ribs 82 engage the axial surface 29 of the inwardly-directed ledge 28 to center the cover 22 within the body 10. This in turn centers the internal wall of the inner cover with the attendant sealing benefit described below.

[0037] As illustrated, the top 86 of the inner cover is domed, providing additional strength to resist the pressure within chamber 46. At the center of the dome 86 there is an outwardly-extending ring 88 which, as shown in Fig. 1, is in contact with the inside of the outer cover 14. There is a controlled clearance between the top of ring 88 and the inside surface of the outer cover to insure the maximum clamp load is directly applied to the seal 30 at the inwardly-directed ledge 28. As pressure increases to a sufficient amount, well above 100 psi, the inside cover will expand to contact the outer cover which will then limit further expansion.

[0038] The interior surface of the inner cover's top 86 has a downwardly-extending annular projection 90. This projection functions as a stop to limit upward movement of the piston 40. The stop 58 on the piston 40 will move upwardly during operation, but the piston's upward movement will be limited by the projection 90. The stroke of the piston assists in determining the duration of time during which the flush valve will provide a fluid connection between the inlet and the outlet. The ring 90 is reinforced by a plurality of radial ribs 92 shown particularly in Figs. 5 and 8.

[0039] As best seen in Fig. 2 the piston 40 has a seal 94 which is carried by the piston and which bears against the inside wall 96 of the inner cover 22. This seal establishes the pressure chamber 46. The seal will move against the inside wall 96 as the piston moves between the open

and closed positions during flush valve operation.

[0040] One of the advantages of the inner cover as described and shown herein is that it isolates the outer cover from water contact, allowing the outer cover to be made of a less expensive material. Further, the ribs 82 improve alignment of the piston and piston seal within the flush valve body, thereby improving reliability of the valve. An additional advantage is that the seal between the valve body 10 and the cover may be easily renewed by replacing the inner cover.

[0041] It is preferred that the inner surface of the inner cover wall 96 have a degree of texture. The surface should not be so smooth that the lip seal of the piston will stick and act erratically, nor can it be so rough as to not provide for a complete seal between the piston and the inner cover. It is preferred that the finish on the inner cover have a surface roughness in the range of about 8 microinches to about 32 microinches.

[0042] Figs. 3 and 9 - 15 illustrate in detail the filtering main seat assembly 42. The main seat assembly is located between the inlet 18 and the outlet 20. Its principal functions are to form a semi-dynamic closing seal with the piston 40, to form a static seal with the valve body, to guide the piston during its operation, and to filter inlet water going into the bypass 76 for hydraulic assist with the actuator assembly. The main seat assembly 42 has two primary components, a main seat filter 98 and a sealing surface 100. Preferably the sealing surface 100 is molded directly in place on the main seat filter 98. The sealing surface 100 is engageable with a radial surface 102 (Fig. 3) of the piston to form the semi-dynamic seal between the piston 40 and the main seat assembly 42. The piston also has a skirt 101 which centers the piston in the main filter seat.

[0043] The main seat filter 98 is made of a material that is relatively rigid compared to the material of the sealing surface 100. By way of example only, the main seat filter may be made of polypropylene which is 30% glass filled, while the sealing surface may be made of a synthetic elastomer, such as that sold by Advanced Elastomer Systems, under their trademark Santoprene®. It will be realized that other suitable materials could be used.

[0044] The main seat filter 98 includes an annular ring portion 103 that defines a central opening 105. The main seat filter also has a lower, cylindrical portion 106 that extends downwardly from the ring 103. An undercut notch 107 (Figs. 10 and 14) at the bottom of the cylindrical portion 106 receives an O-ring 104 (Fig. 3) which forms a static seal with the internal sealing wall 45 of the valve body shoulder 44 to eliminate leakage at this point in the valve body. The ring 103 has a plurality of v-notches or grooves 108 at its periphery which are directly adjacent the valve body portion 110 (Fig. 3). Together the grooves 108 and body portion 110 define a plurality of small, filter-like passages whose collective total flow area is larger than that of the flow area defined by plunger 72 when activated and passage 74. As shown herein, there may be twenty-four such filtering grooves 108, although that exact number is not essential to the invention. The grooves 108 are positioned such that as the valve cycles, the inrush of water will wash away any large debris which may have accumulated in the grooves 108, further reducing the chances of the filter passages becoming blocked.

[0045] The main seat filter 98 also contains a plurality of landing pads 114 on a lower surface 116 of the ring 103. The pads function as a positive stop when installing the seat onto the top land of the valve body's shoulder 44. The pads further cooperate with the portion 110 of the valve body to define a flow passage about the periphery of the ring 103 of the main seat filter 98.

This flow passage connects the bypass 76 with the inlet supply water so that the flush valve may function correctly when the solenoid is operated.

[0046] It can be seen that the bypass 76 is downstream of the filter formed by the ring 103 and its grooves 108, but the bypass is upstream of the seal 104. Thus, inlet water can go through the filter and bypass 76 to get to the actuator assembly 64, but inlet water cannot get around the main seat assembly to the outlet 20, except when the valve is intentionally activated.

[0047] It has been found advantageous to form the hydraulic bypass 76 by casting it in place in the valve body 10. This avoids the need for a secondary drilling operation during manufacture of the valve body. Furthermore, the bypass 76 should be arranged such that it does not intersect with the sealing wall 45 of the shoulder 44. By spacing the bypass from the shoulder, well outside of any sealing areas, the potential for damage to the main seat assembly's seal ring 104 during installation is avoided. That is, because the bypass does not open in the area of the sealing wall 45, it cannot present any sharp edges or burrs that could otherwise have the potential to cut or damage the seal ring as the ring is moved past the bypass during installation.

[0048] Figs. 9 - 15 illustrate further details of the main seat assembly 42. The ring 103 and sealing surface 100 have a geometry specifically tailored for this application. The shape of the sealing surface cooperates with that of the ring to provide the desired performance. Specifically, the upper surface of the ring 103 has an upstanding sill 118 about its periphery. The grooves 108 are formed at the outer edge of the sill. The inner edge of the sill forms a first axial wall 120. The upper surface of the ring 103 further includes an upstanding rib 122 which is generally trapezoidal in cross section. That is, the top edge of the rib does not form a sharp point but rather is shaved off slightly to form a radial top edge. The rib has a second axial wall 124. Together

the first and second axial walls 120, 124 define a channel on top of the ring 103. A majority of the sealing surface 100 is disposed within the channel. It is important that the sealing surface be bounded by the axial walls so that deformation of the sealing surface in a radial direction is limited.

[0049] The upper face of the sealing surface 100 includes a flat base 126 and an upstanding, arcuate crown 128. The crown is radially inward of the base. This profile provides a higher initial sealing stress by creating a line contact with the radial surface 102 on the piston. Thus, a seal will be created at even the lowest of water pressures. This profile also maintains a high spring constant which limits compression of the sealing surface. As the water pressure increases the crown 128 will deform slightly which increases the sealing area on the piston. But due to the constraints in the geometry, the sealing area will never exceed a desired limit. Even if the crown were to flatten out completely, the contact area will be less than in prior seals, thereby maintaining the desired high seal stress, and the seat will be compressed less than prior designs, thereby allowing more consistent flushing. The compression of the sealing surface is limited by the mechanical stiffness of the elastomeric material and the area free to expand. The area free to expand is governed by the sealing surface's geometry and that of the ring 103. Specifically, the first and second axial walls 120, 124 define the channel in which the base 126 of the seal resides. These walls limit the area of the sealing surface that is free to expand. Another advantage of the crown 128 and thickness of the base 126 is it counteracts the tendency of the sealing surface material to take a set after it has been under compression.

[0050] By way of example only and not by way of limitation, an acceptable profile of the sealing surface 100 has been made with the following approximate dimensions. The diameter of

the first axial wall 120 is about 1.43 inches. The height of the axial wall, and thus the thickness of the base 126, is about .045 inches. The diameter of the second axial wall 124 is about 1.06 inches while its height is .025 inches. The curvature of the crown 128 has a radius of about .25 inches.

[0051] The base portion 126 of the sealing surface is interrupted by a set of raised lockout lugs 130. As seen in Fig. 15, the lugs have a height greater than that of the crown 128. The height of the lugs, together with the diameter of the base 126 on which they are located, causes the lugs to interfere with the seating of older pistons on the sealing surface. The older style pistons have a ring that will contact the lugs and prevent the such pistons from closing the valve. Such older style pistons are not to be used because they allow more water per flush than permitted by current codes. However, the lugs 130 will not interfere with the correctly-sized piston 40. The radial surface 102 of piston 40 has a diameter that allows it to fit inside of the lugs 130 and in engagement with the crown 128 of the sealing surface. The lugs 130 are molded into the sealing surface in such a manner that if one attempted to remove them it would very likely lead to destruction of the critical sealing surface. The lugs are shaped to create a minimal flow restriction when the piston is unseated. One of the lugs has an extension 132 that will partially cover the bypass 76. This extension forces the water to be filtered by the v-notches or grooves 108.

[0052] It will be noted that the structure described provides for precise alignment of the piston's dynamic seal 94 with the inside wall 96 of the inner cover. This alignment is ultimately dependent on the axial sealing wall 45 and the axial surface 29 of the ledge 28 being concentric. These surfaces are carefully controlled during manufacture of the body to be concentric. The

lower cylindrical portion 106 of the main seat assembly 42 will then fit inside the wall 45 and assure alignment of the opening 105. The piston skirt 101 guides the piston in the opening 105 to precisely locate the seal 94. Similarly, the centering ribs 82 on the cover will fit inside the axial surface of the ledge 28 to precisely locate the inside wall 96 of the inner cover 22.

[0053] While the preferred form of the invention has been shown and described herein, it should be realized that there may be many modifications, substitutions and alterations thereto. For example, if a conventional, manually-operated handle were installed instead of the solenoid-operated actuator 64, the bypass 76 may be plugged.

I CLAIM:

1. A flush valve including a body having an inlet and an outlet, a main seat assembly at said outlet, an outer cover attached to the body, an inner cover attached to the body within the outer cover, a piston movable within the body and inner cover, the piston and the inner cover defining a pressure chamber, an exterior seal carried by the piston and bearing against an inside wall of the inner cover during movement of the piston, a refill orifice in the piston connecting the pressure chamber with the body inlet, pressure in the pressure chamber maintaining the piston closed upon the main seat assembly, a relief valve in the piston for venting the pressure chamber to the outlet, and an actuator mounted in the body and selectably engageable with the relief valve to vent the pressure chamber causing the piston to move away from the main seat assembly.

2. The flush valve of claim 1 wherein the inner cover rests on a portion of the body and is held thereon by the outer cover.

3. The flush valve of claim 2 wherein the inner cover has a plurality of exterior centering ribs on a portion thereof, which ribs engage an inside surface of the body.

4. The flush valve of claim 2 wherein the portion of the body upon which the inner cover rests is an inwardly-directed ledge, the inner cover having an outwardly-directed flange which rests upon the inwardly-directed ledge of the body.

5. The flush valve of claim 4 further including a peripheral seal between an underside of

the flange of the inner cover and an upper side of the ledge of the body to form a seal between the inner cover and the body.

6. The flush valve of claim 5 further including a recess in the underside of the flange of the inner cover, said peripheral seal being positioned within the recess.

7. The flush valve of claim 5 wherein the outer cover has a portion thereof clamping downwardly on an upper side of the inner cover's outwardly-directed flange.

8. The flush valve of claim 1 further including a projection on an inside surface of the inner cover, the projection being engageable with the piston to limit upward movement of the piston.

9. The flush valve of claim 8 wherein the inner cover includes a top, the top including a ring extending from the top toward the outer cover.

10. The flush valve of claim 8 wherein the inside surface of the inner cover further comprises a plurality of reinforcing ribs.

11. The flush valve of claim 9 wherein the inner cover top is domed.

12. The flush valve of claim 1 wherein the inner cover has a top, the top being domed,

and the top having a ring directed toward the inside of the outer cover to limit movement of the inner cover during pressure conditions in the pressure chamber.

13. The flush valve of claim 12 wherein the ring is annular.

14. The flush valve of claim 1 wherein the inner cover has an inner surface with a surface texture of on the order of about 8 microinches to about 32 microinches.

15. A flush valve including a body having an inlet and an outlet, a main seat assembly at the outlet, an outer cover attached to the body by threads, an inner cover attached to the body within the outer cover and in sealing engagement with the body to isolate the outer cover threads from contact with water, a piston movable within the body and inner cover, the piston and the inner cover defining a pressure chamber, an exterior seal carried by the piston and bearing against an inside wall of the inner cover during movement of the piston, a refill orifice in the piston connecting the pressure chamber with the body inlet, pressure in the pressure chamber maintaining the piston closed upon the main seat assembly, a relief valve in the piston for venting the pressure chamber to the outlet, and an actuator mounted in the body and selectably engageable with the relief valve to vent the pressure chamber causing the piston to move away from the main seat assembly.

16. The flush valve of claim 15 wherein the body includes an inwardly-directed ledge and the inner cover includes an outwardly-directed flange which rests upon the inwardly-directed

ledge of the body.

17. The flush valve of claim 16 further including a peripheral seal between an underside of the flange of the inner cover and an upper side of the ledge of the body to form said sealing engagement between the inner cover and the body.

18. The flush valve of claim 17 further including a recess in the underside of the flange of the inner cover, said peripheral seal being positioned within the recess.

19. The flush valve of claim 17 wherein the outer cover has a portion thereof clamping downwardly on an upper side of the inner cover's outwardly-directed flange.

20. The flush valve of claim 15 further including a projection on an inside surface of the inner cover, the projection being engageable with the piston to limit upward movement of the piston.

21. The flush valve of claim 20 wherein the inner cover includes a top, the top including a ring extending from the top toward the outer cover.

22. The flush valve of claim 20 wherein the inside surface of the inner cover further comprises a plurality of reinforcing ribs.

23. The flush valve of claim 21 wherein the inner cover top is domed.

24. The flush valve of claim 15 wherein the inner cover has a top, the top being domed, and the top having a ring directed toward the inside of the outer cover to limit movement of the inner cover during pressure conditions in the pressure chamber.

25. The flush valve of claim 24 wherein the ring is annular.

26. The flush valve of claim 15 wherein the inner cover has an inner surface with a surface texture of on the order of about 8 microinches to about 32 microinches.

27. A flush valve including a body having an inlet and an outlet, a main seat assembly at said outlet, the main seat assembly having a cylindrical portion which engages an inside surface of the body to center an opening of the main seat assembly, an outer cover attached to the body, an inner cover attached to the body within the outer cover, the inner cover having a plurality of exterior centering ribs on a portion thereof, which ribs engage an inside axial surface of the body to center an inside wall of the inner cover, a piston movable within the body and inner cover, the piston having a skirt engageable within the main seat assembly opening to center the piston, the piston and the inner cover defining a pressure chamber, an exterior seal carried by the piston and bearing against said inside wall of the inner cover during movement of the piston, a refill orifice in the piston connecting the pressure chamber with the body inlet, pressure in the pressure chamber maintaining the piston closed upon the main seat assembly, a relief valve in the piston

for venting the pressure chamber to the outlet, and an actuator mounted in the body and selectably engageable with the relief valve to vent the pressure chamber causing the piston to move away from the main seat assembly.

28. The flush valve of claim 27 wherein the inner cover rests on a portion of the body and is held thereon by the outer cover.

29. The flush valve of claim 28 wherein the portion of the body upon which the inner cover rests is an inwardly-directed ledge, the inner cover having an outwardly-directed flange which rests upon the inwardly-directed ledge of the body.

30. The flush valve of claim 29 further including a peripheral seal between an underside of the flange of the inner cover and an upper side of the ledge of the body to form a seal between the inner cover and the body.

31. The flush valve of claim 30 further including a recess in the underside of the flange of the inner cover, said peripheral seal being positioned within the recess.

32. The flush valve of claim 30 wherein the outer cover has a portion thereof clamping downwardly on an upper side of the inner cover's outwardly-directed flange.

+

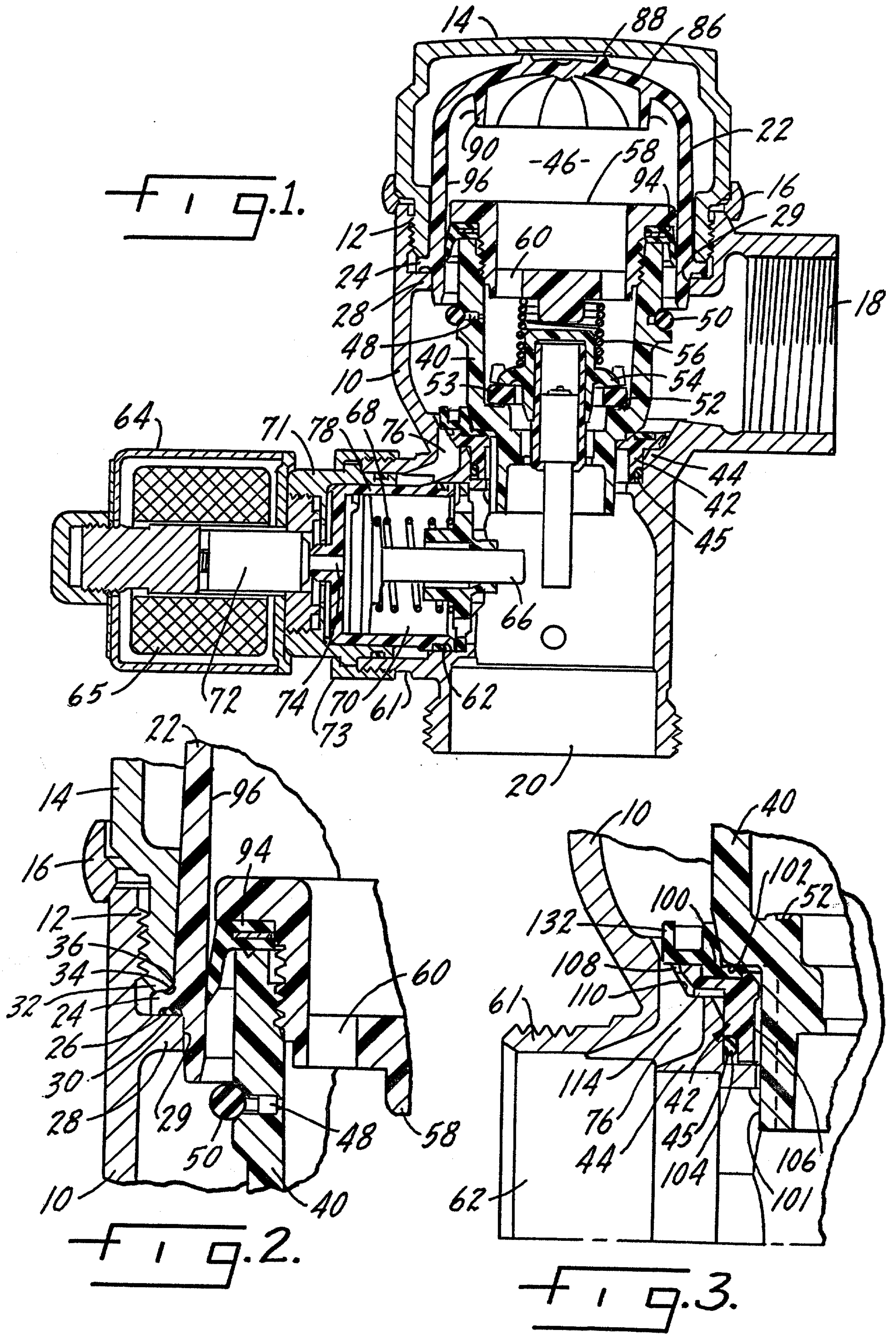

+

+

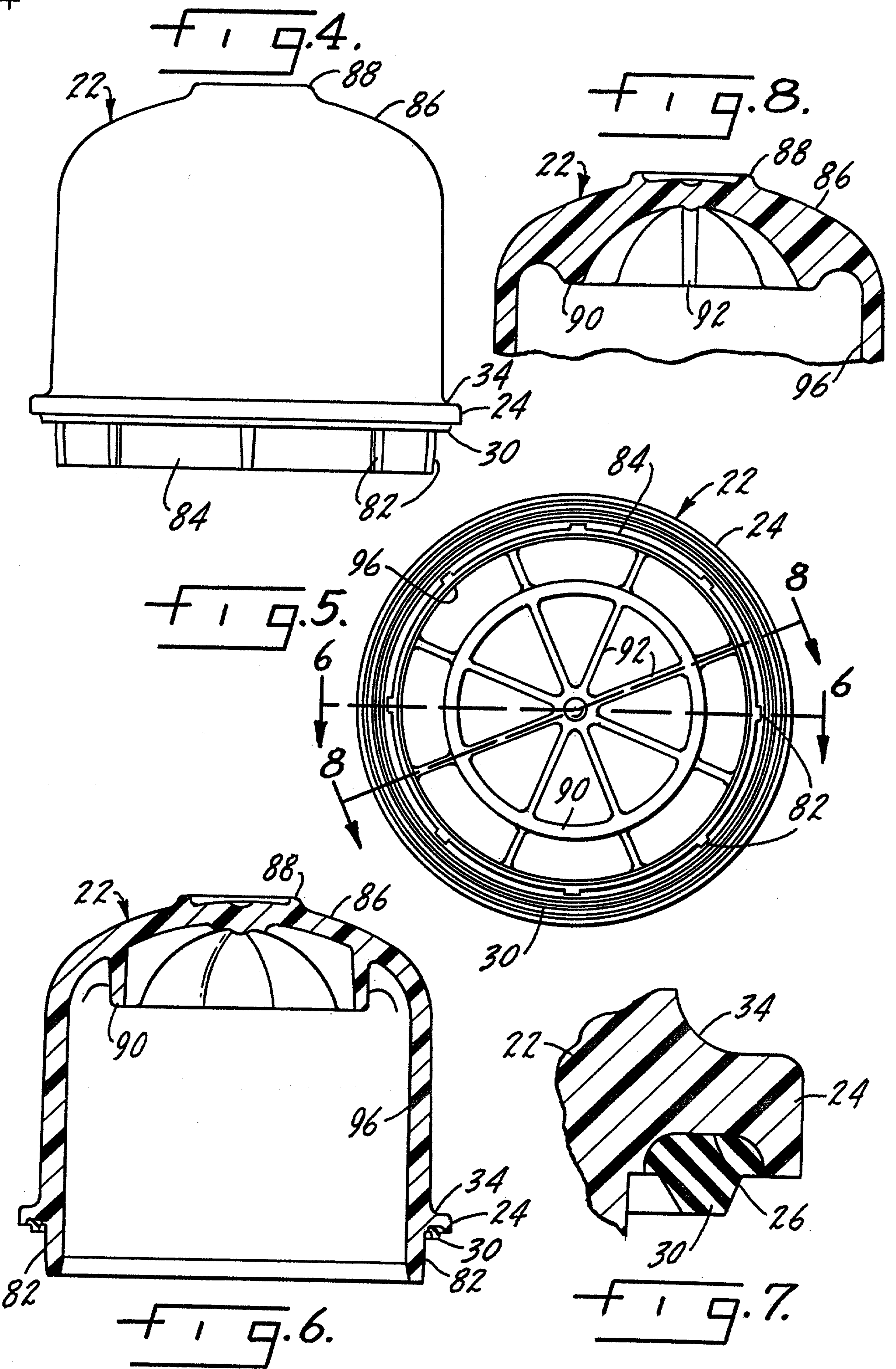

+

+

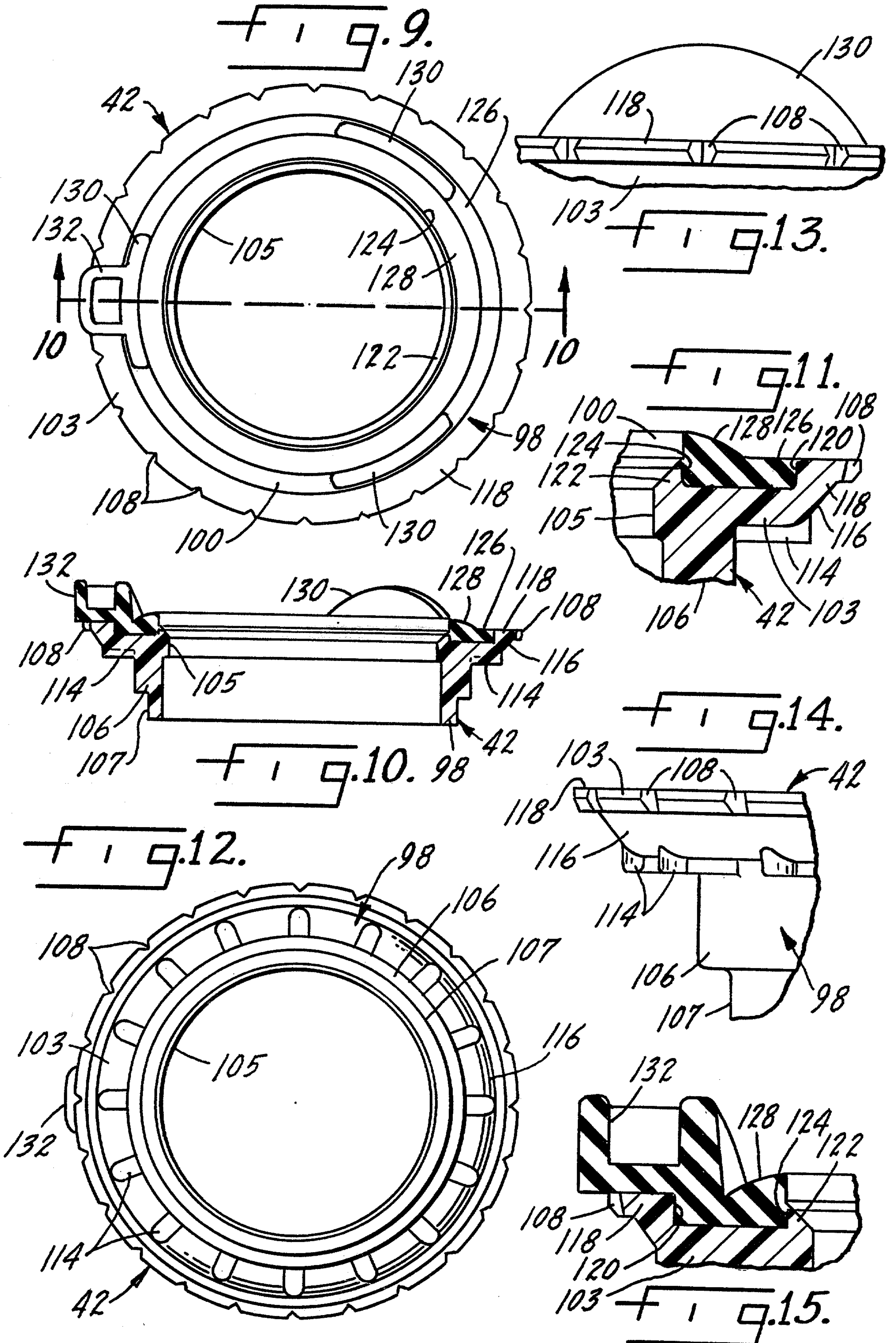

+

