



Europäisches Patentamt  
European Patent Office  
Office européen des brevets



Publication number: **0 533 064 B1**

12

## EUROPEAN PATENT SPECIFICATION

- 49 Date of publication of patent specification: **15.11.95** 51 Int. Cl.<sup>8</sup>: **B26F 1/40, A63F 9/00**
- 21 Application number: **92115555.2**
- 22 Date of filing: **11.09.92**

54 **Manufacture of jigsaw puzzles.**

30 Priority: **20.09.91 GB 9120087**

43 Date of publication of application:  
**24.03.93 Bulletin 93/12**

45 Publication of the grant of the patent:  
**15.11.95 Bulletin 95/46**

84 Designated Contracting States:  
**DE FR GB IT**

56 References cited:  
**DE-A- 3 303 882**  
**FR-A- 2 385 420**  
**FR-A- 2 443 386**  
**FR-A- 2 653 350**  
**US-A- 5 019 314**

73 Proprietor: **SAMCO-STRONG LIMITED**  
**P.O. Box 129**  
**Ross Walk**  
**Belgrave**  
**Leicester LE4 5BY (GB)**

72 Inventor: **Cooper, Kenneth Charles**  
**4 Strathglen Close**  
**Kimberley,**  
**Nottingham NG1 6LX (GB)**

74 Representative: **Atkinson, Eric**  
**c/o USM TEXON LTD**  
**Patent & Legal Department**  
**P.O. Box 88**  
**Ross Walk**  
**Belgrave**  
**Leicester LE4 5BX (GB)**

**EP 0 533 064 B1**

Note: Within nine months from the publication of the mention of the grant of the European patent, any person may give notice to the European Patent Office of opposition to the European patent granted. Notice of opposition shall be filed in a written reasoned statement. It shall not be deemed to have been filed until the opposition fee has been paid (Art. 99(1) European patent convention).

## Description

This invention is concerned with a method of manufacturing jigsaw puzzles wherein interlocking pieces thereof are cut out from a single sheet of material, a punch-and-die assembly for carrying out such method, and jigsaw puzzles made using such a method.

### Background Art

In the manufacture of jigsaw puzzles it is usually the case that a cutting die is used of the type comprising a steel cutting blade which is formed to a desired configuration and is set in a wooden base, suitable ejectors, in the form of pads of resilient material, being arranged at opposite sides of the blade. Using such a die, moreover, especially when cutting large area jigsaw puzzles, customarily one such die is provided for effecting the cutting operation in one direction and a separate die is used for cutting in a direction perpendicular to the first-mentioned direction. In this way initially the material from which the jigsaw is to be cut is in fact cut into lengths and in the second cutting operation these lengths are then cut into the individual pieces.

This approach is advantageous in that the cutting pressure required for effecting each of the two cutting operations is substantially less than if a single cutting operation were effected for the complete puzzle, but this approach does not give rise to the risk that, because some work handling has to be effected between the two cutting operations, one strip of material may become detached from the remainder during such work handling, quite apart from the fact that two cutting operations are time-consuming and thus increase the overall cost of manufacture.

In cutting jigsaw puzzles in this manner, conventionally so-called toggle presses have been used which comprise a steel cutting table between which and an upper platen relative movement of approach can take place under close control in order to ensure on the one hand that the material to be cut is cut through cleanly while on the other hand the blade of the cutting die is protected from being blunted by being pressed with too great a force against the steel cutting table. Using a cutting die as described above, it is usually the case that a good deal of so-called make-ready is required, i.e. localised variation in the depth of the cutting die in order to ensure that the material is in fact cleanly cut but without damage to the cutting blade. In some instances such make-ready will require up to three or even four days by a skilled workman in the case of a large jigsaw. It will of course be appreciated that such use of a workman's time signifi-

cantly increases the cost of tooling for a jigsaw puzzle.

A further disadvantage in using a cutting die of the aforementioned type is that the cut edges of the jigsaw pieces tend to be rounded at the surface which is penetrated by the cutting die, while there may be some tendency for burrs to be formed at the opposite surface. The rounding of the cut edges as aforesaid tends to be highlighted when the jigsaw puzzle is assembled by the puzzler, which may be detrimental to the appearance of the finished puzzle. Moreover, if it is desired to have a double-sided jigsaw puzzle, firstly it is quite apparent to the puzzler which way up each piece must be, since the surfaces have a quite different appearance, while secondly it is quite difficult to assemble the puzzle when attempting the puzzle on the reverse, i.e. non-rounded, surface. Unless, therefore, further work is carried out on the pieces, a jigsaw cut using a conventional cutting die cannot readily be assembled by a puzzler.

### The Invention

It is thus one of the various objects of the present invention to provide an improved method of manufacturing jigsaw puzzles wherein the above disadvantages are avoided.

The invention thus provides, in one of its several aspects, a method of manufacturing jigsaw puzzles wherein interlocking pieces thereof are cut out from a single sheet of material in a single cutting stroke, characterised by using a punch-and-die assembly comprising upper and lower tools with cooperating lands and apertures, wherein adjacent pieces of the puzzle are cut out one by a land of the upper tool and a cooperating aperture of the lower tool and the other by a land of the lower tool and a cooperating aperture of the upper tool, the apertures of each tool being defined by the lands of that tool.

It is of course acknowledged that punch-and-die assemblies are well known in the metal-working industry, but in general they are not used in applications where the whole of the material which is "cut" thereby is then used, e.g. in the case of a jigsaw puzzle; rather, punch-and-die assemblies tend to be used in conditions where a workpiece is to be "cut" from a sheet of material, and thereafter the unwanted remnants of material, i.e. the scrap, must be separated from the cut piece and removed.

Moreover, using a punch-and-die assembly for the manufacture of jigsaw puzzles produces significant benefits in terms firstly of enabling a complete puzzle to be manufactured in a single cutting operation, thereby not only reducing the time required for its manufacture but avoiding the risk of loss or

dislodgement of any sections thereof during any work handling, and secondly of the elimination of any requirement for the use of make-ready and the consequent imposition on the time of an operator in this regard. Moreover, the "cut" achieved using a punch-and-die assembly is essentially straight-sided so that there is no rounding effect on one surface and no risk of burrs on the other and moreover the two surfaces have the same appearance and the cut edges on both surfaces have the same configuration so that the puzzle can be assembled from either side and double-sided puzzles can thus readily be produced without the puzzler being able to deduce from the shape of the cut edges which way up any particular piece should be.

As is conventional in punch-and-die assemblies used for metal-working, moreover, each aperture of the upper and lower tools has an ejector piece therein which is urged by resilient means to an advanced position, in which its surface is flush with the surface of the lands adjacent thereto. In the case of the upper tool the resilient means may be in the form of a pad of resilient material, e.g. synthetic rubber, against which each ejector piece, or a rearward projection thereof, is pressed during the cutting operation and thus by which, following the cutting operation, the ejector piece is returned to its "flush" condition, while in the lower tool preferably a hydraulic or pneumatic cushion is provided, again acting similarly on the rearward portion or a projection thereof of each ejector piece.

The hydraulic or pneumatic cushion, moreover, provides a counter-pressure during the closing together of the upper and lower tools, and this counter-pressure is found to be beneficial in preventing a splitting of the material being cut during the cutting operation, so that a clean shear can be achieved.

In carrying out the method in accordance with the invention, moreover, any suitable material from which jigsaw puzzles are currently made may be used, e.g. cardboard and plywood. Moreover, because of the application of the counter-pressure, other materials may now be contemplated for use in the manufacture of jigsaw puzzles, which materials previously could not have been used because e.g. of a tendency to shatter when pressure is applied thereto through a cutting die.

The punch-and-die assembly used in carrying out the method in accordance with the present invention may be conventionally manufactured using known wire erosion techniques. It has been found that using a wire having a diameter of 0.1mm (0.004") produces an assembly by which a jigsaw puzzle having closely fitting pieces can be manufactured.

The invention thus further provides, in another of its several aspects, a punch-and-die assembly for cutting out jigsaw puzzles, characterised by upper and lower tools with cooperating lands and apertures so arranged, that the lands of each tool are spaced from one another by the apertures located therebetween, the apertures of the upper tool corresponding with the lands of the lower tool and vice versa, so that, when the assembly is in use, adjacent pieces of the jigsaw puzzle are cut out one by a land of the upper tool and a cooperating aperture of the lower tool and the other by a land of the lower tool and a cooperating aperture of the upper tool.

Further advantages which are achieved in the manufacture of jigsaw puzzles using the method in accordance with the present invention and indeed using a punch-and-die assembly in accordance with the invention for such method reside firstly in that substantially lower pressure need now be applied than is the case when using cutting dies in a conventional manner, and secondly the restrictions imposed by the use of a cutting die comprising a blade in terms of the configuration of the individual pieces, in particular because of the difficulties of bending the blade especially to small radii, are now eliminated, subject only to, where a wire eroding technique is used, the diameter of the wire, which of course in general will not affect the desired shapes in any way.

The invention further provides, in yet another of its several aspects, a jigsaw puzzle characterised in that the pieces of the puzzle are cut out using a method as set out above. Such a jigsaw puzzle exhibits the various features referred to above, in particular cleanly cut edges and the ability of its individual pieces to be interlocked from either surface, which latter feature enables double-sided jigsaw puzzles to be readily produced as easily as single-sided ones.

#### The Drawings

Figure 1 is an exploded perspective view of a punch-and-die assembly in accordance with the invention, comprising upper and lower tools;

Figure 2 is a fragmentary section view through the assembly shown in Figure 1; and

Figure 3 is a view in side elevation of a piece of a jigsaw manufactured carrying out the method in accordance with the invention using the assembly of Figures 1 and 2.

#### Best Mode

The punch-and-die assembly shown in Figures 1 and 2 is designed for use in a conventional hydraulic beam press, the assembly being a sepa-

rate unit which can be placed between the platens of such press. The invention is however more broadly applicable, and it will be appreciated that alternative versions of the punch-and-die assembly may be designed which nevertheless will fall within this scope of the invention as defined by the claims.

The punch-and-die assembly shown in Figures 1 and 2 comprises an upper tool 10 and a lower tool 12. Each of the tools 10,12 comprises a frame 14 mounted on a bolster 16 which in turn is carried on a base plate 18. Accommodated within the frame 14 of each tool 10,12 and secured to the bolster 16 thereof are a plurality of lands 20, each of the lands 20 acting as a punch, with the arrangement being such that the lands 20 of the upper tool 10 are spaced from one another by apertures 22 which correspond with the lands 20 of the lower tool 12, and vice versa. Conveniently, the lands 20 of both tools are cut from a single sheet of metal, e.g. tool steel; one suitable cutting process is constituted by a wire erosion technique using a wire of 0.1mm diameter (0.004"). Moreover, by angling the wire during the machining process the clearance between the lands 20 when properly located on their respective bolsters 16 is minimal. In each of the apertures 22, moreover, is accommodated a correspondingly shaped ejector piece 24; conveniently the ejector pieces 24 for the two tools 10,12 are also cut from a single sheet of tool steel, using a wire erosion technique as in the case of the lands 20. Each ejector piece 24 is supported by a rearwardly projecting pin 26 having a rearward enlarged head 28 accommodated in a bush 30, itself accommodated in a suitable bore formed therefor in the bolster 16 and base plate 18. Each pin 26 carries a spring 32 which acts between the rearward face of the ejector piece 24 and the bottom of the aperture 22 to urge the ejector piece 24 into a condition in which its surface lies flush with the surface of its adjacent lands 20, this position of each ejector piece 24 being determined by engagement of the enlarged head 28 with the forward end of its bush 30. If desired, furthermore, the bush 30 may be filled with a compressible rubber block which assists the spring 32 in maintaining the ejector piece 24 in its flush condition. In case a cut piece becomes lodged in one of the apertures 22, furthermore, a bore 34, being a continuation, of reduced diameter, of the bore accommodating the bush 30 in the base plate 18, is provided thus to provide access to the rearward side of the head 28.

For ensuring the correct register of the upper and lower tools 10,12 and thus of the respective lands 20 thereof, the base plate 18 of the lower tool 12 is provided with four location pins 36, one at each corner, which pins 36 engage in location apertures 38 formed in the base plate 18 of the

upper tool 10. Moreover, the pins 36 are each provided with a compression spring 40 by which the upper and lower tools 10,12 are urged apart, the springs 40 being of course compressible to allow closure of the punch-and-die assembly during a cutting operation.

It will be appreciated that a punch-and-die assembly as above described is generally of the same construction as conventional assemblies, but in this case each land 20 serves to punch out a part of the finished workpiece, viz. a jigsaw puzzle, as opposed to the conventional use of such assemblies where it is more a matter of punching out desired pieces while the remainder of the sheet material is scrap.

In other assemblies in accordance with the invention, the base plates 18 of the tools 10,12 may be dispensed with and the bolster 16 of each tool 10,12 be directly attached to a platen of the press, in which case the bushes 30 would be relatively shallow and the heads 28 of the pins 26 would lie flush with the rear face of the bolster 16 when the ejector piece 24 is in its flush condition, a pad of compressible rubber being interposed between the rear face of the bolster 16 and the press platen. Moreover, especially in the case of the lower tool 12, instead of a pad of compressible material a so-called hydraulic or pneumatic die cushion may be provided; this is of conventional construction and comprises pins or the like which would then engage with the rear faces of the heads 28. The advantage of using such a die cushion will be discussed hereinafter.

In using a punch-and-die assembly as described above in carrying out the method in accordance with the invention a piece of cardboard or plywood having a desired illustration on one or both sides and being of the same external dimension as the internal dimension of the frame 14 is placed in the assembly in alignment with the surface of the lower tool 12 provided by the lands 20 and ejector pieces 24 thereof such that the piece does not overlap the frame 14. The assembly is then placed between the platens of a beam press and the latter are closed thus firstly to compress the piece of material between the surfaces provided by the lands 20 and the ejector pieces 24. Continued application of pressure thereafter is then effective to cause the material to be cut between the cooperating lands 20 of the upper and lower tools 10,12, the cooperating ejector pieces 24 being retracted into their apertures 22 accordingly. By reason of a counter-pressure applied through the ejector pieces 24 under the action of the rubber blocks in the bushes 30, a controlled cutting pressure can thus be applied to the piece of material being cut, with the effect that a clean straight-sided cut is achieved in each case. When, furthermore, a

hydraulic or pneumatic die cushion as above referred to is used, the control of this counter-pressure is significantly enhanced. In carrying out the method in accordance with the invention it has been found that a significant reduction in the applied pressure as compared with a conventional cutting die is required; in practice, it is expected that only half the pressure required for use with a cutting die will be required in the case of the use of a punch-and-die assembly in accordance with the invention, for cutting a workpiece of the same dimensions.

The punch-and-die assembly shown in Figures 1 and 2 is relatively small being an assembly by which a jigsaw puzzle of some 48 pieces is to be manufactured, but clearly the principle can be applied to the manufacture of jigsaw puzzles of all conventional sizes which can be cut by a cutting die; that is to say, up to 3,000 pieces. Moreover, in comparison with the cutting operation using the punch-and-die assembly in accordance with the invention cuts the whole puzzle in a single cutting operation, as compared with the two-stage cutting process conventionally practised when using cutting dies.

As can be seen from figure 3, jigsaw puzzles made using the aforementioned method and assembly demonstrate sharp cut edges and straight sides of cut without burrs or fractures, and in this way it is possible to assembly a jigsaw puzzle made using this method from either side, thereby facilitating the manufacture of double-sided jigsaw puzzles.

### Claims

1. Method of manufacturing jigsaw puzzles wherein interlocking pieces thereof are cut out from a single sheet of material in a single cutting stroke, characterised by using a punch-and-die assembly comprising upper and lower tools (10,12) with cooperating lands (20) and apertures (22), wherein adjacent pieces of the puzzle are cut out one by a land (20) of the upper tool (10) and a cooperating aperture (22) of the lower tool (12) and the other by a land (20) of the lower tool (12) and a cooperating aperture (22) of the upper tool (10), the apertures (22) of each tool being defined by the lands (20) of that tool.
2. Method according to Claim 1 wherein the sheet of material from which the interlocking pieces are cut out is of cardboard having a picture on at least one side.
3. Method according to Claim 1 wherein the sheet material from which the interlocking

pieces are cut out is of plywood having a picture on at least one side.

4. Method according to any one of the preceding Claims wherein ejector pieces (24) are accommodated in the apertures (22) of each tool (10,12) and are resiliently urged into a condition in which their workpiece-contacting surfaces are flush with those of the adjacent lands (20), and further wherein, as the upper and lower tools (10,12) are urged together in a cutting operation, a counter-pressure is also applied to the ejector pieces (24).
5. A punch-and-die assembly for cutting out jigsaw puzzles, characterised by upper and lower tools (10,12) with cooperating lands (20) and apertures (22) so arranged, that the lands of each tool are spaced from one another by the apertures (22) located therebetween, the apertures (22) of the upper tool (10) corresponding with the lands (20) of the lower tool (12) and vice versa, so that, when the assembly is in use, adjacent pieces of the jigsaw puzzle are cut out one by a land (20) of the upper tool (10) and a cooperating aperture (22) of the lower tool (12) and the other by a land (20) of the lower tool (12) and a cooperating aperture (22) of the upper tool (10).
6. Assembly according to Claim 5 wherein the apertures (22) of each tool (10,12) each accommodate ejector pieces (24) that are resiliently urged into a condition in which their workpiece-contacting surfaces are flush with those of the adjacent lands (20), and further wherein, as the upper and lower tools (10,12) are urged together in a cutting operation, a counter-pressure is applied to the ejector pieces.
7. A jigsaw puzzle characterised in that the pieces of the puzzle are cut out using a method according to any one of Claims 1 to 4.
8. A jigsaw puzzle according to Claim 7 which is double-sided.

### Patentansprüche

1. Verfahren zur Herstellung von Puzzlen, bei welchem ineinandergreifende Teile aus einer einzigen Materiallage in einem einzigen Stanzhub ausgestanzt werden, gekennzeichnet durch den Einsatz eines Schnittwerkzeugs, welches obere und untere Werkzeuge (10, 12) mit zusammenwirkenden

- Schneidrücken (20) und Öffnungen (22) beinhaltet, wobei von nebeneinanderliegenden Teilen des Puzzles eines durch einen Schneidrücken (20) des oberen Werkzeuges (10) und eine zusammenwirkende Öffnung (22) des unteren Werkzeuges (12), und das andere durch einen Schneidrücken (20) des unteren und eine zusammenwirkende Öffnung (22) des oberen Werkzeuges (10) ausgestanzt wird, und die Öffnungen (22) jedes Werkzeuges durch die Schneidrücken (20) dieses Werkzeuges bestimmt werden.
2. Verfahren gemäß Anspruch 1, bei welchem die Materiallage, aus der die ineinandergreifenden Teile ausgestanzt werden, aus Pappe ist und auf mindestens einer Seite eine Abbildung hat.
3. Verfahren gemäß Anspruch 1, bei welchem die Materiallage, aus der die ineinandergreifenden Teile ausgestanzt werden, aus Sperrholz ist und auf mindestens einer Seite eine Abbildung hat.
4. Verfahren gemäß einem der vorgenannten Ansprüche, bei welchem Auswerferstücke (24) in den Öffnungen (22) jedes Werkzeuges (10, 12) angebracht sind und federnd in einen Zustand gedrückt werden, in welchem ihre am Arbeitsstück anliegenden Oberflächen mit denen der danebenliegenden Schneidrücken (20) bündig sind, und bei welchem weiterhin ein Gegendruck auf die Auswerferstücke (24) ausgeübt wird, wenn die oberen und unteren Werkzeuge (10, 12) bei einem Stanzvorgang gegeneinander gedrückt werden.
5. Ein Schnittwerkzeug zum Ausstanzen von Puzzlen, gekennzeichnet durch obere und untere Werkzeuge (10, 12) mit zusammenwirkenden Schneidrücken (20) und Öffnungen (22), die so angebracht sind, daß die Schneidrücken jedes Werkzeuges durch die zwischen diesen angebrachten Öffnungen (22) voneinander auf Abstand gehalten werden, wobei die Öffnungen (22) des oberen Werkzeuges (10) mit den Schneidrücken (20) des unteren Werkzeuges (12) übereinstimmen und umgekehrt, sodaß beim Einsatz des Werkzeugs von den nebeneinanderliegenden Teilen des Puzzles eines durch einen Schneidrücken (20) des oberen Werkzeuges (10) und eine zusammenwirkende Öffnung (22) des unteren Werkzeuges (12) ausgestanzt wird, und das andere durch einen Schneidrücken (20) des unteren Werkzeuges (12) und eine zusammenwirkende Öffnung (22)

des oberen Werkzeuges.

6. Schnittwerkzeug gemäß Anspruch 5, bei welchem die Öffnungen (22) jedes Werkzeuges (12) Auswerferstücke (24) aufnehmen, die federnd in einen Zustand gedrückt werden, in welchem ihre am Arbeitsstück anliegenden Oberflächen mit denen der danebenliegenden Schneidrücken (20) bündig sind und bei welchem weiterhin ein Gegendruck auf die Auswerferstücke ausgeübt wird, wenn die oberen und unteren Werkzeuge (10, 12) bei einem Stanzvorgang gegeneinander gedrückt werden.
7. Ein Puzzle dadurch gekennzeichnet, daß die Teile des Puzzles mit einem Verfahren gemäß einem der Ansprüche 1 bis 4 ausgestanzt werden.
8. Ein Puzzle gemäß Anspruch 7, welches doppelseitig ist.

#### Revendications

1. Procédé de fabrication de puzzles dans lequel des pièces s'emboîtant de celui-ci sont découpées dans une feuille unique de matériau en une seule opération de découpe, caractérisé par l'utilisation d'un assemblage à poinçon-et-matrice comprenant des outils supérieur et inférieur (10, 12) présentant des crêtes de taillant (20) et des ouvertures (22) coopératrices, dans lequel des pièces de puzzle adjacentes sont découpées l'une par une crête de taillant (20) de l'outil supérieur (10) et une ouverture (22) coopératrice de l'outil inférieur (12) et l'autre par une crête de taillant (20) de l'outil inférieur (10) et une ouverture coopératrice (22) de l'outil supérieur (10), les ouvertures (22) de chaque outil étant définies par les crêtes de taillant (20) de cet outil.
2. Procédé selon la revendication 1, dans lequel la feuille de matériau dans laquelle les pièces s'emboîtant sont découpées est du carton présentant une image sur au moins l'un des côtés.
3. Procédé selon la revendication 1, dans lequel la feuille de matériau dans laquelle les pièces s'emboîtant sont découpées est du contreplaqué présentant une image sur au moins l'un des côtés.
4. Procédé selon l'une quelconque des revendications précédentes, dans lequel les éléments éjecteurs (24) sont logés dans les ouvertures (22) de chaque outil (10, 12) et sont poussés

de manière élastique dans un état dans lequel leurs surfaces de contact avec la pièce à travailler sont alignées avec celles des crêtes de taillant (20) adjacentes,

et en outre dans lequel, lorsque les outils supérieur et inférieur (10, 12) sont poussés l'un vers l'autre dans une opération de coupe, une contre-pression est également appliquée aux éléments éjecteurs (24).

5

10

5. Assemblage à poinçon-et-matrice pour découper des puzzles, caractérisé par des outils supérieur et inférieur (10, 12) ayant des crêtes de taillant (20) et des ouvertures (22) en coopération disposées de telle sorte que les crêtes de taillant de chaque outil sont espacées les unes des autres par les ouvertures (22) situées entre celles-ci, les ouvertures (22) de l'outil supérieur (10) correspondant aux crêtes de taillant (20) de l'outil inférieur (12) et vice versa, de sorte que, lorsque l'assemblage est en cours d'utilisation, des pièces adjacentes du puzzle sont découpées l'une par une crête de taillant (20) de l'outil supérieur (10) et une ouverture coopératrice (22) de l'outil inférieur (12) et l'autre par une crête de taillant (20) de l'outil inférieur (12) et une ouverture coopératrice (22) de l'outil supérieur (10).

15

20

25

6. Assemblage selon la revendication 5, dans lequel les ouvertures (22) de chaque outil (10, 12) loge chacune des éléments éjecteurs (24) qui sont poussés de manière élastique dans un état dans lequel leurs surfaces de contact avec la pièce à travailler sont alignées avec celles des crêtes de taillant (20) adjacentes, et en outre dans lequel, lorsque les outils supérieur et inférieur (10, 12) sont poussés l'un vers l'autre dans une opération de coupe, une contre-pression est appliquée aux éléments éjecteurs.

30

35

40

7. Puzzle, caractérisé en ce que les pièces du puzzle sont découpées en employant un procédé selon l'une quelconque des revendications 1 à 4.

45

8. Puzzle selon la revendication 7, qui est à double face.

50

55

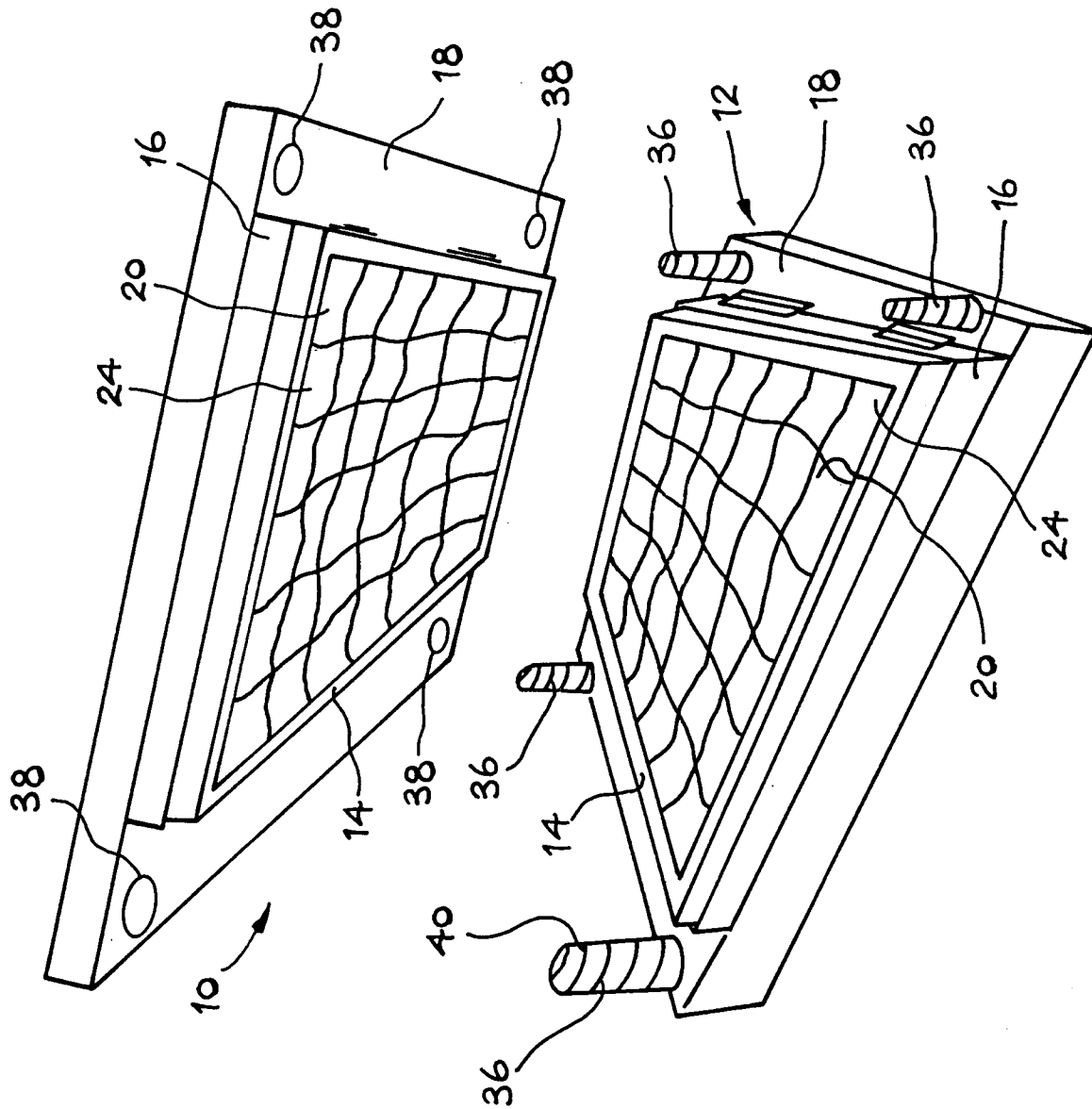

FIG-1

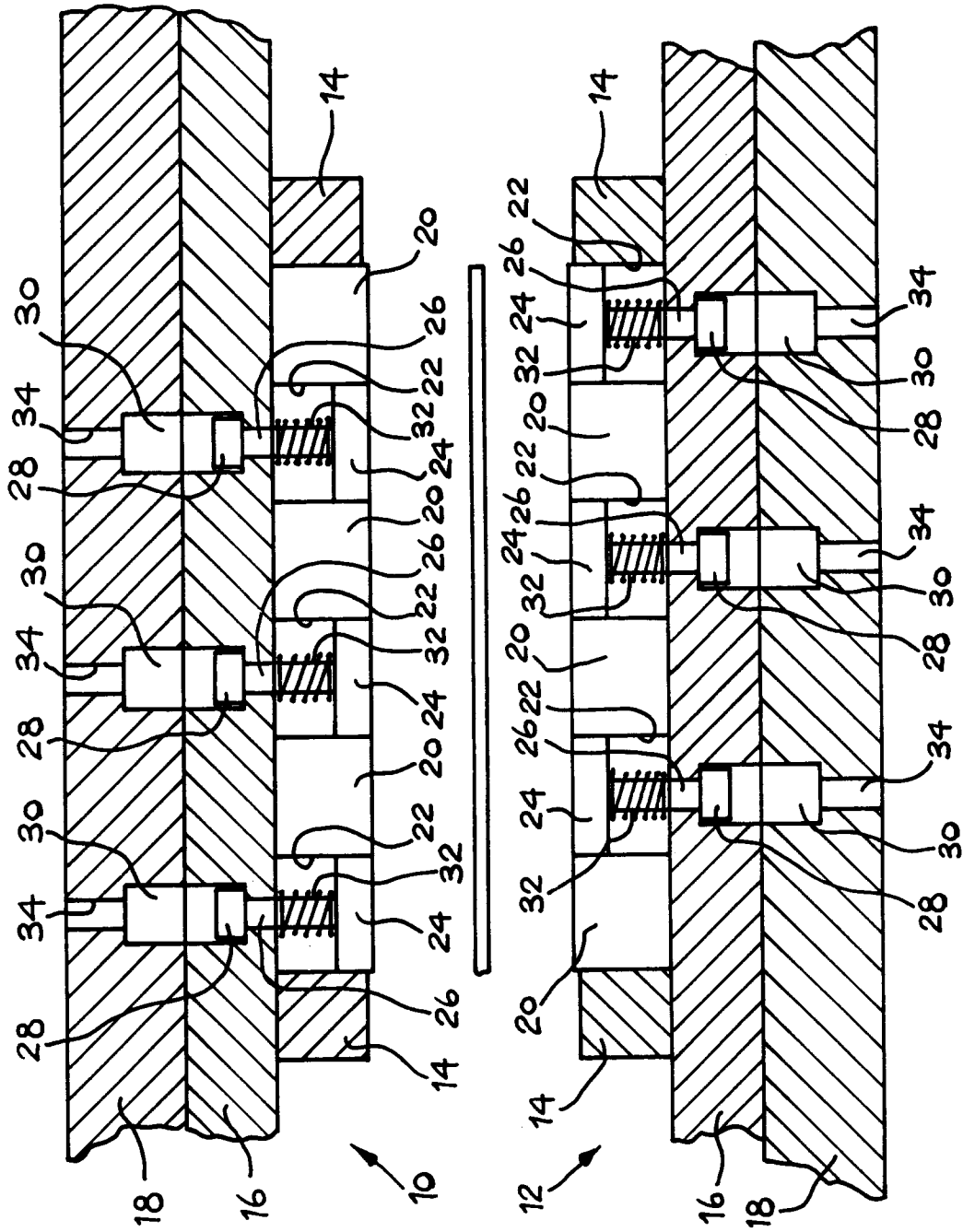

FIG-2



Fig-3