

April 5, 1949.

C. W. BERTHIEZ

2,466,199

TURRET HEAD

Filed May 4, 1945

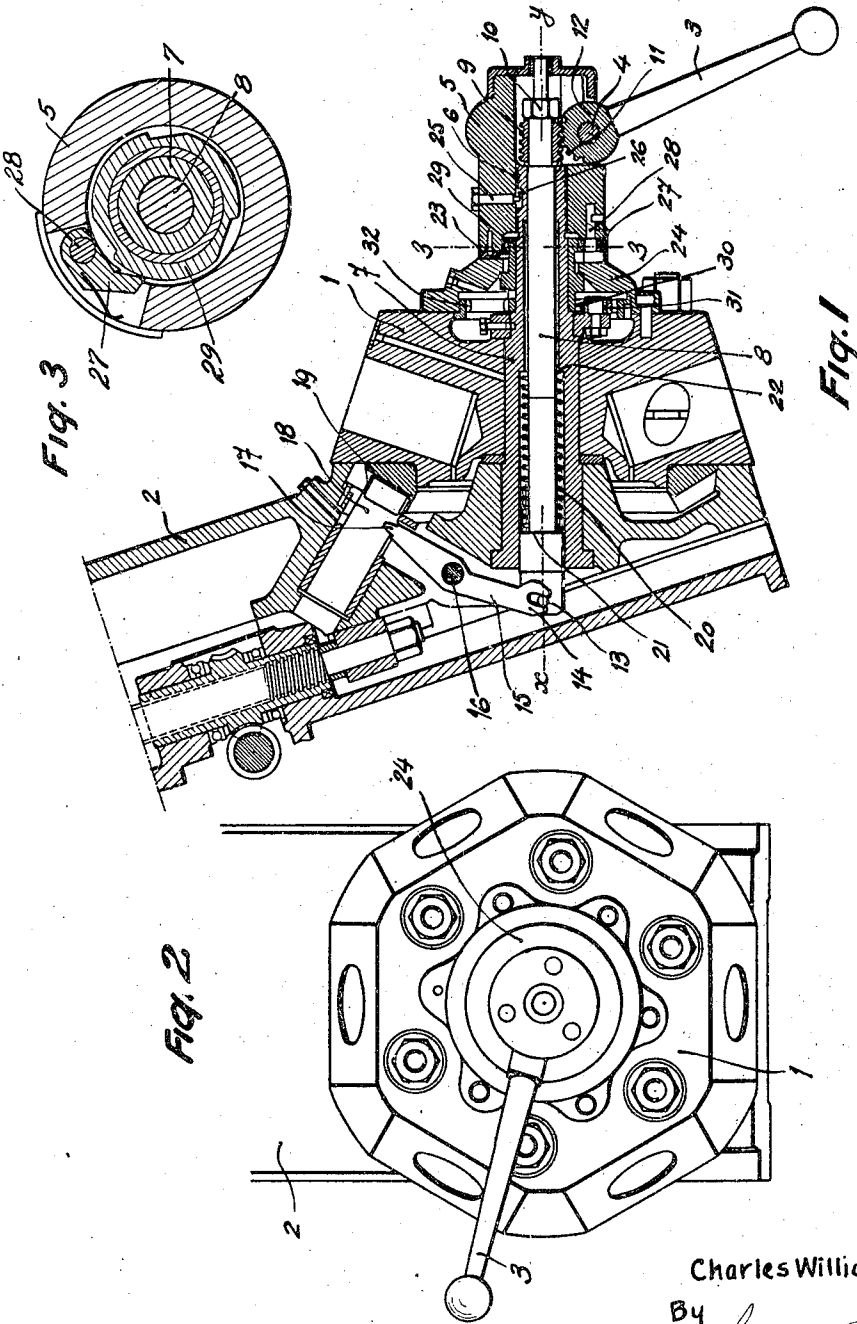

Fig. 3

Fig. 1

Fig. 2

Charles William Berthiez
INVENTOR
By *George Moorey*
His Attorney

UNITED STATES PATENT OFFICE

2,466,199

TURRET HEAD

Charles William Berthiez, Paris, France

Application May 4, 1945, Serial No. 592,013
in France December 1, 1941

Section 1, Public Law 690, August 8, 1946
Patent expires December 1, 1961

4 Claims. (Cl. 29—49)

1

The present invention relates to turret-heads for machine tools and the like, and more particularly to means for indexing and clamping the turret-head selectively in a plurality of positions for holding the tools in relation to the work piece.

There exist control devices for turret-heads in which the operation is controlled by means of a single lever which successively ensures the following operations: unclamping, unlocking, rotary displacement and locking of the turret-head. In such devices, the movements required of the man who operates the machine are not always rational and furthermore, the mechanism is greatly complicated and is defective from the point of view of efficiency and quickness of operation.

An object of the present invention is to provide a device of the type above mentioned, which is simple, efficient and reliable and which can be operated smoothly and quickly, involving only natural movements for the man who controls the machine.

Another object of the present invention is to provide a mechanism which, in view of its great simplicity, is not very costly to manufacture and eliminates any risk of breakdown.

A characteristic of the present invention lies in the utilization of kinematic devices which provide for speed reduction, which permit operating the machine smoothly and without having to apply great effort, and the operation of which is effected in four steps by means of a single lever and in the following manner:

1st step: rotation of the lever in one direction about the axis of the turret-head so as to ensure the unclamping thereof;

2nd step: movement of the lever preferably toward the turret-head, in the direction parallel to the axis of the turret-head so as to ensure the unlocking thereof;

3rd step: rotation of the lever about the axis of the turret-head in the same direction as above which secures unclamping of the turret-head, while the lever is kept for a short time in the position to which it was moved in the second step in order to move the turret-head from one locking position to another to bring a new tool into operative position so as to produce the displacement of the turret-head.

4th step: rotation of the lever about the axis of the turret-head, but in the opposite direction to the rotation of the first step and until further movement becomes impossible by virtue of the clamping of the turret in position.

2

Other features of the present invention will appear from the following detailed description of a specific embodiment thereof.

A preferred embodiment of the present invention will be hereinafter described with reference to the accompanying drawings given merely by way of example and in which:

Figure 1 is a transverse section of the turret-head control device constituted according to one embodiment of the invention;

Figure 2 is an elevation taken from the right in Figure 1; and

Figure 3 is a sectional view on the line IV—IV of Figure 1.

As shown in Figs. 1 and 2 of the drawing, the control device for turret-head 1 mounted on arm 2 of the machine-tool (vertical lathe with a single upright in the example shown) includes a single lever 3 which permits of ensuring, under conditions which will be hereinafter set forth, the unclamping, the unlocking, a displacement of the turret-head corresponding to one or several sections and indexing this turret-head in the new position, and the reclamping of said turret-head in the new position.

This lever 3 is mounted on a pivot pin 4, itself carried by a rotatable piece 5 which is capable of turning about the axis $x-y$ of the turret-head which is at a right angle to the axis of the lever 3 and to the plane of rotation of turret-head 1. Piece 5 is threaded at 6 on the hollow shaft 7.

Inside this shaft 7 the control rod 8 is slidably supported and is provided at one of its ends with a sleeve 9 provided with circular rack teeth and kept in position by means of a nut 10. This sleeve 9 meshes with the teeth 11 carried by a hub 12 rigid with lever 3. At the other end, rod 8 carries a pin 13 engaged in a fork 14 provided at the end of a lever 15 adapted to pivot upon a stud 16. The other end of lever 15 carries a finger 17 which engages in a slot of a locking piece 18 which, in the position shown in Figure 1, serves to lock turret-head 1 in position owing to the fact that said piece 18 engages in one of the notches 19 provided in the turret-head.

The turret-head at its left hand face is provided with as many notches 19 as there are different positions to be occupied by said turret-head by rotation thereof on the shaft 7. A spring 20 bearing against a shoulder portion 21 of rod 8 and against shoulder 22 of hollow shaft 7, constantly urges rod 8 toward the left, Fig. 1, and therefore tends to keep locking piece 18 engaged in the notch 19.

Rotary piece 5 carries, at its inner end, shoes

3

4

23 which come, when the turret-head is clamped, to bear strongly against the front surface of a flanged piece 24 fastened to turret-head 1. A screw 25, the end of the stem of which engages in a circular groove 26 of fixed hollow shaft 7, serves to limit, in the direction of axis $x-y$, the displacement of piece 5.

In order to permit of rotating turret-head 1, I make use of a pawl 27, Figs. 1 and 3, which is mounted on pin 28 fastened in rotary piece 5. This pawl can come into mesh with a ratchet wheel 29 fixed on a toothed wheel 30. Toothed wheel 30 meshes with a pinion 31 which is free to rotate about its axis and, in turn, meshes with ring gear 32 provided with internal teeth and which is rigid with the turret-head.

The operation of the device according to the invention will be further understood from the following description of the various operations which are effected by moving the single control lever 3, which has a combined double movement, as above explained.

1. Unclamping

When lever 3 is turned through a certain angle, for example, in a counterclockwise direction, Fig. 2, it rotates piece 5 which is screwed at 6 on fixed shaft 7. This effects unscrewing movement and serves to bring bearing shoes 23 away from turret-head 1 and therefore produces the unclamping thereof.

2. Unlocking

From this time on, in order to unlock the turret-head, it is necessary to push and hold lever 3 toward the left, Fig. 1. This lever, in the course of its pivoting movement about its pin 4 toward the turret-head, displaces locking piece 18, through rod 8 and lever 15, bringing said piece 18 out from one of the notches 19 which serve to position the turret-head.

3. Rotation of the turret-head

In order to displace the turret-head through an angular space corresponding to one section, it is necessary further to rotate lever 3 through the proper angle in the same direction as for the unclamping operation, that is, counterclockwise in Fig. 2, until locking piece 18 drops, under the thrust of spring 29, into the next or any desired positioning or indexing notch 19. In the course of this movement, lever 3 rotates on axis $x-y$ both rotary piece 5 and pawl 27 carried thereby. The pawl 27, in turn, drives ratchet wheel 29. The toothed wheel 30 which is fixed to this ratchet wheel is thus caused to rotate and consequently drives pinion 31, whereby toothed ring 32 which is rigid with the turret-head is caused to rotate. The turret head is thus driven in the particular embodiment being described in a direction opposed to that of lever 3 because of the intervention of the internal gear train 30, 31, 32.

If it is desired to rotate the turret-head 1 through an angle corresponding to several sections, it is merely necessary to keep lever 3 depressed toward the turret-head, so as to prevent locking piece 8 from dropping into locking notches 19 corresponding to any intermediate position until the desired position is reached.

4. Clamping

In order to effect the clamping of the turret-head, it suffices to bring back lever 3 into its clamping position, that is to say to turn it in the clockwise direction, Fig. 2, until it can no longer turn, which has for its effect to move piece 5 to-

ward the turret-head by virtue of its screw thread engagement with hollow shaft 7, and to apply bearing shoes 23 against flanged piece 24 carried thereby.

It results from the preceding description that the above set forth operations are effected in a manner which is both simple and safe, by means of the single lever 3 which can be given a combined double movement, to wit: a pivotal movement toward the turret-head and a movement of rotation on the axis of the turret-head. This permits in particular to keep the turret-head unlocked during the rotation thereof through any angle corresponding to one or several sections. Under these conditions, it is possible, without any supplementary operation producing a loss of time, to rotate said turret-head to any desired section or tool position.

Of course, the device according to the invention which has been shown in the drawing, by way of example, as applied to a machine tool, such as a vertical lathe having a single upright, may be applied to any other kind of machine-tools and to any machines or apparatus where a turret-head is utilized.

In a general manner, while I have in the above description disclosed what I deem to be a practical and efficient embodiment of the present invention, it should be well understood that I do not wish to be limited thereto as changes may be made in the arrangement, disposition and form of the parts without departing from the principle of the present invention as comprehended within the scope of the appended claims.

What I claim is:

1. A device which comprises, in combination, a frame, a fixed shaft carried by said frame, a structure rotatable upon the axis of said shaft and provided with a plurality of notches disposed about the axis of said structure, a rod slidable axially relative to said shaft, a bolt slidable in said frame adapted to engage in any of said notches when rotated into register therewith for locking said structure with respect to said frame, a lever pivoted to said frame and interposed between and operatively connected to said rod and said bolt for effecting sliding movement of said bolt into and out of locking engagement by sliding displacement of said rod relative to said shaft respectively in one direction and the other, a piece coaxially supported by said shaft in screwing engagement thereon, said piece being adapted to screw into and out of clamping engagement with said rotatable structure, unidirectional mechanical transmission means between said piece and said structure, whereby said structure is caused to rotate about said shaft by said piece rotating in the direction which moves it axially away from said structure, a control lever pivoted to said piece about an axis at right angles to the axis of said shaft and adapted by rotation of said lever about said shaft axis to drive said piece in rotation about said shaft to effect clamping and unclamping action thereof, and a continuous connection between said control lever and said rod for moving said rod axially relative to said shaft in all positions of said lever about said shaft upon pivotal movement of said lever.

2. A device which comprises, in combination, a frame, a fixed shaft carried by said frame, a structure rotatable upon the axis of said shaft, a rod slidable axially relative to said shaft, means for locking said rotatable structure with respect to said frame and operatively connected to said rod so as to be brought into and out of locking engage-

5

ment with said rotatable structure upon sliding displacement of said rod relative to said shaft respectively in one direction and the other, a piece coaxially supported on said shaft in screwing engagement thereon, said piece being adapted to screw into and out of clamping engagement with said rotatable structure, unidirectional mechanical transmission means between said piece and said structure, whereby said structure is caused to rotate about said shaft by said piece rotating in the direction which moves it axially away from said structure, a control lever pivoted to said piece about an axis at right angles to the axis of said shaft and adapted by rotation of said lever about said shaft axis to drive said piece in rotation about said shaft to effect clamping and unclamping action thereof, and a continuous connection between said control lever and said rod for moving said rod axially relative to said shaft in all positions of said lever about said shaft upon pivotal movement of said lever.

3. A device which comprises, in combination, a frame, a fixed shaft carried by said frame, a structure rotatable upon the axis of said shaft, a rod slidable axially relative to said shaft, means for locking said rotatable structure with respect to said frame and operatively connected to said rod so as to be brought into and out of locking engagement with said rotatable structure upon sliding displacement of said rod relative to said shaft respectively in one direction and the other, a piece coaxially surrounding said shaft and in screwing engagement thereon, said piece being adapted to screw into and out of clamping engagement with said rotatable structure, unidirectional mechanical transmission means between said piece and said structure, whereby said structure is caused to rotate about said shaft by said piece rotating in the direction which moves it axially away from said structure, a control lever pivoted to said piece about an axis at right angles to the axis of said shaft, a toothed sector carried by said lever, and circular rack teeth carried by the end of said rod in mesh with said sector, whereby rotation of said lever about its pivotal axis displaces said rod axially relative to said shaft, said control lever being adapted by rotation about the shaft axis to drive said piece in rotation about said shaft.

6

4. A device which comprises, in combination, a frame, a fixed shaft carried by said frame, a structure rotatable upon the axis of said shaft, a rod slidable axially relative to said shaft, means for locking said rotatable structure with respect to said frame and operatively connected to said rod so as to be brought into and out of locking engagement with said rotatable structure upon sliding displacement of said rod relative to said shaft respectively in one direction and the other, a piece coaxially surrounding said shaft and in screwing engagement thereon, said piece being adapted to screw into and out of clamping engagement with said rotatable structure, a driven gear carried by said rotatable structure coaxially therewith, a ratchet wheel coaxial with said shaft axis, a gear transmission between said ratchet wheel and said driven gear for driving said driven gear to rotate said structure upon rotation of said ratchet wheel, a pawl carried by said piece and adapted to engage said ratchet wheel to rotate said ratchet wheel when said piece is rotating in the direction which moves it axially away from said structure, a control lever pivoted to said piece about an axis at right angles to the axis of said shaft and adapted by rotation of said lever about said shaft axis to drive said piece in rotation about said shaft to effect clamping and unclamping action thereof, and a continuous connection between said control lever and said rod for moving said rod axially relative to said shaft in all positions of said lever about said shaft upon pivotal movement of said lever.

CHARLES WILLIAM BERTHIEZ.

REFERENCES CITED

The following references are of record in the file of this patent:

UNITED STATES PATENTS

Number	Name	Date
1,098,688	Schellenbach et al.	June 2, 1914
1,140,733	Burrell	May 25, 1915
1,664,351	Class	Apr. 3, 1928
1,748,348	Hyatt	Feb. 25, 1930

FOREIGN PATENTS

Number	Country	Date
114,954	Germany	Dec. 15, 1900
361,912	Germany	Oct. 20, 1920