



Europäisches Patentamt  
European Patent Office  
Office européen des brevets



(11) **EP 0 907 159 B1**

(12) **EUROPEAN PATENT SPECIFICATION**

(45) Date of publication and mention  
of the grant of the patent:  
**12.09.2001 Bulletin 2001/37**

(51) Int Cl.7: **G09G 3/36, G02F 1/136**

(21) Application number: **98110819.4**

(22) Date of filing: **12.06.1998**

(54) **Active matrix liquid crystal display panel and method of driving the same**

Flüssigkristallanzeigegerät mit aktiver Matrix und Steuerungsverfahren dafür

Panneau d'affichage à cristaux liquides à matrice active et sa méthode de commande

(84) Designated Contracting States:  
**DE FR GB**

(30) Priority: **13.06.1997 JP 15690097**

(43) Date of publication of application:  
**07.04.1999 Bulletin 1999/14**

(73) Proprietor: **MATSUSHITA ELECTRIC INDUSTRIAL  
CO., LTD.  
Kadoma-shi, Osaka (JP)**

(72) Inventor: **Otani, Teruya  
Kanazawa-shi, Ishikawa 921-8034 (JP)**

(74) Representative:  
**Pellmann, Hans-Bernd, Dipl.-Ing. et al  
Patentanwaltsbüro  
Tiedtke-Bühling-Kinne & Partner  
Bavariaring 4-6  
80336 München (DE)**

(56) References cited:  
**EP-A- 0 373 565 EP-A- 0 535 954  
EP-A- 0 622 655 EP-A- 0 691 565  
US-A- 5 517 342**

- **PATENT ABSTRACTS OF JAPAN vol. 98, no. 10,  
31 August 1998 & JP 10 123482 A (MATSUSHITA  
ELECTRIC IND. CO. LTD.), 15 May 1998**

**EP 0 907 159 B1**

Note: Within nine months from the publication of the mention of the grant of the European patent, any person may give notice to the European Patent Office of opposition to the European patent granted. Notice of opposition shall be filed in a written reasoned statement. It shall not be deemed to have been filed until the opposition fee has been paid. (Art. 99(1) European Patent Convention).

## Description

### BACKGROUND OF THE INVENTION

#### Field of the Invention

**[0001]** The present invention relates to a liquid crystal display panel in which a TFT (thin film transistor) array is driven to display OA images and video images, and a method of driving the same.

#### Description of the Prior Art

**[0002]** Examples of conventional liquid crystal display panels include one disclosed in Japanese Laid-open Patent Application No. H2-913. FIG. 8 is a circuit diagram showing the structure of the conventional liquid crystal display panel. In FIG. 8, reference numeral 1 represents a pixel, reference numeral 2 represents a TFT, reference numeral 3 represents a pixel electrode connected to the drain electrode of the TFT 2, reference numeral 4 represents a liquid crystal capacitance formed between a counter electrode 6 and the pixel electrode 3, reference numeral 5 represents an auxiliary capacitance for supplementing the storing property of the liquid crystal capacitance 4, reference numeral 7 represents a scanning electrode connected to the gate electrode of the TFT 2 for supplying a scanning signal to control on and off of the TFT 2, and reference numeral 9 represents a signal electrode connected to the source electrode of the TFT 2 for supplying an image signal to the pixel electrode 3 through the TFT 2.

**[0003]** FIG. 9 is an equivalent circuit diagram of a pixel (i, j) of the conventional liquid crystal display panel when the TFT 2 is off. In FIG. 9, Cgd represents a gate-drain capacitance between the gate electrode and the drain electrode of the TFT 2, and Csd<sub>1</sub> and Csd<sub>2</sub> represent signal electrode-pixel electrode capacitances between the signal electrode 9 and the pixel electrode 3.

**[0004]** FIGs. 10(a) to 10(b) are signal waveform charts of the conventional liquid crystal display panel. FIG. 10(a) is a signal waveform chart at the pixel (i, j). FIG. 10(b) is a signal waveform chart at a pixel (i+1, j). FIG. 10(c) is a signal waveform chart at a pixel (i+2, j). In these figures, 1H represents a horizontal scanning period, 1V represents a vertical scanning period, Vc represents a counter signal applied to the counter electrode 6, Vg represents a scanning signal applied to the scanning electrode 7 and supplied to the gate electrode of the TFT 2, Vs represents an image signal applied to the signal electrode 9 and supplied to the source electrode of the TFT 2, Vd represents the potential of the pixel electrode 3 connected to the drain electrode of the TFT 2, Vge+ represents a positive modulating voltage, and Vge- represents a negative modulating voltage. In this conventional display panel, the magnitude of the positive modulating voltage Vge+ is 3 V (=19 V - 16 V), and the magnitude of the negative modulating voltage Vge-

is 11 V (=16 V - 5 V).

**[0005]** With respect to the conventional liquid crystal display panel thus structured, an operation thereof will be described.

5 **[0006]** At the pixel (i, j), when the scanning signal Vg(i+1) is on for the 1H period, the image signal Vs(j) is supplied to the pixel electrode 3 serving as one of the electrodes of the liquid crystal capacitance 4 and the auxiliary capacitance 5, so that a predetermined voltage is reached. When the scanning signal Vg(i+1) becomes off, it is attempted to maintain the voltage for the 1V period; however, since the auxiliary capacitance 5 is connected to the preceding scanning electrode 7, when the scanning signal Vg(i) changes to the positive modulating voltage Vge+ or to the negative modulating voltage Vge-, the potential Vd(i, j) of the pixel electrode 3 changes accordingly. Thus, an effective voltage as well as the image signal Vs(j) is applied to the liquid crystal capacitance 4. The same is performed at the pixel (i+1, j) and at the pixel (i+2, j), etc., so that an image is displayed on the entire screen.

10 **[0007]** However, in the conventional structure, as shown in FIGs. 10(a) to 10(c), the positive modulating voltage Vge+ and the negative modulating voltage Vge- must be superimposed on the scanning signal Vg, and the modulating voltages necessarily have an amplitude of several tens of volts. Consequently, the output IC for outputting the scanning signal Vg of up to approximately 38 V to the scanning electrode 7 is a process which withstands a very high voltage, and requires a four-value level output, so that the chip area increases. As a result, the cost of the IC significantly increases.

15 **[0008]** Moreover, as shown in FIG. 11, since the auxiliary capacitance 5 is formed between the pixel electrode 3 and the scanning electrode 7, the load capacitance of the scanning electrode 7 increases. Further, since the width of the scanning electrode 7 cannot be reduced so much in forming the auxiliary capacitance 5, the numerical aperture is sacrificed. Moreover, the load on the output IC increases as the screen size and the density of the liquid crystal display panel increase, so that the difference in load capacitance between the left and right sides of the screen degrades the display quality.

20 **[0009]** Moreover, since pixels in the same row are supplied with the image signal Vs of the same polarity and supplied with the image signal Vs of a different polarity every 1H period, the potential Vd of the pixel electrode 3 is swung through the signal electrode-pixel electrode capacitances Csd<sub>1</sub> and Csd<sub>2</sub> every time the polarity of the image signal Vs changes, so that crosstalk is caused. As a result, the display quality is significantly degraded.

25 **[0010]** Documents EP 0 535 954 A, US 5 517 342 A and EP 0 373 565 A describe active matrix liquid crystal displays with auxiliary capacitors and modulating electrodes connected to the same, having a modulating electrode simply arranged in each row and connected

to one end of the auxiliary capacitors corresponding to pixels in that row.

#### SUMMARY OF THE INVENTION

**[0011]** An object of the present invention is to provide a liquid crystal display panel and a method of driving the same in which the output amplitude of the output IC for outputting the scanning signal is restrained, the cost of the IC is greatly reduced by using a low-voltage process, the load capacitance of the scanning electrode is reduced and the numerical aperture is improved.

**[0012]** Another object of the present invention is to provide a liquid crystal display panel and a method of driving the same in which, in addition to the above-mentioned object, high-quality image display without any crosstalk is realized.

**[0013]** A liquid crystal display panel of the present invention is a liquid crystal display panel in which a plurality of pixel electrodes are arranged in  $m$  rows and in  $n$  columns on a light transmitting substrate,  $m$  rows of scanning electrodes and  $n$  columns of signal electrodes are perpendicularly arranged between the plurality of pixel electrodes, a thin film transistor in which a gate electrode is connected to a scanning electrode in an  $i$ -th row ( $i$  is an integer among 1 to  $m$ ), a source electrode is connected to a signal electrode in a  $j$ -th column ( $j$  is an integer among 1 to  $n$ ) and a drain electrode is connected to a pixel electrode in the  $i$ -th row in the  $j$ -th column is disposed at each intersection of the scanning electrode and the signal electrode, and a counter electrode which is opposed to the pixel electrode with liquid crystal between is disposed. The liquid crystal display panel is characterized in that the following modulating electrodes are provided: a modulating electrode in a first row between which and the pixel electrode in the first row in a  $p$ -th column ( $p$  is an odd number or an even number among 1 to  $n$ ), an auxiliary capacitance is formed; a modulating electrode in a  $k$ -th row between which and the pixel electrode in a  $k$ -th row in the  $p$ -th column ( $k$  is an integer among 2 to  $m$ ) and in the  $(k-1)$ -th row in a  $q$ -th column ( $q$  is an integer other than  $p$  among 1 to  $n$ ), the auxiliary capacitance is formed; and a modulating electrode in an  $(m+1)$ -th row between which and the pixel electrode in the  $m$ -th row in the  $q$ -th column, the auxiliary capacitance is formed.

**[0014]** According to this structure, since the modulating electrode between which and each of the pixel electrodes, the auxiliary capacitance is formed is provided separately from the scanning electrode, the amplitude of the scanning signal output from the output IC so as to be applied to the scanning electrode is greatly reduced and the level output is binary, so that the area of the IC chip is greatly reduced. As a result, the cost of the IC is greatly reduced. Moreover, since the auxiliary capacitance is formed not between the pixel electrode and the scanning electrode like in the conventional structure, the load capacitance of the scanning elec-

trode is reduced. Further, since the auxiliary capacitance is formed between the pixel electrode and a different modulating electrode for each column and an image signal whose polarity is reversed for each column of the signal electrode is supplied, the potentials of the pixel electrodes are swung from the signal electrodes on both sides so as to cancel each other through the capacitance between the signal electrodes, so that the potentials of the pixel electrodes are not swung but become stable. As a result, crosstalk disappears and the display quality is significantly improved.

**[0015]** Further, the liquid crystal display panel is characterized in that the modulating electrodes in the first to the  $(m+1)$ -th rows are formed by use of a light transmitting conductive material, the modulating electrode in the first row is provided between the pixel electrode in the first row in the  $p$ -th column and the light transmitting substrate with a light transmitting insulating film between the pixel electrode in the first row in the  $p$ -th column and the modulating electrode in the first row, the modulating electrode in the  $k$ -th row is provided between the pixel electrodes in the  $k$ -th row in the  $p$ -th column and in the  $(k-1)$ -th row in the  $q$ -th column and the light transmitting substrate with the light transmitting insulating film between the pixel electrodes in the  $k$ -th row in the  $p$ -th column and in the  $(k-1)$ -th row in the  $q$ -th column and the modulating electrode in the  $k$ -th row, and the modulating electrode in the  $(m+1)$ -th row is provided between the pixel electrode in the  $m$ -th row in the  $q$ -th column and the light transmitting substrate with the light transmitting insulating film between the pixel electrode in the  $m$ -th row in the  $q$ -th column and the modulating electrode in the  $(m+1)$ -th row.

**[0016]** Thus, since the modulating electrode using the light transmitting conductive material is provided below the pixel electrode and the load capacitance of the scanning electrode is reduced, the width of the scanning electrode can be reduced to significantly improve the numerical aperture.

**[0017]** Moreover, a method of driving a liquid crystal display panel of the present invention is a method of driving the above-described liquid crystal display panel of the present invention, and is characterized in that a potential of the pixel electrode is controlled through the auxiliary capacitance by supplying to the signal electrodes image signals whose polarity is reversed at every column of the  $n$  columns of the signal electrodes, the polarity of the image signal applied to each signal electrode being reversed every horizontal scanning period, and applying a positive modulating voltage and a negative modulating voltage to each modulating electrode.

**[0018]** According to the driving method, since the potential of the pixel electrode is controlled through the auxiliary capacitance by applying a positive modulating voltage and a negative modulating voltage to the modulating electrode, the load capacitance of the scanning electrode is reduced, so that the width of the scanning electrode can be reduced to significantly improve the

numerical aperture. Further, since the image signal whose polarity is reversed every column of the signal electrode is supplied, the potentials of the image electrodes are swung from the signal electrodes on both sides so as to cancel each other through the capacitance between the signal electrodes, so that the potentials of the pixel electrodes are not swung but become stable. As a result, crosstalk disappears and the display quality is significantly improved.

#### BRIEF DESCRIPTION OF THE DRAWINGS

##### [0019]

FIG. 1 is a circuit diagram showing the structure of an improved liquid crystal display panel;

FIGs. 2 (a) and 2 (b) are a plan view and a cross-sectional view, respectively, showing the structure of an auxiliary capacitance of such improved liquid crystal display panel;

FIGs. 3(a) to 3(c) are signal waveform charts of the improved liquid crystal display panel;

FIG. 4 is a circuit diagram showing the structure of a liquid crystal display panel according to an embodiment of the present invention;

FIGs. 5 (a) and 5(b) are a plan view and a cross-sectional view, respectively, showing the structure of the auxiliary capacitance of the liquid crystal display panel according to the embodiment of the present invention;

FIG. 6 is an equivalent circuit diagram of the pixel (i, j) of the liquid crystal display panel according to the embodiment of the present invention when a TFT is off;

FIGs. 7(a) to (f) are signal waveform charts of the liquid crystal display panel according to the embodiment of the present invention;

FIG. 8 is a circuit diagram showing the structure of the conventional liquid crystal display panel;

FIG. 9 is an equivalent circuit diagram of the pixel (i, j) of the conventional liquid crystal display panel when the TFT is off;

FIGs. 10(a) to 10(c) are signal waveform charts of the conventional liquid crystal display panel; and

FIG. 11 is a plan view showing the structure of the auxiliary capacitance of the conventional liquid crystal display panel.

#### DETAILED DESCRIPTION OF THE PREFERRED EMBODIMENTS

[0020] The present invention will be described with reference to the drawings.

[0021] FIG. 1 is a circuit diagram showing the structure of an improved liquid crystal display panel. In FIG. 1, reference numeral 1 represents a pixel, reference numeral 2 represents a TFT, reference numeral 3 represents a pixel electrode connected to the drain electrode

of the TFT 2, reference numeral 4 represents a liquid crystal capacitance formed between a counter electrode 6 and the pixel electrode 3, reference numeral 5 represents an auxiliary capacitance for supplementing the storing property of the liquid crystal capacitance 4, reference numeral 7 represents a scanning electrode connected to the gate electrode of the TFT 2 for supplying a scanning signal to control on and off of the TFT 2, and reference numeral 9 represents a signal electrode connected to the source electrode of the TFT 2 for supplying an image signal to the pixel electrode 3 through the TFT 2. These elements are similar to those of the conventional liquid crystal display panel and denoted by the same reference numerals as those of FIG. 8. Reference numeral 8 represents a modulating electrode for modulating the potential of the pixel electrode 3.

[0022] Such liquid crystal panel is different from the conventional structure in that the modulating electrode 8 for applying a modulating signal  $V_f$  to modulate the potential  $V_d$  of the pixel electrode 3 through the auxiliary capacitance 5 is provided separately from the scanning electrode 7. That is, the auxiliary capacitance 5 is provided not between the pixel electrode 3 and the scanning electrode 7 like in the conventional structure but between the pixel electrode 3 and the modulating electrode 8.

[0023] The structure of the auxiliary capacitance 5 is shown in FIGs. 2(a) and 2(b). FIG. 2(a) is a plan view showing the structure of the auxiliary capacitance 5. FIG. 2(b) is a cross-sectional view taken on the line A-A of FIG. 2 (a). In these figures, the TFT 2 is not illustrated but shown being simplified. As shown in the figures, the auxiliary capacitance 5 is formed by providing the modulating electrode 8, with a light transmitting insulating film 12 between, below the pixel electrode 3 disposed on a light transmitting substrate 11. Therefore, after the modulating electrode 8 is formed on the light transmitting substrate 11, the light transmitting insulating film 12 is formed on the entire surface, and the pixel electrode 3, the scanning electrode 7 and the signal electrode 9, etc. are formed on the light transmitting insulating film 12. The pixel electrode 3 and the modulating electrode 8 are made of a light transmitting conductive material such as ITO (indium-tin oxide) which a transparent electrode can be formed of. The light transmitting substrate 11 comprises a substrate having light transmitting capability such as glass. The light transmitting insulating film 12 comprises a silicon oxide film ( $\text{SiO}_2$ ), a tantalum oxide film ( $\text{Ta}_2\text{O}_3$ ) or a silicon nitride film ( $\text{SiN}_x$ ).

[0024] FIGs. 3(a) to 3(c) are signal waveform charts of the above described liquid crystal display panel. FIG. 3(a) is a signal waveform chart at the pixel (i, j). FIG. 3 (b) is a signal waveform chart at a pixel (i+1, j). FIG. 3 (c) is a signal waveform chart at a pixel (i+2, j). In these figures, 1H represents a horizontal scanning period, 1V represents a vertical scanning period,  $V_c$  represents a counter signal applied to the counter electrode 6,  $V_g$

represents a scanning signal applied to the scanning electrode 7 and supplied to the gate electrode of the TFT 2,  $V_s$  represents an image signal applied to the signal electrode 9 and supplied to the source electrode of the TFT 2,  $V_d$  represents the potential of the pixel electrode 3 connected to the drain electrode of the TFT 2,  $V_f$  represents a modulating signal applied to the modulating electrode 8 and having a positive modulating voltage  $V_{ge+}$  and a negative modulating voltage  $V_{ge-}$ . The magnitude of the modulating voltage  $V_{ge+}$  is 3 V, and the magnitude of the modulating voltage  $V_{ge-}$  is 11 V ( $=14\text{ V} - 3\text{ V}$ ). These magnitudes are the same as those of the conventional display panel. During a period of 1V, the modulating signal  $V_f$  changes by the magnitude of the voltage  $V_{ge-}$  in the 1H period immediately after the scanning signal  $V_g$  becomes on, is constant until the next 1H period immediately before the scanning signal  $V_g$  becomes on the next time, and then, changes by the magnitude of  $(V_{ge-})-(V_{ge+})$ . During the next 1V period, the modulating signal  $V_f$  changes by the magnitude of  $V_{ge+}$  in the 1H period immediately after the scanning signal becomes on.

**[0025]** With respect to the improved liquid crystal display panel thus structured, an operation thereof will be described.

**[0026]** At the pixel (i, j), when the scanning signal  $V_g$  (i) is on for the 1H period, the image signal  $V_s(j)$  is supplied to the pixel electrode 3 serving as one of the electrodes of the liquid crystal capacitance 4 and the auxiliary capacitance 5, so that a predetermined voltage is reached. When the scanning signal  $V_g(i)$  becomes off, it is attempted to maintain the voltage for the 1V period; however, since the auxiliary capacitance 5 is connected to the modulating electrode 8, when the modulating signal  $V_f(i)$  changes to the positive modulating voltage  $V_{ge+}$  or to the negative modulating voltage  $V_{ge-}$ , the potential  $V_d(i, j)$  of the pixel electrode 3 changes accordingly. Thus, an effective voltage as well as the image signal  $V_s(j)$  is applied to the liquid crystal capacitance 4. The same is performed at the pixel (i+1, j) and at the pixel (i+2, j), etc., so that an image is displayed on the entire screen.

**[0027]** In the conventional display panel, the output IC for outputting the scanning signal  $V_g$  to the scanning electrode 7 is a process which withstands a very high voltage (approximately 38 V) and requires a four-value level output. However, in this improved display panel, since the modulating electrode 8 for applying the modulating signal  $V_f$  is provided separately from the scanning electrode 7, the amplitude of the scanning signal  $V_g$  output from the output IC is greatly reduced to approximately 2 V and the level output is binary, so that the area of the IC chip is greatly reduced. As a result, the cost of the IC is greatly reduced. With respect to the modulating signal  $V_f$ , the amplitude is approximately 11 V.

**[0028]** Moreover, by forming the auxiliary capacitance 5 not between the pixel electrode 3 and the scanning

electrode 7 like in the conventional structure but between the pixel electrode 3 and the modulating electrode 8 provided below the pixel electrode 3 with the light transmitting insulating film 12 between as shown in Fig. 2(b), the load capacitance of the scanning electrode 7 is reduced, so that the width of the scanning electrode 7 can be reduced to significantly improve the numerical aperture.

#### 10 Embodiment

**[0029]** FIG. 4 is a circuit diagram showing the structure of a liquid crystal display panel according to an embodiment of the present invention. In FIG. 4, reference numeral 2 represents a TFT, reference numeral 3 represents a pixel electrode, reference numeral 4 represents a liquid crystal capacitance, reference numeral 5 represents an auxiliary capacitance, reference numeral 6 represents a counter electrode, reference numeral 7 represents a scanning electrode, reference numeral 8 represents a modulating electrode, and reference numeral 9 represents a signal electrode. These elements are similar to those of the previously described liquid crystal panel and denoted by the same reference numerals as those of FIG. 1. In FIG. 4, pixels in odd-numbered columns are denoted by 1 and pixels in even-numbered columns are denoted by 10.

**[0030]** The embodiment is similar to the previously described liquid crystal panel in that the modulating electrode 8 for applying the modulating signal  $V_f$  to modulate the potential  $V_d$  of the pixel electrode 3 through the auxiliary capacitance 5 is provided separately from the scanning electrode 7. In the embodiment, the auxiliary capacitances 5 in the pixels 1 in odd-numbered columns and those in the pixels 10 in even-numbered columns are connected to the modulating electrodes 8 in different rows. Therefore, the number of modulating electrodes 8 is greater by one than the number of scanning electrodes 7. The polarity of the image signal  $V_s$  supplied to the signal electrodes 9 in odd-numbered columns and that supplied to the electrodes 9 in even-numbered columns are opposite to each other.

**[0031]** The structure of the auxiliary capacitance 5 in the embodiment is shown in FIGs. 5(a) and 5(b). FIG. 5 (a) is a plan view showing the structure of the auxiliary capacitance 5. FIG. 5(b) is a cross-sectional view taken on the line B-B of FIG. 5(a). In these figures, the TFT 2 is not illustrated but shown being simplified. As shown in the figures, the auxiliary capacitance 5 is formed by providing the modulating electrode 8, with a light transmitting insulating film 12 between, below the pixel electrode 3 disposed on the light transmitting substrate 11. Therefore, after the modulating electrode 8 is formed on the light transmitting substrate 11, the light transmitting insulating film 12 is formed on the entire surface, and the pixel electrode 3, the scanning electrode 7 and the signal electrode 9, etc. are formed on the light transmitting insulating film 12. The elements such as the pixel

electrode 3, the modulating electrode 8, the light transmitting substrate 11 and the light transmitting insulating film 12 are made of a similar material to those of the previously described liquid crystal panel. The embodiment is different therefrom in the plane configuration of the modulating electrode 8.

**[0032]** FIG. 6 is an equivalent circuit diagram of the pixel (i, j) of the liquid crystal display panel according to the embodiment of the present invention when the TFT 2 is off. In FIG. 6, Cgd represents a gate-drain capacitance between the gate electrode and the drain electrode of the TFT 2, and Csd<sub>1</sub> and Csd<sub>2</sub> represent signal electrode-pixel electrode capacitances between the signal electrode 9 and the pixel electrode 3.

**[0033]** FIGs. 7 (a) to 7(b) are signal waveform charts of the liquid crystal display panel according to the embodiment. FIG. 7(a) is a signal waveform chart at the pixel (i, j). FIG. 7(b) is a signal waveform chart at the pixel (i+1, j). FIG. 7(c) is a signal waveform chart at the pixel (i+2, j). FIG. 7(d) is a signal waveform chart at a pixel (i, j+1). FIG. 7(e) is a signal waveform chart at a pixel (i+1, j+1). FIG. 7(f) is a signal waveform chart at a pixel (i+2, j+1). In these figures, 1H represents a horizontal scanning period, 1V represents a vertical scanning period, Vc represents a counter signal, Vg represents a scanning signal, Vs represents an image signal, Vd represents the potential of the pixel electrode 3, Vf represents a modulating signal, Vge+ represents a positive modulating voltage, and Vge- represents a negative modulating voltage.

**[0034]** The application period of the modulating voltages Vge+ and Vge- is shifted by the 1H period between FIGs. 7(a) to (c) and 7(d) to 7(f). With respect to the pixels in the j-th column, the auxiliary capacitance 5 of, for example, the pixel (i, j) in the i-th row is connected to the modulating electrode 8 in the i-th row, whereas with respect to the pixels in the (j+1)-th column, the auxiliary capacitance 5 of, for example, the pixel (i, j+1) in the i-th row is connected to the modulating electrode 8 in the (i+1)-th row. The modulating electrode 8 in the (i+1)-th row is the modulating electrode 8 connected to the auxiliary capacitance 5 of the pixel (i+1, j) in the (i+1)-th row among the pixels in the j-th column. Thus, in the pixels in odd-numbered columns and the pixels in even-numbered columns, a common modulating electrode 8 is used as the auxiliary capacitances of pixels in rows different from each other by one row, so that a shift of the 1H period is caused during the application period of the modulating voltages Vge+ and Vge-. However, this does not cause a large problem because it is a shift of the 1H period during the 1V period.

**[0035]** With respect to the liquid crystal display panel according to the embodiment thus structured, an operation thereof will be described.

**[0036]** First, the case of the pixels 1 in odd-numbered column will be described. For example, at the pixel (i, j), when the scanning signal Vg(i) is on for the 1H period, the image signal Vs(j) is supplied to the pixel electrode

3 serving as one of the electrodes of the liquid crystal capacitance 4 and the auxiliary capacitance 5, so that a predetermined voltage is reached. When the scanning signal Vg(i) becomes off, it is attempted to maintain the voltage for the 1V period; however, since the auxiliary capacitance 5 is connected to the modulating electrode 8, when the modulating signal Vf(i) changes to the positive modulating voltage Vge+ or to the negative modulating voltage Vge-, the potential Vd(i, j) of the pixel electrode 3 changes accordingly. Thus, an effective voltage as well as the image signal Vs(j) is applied to the liquid crystal capacitance 4. The same is performed at the pixel (i+1, j) and at the pixel (i+2, j), etc.

**[0037]** Next, the case of the pixels 10 in even-numbered columns will be described. For example, at the pixel (i, j+1), when the scanning signal Vg(i) is on for the 1H period, a reversed image signal/Vs(j+1) is supplied to the pixel electrode 3 serving as one of the electrodes of the liquid crystal capacitance 4 and the auxiliary capacitance 5, so that a predetermined voltage is reached. When the scanning signal Vg(i) becomes off, it is attempted to maintain the voltage for the 1V period; however, since the auxiliary capacitance 5 is connected to the modulating electrode 8, when the modulating signal Vf(i+1) changes to the positive modulating voltage Vge+ or to the negative modulating voltage Vge-, the potential Vd(i, j+1) of the pixel electrode 3 changes accordingly. Thus, an effective voltage as well as the reversed image signal/Vs(j+1) is applied to the liquid crystal capacitance 4. The same is performed at the pixel (i+1, j+1) and at the pixel (i+2, j+1), etc., so that an image is displayed on the entire screen.

**[0038]** As described above, according to the embodiment, by providing the modulating electrode 8 for applying the modulating signal Vf separately from the scanning electrode 7, the amplitude of the scanning signal Vg output from the output IC is greatly reduced and the level output is binary, so that the area of the IC chip is greatly reduced. As a result, the cost of the IC is greatly reduced.

**[0039]** Moreover, by forming the auxiliary capacitance 5 not between the pixel electrode 3 and the scanning electrode 7 like in the conventional display panel but between the pixel electrode 3 and the modulating electrode 8 provided below the pixel electrode 3 with the light transmitting insulating film 12 between as shown in FIGs. 5(a) and 5(b), the load capacitance of the scanning electrode 7 is reduced, so that the width of the scanning electrode 7 can be reduced to significantly improve the numerical aperture.

**[0040]** Further, according to the embodiment, since the auxiliary capacitance 5 connected to the pixel electrode 3 is formed between the pixel electrode 3 and a modulating electrode 8 which differs for each column and the polarity of the image signal Vs applied to the signal electrodes 9 in odd-numbered columns and that applied to the electrodes 9 in even-numbered columns are opposite to each other, the potentials Vd of the pixel

electrodes 3 are swung so as to cancel each other through adjoining signal electrode-pixel electrode capacitances  $Csd_1$  and  $Csd_2$ , so that the potentials  $V_d$  of the pixel electrodes 3 are not swung but become stable. As a result, crosstalk disappears and the display quality is significantly improved.

**[0041]** While the scanning signal  $V_g$ , the image signal  $V_s$  and the modulating signal  $V_f$  are supplied to the electrodes in the description given above, the present invention can be embodied when these signals are all generated in an incorporated IC and supplied or are separately generated in an external IC and supplied.

**[0042]** While description has been given with respect to the pixel-by-pixel structure in the embodiment, similar effects are obtained in the case of a structure per RGB.

**[0043]** Conventionally, a modulating voltage for modulating the potential of a pixel electrode through an auxiliary capacitance is superimposed on a scanning signal and applied to a scanning electrode. On the contrary, modulating electrodes for applying a modulating voltage are provided separately from the scanning electrodes. Consequently, the amplitude of the scanning signal output from the output IC so as to be applied to the scanning electrode is greatly reduced and the level output is binary, so that the area of the IC chip is greatly reduced. As a result, the cost of the IC is greatly reduced. Moreover, since a modulating electrode is provided below the pixel electrode and no auxiliary capacitance is formed between the pixel electrode and the scanning electrode, the load capacitance of the scanning electrode is reduced, so that the width of the scanning electrode can be reduced to significantly improve the numerical aperture.

## Claims

1. A liquid crystal display panel in which a plurality of pixel electrodes (3) are arranged in  $m$  rows and in  $n$  columns on a light transmitting substrate,  $m$  rows of scanning electrodes (7) and  $n$  columns of signal electrodes (9) are perpendicularly arranged between said plurality of pixel electrodes, a thin film transistor (2) in which a gate electrode is connected to a scanning electrode in an  $i$ -th row,  $i$  being an integer among 1 to  $m$ , a source electrode is connected to a signal electrode in a  $j$ -th column,  $j$  being an integer among 1 to  $n$ , and a drain electrode is connected to a pixel electrode in the  $i$ -th row in the  $j$ -th column is disposed at each intersection of said scanning electrode and said signal electrode, a counter electrode (6) which is opposed to said pixel electrode with liquid crystal between is disposed, and a modulating electrode arrangement is provided, between which and said pixel electrodes auxiliary capacitances (5) are formed, **characterised in that** the following modulating electrodes (8) are provided:

a modulating electrode in a first row between which and said pixel electrode in the first row in a  $p$ -th column,  $p$  being an odd number or an even number among 1 to  $n$ , an auxiliary capacitance is formed; a modulating electrode in a  $k$ -th row between which and said pixel electrode in a  $k$ -th row in the  $p$ -th column,  $k$  being an integer among 2 to  $m$ , and in the  $(k-1)$ -th row in a  $q$ -th column,  $q$  being an integer other than  $p$  among 1 to  $n$ , the auxiliary capacitance is formed; and a modulating electrode in an  $(m+1)$ -th row between which and said pixel electrode in the  $m$ -th row in the  $q$ -th column, the auxiliary capacitance is formed.

2. A liquid crystal display panel according to claim 1, wherein said modulating electrodes in the first to the  $(m+1)$ -th rows are formed by use of a light transmitting conductive material, said modulating electrode in the first row is provided between the pixel electrode in the first row in the  $p$ -th column and the light transmitting substrate with a light transmitting insulating film between the pixel electrode in the first row in the  $p$ -th column and the modulating electrode in the first row, said modulating electrode in the  $k$ -th row is provided between the pixel electrodes in the  $k$ -th row in the  $p$ -th column and in the  $(k-1)$ -th row in the  $q$ -th column and the light transmitting substrate with the light transmitting insulating film between the pixel electrodes in the  $k$ -th row in the  $p$ -th column and in the  $(k-1)$ -th row in the  $q$ -th column and the modulating electrode in the  $k$ -th row, and said modulating electrode in the  $(m+1)$ -th row is provided between the pixel electrode in the  $m$ -th row in the  $q$ -th column and the light transmitting substrate with the light transmitting insulating film between the pixel electrode in the  $m$ -th row in the  $q$ -th column and the modulating electrode in the  $(m+1)$ -th row.
3. A method of driving the liquid crystal display panel according to claim 1 or 2, wherein a potential of the pixel electrode is controlled through the auxiliary capacitance by supplying to the signal electrodes image signals whose polarity is reversed at every column of the  $n$  columns of the signal electrodes, the polarity of the image signal applied to each signal electrode being reversed every horizontal scanning period, and applying a positive modulating voltage and a negative modulating voltage to each modulating electrode.

## Patentansprüche

1. Flüssigkristallanzeige, bei der eine Vielzahl von Pixelelektroden (3) in  $m$  Zeilen und in  $n$  Spalten auf einem lichtdurchlässigen Substrat angeordnet sind,  $m$  Zeilen von Abtastelektroden (7) und  $n$  Spalten von Signalelektroden (9) senkrecht zwischen der

Vielzahl von Pixelelektroden angeordnet sind, ein Dünnschichttransistor (2), bei dem eine Gate-Elektrode mit einer Abtastelektrode in einer i-ten Zeile verbunden ist, wobei i eine ganze Zahl zwischen 1 und m ist, eine Source-Elektrode mit einer Signalelektrode in einer j-ten Spalte verbunden ist, wobei j eine ganze Zahl zwischen 1 und n ist, und eine Drain-Elektrode mit einer Pixelelektrode in einer i-ten Zeile in der j-ten Spalte bei jeder Kreuzung der Abtastelektrode mit der Signalelektrode angeordnet ist, eine Gegenlektrode (6), die gegenüber der Pixelelektrode angeordnet ist, mit Flüssigkristall dazwischen angeordnet ist, und bei der eine Modulationselektrodenanordnung vorgesehen ist, zwischen der und den Pixelelektroden zusätzliche Kondensatoren (5) gebildet sind,

**dadurch gekennzeichnet,**

**daß** die folgenden Modulationselektroden (8) vorgesehen sind: eine Modulationselektrode in einer ersten Zeile, zwischen der und der Pixelelektrode in der ersten Zeile in einer p-ten Spalte, wobei p ungeradzahlig oder geradzahlig ist als eine Zahl zwischen 1 und n, eine Zusatzkapazität gebildet ist; eine Modulationselektrode in einer k-ten Zeile, zwischen der und der Pixelelektrode in einer k-ten Zeile in der p-ten Spalte, wobei k eine ganze Zahl zwischen 2 und m ist, und die (k-1)-te Zeile in einer q-ten Spalte, wobei q eine andere ganze Zahl als p zwischen 1 und n ist, die Zusatzkapazität gebildet ist; und eine Modulationselektrode in einer (m+1)-ten Zeile zwischen der Pixelelektrode in der m-ten Zeile in der q-ten Spalte der Zusatzkapazität gebildet ist.

2. Flüssigkristallanzeige nach Anspruch 1, bei der die Modulationselektroden in der ersten bis zur (m+1)-ten Zeile gebildet sind unter Verwendung eines lichtdurchlässigen leitfähigen Materials, wobei die Modulationselektrode in der ersten Zeile vorgesehen ist zwischen der Pixelelektrode in der ersten Zeile in der p-ten Spalte und dem lichtdurchlässigen Substrat mit einem lichtdurchlässigen Isolationsfilm zwischen der Pixelelektrode in der ersten Zeile in der p-ten Spalte und der Modulationselektrode in der ersten Zeile, wobei die Modulationselektrode in der k-ten Zeile vorgesehen ist zwischen den Pixelelektroden in der k-ten Zeile in der p-ten Spalte und in der (k-1)-ten Zeile in der q-ten Spalte und dem lichtdurchlässigen Substrat mit dem lichtdurchlässigen Isolationsfilm zwischen den Pixelelektroden in der k-ten Zeile in der p-ten Spalte und in der (k-1)-ten Zeile in der q-ten Spalte und der Modulationselektrode in der k-ten Zeile, und bei der die Modulationselektrode in der (m+1)-ten Zeile zwischen der Pixelelektrode vorgesehen ist in der m-ten Zeile in der q-ten Spalte und das lichtdurchlässige Substrat mit dem lichtdurchlässigen Isolationsfilm zwischen der Pixelelektrode in der m-ten Zeile in der

q-ten Spalte und der Modulationselektrode in der (m+1)-ten Zeile.

3. Verfahren zum Steuern der Flüssigkristallanzeige nach Anspruch 1 oder 2, bei dem ein Potential der Pixelelektrode gesteuert wird durch die Zusatzkapazität durch Liefern von Bildsignalen an die Signalelektroden, wobei die Polarität der Bildsignale bei jeder Spalte der n Spalten der Signalelektroden umgepolt ist, wobei die Polarität des an jede Signalelektrode angelegten Bildsignals bei jeder Horizontalabtastperiode umgepolt ist, und durch Anlegen einer positiven Modulationsspannung und einer negativen Modulationsspannung an jede Modulationselektrode.

### Revendications

1. Panneau d'affichage à cristaux liquides dans lequel une pluralité d'électrodes de pixels (3) sont disposées dans m rangées et dans n colonnes sur un substrat de transmission de lumière, m rangées d'électrodes de balayage (7) et n colonnes d'électrodes de signaux (9) sont disposées perpendiculairement entre ladite pluralité d'électrodes de pixels, un transistor à couche mince (2) dans lequel une électrode de grille est reliée à une électrode de balayage dans une  $i^{\text{ème}}$  rangée, i étant un nombre entier de 1 à m, une électrode de source est reliée à une électrode de signal dans une  $j^{\text{ème}}$  colonne, j étant un nombre entier de 1 à n, et une électrode de drain qui est reliée à une électrode de pixel dans la  $i^{\text{ème}}$  rangée de la  $j^{\text{ème}}$  colonne est disposée à chaque intersection de ladite électrode de balayage et de ladite électrode de signal, une contre électrode (6) qui est opposée à ladite électrode de pixel, des cristaux liquides étant disposés entre les deux, et un agencement d'électrodes de modulation est prévu, entre lequel et lesdites électrodes de pixels des capacités auxiliaires (5) sont formées,

**caractérisé en ce que** les électrodes de modulation suivantes (8) sont prévues : une électrode de modulation dans une première rangée entre laquelle et ladite électrode de pixel de la première rangée dans une  $p^{\text{ème}}$  colonne, p étant un nombre impair ou un nombre pair de 1 à n, une capacité auxiliaire est formée, une électrode de modulation dans une  $k^{\text{ème}}$  rangée entre laquelle et ladite électrode de pixel d'une  $k^{\text{ème}}$  rangée de la  $p^{\text{ème}}$  colonne, k étant un nombre entier de deux à m, et dans la  $(k - 1)^{\text{ème}}$  rangée dans une  $q^{\text{ème}}$  colonne, q étant un nombre entier autre que p, de 1 à n, la capacité auxiliaire est formée, et une électrode de modulation dans une  $(m + 1)^{\text{ème}}$  rangée entre laquelle et ladite électrode de pixel de la  $m^{\text{ème}}$  rangée dans la  $q^{\text{ème}}$  colonne, la capacité auxiliaire est formée.

2. Panneau d'affichage à cristaux liquides selon la revendication 1, dans lequel lesdites électrodes de modulation dans les premières à  $(m + 1)^{\text{ème}}$  rangées sont formées grâce à l'utilisation d'un matériau conducteur transmettant la lumière, ladite électrode de modulation de la première rangée est prévue entre l'électrode de pixel de la première rangée de la  $p^{\text{ème}}$  colonne et le substrat de transmission de lumière, avec un film isolant transmettant la lumière entre l'électrode de pixel de la première rangée de la  $p^{\text{ème}}$  colonne et l'électrode de modulation de la première rangée, ladite électrode de modulation dans la  $k^{\text{ème}}$  rangée est prévue entre les électrodes de pixels dans la  $k^{\text{ème}}$  rangée dans la  $p^{\text{ème}}$  colonne et dans la  $(k - 1)^{\text{ème}}$  rangée de la  $q^{\text{ème}}$  colonne et le substrat transmettant la lumière avec le film isolant transmettant la lumière entre les électrodes de pixels dans la  $k^{\text{ème}}$  rangée dans la  $p^{\text{ème}}$  colonne et dans la  $(k-1)^{\text{ème}}$  rangée de la  $q^{\text{ème}}$  colonne et l'électrode de modulation dans la  $k^{\text{ème}}$  rangée, et ladite électrode de modulation dans la  $(m + 1)^{\text{ème}}$  rangée est prévue entre l'électrode de pixel dans la  $m^{\text{ème}}$  rangée dans la  $q^{\text{ème}}$  colonne et le substrat transmettant la lumière, avec le film isolant transmettant la lumière entre l'électrode de pixel dans la  $m^{\text{ème}}$  rangée dans la  $q^{\text{ème}}$  colonne et l'électrode de modulation dans la  $(m + 1)^{\text{ème}}$  rangée.
3. Procédé d'attaque du panneau d'affichage à cristaux liquides selon la revendication 1 ou 2, dans lequel un potentiel de l'électrode de pixel est commandé par l'intermédiaire de la capacité auxiliaire en appliquant aux électrodes de signal des signaux image dont la polarité est inversée à chaque colonne des  $n$  colonnes des électrodes de signaux, la polarité du signal d'image appliquée à chaque électrode de signal étant inversée à chaque période de balayage horizontal et appliquant une tension de modulation positive et une tension de modulation négative à chaque électrode de modulation.

45

50

55

Fig. 1

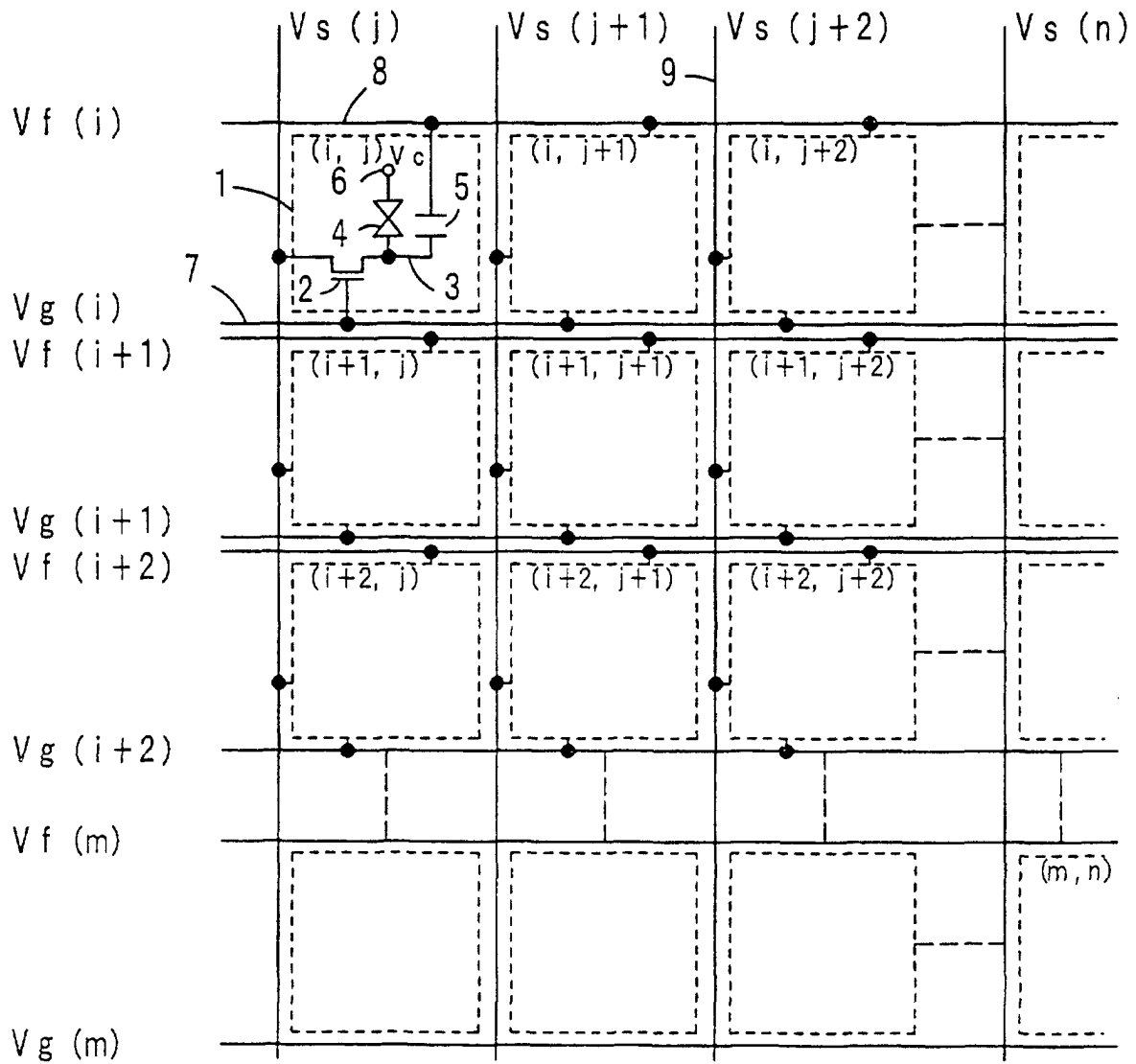
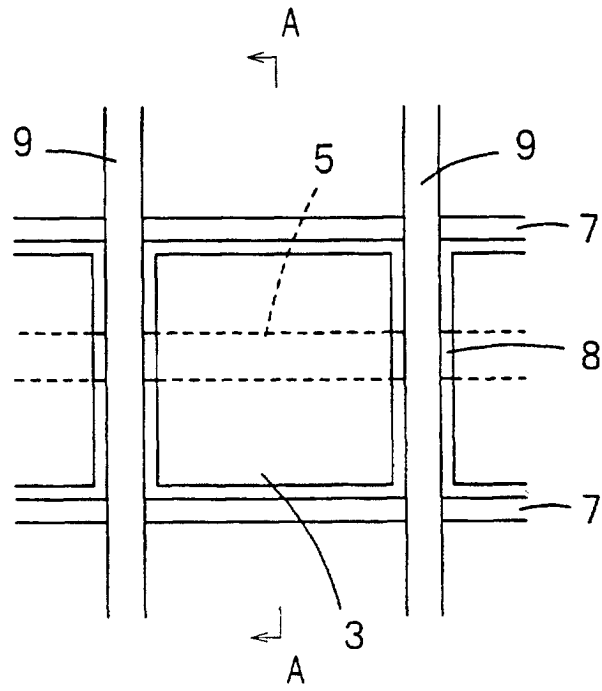

Fig. 2

(a)



(b)

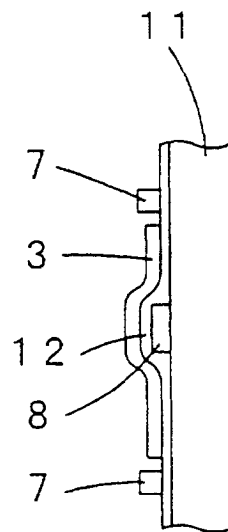

Fig. 3

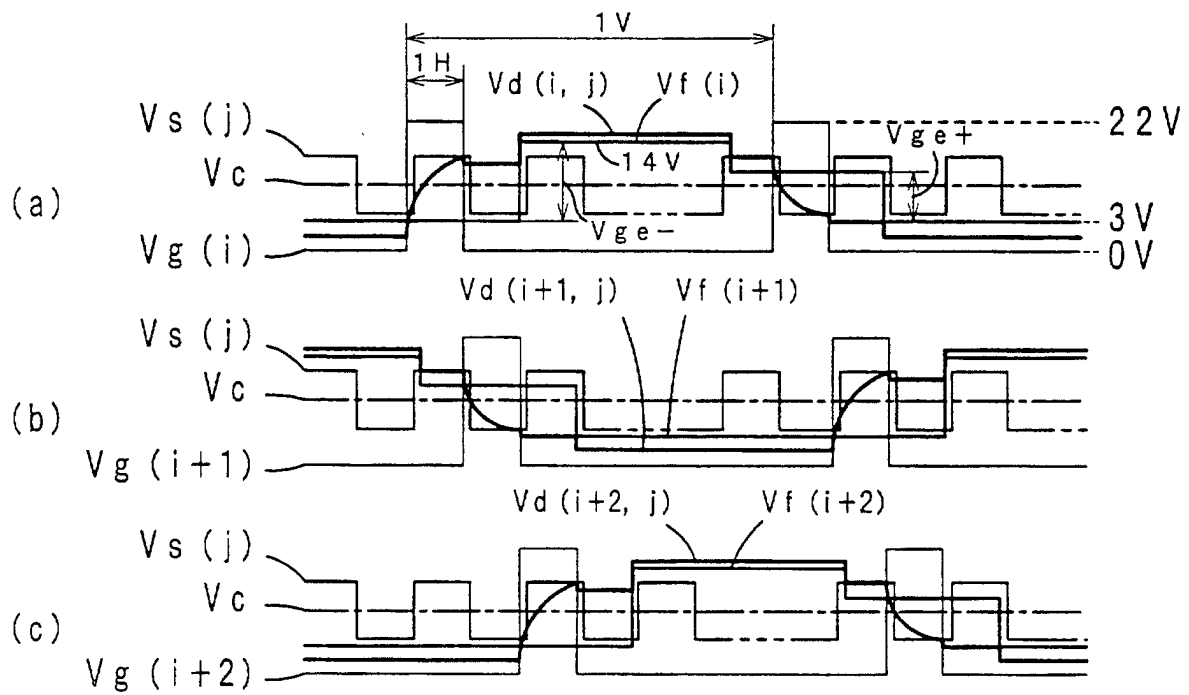

Fig. 4

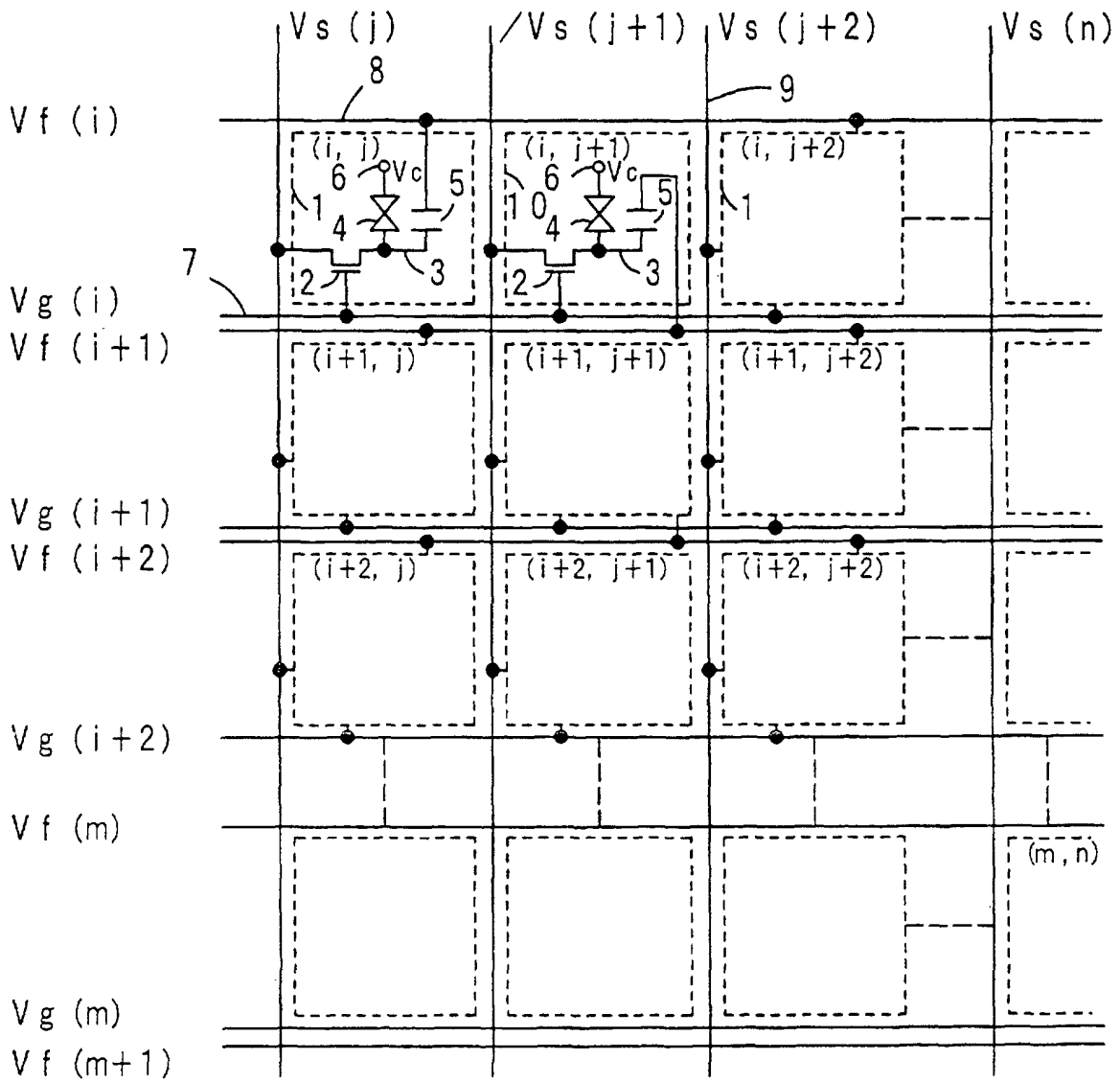
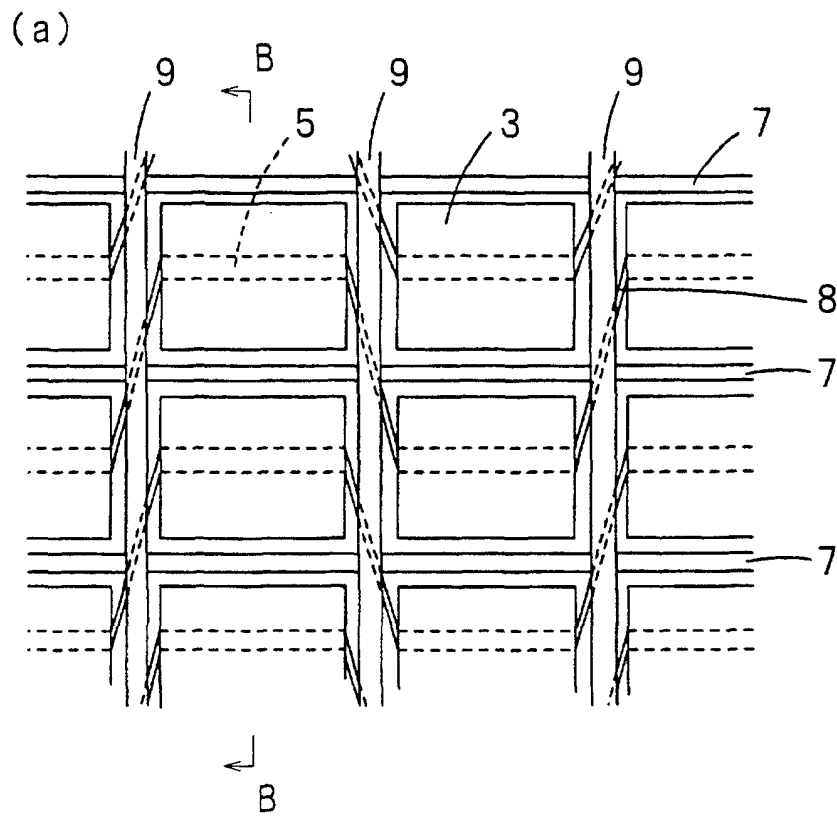

Fig. 5



(b)

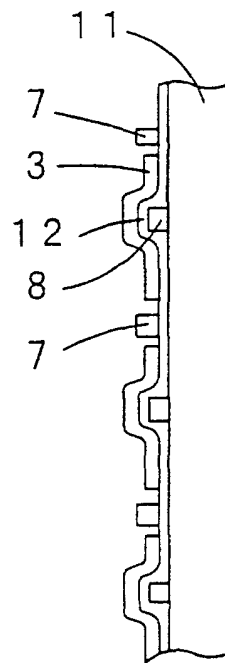

Fig. 6

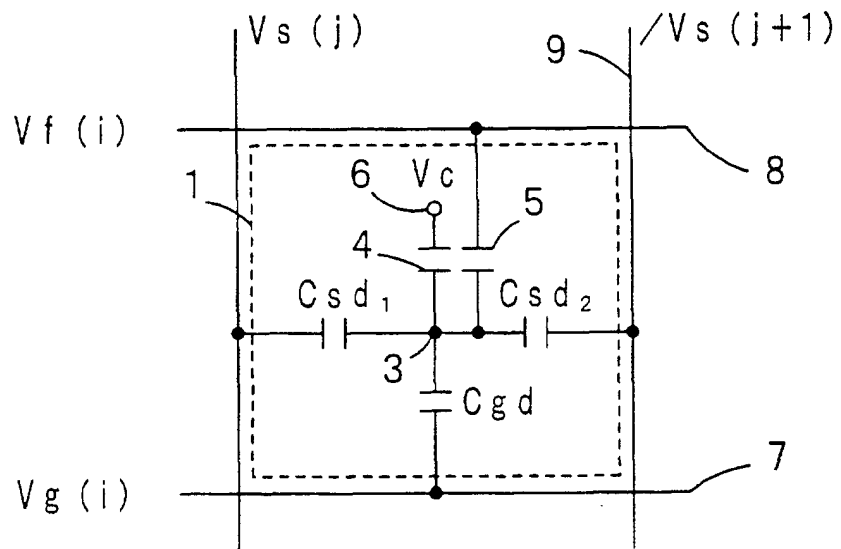

Fig. 7

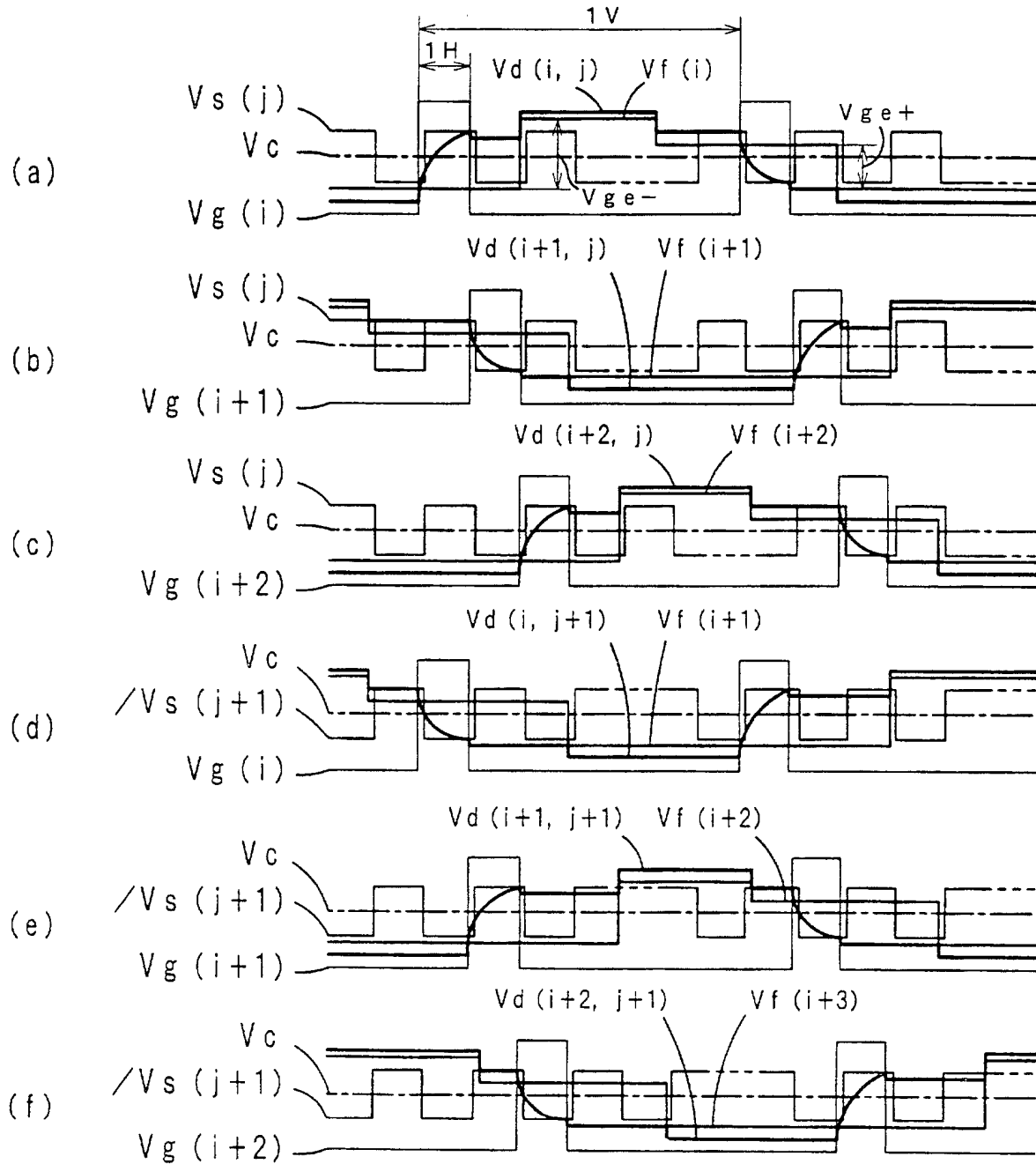

Fig. 8

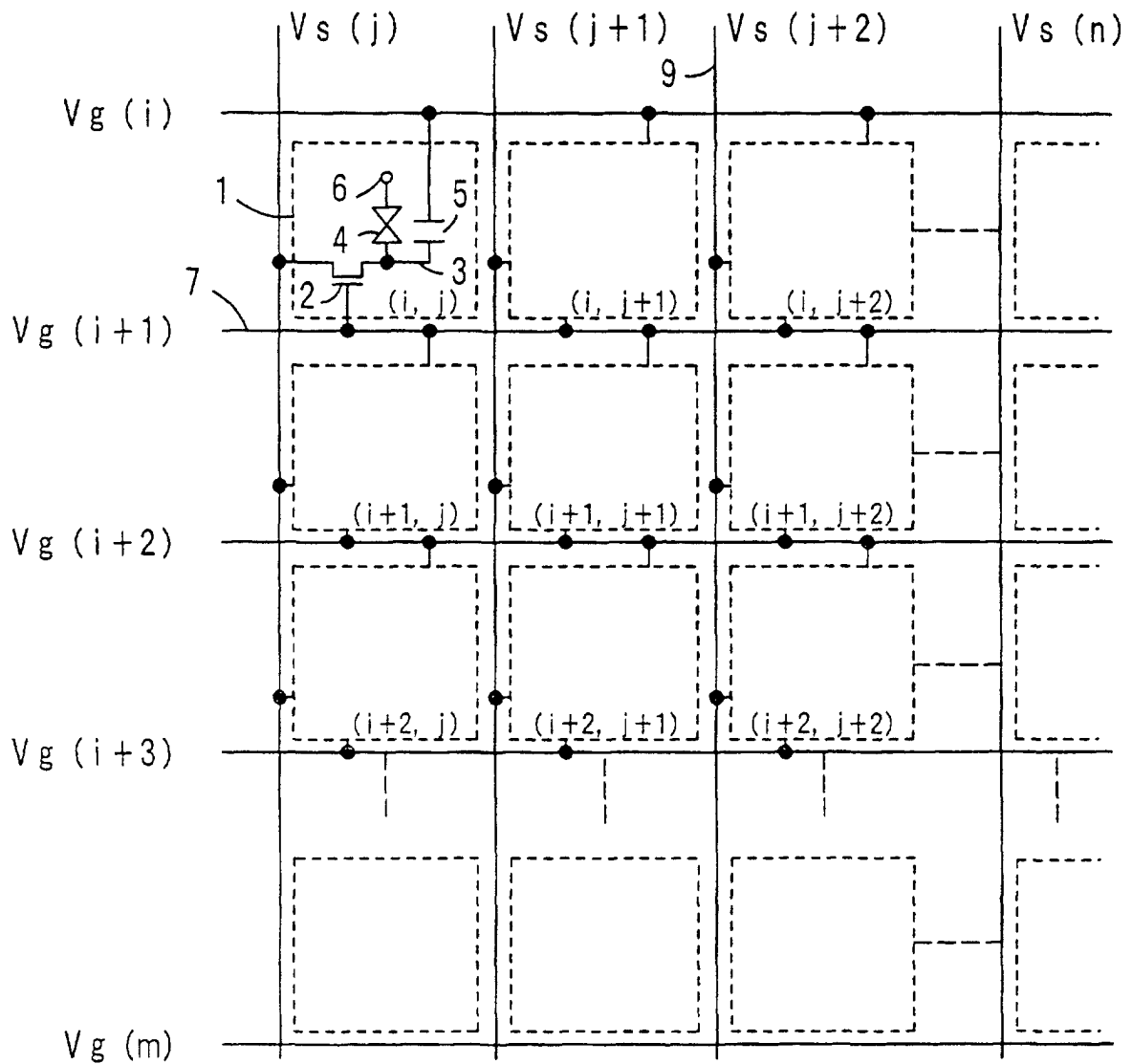

Fig. 9

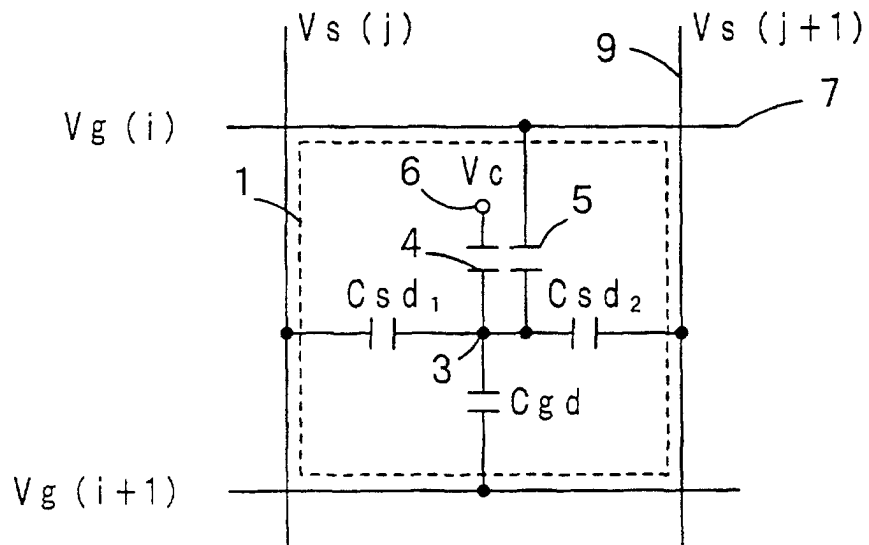



Fig. 11

