



- (51) International Patent Classification: *G01V 3/30* (2006.01) *G01V 3/38* (2006.01)
- (21) International Application Number: PCT/RU2011/000528
- (22) International Filing Date: 18 July 2011 (18.07.2011)
- (25) Filing Language: English
- (26) Publication Language: English
- (71) Applicant (for all designated States except US): **BAKER HUGHES INCORPORATED** [US/US]; P.O. Box 4740, Houston, Texas 77210-4740 (US).
- (72) Inventors; and
- (71) Applicants (for RU, US only): **DOROVSKY, Vitaly Nikolaevich** [RU/RU]; Krasniy prospect, 73-51, Novosibirsk, 630091 (RU). **GAPEYEV, Denis Nikolaevich** [RU/RU]; ul. Geroev Truda, 22-2, Novosibirsk, 630055 (RU). **ELTSOV, Timofey Igorevich** [RU/RU]; ul. Lesosechnaya, 7-264, Novosibirsk, 630060 (RU).
- (74) Agents: **VESELITSKIY, Maxim Borisovich** et al.; M. Zlatoustinsky per., 10-15, Moscow, 101000 (RU).
- (81) Designated States (unless otherwise indicated, for every kind of national protection available): AE, AG, AL, AM, AO, AT, AU, AZ, BA, BB, BG, BH, BR, BW, BY, BZ, CA, CH, CL, CN, CO, CR, CU, CZ, DE, DK, DM, DO, DZ, EC, EE, EG, ES, FI, GB, GD, GE, GH, GM, GT, HN, HR, HU, ID, IL, IN, IS, JP, KE, KG, KM, KN, KP, KR, KZ, LA, LC, LK, LR, LS, LT, LU, LY, MA, MD, ME, MG, MK, MN, MW, MX, MY, MZ, NA, NG, NI, NO, NZ, OM, PE, PG, PH, PL, PT, RO, RS, RU, SC, SD, SE, SG, SK, SL, SM, ST, SV, SY, TH, TJ, TM, TN, TR, TT, TZ, UA, UG, US, UZ, VC, VN, ZA, ZM, ZW.
- (84) Designated States (unless otherwise indicated, for every kind of regional protection available): ARIPO (BW, GH, GM, KE, LR, LS, MW, MZ, NA, SD, SL, SZ, TZ, UG, ZM, ZW), Eurasian (AM, AZ, BY, KG, KZ, MD, RU, TJ, TM), European (AL, AT, BE, BG, CH, CY, CZ, DE, DK, EE, ES, FI, FR, GB, GR, HR, HU, IE, IS, IT, LT, LU, LV, MC, MK, MT, NL, NO, PL, PT, RO, RS, SE, SI, SK, SM,

[Continued on next page]

(54) Title: FINDING OIL CONTENT OF THE FORMATION USING DIELECTRIC SPECTROSCOPY

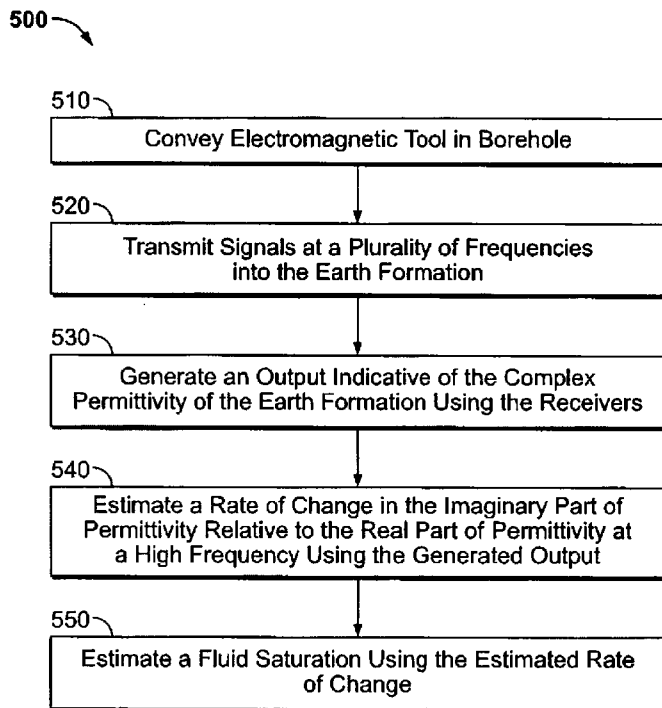
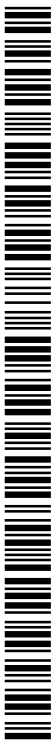

FIG. 5

(57) Abstract: The present disclosure relates to methods and apparatuses for evaluating fluid saturation in an earth formation using complex dielectric permittivity. The method may include estimating fluid saturation using an estimated rate of change at a frequency of an imaginary part of permittivity relative to a real part of permittivity. The method may include performing dielectric permittivity estimates using an electromagnetic tool in a borehole. The apparatus may include the electromagnetic tool and at least one processor configured to store information obtained by the electromagnetic tool in a memory. The at least one processor may also be configured to estimate the fluid saturation.



TR), OAPI (BF, BJ, CF, CG, CI, CM, GA, GN, GQ, GW, ML, MR, NE, SN, TD, TG). **Published:**

— with international search report (Art. 21(3))

FINDING OIL CONTENT OF THE FORMATION USING DIELECTRIC SPECTROSCOPY

BACKGROUND OF THE DISCLOSURE

5 1. Field of the Disclosure

This disclosure generally relates to exploration and production of hydrocarbons involving investigations of regions of an earth formation penetrated by a borehole. More specifically, the disclosure relates to the dielectric spectroscopy of an earth formation using a logging tool in a borehole.

10 2. Description of the Related Art

Electrical earth borehole logging is well known to persons having an ordinary level of skill in the art, and various devices and various techniques have been described for this purpose. Broadly speaking, there are two categories of electrical logging apparatus. In the first category, one or more measurement electrodes – current
15 source(s) or sink(s) – are used in conjunction with a return electrode (which may be a diffuse electrode such as a logging tool's body or mandrel). A measurement current flows in a circuit that connects a current source to the measurement electrode(s), through the earth formation to the return electrode, and back to the current source in the tool. In a second category, that of inductive measuring tools, an antenna within
20 the measuring instrument induces a current flow within the earth formation. The magnitude of the induced current is detected using either the same antenna or a separate receiver antenna. The present disclosure belongs to the second category.

SUMMARY OF THE DISCLOSURE

25 In view of the foregoing, the present disclosure is directed to a method and apparatus for estimating fluid saturation using dielectric spectroscopy of subterranean formations penetrated by a borehole.

One embodiment according to the present disclosure includes a method of evaluating an earth formation, the method comprising: estimating a fluid saturation in the earth formation using an estimated rate of change at a high frequency of an
30 imaginary part of a permittivity of the earth formation relative to a real part of the permittivity of the earth formation, where the imaginary part and the real part are based on measurements using an electromagnetic tool at a plurality of frequencies in a borehole penetrating the earth formation.

Another embodiment according to the present disclosure includes an apparatus for evaluating an earth formation, the apparatus comprising: a carrier configured to be conveyed in a borehole penetrating the earth formation; a electromagnetic tool disposed on the carrier and configured to make measurements indicative of an imaginary part and a real part of a permittivity of the earth formation at a plurality of frequencies; and at least one processor configured to: estimate the imaginary part and the real part at the plurality of frequencies by inventing the measurements, and estimate a rate of change at a high frequency of the imaginary part relative to the real part.

Another embodiment according to the present disclosure includes a computer-readable medium product having instructions thereon that, when executed, cause at least one processor to perform a method, the method comprising: estimating a fluid saturation in an earth formation using an estimated rate of change at a high frequency of an imaginary part of a permittivity of the earth formation relative to a real part of the permittivity of the earth formation, where the imaginary part and the real part are based on measurements using an electromagnetic tool at a plurality of frequencies in a borehole penetrating the earth formation.

BRIEF DESCRIPTION OF THE DRAWINGS

The present disclosure is best understood with reference to the accompanying figures in which like numerals refer to like elements and in which like numerals refer to like elements and in which:

FIG. 1 is a schematic of a drilling site including an electromagnetic tool for estimating a parameter in an earth formation according to one embodiment of the present disclosure;

FIG. 2A is a schematic view of an electromagnetic tool in accordance with one embodiment of the present disclosure;

FIG. 2B is a schematic view of a pad of an electromagnetic tool in accordance with one embodiment of the present disclosure;

FIG. 3A is a schematic of an antenna configuration for a pad of an electromagnetic tool for one embodiment according to the present disclosure;

FIG. 3B is a schematic of an antenna configuration for a pad of an electromagnetic tool for another embodiment according to the present disclosure;

FIG. 4A is a schematic of an antenna configuration for a pad of an

electromagnetic tool for another embodiment according to the present disclosure;

FIG. 4B is a schematic of an antenna configuration for a pad of an electromagnetic tool for another embodiment according to the present disclosure;

FIG. 5 is a flow chart for a method for one embodiment according to the present disclosure;

FIG. 6 is a set of graphs showing relaxations for different polarization types for one embodiment according to the present disclosure;

FIG. 7 is a graph of complex permittivity for water and water/oil saturated sandstone for one embodiment according to the present disclosure;

FIG. 8 is a graph of imaginary versus real parts of complex permittivity for water and water/oil saturated sandstone for one embodiment according to the present disclosure; and

FIG. 9 is a graph of imaginary versus real parts of complex permittivity for water and water/oil saturated sandstone with different probe lengths for one embodiment according to the present disclosure.

DETAILED DESCRIPTION OF THE DISCLOSURE

In the disclosure that follows, in the interest of clarity, not all features of actual implementations are described. It will of course be appreciated that in the development of any such actual implementation, as in any such project, numerous engineering and technical decisions must be made to achieve the developers' specific goals and subgoals (e.g., compliance with system and technical constraints), which will vary from one implementation to another. Moreover, attention will necessarily be paid to proper engineering and programming practices for the environment in question. It will be appreciated that such development efforts may be complex and time-consuming, outside the knowledge base of typical laymen, but would nevertheless be a routine undertaking for those of ordinary skill in the relevant fields.

Dielectric spectroscopy includes the estimation of electric permittivity of materials. Electric permittivity may include imaginary and real parts, which may vary with the frequency of an electrical signal exposed to a material. In some aspects, electric permittivity may be estimated using an electromagnetic tool configured to generate an electric current at a plurality of frequencies.

In some aspects, the electromagnetic tool may include an inductive electromagnetic probe that may be electrically coupled to an earth formation from

inside of a borehole penetrating the earth formation. Dielectric permittivity may be obtained by solving Maxwell equations. For a homogeneous medium, the relationship between a magnetic field, H_z , and dielectric permittivity, ϵ , may be expressed as:

$$\begin{aligned}
 H_r^0 &= \frac{M_z r z}{4\pi R^5} (3 + 3kR + k^2 R^2) e^{-kR}, \\
 H_\phi^0 &= 0, \\
 H_z^0 &= -\frac{M_z}{4\pi R^3} \left(\frac{3r^2}{R^2} + \frac{3kr^2}{R} + k^2 R^2 - 2 - 2kR \right) e^{-kR}, \\
 R^2 &= r^2 + z^2, k^2 = -\omega^2 \mu \epsilon, \epsilon = \epsilon' + i\epsilon''
 \end{aligned}
 \tag{1}$$

5 where M_z is the receiver coil magnetic moment, k is a wave number, ω is a circular frequency, R is a radial distance, r and z are coordinates in the cylindrical coordinate system, μ is the permeability of the material, and ϵ' and ϵ'' are real and imaginary parts of dielectric permittivity. The dielectric permittivity may be estimated using methods known to those of skill in the art, including, but not limited to one or more of: (i) a Newton method and (ii) a Marquardt-Levenberg method.

The estimated imaginary and real parts of permittivity of the earth formation may be used to estimate at least one parameter of interest of the earth formation. The at least one parameter of interest may include, but is not limited to: (i) water saturation, (ii) oil saturation, and (iii) colloidal structure of a water-oil structure.

15 If, for example, a dipole antenna configured to emit electromagnetic waves is placed in the center of the borehole with a receiver antenna located in the borehole at a certain distance from the transmitter, then real and imaginary parts of the magnetic field may be measured by the receiver antenna. A spectral image of dielectric permittivity may be generated using the imaginary and real parts of permittivity over a plurality of frequencies. Each point on the spectral image of dielectric permittivity may correspond to a specific frequency in the electromagnetic spectrum. The bulk fractions of water and oil in the earth formation may be estimated using the spectral image of dielectric permittivity. Embodiments of apparatuses and methods for estimating these bulk fractions are discussed below.

25 **FIG. 1** shows an electromagnetic tool **10** suspended, in a borehole **12** penetrating earth formation **13**, from a suitable cable **14** that passes over a sheave **16** mounted on drilling rig **18**. By industry standard, the cable **14** includes a stress member and seven conductors for transmitting commands to the tool and for receiving

- 5 -

data back from the tool as well as power for the tool. The electromagnetic tool **10** is raised and lowered by draw works **20**. Electronic module **22**, on the surface **23**, transmits the required operating commands downhole and in return, receives data back which may be recorded on an archival storage medium of any desired type for concurrent or later processing. The data may be transmitted in analog or digital form. Data processors such as a suitable computer **24**, may be provided for performing data analysis in the field in real time or the recorded data may be sent to a processing center or both for post processing of the data. Some or all of the processing may also be done by using a downhole processor at a suitable location on the logging tool **10**. While a wireline conveyance system has been shown, it should be understood that embodiments of the present disclosure may be utilized in connection with tools conveyed via rigid carriers (e.g., jointed tubular or coiled tubing) as well as non-rigid carriers (e.g., wireline, slickline, e-line, etc.). Some embodiments of the present disclosure may be deployed along with LWD/MWD tools.

The electromagnetic tool **10** may include at least one transmitting antenna and at least two receiving loop antennas mounted on a pad. The tool may be operated in at least two modes. A first mode may be referred to as Mini-MPR (Multiple propagation resistivity) mode that may measure attenuation and a phase difference between the two receivers. The electromagnetic tool **10** may also be operated in a second mode (an induction mode) in which a compensated magnetic field (voltage) may be measured. The current in the transmitter coil may induce a magnetic field in the earth formation **13**. This magnetic field, in turn, may cause eddy currents to flow in the earth formation **13**. Because of the presence of these formation currents, a magnetic field may be coupled into a receiver coil R thereby generating a receiver signal. Logging tools having "a receiver coil" and "a transmitter coil" each comprised of several coils arranged in a predetermined fashion to obtain a desired response may be used. The receiver signal may then be amplified and applied to one or more phase sensitive detectors (PSDs). Each PSD may detect a phase component signal having a phase identical to a phase reference signal which may also be applied to the detector. The phase reference signal may have a predetermined phase relationship to the current in the transmitter coil(s). The output of the PSD(s) may be further processed downhole, or may be sent uphole to surface equipment for processing or display to an operating engineer.

- 6 -

In the induction mode, one receiver loop coil may serve as a main receiver and the other as a bucking receiver. The transmitting antennas may include loops and/or electric dipoles. For loop transmitter antennas, the transmitters and receivers may be in one of three orientations. If the z-axis of the tool is parallel to the longitudinal axis of the tool, then the x-axis may be radial through the center of the pad, and the y-axis may be tangential to the pad. The zz-component may refer to a z-source and a z-receiver and so on. In some embodiments, xx-transmitters and receivers may be used.

FIG. 2A shows an electromagnetic tool **10** for one embodiment according to the present disclosure. The electromagnetic tool **10** may include a body **55** with two pads **51A**, **51B** extended on extension devices **57A**, **57B**. Two pads are shown for illustrative purposes and, in actual practice, there may be more pads. The extension devices may be electrically operated, electromechanically operated, mechanically operated or hydraulically operated. With the extension devices **57A**, **57B** fully extended, the pads **51A**, **51B** can make contact with the borehole wall (not shown) and make measurements indicative of properties of the borehole wall. Orientation sensors (not shown) may provide an indication of the orientation of the electromagnetic tool **10**. In addition, cable depth measurements may be obtained using a sensor (not shown) at the surface that measures the amount of cable spooled out. In addition, accelerometers may be used downhole to provide other measurements indicative of the depth of the electromagnetic tool **10**. The orientation sensors may include accelerometers, magnetometers or gyroscopes. Depth may also be estimated from a gyro output.

An exemplary arrangement of dual transmitters and receivers on each of the pads is shown in **FIG. 2B**. Shown therein is pad **51A** with two transmitters **55A**, **55B** disposed about two receivers **57A**, **57B**. Also depicted schematically by arrows in **FIG. 2B** are measurements that may be made by each of the two receivers **57A**, **57B** corresponding to signals generated by each of the two transmitters **55A**, **55B**.

The use of dual transmitters may provide a symmetrical response. The use of dual transmitters may also reduce effects of borehole rugosity. Also, the use of dual transmitters may reduce electronics-related errors in attenuation measurement. The electronics-related errors may not affect the phase difference measurement. When in the Mini-MPR mode, the two transmitters **55A**, **55B** may be placed symmetrically with respect to the receiver antennas **57A**, **57B**. Attenuation and phase

difference are measured for each of the transmitters **55A**, **55B**. The measurements may be averaged to give the final readings:

$$\begin{aligned} Att &= \frac{Att_{T1} + Att_{T2}}{2}; \\ Pha &= \frac{Pha_{T1} + Pha_{T2}}{2} \end{aligned} \quad (2)$$

where the subscripts T1 and T2 denote the first and second receivers. Assuming a uniform earth formation for which the magnetic fields at the receiver locations are H_1 and H_2 and assuming that the two receivers have gains G_1 and G_2 , the ratio of the two receiver outputs R_{T1} for the 1st transmitter may be derived from the ratio:

$$R_{T1} = \frac{G_2 H_2}{G_1 H_1} = \frac{G_2}{G_1} \frac{A_2}{A_1} e^{i\Delta\phi} \quad (3)$$

where A_1 and A_2 are the amplitudes of H_1 and H_2 , respectively; $\Delta\phi$ is the phase difference between the two receivers. From eqn. (3) it follows

$$Att_{T1} = -20 \log \frac{G_2}{G_1} - 20 \log \frac{A_2}{A_1}, \quad (4)$$

$$Pha_{T1} = \Delta\phi. \quad (5)$$

Thus, it is clear that the gain change affects attenuation measurement but not the phase difference measurement.

Similarly, attenuation measurement for the 2nd transmitter is derived from

$$R_{T1} = \frac{G_1 H_2}{G_2 H_1} = \frac{G_1}{G_2} \frac{A_2}{A_1} e^{i\Delta\phi}. \quad (6)$$

The attenuation measurement may be written as:

$$Att_{T1} = -20 \log \frac{G_1}{G_2} - 20 \log \frac{A_2}{A_1}. \quad (7)$$

Averaging equations (3) and (4) may remove the effect of gain variation. Those versed in the art would recognize that measurements of amplitude and phase can, in addition to resistivity determination, also be used for determining the dielectric constant of the earth formation.

FIG. 3A shows a schematic of a generic tool configuration for one embodiment according to the present disclosure. Here, multiple receiver pairs of receivers may be used to achieve sufficient azimuthal coverage. Two receiver arrays **103A**, **103B** may be placed on a pad **51A**. For each receiver **105** in the upper array **103A**, there is a

corresponding receiver **105** in the lower array **103B**. In one embodiment, the coils **101A**, **101B** of the upper and lower receiver arrays may be aligned radially with respect to the tool axis (movement) direction. The receiver coils **105** are separated laterally by a constant distance that is determined by the azimuthal resolution of the electromagnetic tool. Two transmitting antennas **101A**, **101B** may be placed above receiver array **103A** and below receiver array **103B**. The transmitting antennas **101A**, **101B** may be operated one at a time during which measurements from each and every receiver pair are made. An exemplary current flow direction for the transmitters **101A**, **101B** is shown by the arrows in **FIG. 3A**. With the indicated current flow of the transmitters **101A**, **101B** and the coil orientation of the receivers **105**, the measurements made would be xx-measurements. The measurements may include attenuation rate, phase difference, or compensated magnetic field.

FIG. 3B shows a schematic of another embodiment of a generic tool configuration with staggered receiver pairs according to the present disclosure. Depending on the size of the receiver coils **101A**, **101B**, the receiver pairs may be staggered in the tool axis direction, allowing a small separation between the receiver pairs. The upper receiver array **103A'** may comprise two staggered rows of receivers and the lower receiver array **103B'** may comprise two staggered rows of receivers **105** to reduce the gaps in azimuthal coverage of the configuration of **FIG. 3A**.

FIG. 4A is a schematic of a transmitter for one embodiment according to the present disclosure. Transmitters **101A'** and **101B'** may have wires wound around the pad **51A**. The wire paths may be substantially normal to the tool axis, going in the front, back, and on sides of the pad **51A**. With the configuration shown in **FIG. 4A**, the measurements would be zx-measurements.

FIG. 4B is a schematic of a transmitter for another embodiment according to the present disclosure. Transmitters **101A''**, **101B''** may be electric dipoles normal to the tool axis.

FIG. 5 is a flow chart of one method **500** for estimating a fluid saturation according to one embodiment of the present disclosure. In step **510**, electromagnetic tool **51A** may be conveyed in the borehole **12**. In step **520**, signals at a plurality of frequencies may be transmitted from transmitters **101A**, **101B** into the earth formation. In some embodiments, at least one of the plurality of frequencies may be at a frequency at or above 500 MHz. In step **530**, receivers **103A**, **103B** may generate an

output indicative the complex dielectric permittivity of the earth formation **13**. In step **540**, a rate of change of the imaginary part of the complex dielectric permittivity relative to the real part of the complex dielectric permittivity may be estimated using the generated output. In step **550**, a fluid saturation may be estimated using the estimated rate of change.

The selection of the plurality of frequencies may include frequencies at or near the high frequency limit of the real part of dielectric permittivity for the particular polarization type of the earth formation. Several basic polarization types depending on colloid structure of oil, water contact with the containing porous medium, and water-oil contact in the containing medium can be identified. The physical bases in these cases correspond to migration polarization (the Maxwell-Wagner polarization) at the contacts between colloid particles in oil, polarization of the double layer and bulk charge at the contacts between water and the rock matrix of the containing porous medium, etc. Each polarization type may be identified with a specific structural unit of the medium and cataloged in the dielectric spectra. Determination of the particle type in the colloid solution in the porous medium may be then reduced to the problem of identification of the cataloged and the measured spectra. It should be noted that all polarization types can be reduced to the following three basic polarization types:

Havriliak-Negami relaxation (its specific cases are the Cole-Davidson, Debye, and Cole-Cole relaxations) characterized by frequency dependence of the complex value of dielectric permittivity

$$\varepsilon^* = \varepsilon_{\infty} + (\varepsilon_s - \varepsilon_{\infty}) \left[1 + (i\omega\tau)^{1-\alpha} \right]^{-\beta} \quad (8)$$

$$\varepsilon^* = \varepsilon' - i\varepsilon'' \quad (9)$$

m-th power law relaxation

$$\varepsilon^* = A \cdot (i\omega)^{-m} \quad (10)$$

Maxwell-Wagner relaxation

$$\varepsilon^* = \varepsilon_{\infty} + 4\pi\sigma / i\omega + (\varepsilon_s - \varepsilon_{\infty}) / (1 + i\omega\tau) \quad (11)$$

FIG. 6 shows a set of complex permittivity curves depicting spectral images of dielectric permittivity for different relaxations related to polarization types and associated with colloidal structure of fluid within a saturated porous medium. The Maxwell-Wagner relaxation determines the phase of colloid particles, the m-th power

law relaxation corresponds to laminated or disk-shaped micellar colloid particles, the Debye relaxation corresponds to crystalline solid colloid particles, the Cole-Davidson relaxation corresponds to local crystalline structuring in colloid particles, etc. Having compiled the catalog of polarization types, the structure of water-oil mixture and colloid oil contents in the saturated porous medium may be identified. The structure of the water-oil mixture may be indicative of permeability of the earth formation. For example, water-saturated sandstones and dolomites may have a polarization type that demonstrates Cole-Cole relaxation. The polarization type may be identified using electromagnetic logging of the borehole.

FIG. 7 shows a chart with a set of curves representing the frequency dependence complex dielectric permittivity of sandstone saturated with (i) water and (ii) a mixture of water and transformer oil. Curve **710** indicates the real part of dielectric permittivity for sandstone saturated with water. Curve **720** indicates the imaginary part of dielectric permittivity for sandstone saturated with water. Curve **730** indicates the real part of dielectric permittivity for sandstone saturated with a mixture of water and transformer oil. Curve **740** indicates the imaginary part of dielectric permittivity for sandstone saturated with a mixture of water and transformer oil.

In the case when both water and oil are present in the earth formation **13**, step **550** may include finding a bulk fraction of water if there is no oil and a bulk fraction of water in the presence of oil. The difference between these two values may yield the bulk fraction of oil. The method of finding water saturation and oil saturation is illustrated below using the cases of the Cole-Cole relaxation and the Havriliak-Negami relaxation. The estimate of the dielectric permittivity may assume a natural porous medium, such as sandstone or dolomite, that is saturated with water and assuming that the dielectric polarization type of this system was established via borehole measurements.

FIG. 8 shows an exemplary set of curves for sandstone expressing complex dielectric permittivity over a range of frequencies. In water-saturated sandstones, the Cole-Cole relaxation is typically observed as shown in as curve **710** and may be expressed as follows.

$$\epsilon^* = \epsilon_{\infty} + \frac{\epsilon_s - \epsilon_{\infty}}{1 + (i\omega\tau)^{1-\alpha}} \quad (12)$$

where ε^* is complex dielectric permittivity, ε_∞ the asymptotic value of the real part of this polarization type at high frequencies, ε_s is the static value of dielectric permittivity, τ is relaxation time, α is a parameter ranging from 0 to 1, which characterizes the polarization angle. It has been established experimentally that natural media like sandstones or dolomites demonstrate that the asymptotic value of the real part of dielectric permittivity depends only on water saturation of the pore space and does not depend on the saline concentration in saturating water and rock type. In other words, ε_∞ is a universal function of water saturation of the porous rock. Frequency dependencies of the real and imaginary parts of dielectric permittivity for water-saturated formations (real part, imaginary part) shown in curve **810** appear to be symmetrical with respect to the maximum of the imaginary part of dielectric permittivity. Curve **820** may represent the Havriliak-Negami relaxation is observed when oil is present. When oil is present, the symmetry in the high frequency domain may no longer remain as shown with curve **820**.

The distortion angles **830**, **840** between each of the spectral dielectric curves **810**, **820** and the x-axis may depend on the bulk fraction of the oil present in the formation. Distortion may be obtained from the spectral dependences of the dielectric constant (the real and imaginary parts) in the low frequency domain. Knowing the distortion angle, the bulk fraction of the oil present in the formation may be determined.

For Cole-Cole relaxation it is known that:

$$\varepsilon''_{\max} = (\varepsilon_s - \varepsilon_\infty) \cdot \tan[(1-\alpha)\pi/4]/2 \quad (13)$$

where ε''_{\max} is the maximal loss factor, ε_s is the static value of the real part of dielectric, ε_∞ is its high-frequency limit, and α is the polarization parameter. It is also known, for Cole-Cole relaxation, that the following relationship is true.

$$\varepsilon_s = 2\varepsilon'_{\max} - \varepsilon_\infty \quad (14)$$

Using eqns. (13) and (14), it follows that:

$$\varepsilon_\infty = \varepsilon'_{\max} - \varepsilon''_{\max} / \tan[(1-\alpha)\pi/4]/2 = \varepsilon_\infty(K) \quad (15)$$

where $\varepsilon_{\infty}(K)$ is a given universal function of water saturation (water fraction in per cent). The universal curve $\varepsilon_{\infty}(K\%)$ may be obtained via laboratory experiments, and ε''_{\max} , ε'_{\max} , α may be obtained via inductive logging.

If both water and oil are present in the porous space, the polarization curve follows the Havriliak-Negami formula as shown as curve **720** in **FIG. 7** and expressed as follows.

$$\varepsilon^* = \varepsilon_{\infty} + \frac{\varepsilon_s - \varepsilon_{\infty}}{[1 + (i\omega\tau)^{1-\alpha}]^{\beta}} \quad (16)$$

where there are two polarization parameters: α and β .

The presence of the β term may result in the high-frequency limit of the real part of complex dielectric permittivity depending in part on oil contents. For small distortions of the left angle in curve **820**, expansion with respect to the power indices $\beta - 1$ may be performed with the accuracy of quadratic terms and has the following form:

$$\varepsilon_{\infty} = \varepsilon_{\infty,0} + \varepsilon_s(\beta - 1)/2 + \dots \quad (17)$$

The first term of this expansion may describe angle distortions correctly up to the values of $\beta = 0.7$. In the case of a further decrease of β , the quadratic terms are to be taken into account. When oil is present in the porous space, water saturation may be calculated for the no-oil case K_{water} using the right hand angle. Polarization parameters ε''_{\max} and ε'_{\max} may be found via the right hand angle. Based on the polarization curve for the oil case, $\beta = 0.7$ may be calculated using the eqn (13).

Using the following dependence:

$$\varepsilon_{\infty,0} + \varepsilon_s(\beta - 1)/2 = \varepsilon_{\infty}(K_{o-w}) \quad (18)$$

the water fraction in the presence of oil K_{o-w} may be calculated. Oil content K_{oil} may then found via the following formula:

$$K_{oil} = K_{water} - K_{o-w} \quad (19)$$

This example using the Cole-Cole relaxation case is illustrative and exemplary only, as other polarization types may be used, including, but not limited to, Debye relaxation, Cole-Davidson relaxation, m-th power law relaxation, and Maxwell-Wagner relaxation.

FIG. 9 shows a chart with a set of curves representing complex dielectric permittivity of an earth formation over a range of frequencies where water and oil are present according to one embodiment of the present disclosure. Curve **910** represents a true Havriliak-Negami relaxation for sandstone. Curves **920, 930, 940** represent the complex dielectric permittivity of the sandstone when probes with 1-meter, 0.5-meter, and 0.25-meter probe lengths are used to estimate permittivity. It may be observed that the shape of the dielectric spectrum may be insensitive to differences in probe length. Hence, the distortion angle **950** may remain the same despite different probe lengths.

As described herein, the method in accordance with the presently disclosed embodiment of the disclosure involves several computational steps. As would be apparent by persons of ordinary skill, these steps may be performed by computational means such as a computer, or may be performed manually by an analyst, or by some combination thereof. As an example, where the disclosed embodiment calls for selection of measured values having certain characteristics, it would be apparent to those of ordinary skill in the art that such comparison could be performed based upon a subjective assessment by an analyst or by computational assessment by a computer system properly programmed to perform such a function. To the extent that the present disclosure is implemented utilizing computer equipment to perform one or more functions, it is believed that programming computer equipment to perform these steps would be a matter of routine engineering to persons of ordinary skill in the art having the benefit of the present disclosure.

Implicit in the processing of the acquired data is the use of a computer program implemented on a suitable computational platform (dedicated or general purpose) and embodied in a suitable machine readable medium that enables the processor to perform the control and processing. The term "processor" as used in the present disclosure is intended to encompass such devices as microcontrollers, microprocessors, field-programmable gate arrays (FPGAs) and the storage medium may include ROM, RAM, EPROM, EAROM, solid-state disk, optical media, magnetic media and other media and/or storage mechanisms as may be deemed appropriate. As discussed above, processing and control functions may be performed downhole, at the surface, or in both locations.

From the foregoing disclosure, it should be apparent that a method and apparatus for evaluating an earth formation has been disclosed involving the measurement of electrical characteristics including formation dielectric permittivity and involving measurements taken at a plurality of measurement frequencies.

5 Although a specific embodiment of the disclosure as well as possible variants and alternatives thereof have been described and/or suggested herein, it is to be understood that the present disclosure is intended to teach, suggest, and illustrate various features and aspects of the disclosure, but is not intended to be limiting with respect to the scope of the disclosure, as defined exclusively in and by the claims,
10 which follow.

 While the foregoing disclosure is directed to the specific embodiments of the disclosure, various modifications will be apparent to those skilled in the art. It is intended that all such variations within the scope of the appended claims be embraced by the foregoing disclosure.

CLAIMS

1. A method of evaluating an earth formation, the method comprising:
estimating a fluid saturation in the earth formation using an estimated rate of change
5 at a high frequency of an imaginary part of a permittivity of the earth formation
relative to a real part of the permittivity of the earth formation, where the imaginary
part and the real part are based on measurements using an electromagnetic tool at a
plurality of frequencies in a borehole penetrating the earth formation.

10 2. The method of claim 1, further comprising: conveying the electromagnetic
tool in the borehole.

15 3. The method of claim 2, further comprising: using the electromagnetic tool for
making the measurements at the plurality of frequencies.

4. The method of claim 3, further comprising: inverting the measurements to
generate the imaginary part and the real part at the plurality of frequencies; and
estimating the rate of change of the imaginary part relative to the real part.

20 5. The method of claim 1, wherein the electromagnetic tool uses electrical
induction.

25 6. The method of claim 1, wherein the high frequency includes frequencies of
500 MHz and higher.

7. The method of claim 1, further comprising: estimating a colloidal property of
the earth formation using the estimated rate of change.

30 8. An apparatus for evaluating an earth formation, the apparatus comprising:
a carrier configured to be conveyed in a borehole penetrating the earth
formation;

- 16 -

a electromagnetic tool disposed on the carrier and configured to make measurements indicative of an imaginary part and a real part of a permittivity of the earth formation at a plurality of frequencies; and at least one processor configured to:

5 estimate the imaginary part and the real part at the plurality of frequencies by inventing the measurements, and estimate a rate of change at a high frequency of the imaginary part relative to the real part.

10 9. The apparatus of claim 8, wherein the electromagnetic tool is configured to use electric induction.

10. The apparatus of claim 8, wherein the high frequency includes frequencies of 500 MHz and higher.

15

11. The apparatus of claim 8, wherein the at least one processor is further configured estimate a colloidal property of the earth formation using the estimated rate of change.

20 12. A computer-readable medium product having instructions thereon that, when executed, cause at least one processor to perform a method, the method comprising: estimating a fluid saturation in an earth formation using an estimated rate of change at a high frequency of an imaginary part of a permittivity of the earth formation relative to a real part of the permittivity of the earth formation, where the imaginary part and
25 the real part are based on measurements using an electromagnetic tool at a plurality of frequencies in a borehole penetrating the earth formation.

30 13. The non-transitory computer-readable medium product of claim 12 further comprising at least one of: (i) a ROM, (ii) an EPROM, (iii) an EEPROM, (iv) a flash memory, or (v) an optical disk.

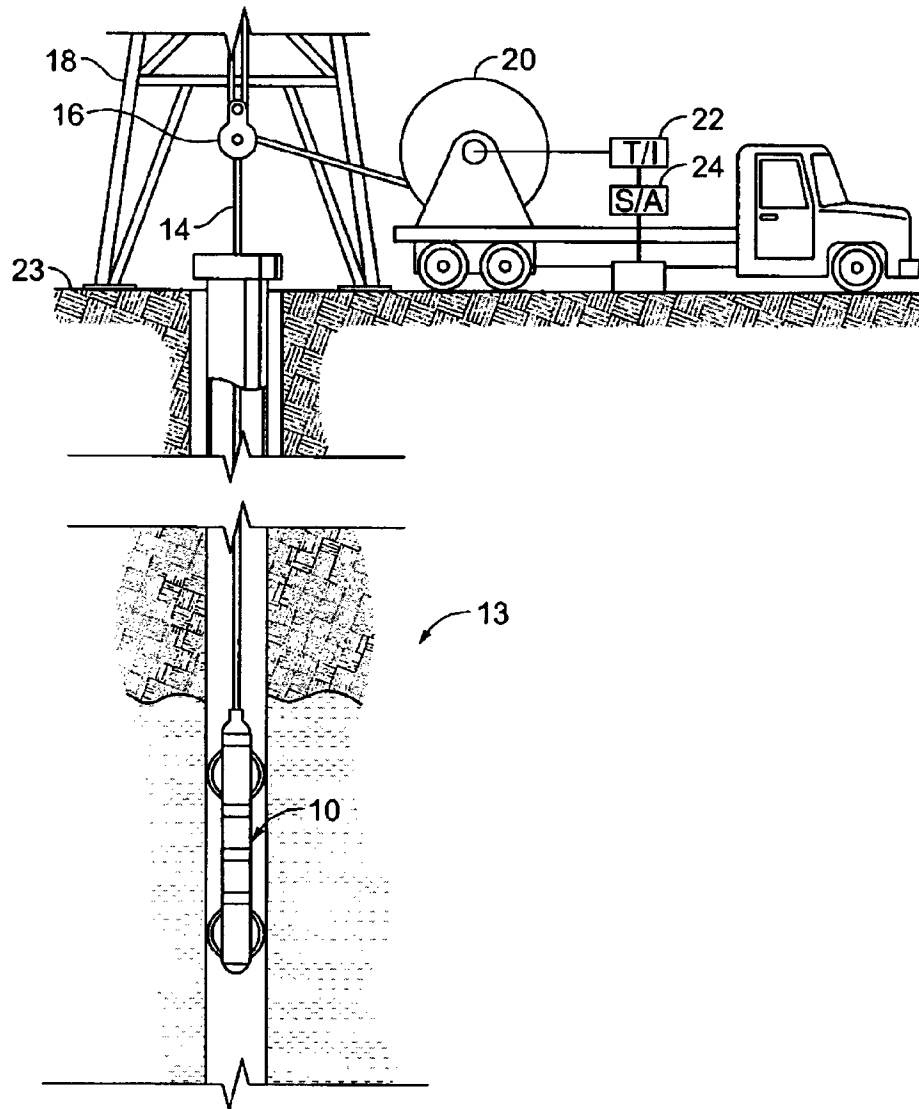

FIG. 1

2/9

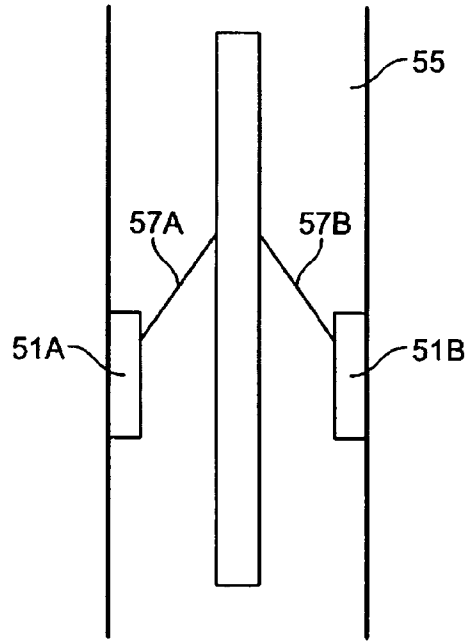

FIG. 2A

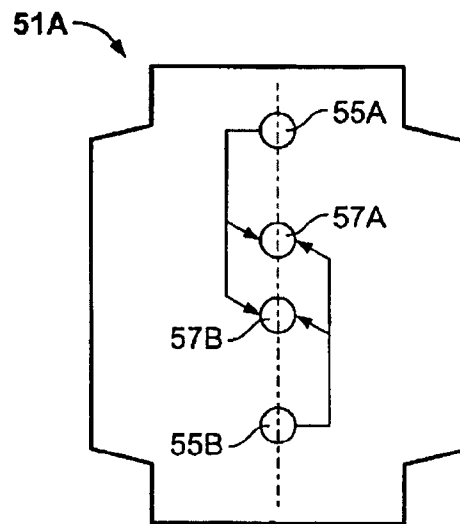

FIG. 2B

3/9

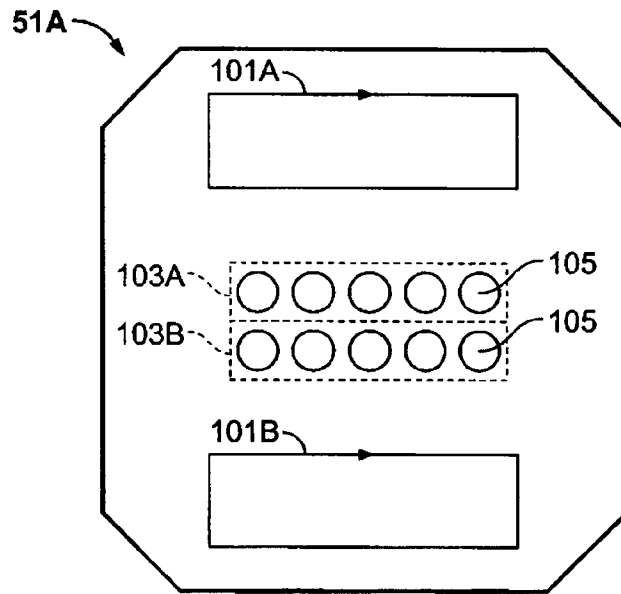

FIG. 3A

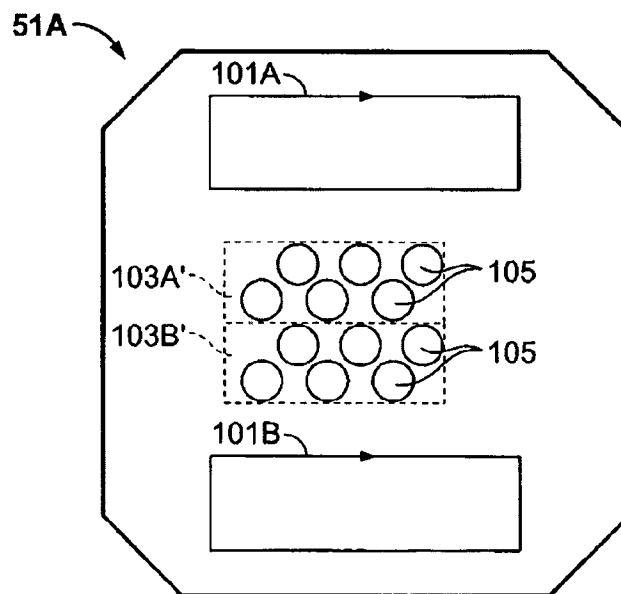

FIG. 3B

4/9

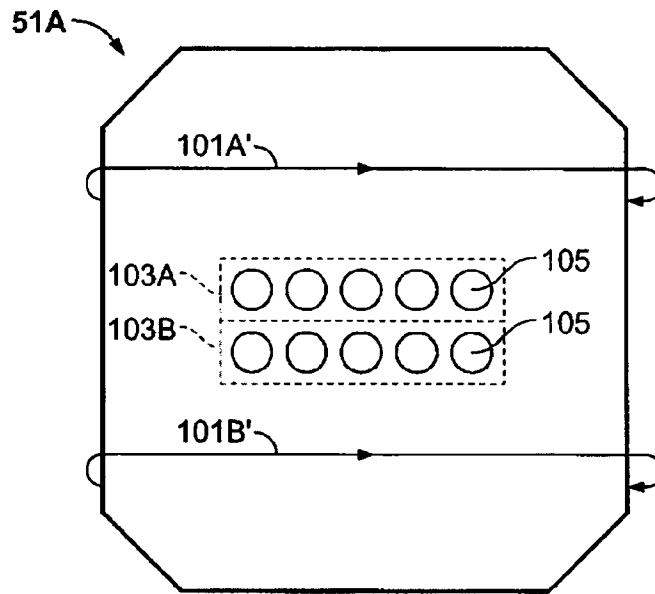

FIG. 4A

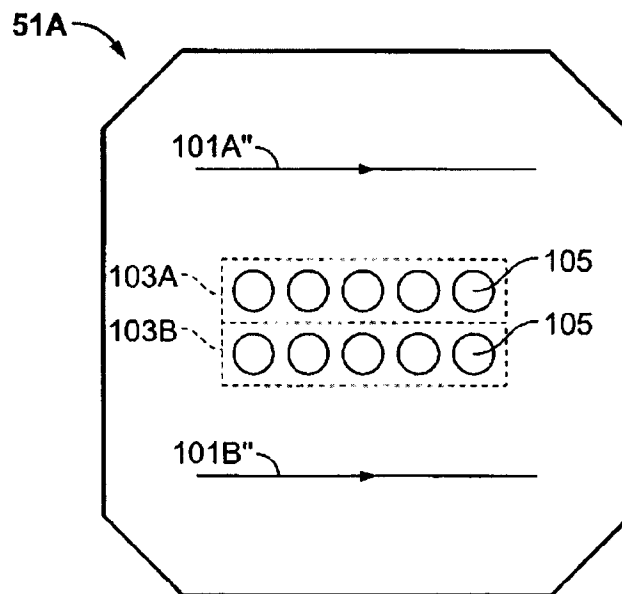

FIG. 4B

5/9

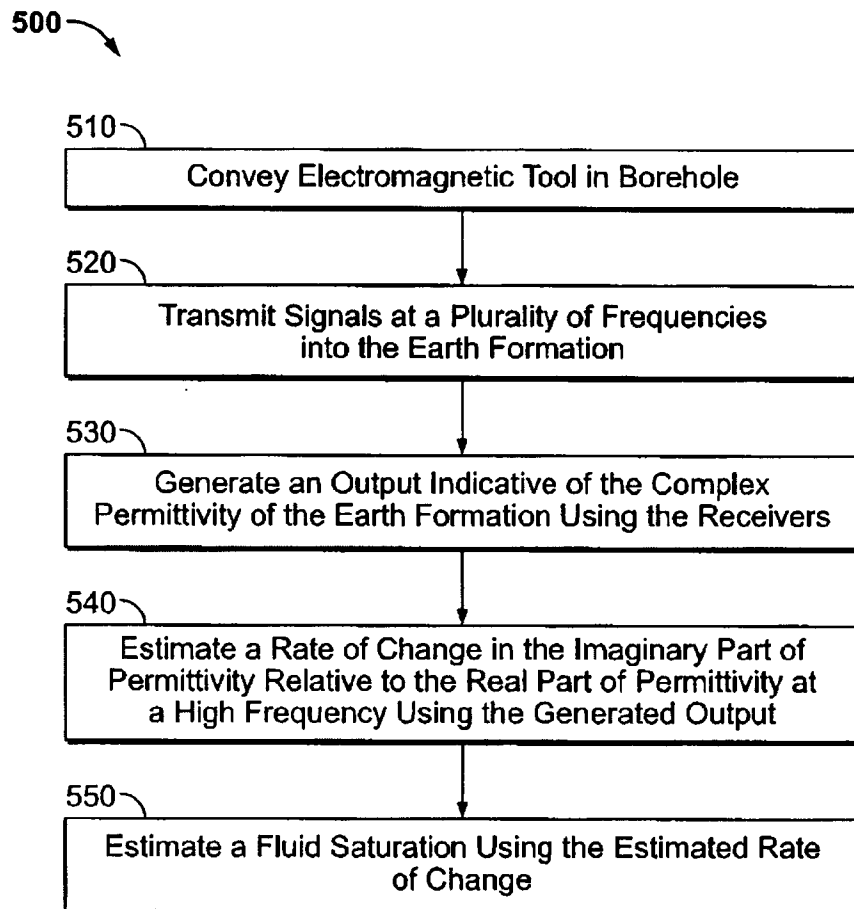

FIG. 5

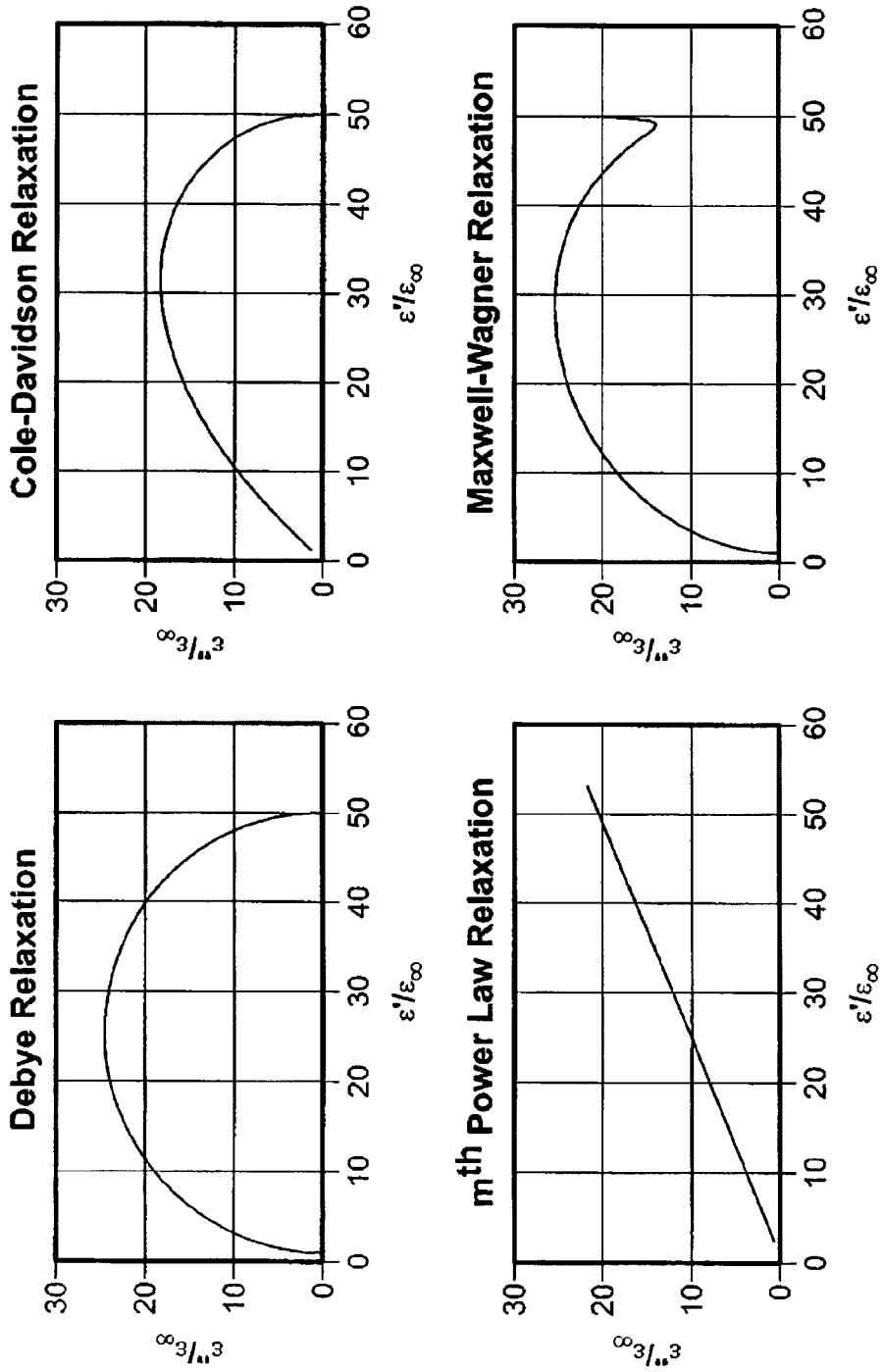

FIG. 6

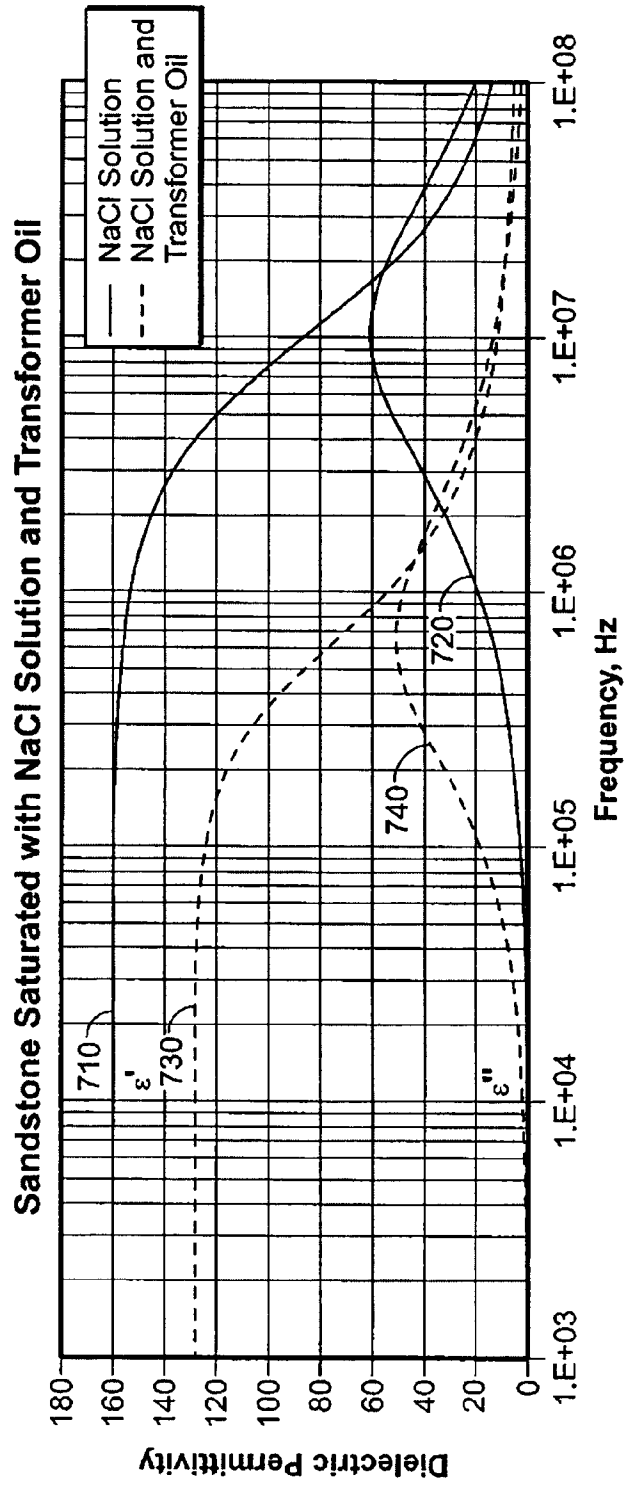

FIG. 7

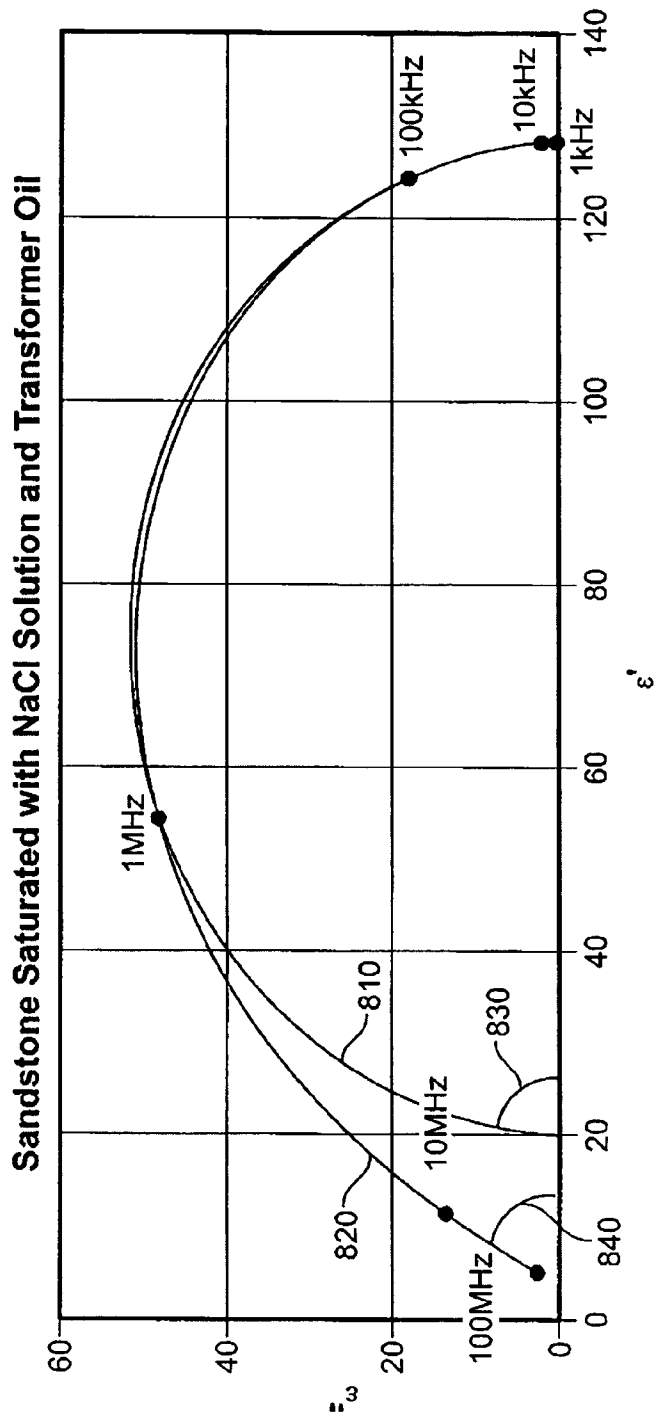

FIG. 8

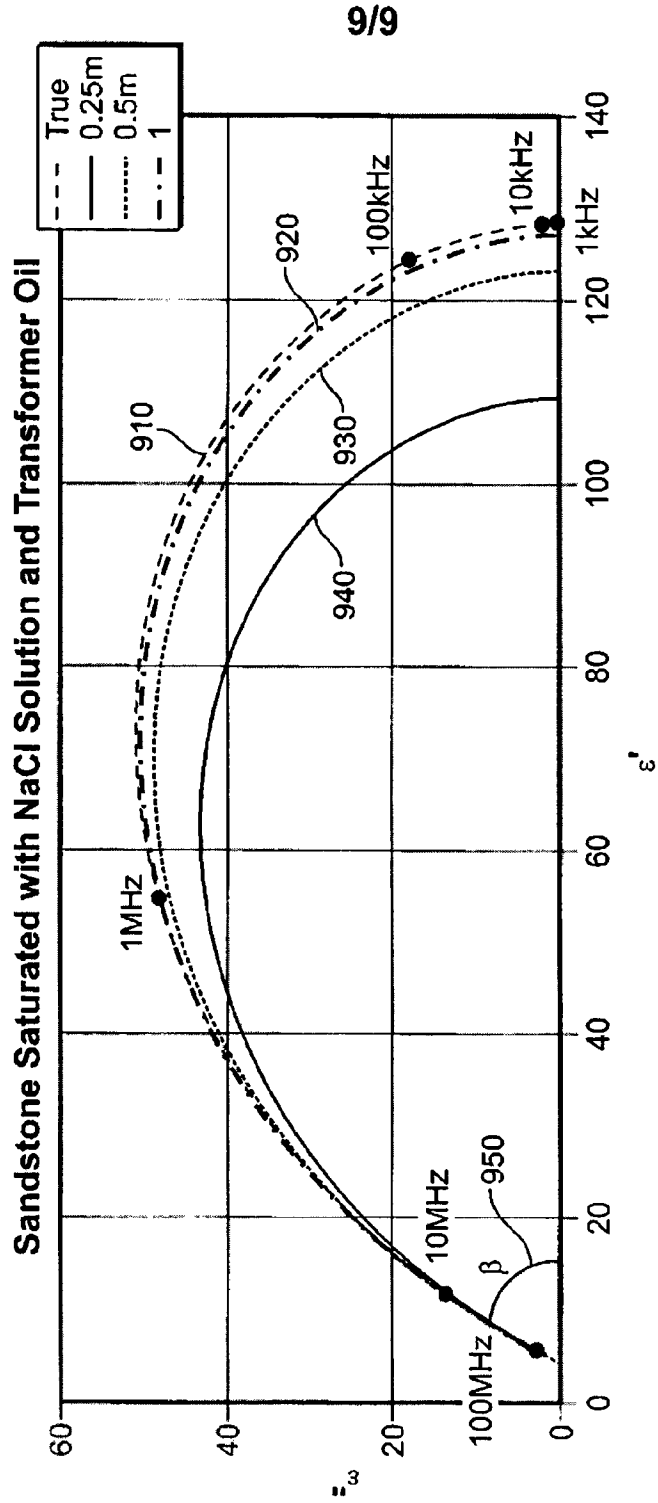

FIG. 9

INTERNATIONAL SEARCH REPORT

International application No
PCT/RU2011/000528

A. CLASSIFICATION OF SUBJECT MATTER
 INV. G01V3/30 G01V3/38
 ADD.

According to International Patent Classification (IPC) or to both national classification and IPC

B. FIELDS SEARCHED
 Minimum documentation searched (classification system followed by classification symbols)
 G01V

Documentation searched other than minimum documentation to the extent that such documents are included in the fields searched

Electronic data base consulted during the international search (name of data base and, where practicable, search terms used)
 EPO-Internal, WPI Data

C. DOCUMENTS CONSIDERED TO BE RELEVANT

Category*	Citation of document, with indication, where appropriate, of the relevant passages	Relevant to claim No.
X	US 5 059 907 A (SHERMAN MICHAEL M [US]) 22 October 1991 (1991-10-22) abstract figures 4,5 column 2, line 57 - column 4, line 49 -----	1-13
X	US 6 831 470 B2 (XIE GHENG-GANG [GB] ET AL XIE CHENG-GANG [GB] ET AL) 14 December 2004 (2004-12-14) figures 5-10,12 column 5, lines 22-25 column 8, lines 48-53 column 15, lines 44-61 ----- -/--	1-13

Further documents are listed in the continuation of Box C. See patent family annex.

* Special categories of cited documents :

"A" document defining the general state of the art which is not considered to be of particular relevance	"T" later document published after the international filing date or priority date and not in conflict with the application but cited to understand the principle or theory underlying the invention
"E" earlier application or patent but published on or after the international filing date	"X" document of particular relevance; the claimed invention cannot be considered novel or cannot be considered to involve an inventive step when the document is taken alone
"L" document which may throw doubts on priority claim(s) or which is cited to establish the publication date of another citation or other special reason (as specified)	"Y" document of particular relevance; the claimed invention cannot be considered to involve an inventive step when the document is combined with one or more other such documents, such combination being obvious to a person skilled in the art
"O" document referring to an oral disclosure, use, exhibition or other means	"&" document member of the same patent family
"P" document published prior to the international filing date but later than the priority date claimed	

Date of the actual completion of the international search 19 June 2012	Date of mailing of the international search report 28/06/2012
---	--

Name and mailing address of the ISA/ European Patent Office, P.B. 5818 Patentlaan 2 NL - 2280 HV Rijswijk Tel. (+31-70) 340-2040, Fax: (+31-70) 340-3016	Authorized officer Meyer, Matthias
--	---

INTERNATIONAL SEARCH REPORT

International application No

PCT/RU2011/000528

C(Continuation). DOCUMENTS CONSIDERED TO BE RELEVANT

Category*	Citation of document, with indication, where appropriate, of the relevant passages	Relevant to claim No.
X	US 2007/061083 A1 (HABASHY TAREK [US] ET AL) 15 March 2007 (2007-03-15) abstract paragraph [0015] paragraphs [0030] - [0042] claim 4 -----	1,8,12
X	EP 2 237 075 A1 (SCHLUMBERGER SERVICES PETROL [FR]; SCHLUMBERGER TECHNOLOGY BV [NL]; SC) 6 October 2010 (2010-10-06) abstract paragraphs [0002] - [0004] paragraphs [0020] - [0022] paragraph [0027] -----	1,8,12
X	US 5 869 968 A (BROOKS ANDREW G [US] ET AL) 9 February 1999 (1999-02-09) figures 20,22-24 paragraph [0123] -----	1,8,12
X	US 2009/200016 A1 (GOODWIN ANTHONY R H [US] ET AL) 13 August 2009 (2009-08-13) figures 3,4,6,7 -----	1,8,12
A	US 7 508 221 B2 (WUERSCH CHRISTOPH [CH] ET AL) 24 March 2009 (2009-03-24) figure 3 -----	1-13
X	OSWALD B ET AL: "A NEW COMPUTATIONAL TECHNIQUE FOR PROCESSING TRANSMISSION-LINE MEASUREMENTS TO DETERMINE DISPERSIVE DIELECTRIC PROPERTIES", GEOPHYSICS, SOCIETY OF EXPLORATION GEOPHYSICISTS, US, vol. 71, no. 2, 1 March 2006 (2006-03-01), pages K31-K35, XP001241083, ISSN: 0016-8033, DOI: 10.1190/1.2187764 the whole document -----	1,8,12

INTERNATIONAL SEARCH REPORT

Information on patent family members

International application No PCT/RU2011/000528

Patent document cited in search report	Publication date	Patent family member(s)	Publication date
US 5059907	A	22-10-1991	NONE

US 6831470	B2	14-12-2004	GB 2376074 A 04-12-2002 NO 20022553 A 02-12-2002 US 2003011386 A1 16-01-2003

US 2007061083	A1	15-03-2007	CA 2558909 A1 12-03-2007 CA 2559119 A1 12-03-2007 GB 2430264 A 21-03-2007 GB 2430265 A 21-03-2007 US 2007061082 A1 15-03-2007 US 2007061083 A1 15-03-2007

EP 2237075	A1	06-10-2010	NONE

US 5869968	A	09-02-1999	NONE

US 2009200016	A1	13-08-2009	CA 2714501 A1 13-08-2009 US 2009200016 A1 13-08-2009 WO 2009099930 A1 13-08-2009

US 7508221	B2	24-03-2009	DE 102005037632 A1 15-02-2007 EP 1760493 A2 07-03-2007 JP 2007047165 A 22-02-2007 US 2007035313 A1 15-02-2007
