

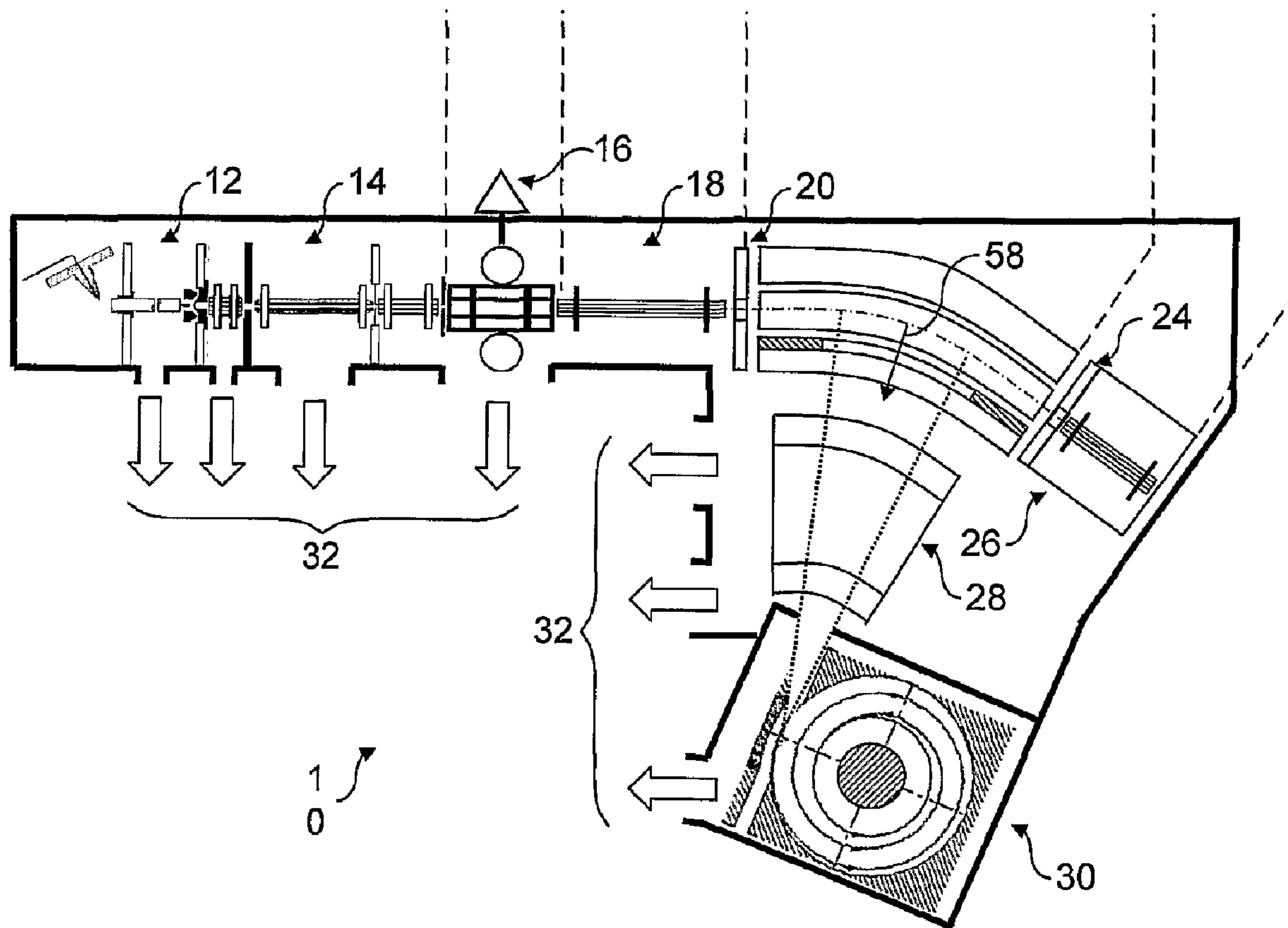

(86) Date de dépôt PCT/PCT Filing Date: 2006/03/29
 (87) Date publication PCT/PCT Publication Date: 2006/10/05
 (45) Date de délivrance/Issue Date: 2012/08/07
 (85) Entrée phase nationale/National Entry: 2007/09/17
 (86) N° demande PCT/PCT Application No.: GB 2006/001170
 (87) N° publication PCT/PCT Publication No.: 2006/103445
 (30) Priorité/Priority: 2005/03/29 (GB0506287.2)

(51) Cl.Int./Int.Cl. *H01J 49/00* (2006.01),
B01D 59/44 (2006.01), *H01J 49/02* (2006.01),
H01J 49/04 (2006.01)
 (72) Inventeurs/Inventors:
 MAKAROV, ALEXANDER ALEKSEEVICH, GB;
 DENISOV, EDUARD V., DE;
 JUNG, GERHARD, DE;
 MALEK, ROBERT, DE;
 LANGE, OLIVER, DE
 (73) Propriétaire/Owner:
 THERMO FINNIGAN LLC, US
 (74) Agent: FETHERSTONHAUGH & CO.

(54) Titre : AMELIORATIONS APPORTEES AU PIEGEAGE D'IONS
 (54) Title: IMPROVEMENTS RELATING TO ION TRAPPING



(57) Abrégé/Abstract:

This invention relates to a method of trapping ions and to an ion trapping assembly. In particular, the present invention has application in gas-assisted trapping of ions in an ion trap prior to a mass analysis of the ions in a mass spectrometer. The invention



(57) **Abrégé(suite)/Abstract(continued):**

provides a method of trapping ions in a target ion trap of an ion trapping assembly that comprises a series of volumes arranged such that ions can traverse from one volume to the next, the volumes including the target ion trap, whereby ions are allowed to pass repeatedly through the volumes such that they also pass into and out from the target ion trap without being trapped. Potentials may be used to reflect the ions from respective ends of the ion trapping assembly. Optionally, a potential well and/or gas-assisted cooling may be used to cause the ions to settle in the target ion trap.

(12) INTERNATIONAL APPLICATION PUBLISHED UNDER THE PATENT COOPERATION TREATY (PCT)

(19) World Intellectual Property Organization
International Bureau(43) International Publication Date
5 October 2006 (05.10.2006)

PCT

(10) International Publication Number
WO 2006/103445 A3

(51) International Patent Classification:

H01J 49/00 (2006.01) *H01J 49/04* (2006.01)
H01J 49/02 (2006.01) *B01D 59/44* (2006.01)

(21) International Application Number:

PCT/GB2006/001170

(22) International Filing Date: 29 March 2006 (29.03.2006)

(25) Filing Language: English

(26) Publication Language: English

(30) Priority Data:

0506287.2 29 March 2005 (29.03.2005) GB

(71) Applicant (for all designated States except US):

THERMO FINNIGAN LLC [US/US]; 355 River Oaks Parkway, San Jose, California 95134-1991 (US).

(72) Inventors; and

(75) Inventors/Applicants (for US only): **MAKAROV, Alexander, Alekseevich** [RU/GB]; 90 Marlborough Avenue, Cheadle Hulme, Cheshire. SK8 7AR (GB). **DENISOV, Eduard** [RU/DE]; Buergermeister-spitta-allee 56b, 28329 Bremen (DE). **JUNG, Gerhard** [DE/DE]; Katharinenweg 30a, 27751 Delmenhorst (DE). **MALEK, Robert** [DE/DE]; J.C. Findorff-Str. 42a, 28865 Lilienthal (DE). **LANGE, Oliver** [DE/DE]; Lilienthaler Heerstrasse 94, 28357 Bremen (DE).

(74) Agents: **FROST, Alex, John et al.**; BOULT WADE TENNANT, Verulam Gardens, 70 Gray's Inn Road, London WC1X 8BT (GB).

(81) Designated States (unless otherwise indicated, for every kind of national protection available): AE, AG, AL, AM, AT, AU, AZ, BA, BB, BG, BR, BW, BY, BZ, CA, CH, CN, CO, CR, CU, CZ, DE, DK, DM, DZ, EC, EE, EG, ES, FI, GB, GD, GE, GH, GM, HR, HU, ID, IL, IN, IS, JP, KE, KG, KM, KN, KP, KR, KZ, LC, LK, LR, LS, LT, LU, LV, LY, MA, MD, MG, MK, MN, MW, MX, MZ, NA, NG, NI, NO, NZ, OM, PG, PH, PL, PT, RO, RU, SC, SD, SE, SG, SK, SL, SM, SY, TJ, TM, TN, TR, TT, TZ, UA, UG, US, UZ, VC, VN, YU, ZA, ZM, ZW.

(84) Designated States (unless otherwise indicated, for every kind of regional protection available): ARIPO (BW, GH, GM, KE, LS, MW, MZ, NA, SD, SL, SZ, TZ, UG, ZM, ZW), Eurasian (AM, AZ, BY, KG, KZ, MD, RU, TJ, TM), European (AT, BE, BG, CH, CY, CZ, DE, DK, EE, ES, FI, FR, GB, GR, HU, IE, IS, IT, LT, LU, LV, MC, NL, PL, PT, RO, SE, SI, SK, TR), OAPI (BF, BJ, CF, CG, CI, CM, GA, GN, GQ, GW, ML, MR, NE, SN, TD, TG).

Declaration under Rule 4.17:

— of inventorship (Rule 4.17(iv))

[Continued on next page]

(54) Title: METHOD AND APPARATUS OF ION TRAPPING

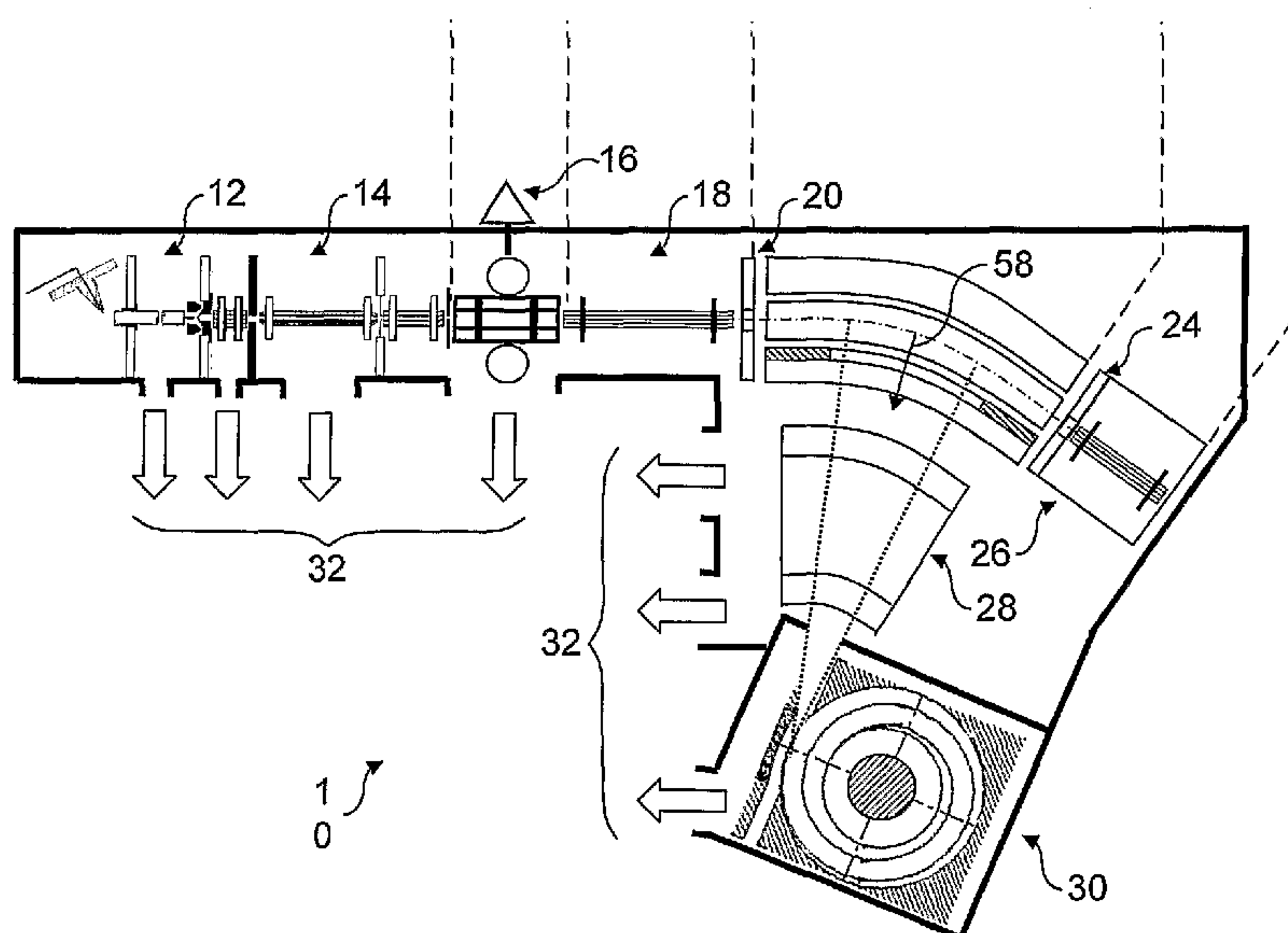

(57) Abstract: This invention relates to a method of trapping ions and to an ion trapping assembly. In particular, the present invention has application in gas-assisted trapping of ions in an ion trap prior to a mass analysis of the ions in a mass spectrometer. The invention provides a method of trapping ions in a target ion trap of an ion trapping assembly that comprises a series of volumes arranged such that ions can traverse from one volume to the next, the volumes including the target ion trap, whereby ions are allowed to pass repeatedly through the volumes such that they also pass into and out from the target ion trap without being trapped. Potentials may be used to reflect the ions from respective ends of the ion trapping assembly. Optionally, a potential well and/or gas-assisted cooling may be used to cause the ions to settle in the target ion trap.

WO 2006/103445 A3

WO 2006/103445 A3



Published:

- *with international search report*
- *before the expiration of the time limit for amending the claims and to be republished in the event of receipt of amendments*

For two-letter codes and other abbreviations, refer to the "Guidance Notes on Codes and Abbreviations" appearing at the beginning of each regular issue of the PCT Gazette.

(88) Date of publication of the international search report:

16 August 2007

- 1 -

IMPROVEMENTS RELATING TO ION TRAPPING

This invention relates to a method of trapping ions and to an ion trapping assembly. In particular, the present invention has application in gas-assisted trapping of ions in an ion trap prior to a mass analysis of the ions in a mass spectrometer.

Such ion traps may be used in order to provide a buffer for an incoming stream of ions and to prepare a packet with spatial, angular and temporal characteristics adequate for the specific mass analyser. Examples of mass analysers include single- or multiple-reflection time-of-flight (TOF), Fourier transform ion cyclotron resonance (FT ICR), electrostatic traps (e.g. of the Orbitrap type), or a further ion trap.

A block diagram of a typical mass spectrometer with an ion trap is shown in Figure 1. The mass spectrometer comprises an ion source that generates and supplies ions to be analysed to a single ion trap where the ions are collected until a desired quantity are available for subsequent analysis. A first detector may be located adjacent to the ion trap so that mass spectra may be taken, under the direction of the controller. The mass spectrometer as a whole is also operated under the direction of the controller. The mass spectrometer is generally located within a vacuum chamber provided with one or more pumps to evacuate its interior.

Ion storage devices that use RF fields for transporting or storing ions have become standard in mass spectrometers, such as the one shown in Figure 1. Figure 2a shows a typical arrangement of four electrodes in a linear ion trap device that traps ions using a combination of DC, RF and AC

- 2 -

fields. The elongate electrodes extend along a z axis, the electrodes being paired in the x and y axes. As can be seen from Figure 2a, each of the four elongate electrodes is split into three along the z axis.

5 Figures 2b and 2c show typical potentials applied to the electrodes. Trapping within the storage device is achieved using a combination of DC and RF fields. The electrodes are shaped to approximate hyperbolic equipotentials and they create a quadrupolar RF field that
10 assists in containing ions entering or created in the trapping device. Figure 2c shows that like RF potentials are applied to opposed electrodes such that the x axis electrodes have a potential of opposite polarity to that of the y axis electrodes. This trapping is assisted by
15 applying elevated DC potentials to the short end sections of each split electrode relative to the longer centre section. This superimposes a potential well on the RF field.

AC potentials may also be applied to the electrodes to create an AC field component that assists in ion selection.

20 Once trapped, ions may be later ejected to a mass analyser either axially from an end of the ion trap or orthogonally through an aperture provided centrally in one of the electrodes.

This type of ion trap is described in further detail in
25 US 5,420,425.

The ion trap may be filled with a gas such that trapping of ions is assisted by the ions losing their initial kinetic energy in low-energy collisions with the gas. After losing sufficient energy, ions are trapped
30 within the potential well formed within the ion trap. Those ions not trapped during the first pass are normally lost to the adjacent ion optics.

- 3 -

For most ions, over a wide range of masses and structures, substantial loss of kinetic energy occurs when the product of gas pressure and distance travelled by the ions ($P \times D$) exceeds around 0.2 to 0.5 mm Torr. Most practical 3D and linear ion traps operate at pressures of around 1 mTorr or lower. This places a requirement for an ion trap of 100 to 150 mm length to provide a sufficiently long path length to avoid excessive ion loss. However, such long ion traps are undesirable because, for example, they result in excessively stringent manufacturing requirements. So practical ion traps have to compromise between the efficiency of ion capture and the length of the system.

Against the background, and from a first aspect, the present invention resides in a method of trapping ions in a target ion trap comprising: introducing ions into an ion trapping assembly comprising a series of volumes arranged such that ions can traverse from one volume to the next, the volumes including the target ion trap; allowing the ions to pass into, through and out from the target ion trap without being trapped; and guiding the ions such that they pass into the target ion trap for a second time.

This invention makes use of the realisation that under certain ion-optical conditions, this compromise could be avoided by providing multiple passes of ions through the series of volumes, wherein ion losses are low on each pass. Trapping within one of the volumes occurs only at the last stages when ion kinetic energy becomes so low that the ions cannot leave that volume anymore. If multiple volumes are used, the volume where ions need to be finally stored could be called the "target ion trap".

The volumes are intended to correspond to discrete parts, e.g. to an ion trap, ion reflectors, ion optics (that

- 4 -

merely serve to guide ions as they pass therethrough), etc. Some parts may be composite and comprise more than a single volume. For example, the target ion trap may comprise a single volume or may comprise a pair of trapping volumes
5 separated by an electrode. A voltage on the electrode could be switched on and off to create a single trapping volume or a pair of trapping volumes. The ion trapping assembly may be part of a larger collection of ion handling parts, e.g. it may be a component of an apparatus comprising an ion
10 source, further ion traps or stores, ion optics, etc.

Providing an ion trapping assembly comprising a target ion trap and other volumes means that the ions may lose energy while traversing a path that is longer than the length of just the target ion trap. This yields a $P \times D$
15 (where D is the length of the target ion trap) much less than 0.2-0.5 mm Torr. Ensuring the ions return to the target ion trap means that the ions can be collected therein.

Conveniently, the method may comprise reflecting the
20 ions such that they pass into the target ion trap for the second time and, optionally, reflecting the ions a second time such that the ions pass into the target ion trap for a third time. This may be achieved by placing a first potential at one end of the ion trapping assembly and
25 placing a second potential at the other end of the ion trapping assembly, thereby causing the ions to reflect at either end and so to traverse the target ion trap repeatedly. In this way the ions repeatedly traverse the ion trapping assembly, providing a far greater path length
30 over which they may lose energy. This is especially useful for heavier peptides and proteins which normally require

longer stopping paths (in extreme cases, up to tens of reflections).

Optionally, RF potentials may be applied to the ends of ion trapping assembly, causing ions to be trapped by a so-called "pseudo-potential" or "effective potential". This pseudo-potential exhibits a high mass dependence, and may be used to trap ions of both positive and negative polarity simultaneously.

In order to ensure that the ions are trapped within the target ion trap, it is preferred to apply potentials to the ion trapping assembly such that, for positive ions, the target ion trap is at the lowest potential among all gas-filled volumes, thereby forming a potential well. In this way, ions will tend to settle in the target ion trap as they lose energy. On the other hand, volumes within the ion trapping assembly with negligible number of collisions per pass (i.e. volumes sustained at considerably better vacuum) do not have such restrictions: their potentials could be lower or higher than that of the target trap.

Optionally, the target ion trap comprises first and second volumes of the series of volumes, the method comprising applying potentials to the ion trapping assembly such that the potential rises at either end of the target ion trap thereby forming a potential well, and such that potential barriers are formed at either end of the ion trapping assembly; introducing ions into the ion trapping assembly where they are subsequently reflected by the potential barriers at either end of the ion trapping assembly, thereby traversing the target ion trap repeatedly while they lose energy eventually to settle in the target ion trap; and subsequently to apply a potential to act between the first and second volumes thereby to split the

- 6 -

ions that have settled in the target ion trap into two groups, one being trapped in the first volume and the other being trapped in the second volume.

Such a method provides a convenient way of trapping two
5 or more ion bunches. The ion bunches may then be treated separately (e.g. sent to different mass spectrometers) or may be treated in the same fashion (e.g. sent to the same detector as a pair of subsequent packets). This method may provide improved cross-calibration of detectors and better
10 quantitative analysis.

The first and second volumes may be adjacent one another. For example, the target ion trap may comprise two volumes separated by a trapping potential placed therebetween. An electrode that extends around the
15 perimeter of the ion trap may be used to provide this potential. Alternatively, the first and second volumes may be separated by a further volume or volumes, such as an ion guide. In this sense, the target ion trap is composite and comprises two separate ion traps. When the ion bunch is to
20 be split, the potential of the dividing volume may be raised relative to the first and second volumes, thereby creating potential wells in the first and second volumes.

From a second aspect, the present invention resided in a method of trapping ions in a target ion trap of an ion
25 trapping assembly comprising a series of volumes arranged such that ions can traverse from one volume to the next, the volumes including the target ion trap, the method comprising: applying potentials to the ion trapping assembly such that (i) the potential rises at either end of the
30 target ion trap, thereby forming a potential well in the target ion trap, (ii) the one or more volumes adjacent the target ion trap are at a higher potential than the target

- 7 -

ion trap, and (iii) potential barriers are formed at either end of the ion trapping assembly; and introducing ions into the ion trapping assembly where they are subsequently reflected by the potential barriers at either end of the ion trapping assembly, thereby traversing the target ion trap repeatedly to settle in the potential well as their energy decreases.

Optionally, the method may further comprise introducing a gas into at least one of the volumes thereby causing gas-assisted trapping of the ions. This represents a preferred method of assisting energy loss of the ions such that they settle in the potential well formed in the target ion trap. A pressure range of 0.1 mTorr to 10 mTorr is preferred, 0.5 mTorr to 2 mTorr being preferred still further.

Optionally, the method may further comprise introducing a gas into a volume adjacent the target ion trap. Preferably, the gas or gases are introduced into the target ion trap and the adjacent volume in such a way that the pressure in the target ion trap is lower than in the adjacent volume.

According to one contemplated embodiment, the method may further comprise trapping ions in an ion store before releasing ions from the ion store into the ion trapping assembly. Optionally, the method may comprise repeatedly trapping ions in the ion store and releasing them into the ion trapping assembly thereby to increase successively the number of ions that finally settle in the target ion trap.

Optionally, the ion trapping assembly has a longitudinal axis corresponding broadly to the ions' motion backwards and forwards through the series of volumes and the method further comprising ejecting ions trapped in the target ion trap substantially orthogonally from the ion

- 8 -

trap. The ions may be ejected, for example, into the entrance of a mass analyser such as an electrostatic (Orbitrap) type analyser or single- or multi-reflection time-of-flight mass analyser. A curved target ion trap may
5 be used to assist in focussing ions ejected orthogonally therefrom.

From a third aspect, the present invention resides in an ion trapping assembly comprising: a series of volumes arranged such that ions can traverse from one volume to the
10 next, the volumes including a target ion trap; electrodes arranged to carry potentials; and a controller arranged to set potentials on the electrodes such that (i) the potential rises at either end of the target ion trap, thereby forming a potential well in the target ion trap, (ii) the one or
15 more volumes adjacent the target ion trap are at a higher potential than the target ion trap, and (iii) potential barriers are formed at either end of the ion trapping assembly.

Optionally, the ion trapping assembly may comprise ion
20 optics corresponding to one of the volumes located adjacent the target ion trap or may comprise an ion reflector corresponding to one of the volumes located adjacent to the target ion trap.

The present invention also extends to an ion source and
25 trapping assembly, comprising an ion source, an optional ion store positioned downstream of the ion source, and an ion trapping assembly as described above positioned downstream. The controller may be arranged to set potentials on the ion store to trap ions produced by the ion source and then to
30 release trapped ions into the ion trapping assembly. As ion sources (e.g. electrospray) frequently contain regions of higher pressure (e.g. atmosphere-to-vacuum interface with

20086-2323

- 9 -

differential pumping and voltages forcing ions through it), these regions could in fact be a part of the ion trapping assembly such that they form one or more of the volumes through which the ions are multiple-reflected before settling in the target ion trap.

5 The present invention also extends to a mass spectrometer comprising an ion trapping assembly or ion source and trapping assembly as described above.

 According to another aspect of the present invention, there is provided a method of trapping ions in a target ion trap comprising: introducing ions into an ion trapping assembly comprising a series of volumes arranged such that ions can
10 traverse from one volume to the next, the volumes including the target ion trap; allowing the ions to pass into, through and out from the target ion trap without being trapped, and into a volume adjacent the target ion trap without being trapped, the target ion trap and the adjacent volume being separated by an electrode defining an aperture; and guiding the ions such that they pass into the target ion trap for a
15 second time.

 According to yet another aspect of the present invention, there is provided a method of gas-assisted trapping of ions in a target ion trap of an ion trapping assembly comprising a series of volumes arranged such that ions can
20 traverse from one volume to the next, the volumes including the target ion trap and a volume adjacent the target ion trap, separated by an electrode defining an aperture, the method comprising: filling at least the volume corresponding to the target ion trap with gas; applying potentials to the ion trapping assembly such that (i) the potential rises at either end of the target ion trap, thereby forming a potential well in the target ion trap, (ii) any of the one or more gas-filled volumes adjacent the target ion trap are
25 at a higher potential than the target ion trap, and (iii) potential barriers are formed at either end of the ion trapping assembly; and introducing ions into the ion trapping assembly where they are subsequently reflected by the potential barriers at either

20086-2323

- 9a -

end of the ion trapping assembly, thereby traversing the target ion trap repeatedly to settle in the potential well as their energy decreases without being trapped in the volume adjacent the target ion trap.

According to still another aspect of the present invention, there is
5 provided an ion trapping assembly comprising: a series of volumes arranged such that ions can traverse from one volume to the next, wherein some of the volumes are adapted to be filled with gas, and wherein the series of volumes include a target ion trap and a volume adjacent the target in trap, separated by an electrode defining an aperture; electrodes arranged to carry potentials; and a controller arranged to set
10 potentials on the electrodes such that, at the same time, (i) the potential rises at either end of the target ion trap, thereby forming a potential well in the target ion trap, (ii) the one or more volumes adapted to be filled with gas adjacent the target ion trap are at a higher potential than the target ion trap, and (iii) potential barriers are formed at either end of the ion trapping assembly.

15 According to yet another aspect of the present invention, there is provided an ion source and trapping assembly, comprising an ion source, an ion store positioned downstream of the ion source, and the ion trapping assembly as described herein positioned downstream of the ion store.

20 According to a further aspect of the present invention, there is provided a mass spectrometer comprising the ion trapping assembly as described herein.

According to yet a further aspect of the present invention, there is provided a mass spectrometer comprising the ion source and trapping assembly as described herein.

25 In order that the invention may be more readily understood, reference will now be made, by way of example only, to the following drawings, in which:

20086-2323

- 9b -

Figure 1 is a block diagram representation of a mass spectrometer;

Figure 2a is a representation of a linear quadrupole ion trap and Figures 2b and 2c illustrate the DC, AC and RF potentials used for operation of the ion trap;

5 Figure 3a shows an Orbitrap-type mass spectrometer including an ion trapping assembly according to an embodiment of the present invention, and Figure 3b shows the potentials placed on the ion trapping assembly in use; and

Figures 4a to 4e show schematically five embodiments of ion trapping assemblies according to the present invention.

10 A mass spectrometer 10 of the Orbitrap type is shown in Figure 3a, although not to scale. The mass spectrometer 10 is generally linear in arrangement, with ions passing along the longitudinal (z) axis. The front end of the spectrometer 10 comprises an ion source 12. The ion source 12 may be chosen from the variety of well-known types as desired, for example electrospray,
15 MALDI or any other known type. Ion optics 14 are located adjacent the ion source 12, and are followed by a linear ion trap 16. Further ion optics 18 are located beyond the ion trap 16, followed by a

- 10 -

curved quadrupolar linear ion trap 22 bounded by gates 20 and 24 at respective ends. This ion trap 22 is the target ion trap in the sense that ions are accumulated here prior to subsequent ejections for mass analysis. An ion reflector 26 is provided adjacent the downstream gate 24. The ion optics 18, ion trap 22 and ion reflector 26 comprise an ion trapping assembly, each of these elements corresponding to a separate volume of that assembly.

The target ion trap 22 is configured to eject ions orthogonally in the direction of the entrance to an Orbitrap mass spectrometer 30 through an aperture provided in an electrode of the target ion trap 22 and through further ion optics 28 that assist in focussing the ion beam emergent from the ion trap 22.

In operation, ions are generated in the ion source 12 and transported through ion optics 14 to be accumulated temporarily in the ion trap 16. Ion trap 16 contains 1 mTorr of helium such that the ions lose some of their kinetic energy in collisions with the gas molecules.

Either after a fixed time delay (chosen to allow sufficient ions to accumulate in the ion trap 16) or after sufficient ions have been detected in the ion trap 16, ions are ejected from the ion trap 16 to travel through ion optics 18 and into the target ion trap 22. Ions with sufficient energy will pass through the target ion trap 22 into the ion reflector 26 where they are reflected to return back to the target ion trap 22. Depending upon the energy of the ions, they may be reflected by the gate 20 or, if they have enough energy to overcome the potential of the gate 20 and continue beyond, by the higher potential of the ion trap 16. This is explained in more detail below.

- 11 -

Cooling gas is introduced into the ion reflector 26 from where it may pass into the target ion trap 22. Nitrogen, argon, helium or any other suitable gaseous substance could be used as a cooling gas, although helium is preferred for the ion trap 16 and nitrogen for the ion trap 22 of this embodiment. This arrangement results in 1 mTorr of nitrogen in the ion reflector 26 and 0.5 mTorr of nitrogen in the target ion trap 22, i.e. the pressure is lower in the target ion trap 22 than in the reflector 26. The pumping arrangement used (indicated by the pumping ports and arrows 32) ensures that the ion optics 18 separating ion trap 16 from target ion trap 22 are substantially free of gas.

Figure 3b shows the potential that exists along the ion path from ion source 12 to ion reflector 26. This potential is created by providing suitable voltages to electrodes present in the ion source 12, ion optics 14 and 18, ion traps 16 and 22, gates 20 and 24, and ion reflector 26. As can be seen, the ions start at a high potential in the ion source 12 and follow a potential that generally decreases to its lowest value in the target ion trap 22, thereby forming a potential well that traps ions as desired in the target ion trap 22.

In fact, the lowest potential is seen in the ion optics 18. As there is no gas within the ion optics 18, ions merely fly through the ion optics 18 without losing energy. Thus, the potential of the ion optics 18 is optimised to ensure minimal ion losses as they pass therethrough. In this case, the potential of the ion optics 18 is less than that of the ion trap 22, such that a raised potential is required therebetween to ensure ions trapped in the target ion trap 22 do not escape to the ion optics 18.

- 12 -

Ions generated by the ion source 12 follow the potential gradient 40 to be trapped in a potential well 44 formed in the ion trap 16 by a higher potential 46 placed on its far end and a drop 42 in potential at its near end. The ions so trapped may lose energy in collisions with the helium in the ion trap 16. Ion trap 16 may also include a detector operable to perform mass analysis experiments.

When sufficient ions have accumulated in the ion trap 16, they are released by lowering the potential 46 from that shown by the dashed line of Figures 3b to that shown by the solid line. Once the ions exit the ion trap 16 and the process of their subsequent storage in ion trap 22 is completed, the potential 46 is increased to correspond to the dashed line. After that, the trap 16 will be ready for filling again. Alternatively, the DC offset of the entire ion trap 16 could be raised, thus stopping ions from re-entering ion trap 16. It is also possible to use ion trap 16 in the transmission mode only, i.e. with potential 46 shown by the solid line set constantly.

A general path of an ion leaving ion trap 16 is shown at 48. The ion traverses the ion optics 18 and target ion trap 22 to enter the ion reflector 26, losing kinetic energy as it goes through collisions with the nitrogen present in the target ion trap 22 and ion reflector 26.

Eventually, the ion will be reflected by the very large potential 48 placed on the ion reflector 26. As can be seen, the potential in ion reflector 26 is arranged to rise exponentially. The once reflected ion again traverses the target ion trap 22 and, because its kinetic energy exceeds the potential 50 on gate 20, continues into ion optics 18 to be reflected by the steep potential gradient 52 between ion trap 16 and ion optics 18. If energy losses in the ion trap

- 13 -

22 and the ion reflector 26 were small enough, the ion could even re-enter ion trap 16, lose some energy in collisions with gas and get reflected by potential barrier 42. Thus, the ion is sent back to the target ion trap 22 to be
5 reflected once more by the potential 48 placed on the ion reflector 26. The ion is reflected back through the target ion trap 22 to be reflected once more by the potential 48 placed on the ion reflector 26.

10 In Figure 3b, the thrice-reflected ion again traverses the target ion trap 22 but has now lost so much energy in collisions with gas molecules that it cannot surmount potential barrier 50 on gate 20. Thus, the ion is reflected back into the target ion trap 22. The potential of gate 24 and the entrance to ion reflector 26 is slightly higher than
15 target ion trap 22: the ion is reflected by the resulting potential gradient 54, thereby becoming trapped within the potential well 56 of the target ion trap 22 that is formed between the gates 20 and 24.

Ions may be accumulated in the target ion trap 22 using
20 only a single or continuous injection of ions from ion trap 16. Alternatively, more ions may be accumulated in the target ion trap 22 by using two or more injections from the ion trap 16. This may be achieved through appropriate
gating of the potential 46 placed on the end of ion trap 16.

25 Once ions are accumulated in the target ion trap 22, they could be manipulated in many different ways, for example:

1. Ions could be transferred back to the ion trap 16 and further processed, e.g. detected on its detector or
30 fragmented, etc. (see below).

- 14 -

2. Ions could be transferred further downstream past ion reflector 26 to further mass analysers or fragmentors, etc.

3. Ions could be pulsed out from to the axis of the target ion trap 22 towards a mass analyser, e.g. orbitrap 30.

For the latter purpose, the potentials 50 and 54 may be raised to those indicated by the dashed peaks 50' and 54' to force the ions towards the middle of the trap 22. Increase of ion energy during such "squeezing" is quickly dissipated in collisions with gas in the target ion trap 22.

Ions accumulated in target ion trap 22 are ejected towards the centre of its curvature as indicated by arrow 58, either through the space between electrodes or through an aperture provided in an electrode. Ejection is facilitated using the method described in WO05/124821A2 and incorporated herein in its entirety. Bunching the ions as described above reduces the width of the ion beam passing through the aperture. The curvature of the target ion trap 22 acts to focus the ions on the entrance aperture of the Orbitrap mass spectrometer 30, and this focusing is assisted by ion optics 28.

The above embodiment provides a pressure gain in that the multiple reflections allow a lower gas pressure to be maintained within the target ion trap 22 to provide the same collisional damping. This pressure gain is approximately equal to the number of reflections and this, in turn, is approximately equal to 0.3 to 0.5 divided by the fraction of ions lost from the ion trapping assembly per pass. The majority of ion losses in any ion trapping assembly are at the apertures provided in the electrodes that generally separate the volumes. Therefore high-transmission ion optics are important for optimum performance, particularly

- 15 -

with respect to the aperture-defining electrodes. With other trapping regions also participating in ion cooling, pressure gain could be significantly higher if those regions have higher gas pressures than that in the target ion trap
5 22.

Preferably, the ion optics should be capable of transporting ions of widely varying energies, such as RF guides and periodic lenses. It has been found experimentally that low ion losses are achieved for RF
10 multipoles of inscribed radius r_0 separated by apertures with inner radius exceeding 0.3 to 0.4 of r_0 and a thickness much less than r_0 .

For example, in the above embodiment, the linear trap 16 is typically 50 to 100 mm long, the ion optics 18 are
15 approximately 300 mm long, the target ion trap 22 has an axial length of about 20 mm, and the ion reflector 26 has a length of around 30 mm. The target ion trap 22 contains nitrogen at 0.5 mTorr giving a $P \times D = 0.01$ mm Torr, the ion reflector contains nitrogen at 1 mTorr giving a $P \times D = 0.03$
20 mm Torr.

The internal diameters of the apertures provided in gates 20 and 24 are 2.5 to 3 mm, while their thicknesses are no more than 1 mm. Inscribed diameters of the linear ion trap 16 is 8 mm, of the target curved linear ion trap 22 is
25 $2 \times r_{clt} = 6$ mm, and of the ion optics 18 is 5.5 mm. Typically, trapping occurs on the timescale of few ms.

Overall, a low pressure in the target in trap 22 is desirable to allow safe pulsing-out of fragile ions orthogonally, as well as for more efficient differential
30 pumping on the way to Orbitrap mass analyser 30. To avoid fragmentation of ions at high energies, $P_{clt} \times r_{clt} < 10^{-3}$ to

- 16 -

10^{-2} mm Torr is required (depending on mass, charge, structure and other parameters of ions). With $r_{clt}=3$ mm, this means $P_{clt} < (0.3 \text{ to } 3) \times 10^{-3}$ Torr.

The pressure gain provided by the above embodiment has been seen to improve performance. Previously, a noticeable performance loss was observed in ion traps above m/z 500: now, no loss in performance is observed up to m/z 2000.

The above described embodiment is but merely one possible implementation of the present invention. The reader skilled in the art will appreciate that variations to this embodiment are possible without departing from the scope of the present invention.

For example, Figures 4a to 4e show different arrangements of ion optics and ion traps that may be used. Figure 4a shows a simple ion trapping arrangement of ion optics 60 followed by a target ion trap 62. Ions are generated by an ion source (not shown) to be injected into the ion optics 60 at 64. The ions are reflected at the ends of the ion trapping arrangement, as indicated by arrows 66 and 68. Target ion trap 62 contains a gas to effect gas-assisted trapping. Ion optics 60 are kept at a higher potential than that of ion target trap 62. Ions that become trapped in the potential well of target ion trap 62 may be ejected either axially as indicated at 70 or orthogonally as indicated at 72.

Figure 4b shows an ion trapping arrangement comprising a target ion trap 80 sandwiched between two sets of ion optics 82 and 84. Ion optics 84 act as an ion reflector. Ions are injected at 86 to be reflected by the ends of ion optics 82 and 84, as indicated at 88 and 90. The target ion trap 80 contains a gas. Trapped ions collect in a potential well formed by the target ion trap 80 and may be ejected

- 17 -

orthogonally at 92 or axially via the ion optics 84, as indicated at 94.

Figure 4c shows an ion trapping arrangement where ions injected at 100 pass through ion optics 102, gas-filled ion trap 104, ion optics 106 and gas-filled target trap 108 in turn. Ions are reflected by the far end of target trap 108 at 110 and by the far end of ion traps 104 at 112. Ions trapped in the potential well provided by the target ion trap 108 may be ejected either axially at 114 or orthogonally at 116.

Figure 4d shows an ion trapping arrangement where ions injected at 120 pass through ion optics 122, gas-filled ion trap 124, ion optics 126, gas-filled target ion trap 128 and ion reflector 130. Ions are reflected by ion reflector 130 at 132 and the far end of ion trap 124 at 134. Ions trapped in the potential well provided by the target ion trap 128 may be ejected either orthogonally from the trap 128 at 136 or axially via ion reflector 130 at 138.

Figure 4e corresponds substantially to Figure 4d, except that both target ion trap 128 and ion reflector 130 are filled with gas. Thus, the ion trapping arrangement of Figure 4e is the same as that shown in Figure 3a. It is important to notice that in all embodiments of the current invention, collisions on a single ion pass through the target ion trap 22 result in capture of a substantially negligible proportion of the ion beam, typically <10%. Applying the invention, capture efficiency improves as compared to a single-pass by at least 2-5 fold. This distinguishes this invention from numerous known types of single- and multiple-trap arrangements.

The described principle of trapping is applicable to any type of traps regardless of their construction and thus

- 18 -

includes: extended sets of electrodes or multipoles, apertures of constant or varying diameters, spiral or circular electrodes with RF and DC applied potentials, magnetic and electromagnetic traps, etc. While the use of gas-assisted trapping is preferred, other arrangements such as adiabatic trapping may also be employed. Also, ion trap potentials may be increased to effect ion cloud compression within the ion trap.

Where gas-assisted trapping is being used, the choice of gases that are used may be freely varied, as may the pressures at which these gases are maintained. Reactive gases (such as methane, water vapour, oxygen, etc.) or non-reactive gases (such as noble gases, nitrogen, etc.) could be also used when desired.

Other uses of proposed trapping method might be envisaged. For example, the arrangement of Figure 3a or Figure 4b could be used to increase the trapping efficiency of incoming ions from the ion source 12 without the need for increasing the length (and thus the cost) of the ion trap 16 or 104, respectively. In this case, most of ions could be trapped in the target trap 22 or 108 initially, and subsequently transferred back to the ion trap 16 or 104.

Generally, ions could be moved from one ion trap to another just by changing DC offsets on the ion traps 16 and 22, and ion optics 14 and 18. In this sense, the term "target trap" should be construed to mean the target for where the ions are to be trapped using collisional cooling (as opposed to the final ion trap used for storage prior to mass analysis). This also allows diagnostics and minimisation of ion losses. For example, a fixed number of ions could be transferred from ion trap 16 into ion trap 22, then back into ion trap 16 and then measured using a

- 19 -

detector or detectors provided in the ion trap 16.

Comparison of mass spectra collected by the same detector(s) with and without transfer to the ion trap 16 allows accurate measurement of ion transmission for each mass peak.

5 Another possibility opened by multi-pass trapping is the splitting of ion beams. For example, if two ion traps have exactly the same DC offset and no potential barriers separating them, the ion cloud will be distributed between these traps. Creating a potential barrier between the ion
10 traps would split the ion population in two. This could be useful when different detectors are employed in each of the traps as it would allow better cross-calibration of each detector and better quantitative analysis. For example, a first part of the ion population could be split into a first
15 part of the target ion trap 22 and trapped there before being measured by an associated detector. The measured ion number could be then used for predicting the exact number of ions stored in the second part of the target ion trap 22 that may be subsequently ejected to the orbitrap 30. This
20 allows corrections to be applied to the mass calibration in mass spectra acquired in the orbitrap 30. This would be advantageous when used with relatively unstable sources, such as MALDI.

As any of the ion traps within the embodiments
25 described above could be operated as the target ion trap if potentials are set appropriately, it means also that each of the ion traps could be interfaced to another mass analyser either axially or orthogonally, as shown schematically by dashed arrows in Figure 4. Such mass analysers are
30 preferably of TOF, FT ICR, electrostatic trap or any ion trap types, but quadrupole mass analysers, ion mobility spectrometers or magnetic sectors could also be used. Mass

- 20 -

analysers could form an integral part of any ion optics shown in Figures 3 or 4.

The above has been described in the context of trapping positive ions. However, the skilled person will appreciate that the present invention lends itself just as readily to trapping negative ions. Although adaptation of potentials (polarities in particular) will be required, such adaptation is straightforward and well within the skill of the ordinary skilled person.

In fact, the present invention may be used to trap ions of both polarities simultaneously, provided that potential barriers are used that can trap both polarities. Such potential barriers may be created by the "pseudo-potential" (otherwise known as the "effective potential") of RF fields (similar to an RF field that holds ions of any polarity in an ion trap). For example, an RF voltage may be applied to apertures at the end(s) of the target trap 22, or there may be an RF voltage between offsets of two multipoles, etc.

When ions move in RF fields, their motion may be considered as a high-frequency ripple at the frequency of the RF field, superimposed on a smooth "averaged" trajectory. As shown by Landau and Lifshitz (Mechanics, Pergamon Press, Oxford, UK, 1969), the motion of ions with a mass-to-charge ratio m/q along such "smoothed" trajectories is equivalent under certain conditions (e.g. when the ripple is relatively small) to the motion in the pseudo-potential:

$$U_{eff}(r, z) = \frac{1}{2 \cdot m / q} \cdot \left\langle \left| \int_t \nabla \Phi dt \right|^2 \right\rangle$$

- 21 -

where $\langle \dots \rangle$ means averaging over the period of the RF field, $|\dots|$ means the modulus of the vector, and $\nabla\Phi$ is the gradient of the RF potential. Pseudo-potentials may be used to create potential wells or barriers as effectively as DC potentials. The pseudo-potential is proportional to the average of the field gradient squared and inversely proportional to m/q , and so will exhibit strong mass dependency. The strong mass dependency of pseudo-potential could be used to advantage when mass selection is required. The major difference is that pseudo-potential wells or barriers work in the same way on both negative and positive charged particles, thus allowing ions of both polarities to be trapped simultaneously. Pseudo-potentials may also be combined with DC potentials. Obviously, pseudo-potentials could be also used to trap ions of one polarity only.

In the embodiments above, an RF voltage could be switched on at the end apertures of the target trap 22 or even between RF multipoles (e.g. on top of a DC offset of a multipole) when ion trapping is required. As an example, positive ions could be stored near one end of the target trap 22 using only DC potential wells. Then negative ions could be admitted from an additional ion source or even from the same ion source 12 (after voltage polarity is reversed along all of the ion path except the target trap 22) and stored near the other end of the target trap 22. Ions may be introduced from further ion sources. After that, RF is switched on at both ends of the target trap 22 and DC potential wells are removed. Ions of both polarities start to share the same trapping volume and attract to each other resulting in ion-ion interactions for example as described in WO2005/090978 and WO2005/074004.

20086-2323

- 22 -

CLAIMS:

1. A method of trapping ions in a target ion trap comprising:

introducing ions into an ion trapping assembly comprising a series of
volumes arranged such that ions can traverse from one volume to the next, the
5 volumes including the target ion trap;

allowing the ions to pass into, through and out from the target ion trap
without being trapped, and into a volume adjacent the target ion trap without being
trapped, the target ion trap and the adjacent volume being separated by an electrode
defining an aperture; and

10 guiding the ions such that they pass into the target ion trap for a second
time.
2. The method of claim 1, comprising reflecting the ions such that they
pass into the target ion trap for the second time.
3. The method of claim 2, further comprising reflecting the ions a second
15 time such that the ions pass into the target ion trap for a third time.
4. The method of claim 3, comprising placing a first potential at one end of
the ion trapping assembly and placing a second potential at the other end of the ion
trapping assembly, thereby causing the ions to reflect at either end and so to traverse
the target ion trap repeatedly.
- 20 5. The method of claim 4, wherein an end of the target ion trap
corresponds to an end of the ion trapping assembly.
6. A method of gas-assisted trapping of ions in a target ion trap of an ion
trapping assembly comprising a series of volumes arranged such that ions can
traverse from one volume to the next, the volumes including the target ion trap and a

20086-2323

- 23 -

volume adjacent the target ion trap, separated by an electrode defining an aperture, the method comprising:

filling at least the volume corresponding to the target ion trap with gas;

applying potentials to the ion trapping assembly such that (i) the

- 5 potential rises at either end of the target ion trap, thereby forming a potential well in the target ion trap, (ii) any of the one or more gas-filled volumes adjacent the target ion trap are at a higher potential than the target ion trap, and (iii) potential barriers are formed at either end of the ion trapping assembly; and

introducing ions into the ion trapping assembly where they are

- 10 subsequently reflected by the potential barriers at either end of the ion trapping assembly, thereby traversing the target ion trap repeatedly to settle in the potential well as their energy decreases without being trapped in the volume adjacent the target ion trap.

7. The method of any one of claims 1 to 6, further comprising introducing a
15 gas into at least one of the volumes thereby causing gas-assisted trapping of the ions.

8. The method of claim 7 or claim 1, comprising introducing a gas into the target ion trap.

9. The method of claim 8, further comprising introducing a gas into the
20 volume adjacent the target ion trap.

10. The method of claim 9, comprising introducing the gas or gases into the target ion trap and the adjacent volume such that the pressure in the target ion trap is lower than in the adjacent volume.

11. The method of any one of claims 1 to 10, further comprising applying a
25 potential to the electrode separating the target ion trap and the adjacent volume.

20086-2323

- 24 -

12. The method of any one of claims 1 to 10, further comprising applying RF potentials to the ion trapping assembly to produce pseudo-potentials for trapping ions.
13. The method of claim 12, comprising applying RF potentials suitable for trapping both positive and negative ions simultaneously.
14. The method of any one of claims 8 to 13, wherein at least some of the series of volumes are gas-filled volumes, the method further comprising applying potentials to the ion trapping assembly such that the target ion trap is at the lowest potential of the gas-filled volumes.
15. The method of any one of claims 8 to 14, wherein at least some of the series of volumes are gas-filled volumes, the method further comprising filling the gas-filled volumes such that the product of the average pressure in the ion trapping assembly by the length of the ion trapping assembly is less than 0.5 Torr*mm.
16. The method of claim 15, comprising filling the gas-filled volumes such that the product is less than 0.2 Torr*mm.
17. The method of any one of claims 8 to 16, comprising operating the gas-filled volume at a pressure in the range 0.1 mTorr to 10 mTorr.
18. The method of claim 17, comprising operating the gas-filled volume at a pressure in the range 0.5 mTorr to 2 mTorr.
19. The method of any one of claims 1 to 18, further comprising trapping ions in an ion store before releasing ions from the ion store into the ion trapping assembly.
20. The method of claim 19, comprising repeatedly trapping ions in the ion store and releasing them into the ion trapping assembly thereby to increase successively the number of ions in the target ion trap.

20086-2323

- 25 -

21. The method of claim 20, further comprising applying potentials to either end of the ion store to trap ions therein, and then lowering the potential at one end thereby releasing ions from that end into the ion trapping assembly.

22. The method of any one of claims 19 to 21, comprising applying
5 potentials to the ion store such that it is at a higher potential than the ion trapping assembly.

23. The method of any one of claims 1 to 22, wherein the ion trapping assembly has a longitudinal axis corresponding broadly to the ions' motion backwards and forwards through the series of volumes and the method further
10 comprising ejecting ions trapped in the target ion trap substantially orthogonally from the target ion trap.

24. The method of any one of claims 1 to 23, wherein the target ion trap comprises one of the volumes.

25. The method of any one of claims 1 to 23, wherein the target ion trap
15 comprises first and second volumes of the series of volumes, the method comprising:

applying potentials to the ion trapping assembly such that the potential rises at either end of the target ion trap thereby forming a potential well, and such that potential barriers are formed at either end of the ion trapping assembly;

introducing ions into the ion trapping assembly where they are
20 subsequently reflected by the potential barriers at either end of the ion trapping assembly, thereby traversing the target ion trap repeatedly while they lose energy eventually to settle in the target ion trap; and

subsequently to apply a potential to act between the first and second volumes thereby to split the ions that have settled in the target ion trap into two
25 groups, one being trapped in the first volume and the other being trapped in the second volume.

20086-2323

- 26 -

26. The method of claim 25, wherein the first and second volumes are adjacent one another.

27. The method of claim 25 or claim 26, further comprising determining the number of ions in the first volume and using this determination to estimate the
5 number of ions in the second volume.

28. The method of claim 27, further comprising ejecting the ions trapped in the second volume to a mass spectrometer, acquiring a mass spectrum from the ions, and assigning masses to peaks in the mass spectrum in accordance with the estimated number of ions in the second volume.

10 29. An ion trapping assembly comprising:

a series of volumes arranged such that ions can traverse from one volume to the next, wherein some of the volumes are adapted to be filled with gas, and wherein the series of volumes include a target ion trap and a volume adjacent the target in trap, separated by an electrode defining an aperture;

15 electrodes arranged to carry potentials; and

a controller arranged to set potentials on the electrodes such that, at the same time, (i) the potential rises at either end of the target ion trap, thereby forming a potential well in the target ion trap, (ii) the one or more volumes adapted to be filled with gas adjacent the target ion trap are at a higher potential than the target ion trap,
20 and (iii) potential barriers are formed at either end of the ion trapping assembly.

30. The ion trapping assembly of claim 29, comprising ion optics corresponding to one of the volumes located adjacent the target ion trap.

31. The ion trapping assembly of claim 29 or claim 30, comprising an ion reflector corresponding to one of the volumes located adjacent to the target ion trap.

20086-2323

- 27 -

32. The ion trapping assembly of any one of claims 29 to 31, wherein the controller is arranged to set potentials to produce pseudo-potentials for trapping ions.

33. The ion trapping assembly of claim 32, wherein the controller is operable to set potentials to produce pseudo-potentials to trap both positive and
5 negative ions simultaneously.

34. The ion trapping assembly of any one of claims 29 to 33, further comprising a gas supply operable to introduce a gas into at least one of the volumes.

35. The ion trapping assembly of any one of claims 29 to 34, wherein the target ion trap comprises one of the volumes.

10 36. The ion trapping assembly of any one of claims 29 to 35, wherein the target ion trap comprises first and second volumes of the series of volumes, and the controller is arranged to allow a delay for ions to settle in the potential well of the target ion trap and then to set a potential to act between the first and second
15 volumes, thereby forming two potential wells, one in each of the first and second volumes.

37. The ion trapping assembly of claim 36, wherein the first and second volumes are adjacent one another.

38. An ion source and trapping assembly, comprising an ion source, an ion store positioned downstream of the ion source, and the ion trapping assembly of any
20 one of claims 29 to 37 positioned downstream of the ion store.

39. The ion source and trapping assembly of claim 38, wherein the controller is arranged to set potentials on the ion store to trap ions produced by the ion source and then to release trapped ions into the ion trapping assembly.

40. The ion source and trapping assembly of claim 39, wherein the
25 controller is arranged to set potentials to either end of the ion store to trap ions

20086-2323

- 28 -

therein, and then to lower the potential at one end thereby releasing ions from that end into the ion trapping assembly.

41. The ion source and trapping assembly of claim 39 or claim 40, wherein the controller is arranged to trap ions in the ion store repeatedly, each time releasing
5 the ion packet into the ion trapping assembly thereby accumulating multiple ion packets in the target ion trap.

42. The ion source and trapping assembly of any one of claims 38 to 41, wherein the controller is arranged to apply potentials to the ion store such that it is at a higher potential than the ion trapping assembly.

10 43. The ion source and trapping assembly of any one of claims 38 to 42, wherein the ion trapping assembly has a longitudinal axis corresponding broadly to the ions motion backwards and forwards through the series of volumes and the controller is arranged to eject ions trapped in the target ion trap substantially orthogonally from the target ion trap.

15 44. A mass spectrometer comprising the ion trapping assembly of any one of claims 29 to 37.

45. A mass spectrometer comprising the ion source and trapping assembly of any one of claims 38 to 43.

1 / 3

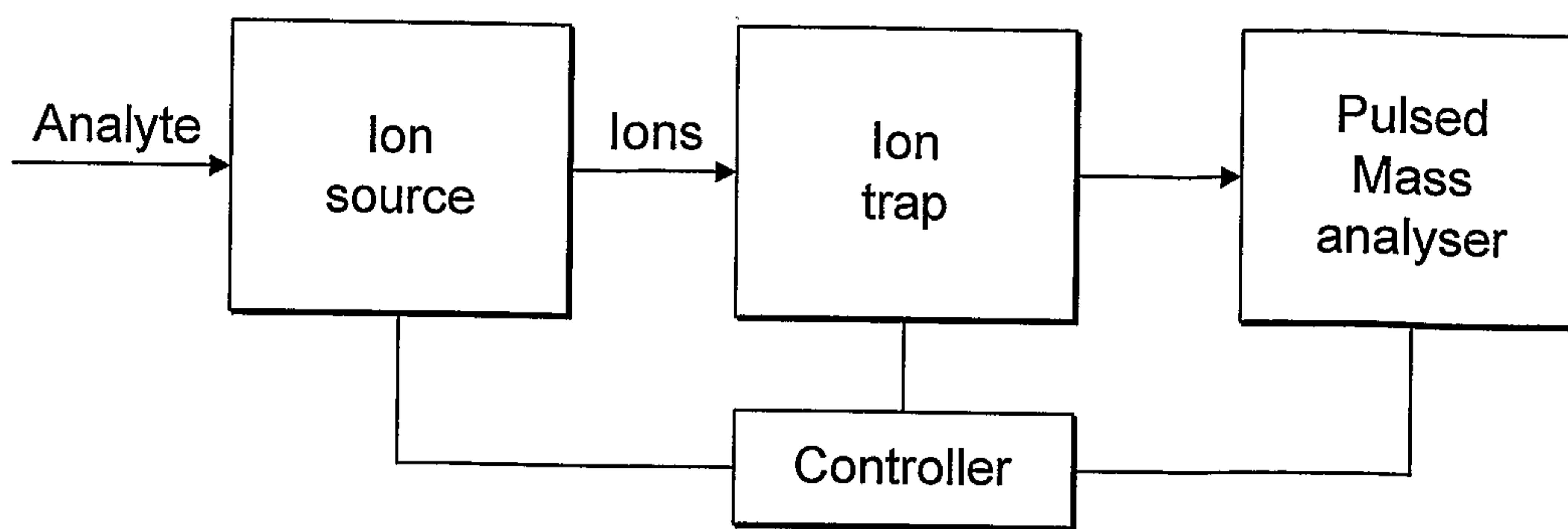

FIG. 1

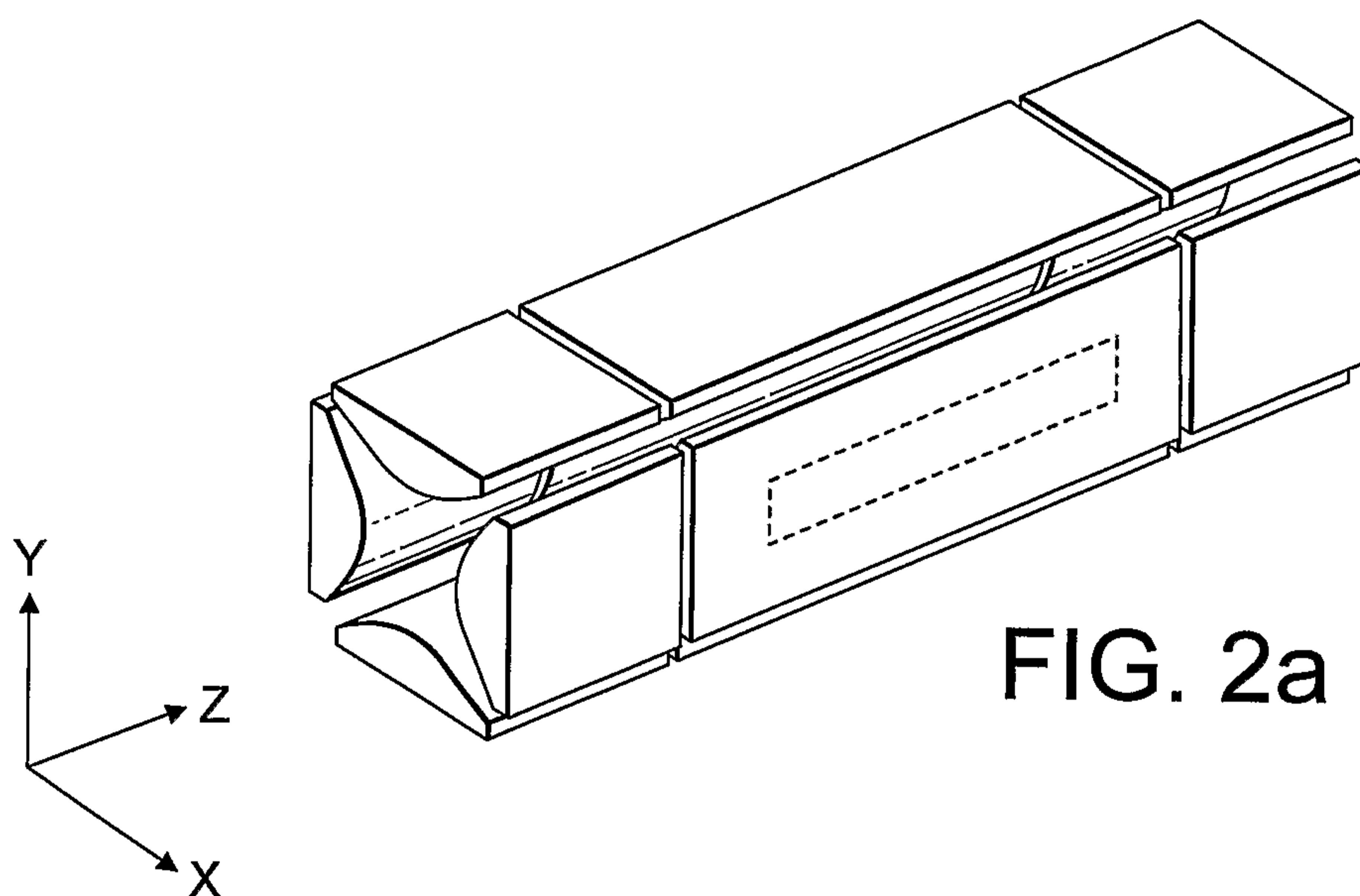

FIG. 2a

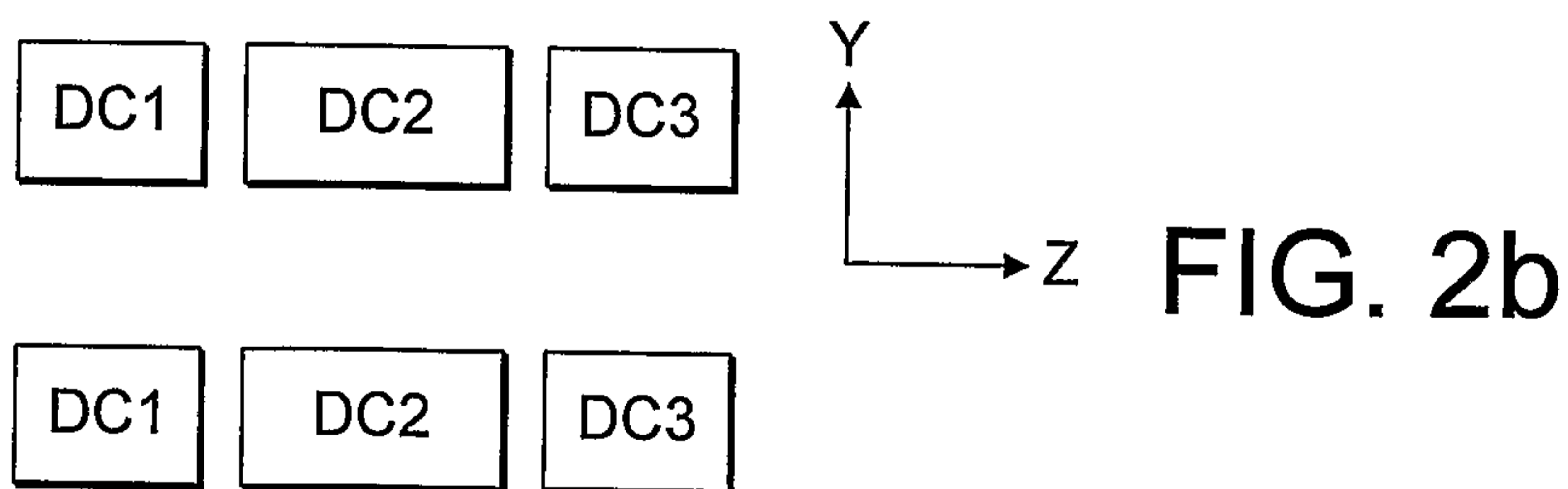

FIG. 2b

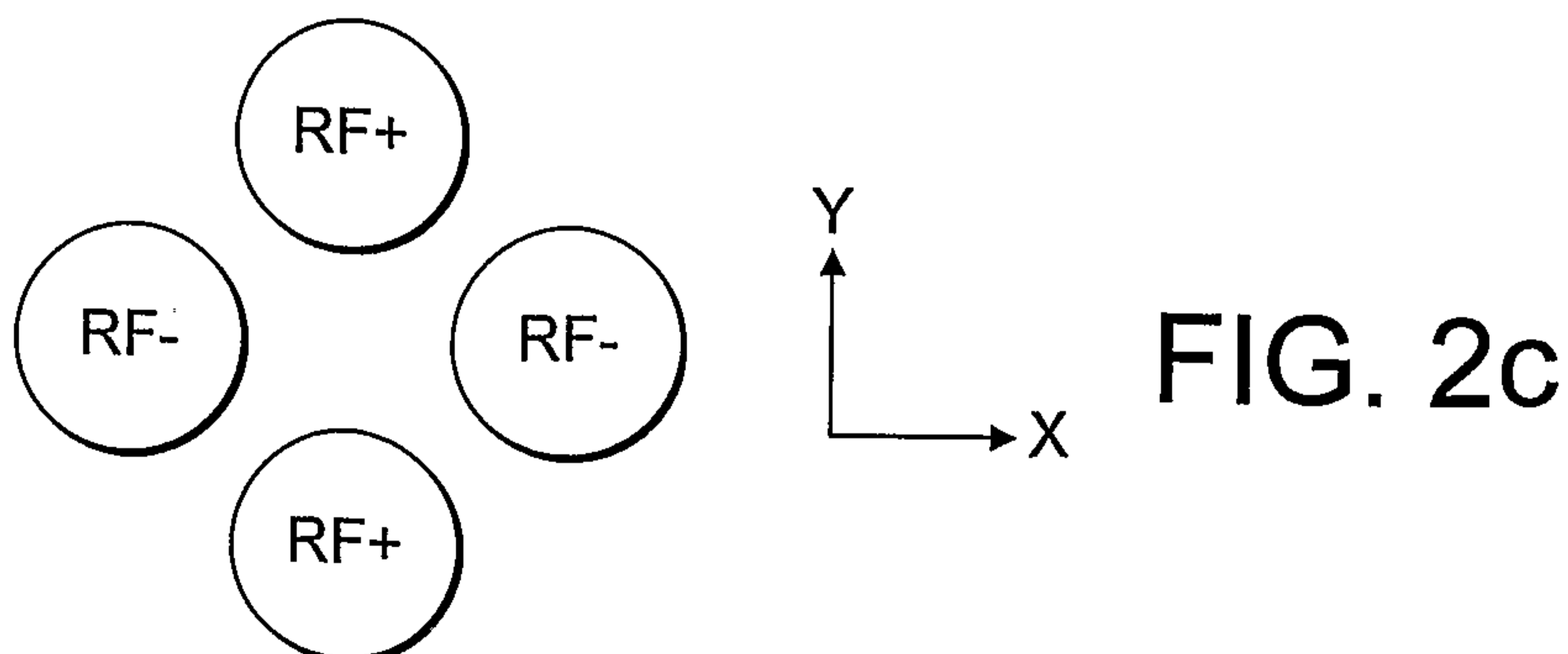

FIG. 2c

