

(No Model.)

R. WILKINSON.  
CAR FENDER.

No. 559,091

Patented Apr. 28, 1896.

Fig. 1.

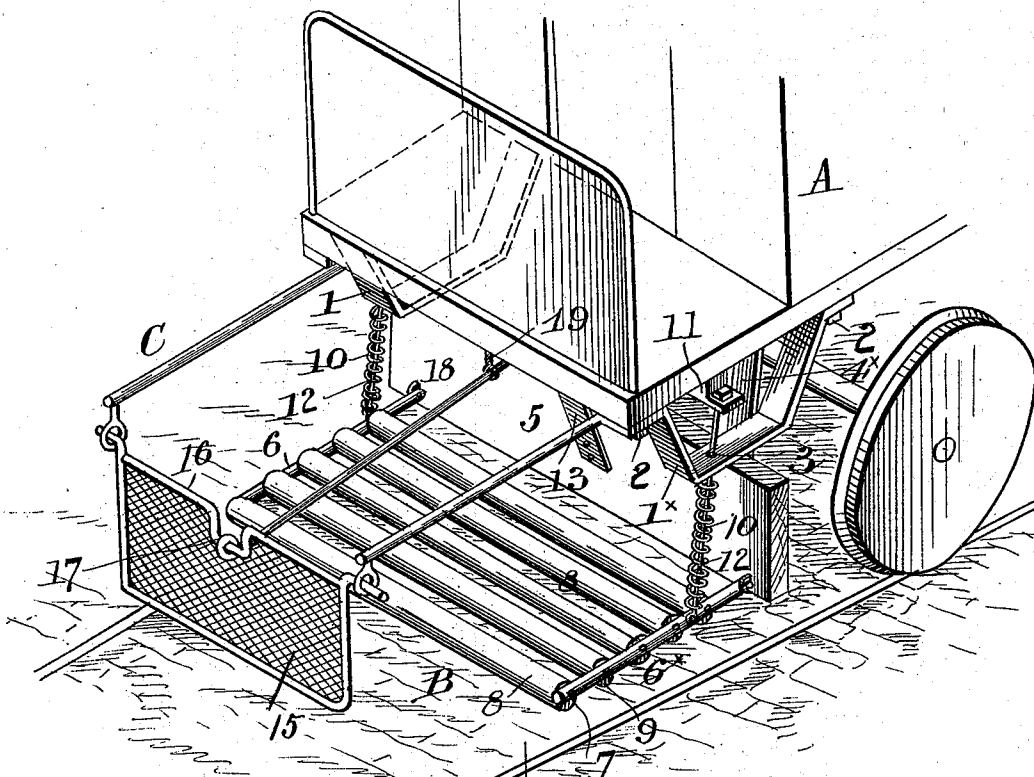
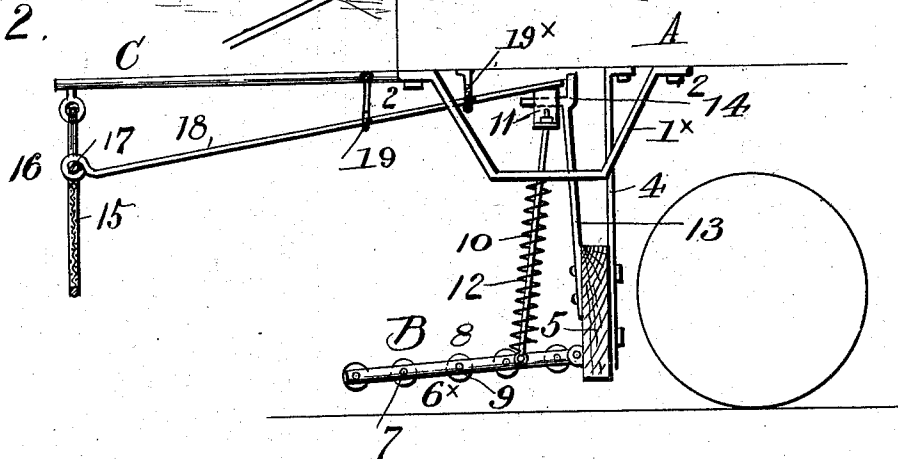

Fig. 2.



Witnesses:  
F. L. Ormand  
A. J. Smith

Inventor  
Robert Wilkinson  
By D. B. Williams  
Attorney

# UNITED STATES PATENT OFFICE.

ROBERT WILKINSON, OF PHILADELPHIA, PENNSYLVANIA.

## CAR-FENDER.

SPECIFICATION forming part of Letters Patent No. 559,091, dated April 28, 1896.

Application filed January 21, 1896. Serial No. 576,307. (No model.)

*To all whom it may concern:*

Be it known that I, ROBERT WILKINSON, a citizen of the United States, residing at Philadelphia, in the county of Philadelphia and State of Pennsylvania, have invented certain new and useful Improvements in Car-Fenders; and I do declare the following to be a full, clear, and exact description of the invention, such as will enable others skilled in the art to which it appertains to make and use the same.

My invention has relation to car-fenders; and the object is to construct and provide a car-fender operated by means of a guard placed in advance of the fender, which is struck and moved by the impediment, object, or person, as will be hereinafter fully described, and the novelty specifically pointed out in the claims.

I have fully and clearly illustrated my invention in the accompanying drawings, forming a part of this specification, and wherein—

Figure 1 is a perspective of my improved car-fender connected to a car. Fig. 2 is a side view of the same.

A designates the body and bottom of a portion of a car, carried on trucks, as usual, only one set of the wheels of the truck being shown. To the timbers of the car-bottom, on each side of the car and arranged opposite to each other, are two suitable hangers 1 1<sup>x</sup>, preferably of the shape shown, which are secured by bolts 2, let through extensions of the arms of the hangers. In the bridge or bar of the hangers, at the lower ends thereof, is a hole 3 to receive the sliding side rods of the fender.

To the bottom of the car are secured the upper ends of two depending bars or rods 4 4<sup>x</sup>, having secured to the lower portions thereof a substantial cross-plate 5, of any suitable material, constituting an abutment and wheel-guard. To the lower front edge face of the cross-plate 5 is pivotally hung the fender B, consisting of substantial side bars 6 6<sup>x</sup>, formed with a plurality of bearing-holes 7, in which are journaled the ends of the round bars 8 of the fender.

The cross-bars 8 of the fender consist of round metal bars of greater diameter than the width of the side bars 6 6<sup>x</sup>, in order that when the fender is lowered to contact with the surface the perimeter of the forward bars

will bear on the surface and be rotated by the progression of the car, and also in order that when a body or other object is thrown on the fender it will strike on the revoluble bars, and thus be relieved from the serious consequences attending the impact of a fixed and non-revoluble bar. The ends of the bars 8 are reduced in size to form the requisite journals, as seen at 9, which are arranged in the bearings 7 of the side bars of the fender, the journals being secured in the bearings by any proper means.

To each side bar of the fender, at about midway of the length of the bars, is pivotally secured the lower end of a bar 10, which passes loosely up through the hole 3 in the hangers, and having the upper ends suitably fastened to the ends of a strong cross-bar 11. On each bar 10 is arranged a spiral spring 12, the lower end of which rests on the fender and the upper end abutting against the under face of the hanger.

It will be perceived from the foregoing description, taken in connection with the drawings, that when a fender is raised the springs 12 will be compressed, and consequently when the fender is released and becomes free to move downward the force of the springs will expedite the movement and throw the fender quickly down to surface contact. It will also be perceived that when the fender is raised and the cross-bar is lodged on the retaining-spring the force of the springs will keep the cross-bar in the seat in the retaining-spring and prevent it from becoming dislodged by the jars and the movements of the car, and thus hold the fender raised from contact with the surface. On the board or plate 5 is firmly secured the lower end of a plate-spring 13, the stem of which is inclined forward and on the top is formed or provided with an angular catch-piece 14, arranged with one arm projecting horizontally and the other in vertical direction, substantially as shown, the horizontal arm constituting a seat in which the cross-bar of the fender engages and lies and the vertical arm thereof constituting an abutment or stop to prevent the cross-bar from being thrown back over and back of the holding-spring.

To the front end of the car is suitably hung a metal frame C, constituting a guard, cov-

ered with a strong netting of suitable material, as 15. The upper bar 16 of this frame at the middle is formed with a crank-bail 17, to which is connected one end of a connecting-rod 18, led through hangers 19 19<sup>x</sup>, depending from the car-floor, and having its other end resting adjacent to the vertical arm of the cross-bar seat in the top of the supporting-spring 13, as seen in the drawings. It will be perceived that when an object strikes against the frame or guard C it will be swung inward, and through the instrumentality of the crank-arm the connecting-rod will be pushed backward, carrying with it the supporting-spring, dislodging the cross-bar and permitting the fender to drop down into contact with the surface of the road-bed and track into a position to pick up the object and carry it back on the fender.

20 Having thus described my invention, what I claim, and desire to secure by Letters Patent, is—

1. In a car-fender, the combination of a pivotally-supported fender, hangers on the car-body having holes in their lower ends, spring-actuated bars having their lower ends pivotally connected to the fender midway of the side bars thereof, and their stems passed loosely through the holes in the hangers and connected by a cross-bar at their upper ends, a spring-catch to hold the cross-bar up, a

netted guard-frame hung to the rear end of the car, and a sliding bar having one end secured to the said guard-frame, and arranged to engage the spring-catch and push it from under the cross-piece, substantially as described.

2. In a car-fender, the combination of two depending bars from the car-body, a cross-plate connecting the lower ends of the depending bars, a fender jointed to the cross-plate, oppositely-arranged hangers formed with holes in their lower ends, vertical bars having their lower ends connected to the fender, and having their stems passed through the holes in the hangers, and their upper ends connected by a cross-bar, springs arranged on the vertical bars between the hangers and the fender, a spring having its lower end secured to the cross-plate and its upper free end formed with a seat to hold the cross-bar, a netted guard-frame hung to the front end of the car and having its upper bar formed with a crank-bail, and a connecting-rod between the crank-bail and the supporting-spring, substantially as specified.

In testimony whereof I hereunto affix my signature in presence of two witnesses.

ROBERT WILKINSON.

Witnesses:

JOHN M. CARROLL,  
JOHN MCCONNELL.