



- (51) International Patent Classification:
H04L 12/24 (2006.01) *G06K 19/067* (2006.01)
- (21) International Application Number:
PCT/CN2011/072312
- (22) International Filing Date:
30 March 2011 (30.03.2011)
- (25) Filing Language: English
- (26) Publication Language: English
- (71) Applicant (for all designated States except US):
SIEMENS AKTIENGESELLSCHAFT [DE/DE]; Witel-
telsbacherplatz 2, 80333 Munich (DE).
- (72) Inventors; and
- (75) Inventors/Applicants (for US only): XU, Leiming
[CN/CN]; 6-1-401, Hua Jia Di Xiao Qu, Wangjing, Chaoy-
ang District, Beijing 100102 (CN). AVERBECK, Robert
[DE/DE]; Almbachstr.13, 81379 Muenchen (DE). QIU,
Wei [CN/CN]; Room B-7-1-402, Xi Er Qi Zhong Lu No.
6, Haidian District, Beijing 100086 (CN). KRAUS, Ro-
land [DE/DE]; Alpspitzstr.11, 82031 Gruenwald (DE).
- (74) Agent: KANGXIN PARTNERS, P.C.; Floor 16, Tower
A, InDo Building, A48 Zhichun Road, Haidian District,
Beijing 100098 (CN).

- (81) Designated States (unless otherwise indicated, for every
kind of national protection available): AE, AG, AL, AM,
AO, AT, AU, AZ, BA, BB, BG, BH, BR, BW, BY, BZ,
CA, CH, CL, CN, CO, CR, CU, CZ, DE, DK, DM, DO,
DZ, EC, EE, EG, ES, FI, GB, GD, GE, GH, GM, GT, HN,
HR, HU, ID, IL, IN, IS, JP, KE, KG, KM, KN, KP, KR,
KZ, LA, LC, LK, LR, LS, LT, LU, LY, MA, MD, ME,
MG, MK, MN, MW, MX, MY, MZ, NA, NG, NI, NO, NZ,
OM, PE, PG, PH, PL, PT, RO, RS, RU, SC, SD, SE, SG,
SK, SL, SM, ST, SV, SY, TH, TJ, TM, TN, TR, TT, TZ,
UA, UG, US, UZ, VC, VN, ZA, ZM, ZW.
- (84) Designated States (unless otherwise indicated, for every
kind of regional protection available): ARIPO (BW, GH,
GM, KE, LR, LS, MW, MZ, NA, SD, SL, SZ, TZ, UG,
ZM, ZW), Eurasian (AM, AZ, BY, KG, KZ, MD, RU, TJ,
TM), European (AL, AT, BE, BG, CH, CY, CZ, DE, DK,
EE, ES, FI, FR, GB, GR, HR, HU, IE, IS, IT, LT, LU, LV,
MC, MK, MT, NL, NO, PL, PT, RO, RS, SE, SI, SK, SM,
TR), OAPI (BF, BJ, CF, CG, CI, CM, GA, GN, GQ, GW,
ML, MR, NE, SN, TD, TG).

Published:

— with international search report (Art. 21(3))

(54) Title: A METHOD FOR CONFIGURING A WIRELESS DEVICE AND A WIRELESS DEVICE AND SYSTEM

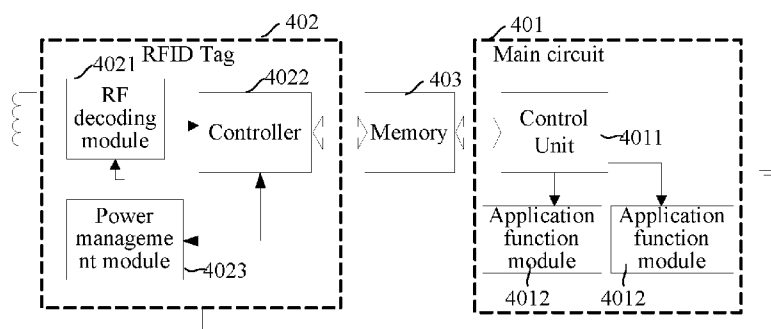

Figure 4

(57) Abstract: Embodiments of the present invention provide a method for configuring a wireless device, where, the wireless device is embedded with a Radio Frequency Identification (RFID) tag or connected with an RFID tag, the method includes: obtaining, by the RFID tag, configuration data from a Radio Frequency (RF) signal; and, configuring, by the RFID tag, according to the obtained configuration data. The embodiments of the present invention also provide a corresponding wireless system and a wireless device. By adopting the embodiments of the present invention, the wireless device can be effectively configured with low costs.



A METHOD FOR CONFIGURING A WIRELESS DEVICE AND A WIRELESS DEVICE AND SYSTEM

Field of the Invention

The present invention relates to Wireless Sensor Network (WSN) technologies, and
5 in particular, to a method for configuring a wireless device, and a wireless device and system applied with this method.

Background of the Invention

A Wireless Sensor Network (WSN) consists of spatially distributed autonomous
sensors to cooperatively monitor physical or environmental conditions, such as
10 temperature, sound, vibration, pressure, motion or pollutants. Wireless sensor networks are now used in many industrial and civilian application areas, including industrial process monitoring and control, machine health monitoring, environment and habitat monitoring, healthcare applications, home automation, and traffic control.

In addition to one or more sensors, each sensor node in a wireless sensor network is
15 typically equipped with a radio transceiver or other wireless communications device, a small microcontroller, and an energy source, usually a battery, and a device acting as the sensor node may be called a wireless sensor. In many cases, the wireless sensor network works as an infrastructure, embedded into working field such as environment, buildings or etc., with no need of maintenance, where, the wireless sensor needs to be
20 battery-power-supplied and work without user intervention, and usually, the wireless sensor becomes un-touchable after it is installed in a working field. For example, when a wireless sensor network is applied to a parking monitor system, battery-supplied wireless sensors are mounted under the ground surface of a parking field to detect presence of vehicles and report status to a management node through wireless. Usually, these wireless
25 sensors are covered by a shell of some material, e.g., epoxy or etc., to provide protection, and its housing is usually permanently sealed and has not external interface to provide enough protection. Thus, these wireless sensors become un-touchable once they are mounted underground.

Generally, it is needed to perform initial configuration on a wireless device at its startup time, and further, it is also possible to perform re-configuration during its running time. However, it is very difficult to realize either the initial configuration or the re-configuration on the aforementioned un-touchable wireless device, and fixed configuration is usually set for such un-touchable wireless device just when it is delivered from factory. Meanwhile, when the wireless device is delivered from factory and applied to a specific working field, the fixed configuration usually can not satisfy requirements of practical working, and needs to be re-configured. At present, there is no solution provided for the above problem in the prior art.

10 **Summary of the Invention**

Aspects of the present invention provide a method for configuring a wireless device, where, the wireless device is embedded with a Radio Frequency Identification (RFID) tag or connected with an RFID tag, the method includes: utilizing, by the wireless device, the RFID tag to obtain configuration data from a Radio Frequency (RF) signal; and, configuring, by the wireless device, according to the obtained configuration data.

In an aspect of the present invention, the RF signal is received by the RFID tag and decoded to obtain the configuration data. In this aspect of present invention, the method further includes: storing the configuration data obtained by the RFID tag; and, in this aspect of present invention, the stored configuration data is read by the wireless device to accomplish initial configuration upon power on; and/or, to accomplish re-configuration during running time.

In an aspect of the present invention, when the RFID tag is a passive RFID tag, the method further includes: obtaining, by the passive RFID tag, power from the RF signal.

In an aspect of the present invention, the wireless device includes a wireless sensor in a wireless sensor network.

In an aspect of the present invention, the configuration data at least include: configuration data related with wireless links, and/or configuration data related with sensors.

An aspect of the present invention also provides a wireless device which includes a main circuit and a Radio Frequency Identification (RFID) tag; wherein: the RFID tag is adapted to obtain configuration data from a Radio Frequency (RF) signal; and, the main circuit is adapted to configure according to the configuration data obtained by the RFID

tag.

In an aspect of the present invention, the wireless device further includes: a memory, adapted to store the configuration data obtained by the RFID tag; wherein, the main circuit is adapted to read the configuration data from the memory to accomplish initial
5 configuration upon power on, and/or, to read the configuration data from the memory to accomplish re-configuration during running time.

In an aspect of the present invention, the RFID tag at least includes: an RF decoding module, a controller and a power management module; wherein: the RF decoding module is adapted to receive the RF signal and decode the RF signal to obtain the configuration
10 data; the controller is adapted to control the RF decoding module and the power management module and output the configuration data obtained by the RF decoding module to the memory; and, the power management module is adapted to provide power for the RF decoding module and the controller.

In an aspect of the present invention, when the RFID tag is a passive RFID tag, the
15 power management module is further adapted to receive the RF signal and obtain power from the RF signal.

In an aspect of the present invention, the main circuit at least includes a control unit and at least one application function module; wherein: the control unit is adapted to read the configuration data from the memory, and accomplish configuration for the at least one
20 application function module using the configuration data.

In an aspect of the present invention, the wireless device includes a wireless sensor in a wireless sensor network; the at least one application function module at least includes: a wireless communication module and a sensor module; the configuration data at least
25 include: configuration data related with wireless links and configuration data related with sensors; and, the control unit is adapted to utilize the configuration related with wireless links to accomplish configuration for the wireless communication module, and utilize the configuration data related with sensors to accomplish configuration for the sensor module.

An aspect of the present invention further provides a wireless system, including at
30 least one wireless device as aforementioned and a Radio Frequency Identification (RFID) Reader, wherein: the RFID Reader is adapted to transmit a Radio Frequency (RF) signal carrying configuration data; each wireless device is adapted to obtain the configuration data from the RF signal carrying the configuration data, and configure according to the

configuration data.

An aspect of the present invention also provides a wireless system, including at least one wireless device and a Radio Frequency Identification (RFID) Reader, wherein: each wireless device is connected to an RFID tag; the RFID Reader is adapted to transmit a Radio Frequency (RF) signal carrying configuration data; each RFID tag is adapted to obtain the configuration data from the RF signal transmitted by the RFID Reader; and, each wireless device is adapted to configure according to the configuration data obtained by the RFID tag connected thereto.

An aspect of the present invention further provides a machine-readable storage medium, adapted to store instructions for enabling a machine to implement the method for configuring a wireless device as aforementioned.

By adopting the embodiments of the present invention, the configuration of the wireless device can be realized with low costs and better implementation results.

Brief Description of the Drawings

The exemplary embodiments of the present invention will be described in detail hereinafter with accompany drawings to make those ordinarily skilled in this art understand the aforementioned and other features and advantages of the present invention more clearly; wherein:

Figure 1 is a flow chart of a method according to an embodiment of the present invention;

Figure 2 is a flow chart of a method according to an embodiment of the present invention;

Figure 3 is a diagram showing a structure of a system according to an embodiment of the present invention;

Figure 4 is a diagram showing a structure of a wireless device according to an embodiment of the present invention; and,

Figure 5 is a diagram showing a specific example of a wireless sensor network applied with an embodiment of the present invention.

Embodiments of the Invention

The present invention is further described in detail with the accompany drawings and embodiments hereinafter. It should be understand that the specific embodiments described herein are just for explaining, but not for limiting the present invention.

5 An embodiment of the present invention provides a method for configuring a wireless device. Figure 1 is a flow chart of a method according to an embodiment of the present invention. In the embodiment, the wireless device is connected with a Radio Frequency Identification (RFID) tag. As shown in Figure 1, the flow chart of the method includes the following steps:

10 Step 101: The wireless device obtains configuration data from a Radio Frequency (RF) signal utilizing the RFID tag.

Herein, the wireless device may obtain the configuration data from the RF signal transmitted by a RFID Reader utilizing the RFID tag, and thus, a user may input configuration data using the RFID Reader to perform configuration for the wireless
15 device.

Step 102: The wireless device accomplishes its configuration according to the obtained configuration data.

In the above embodiment, configurations are obtained from an independent RF signal by using a RFID tag, and therefore, this configuration solution does not occupy
20 inherent communication resources of the wireless device, does not affect the inherent information interaction, and can guarantee the communication safety of the wireless device. In addition, the RFID tag adopted is very cheap and its power consumption is very low, and thus, this configuration solution is of low cost and easy to implement.

Figure 2 is a flow chart of a method according to an embodiment of the present
25 invention. In this embodiment, the wireless device is connected with an RFID tag. As shown in Figure 2, the flow chart of the method includes the following steps:

Step 201: The RFID tag receives an RF signal from an RFID Reader, decodes the RF signal to obtain configuration data.

Step 202: The configuration data obtained in Step 201 are stored.

Step 203: Upon starting to work, the wireless device reads the stored configuration data to accomplish initial configuration; and/or, during the running time, the wireless device reads the stored configuration data to accomplish re-configuration.

5 Specifically, the RFID tag and the wireless device may have their respective storing function, and the aforementioned Step 202 may be implemented by the RFID tag or by the wireless device. Alternatively, there may be a memory connected between the RFID tag and the wireless device, and in Step 202, the memory is responsible for storing the configuration data obtained by the RFID tag, and in Step 203, the wireless device will
10 read the configuration data from the memory.

In the above embodiments, the RFID tag may be an active RFID tag or a passive RFID tag. Those skilled in this art can understand that the active RFID tag is equipped with a power supply which is usually a battery, and in contrast, the passive RFID tag is not equipped with any power supply.

15 When the passive RFID tag is adopted in the embodiment of the present invention, the passive RFID tag may further obtain power from the received RF signal.

The aforementioned RFID tag may be embedded in the wireless device, or may be externally connected with the wireless device.

The embodiments of the present invention may be applied to the wireless sensor
20 network to realize the configuration for the wireless sensor, and in this case, the wireless device may be the wireless sensor. Specifically, the aforementioned configuration data may include at least: configuration data related with wireless links and/or those related with sensors. Wherein, the configuration data related with wireless links may include at least one of channel frequency, data rate, modulation parameter(s) and synchronization
25 parameter(s), and the configuration data related with sensors may include at least one of checking threshold(s), algorithm setting(s), sampling rate and reporting cycle. The embodiments of the present invention do not limit specific contents of the configuration data, any kinds of configuration data that are possible needed by the wireless device may be regarded as the configuration data of the embodiments of the present invention.

In the above embodiment of the present invention, the RFID tag is used to obtain configuration data from an independent RF signal, so that before the wireless device starts up, the configuration data can be obtained and stored, and they can be read by the wireless device after its starting up, and thus, the power of the wireless device consumed on configuration can be reduced as little as possible. Meanwhile, when the wireless link of the wireless device is disconnected because of incorrect configuration, new configuration data can be sent to the wireless device through an independent RF signal to make the wireless device accomplish re-configuration automatically. To sum up, it is very easy and convenient to apply the configuration solution provided by the embodiment of the present invention, and this solution can guarantee the safety of the wireless device.

Based on the above method, an embodiment of the present invention provides a wireless system, and the system includes at least one wireless device. Figure 3 is a diagram showing a structure of the system according to an embodiment of the present invention. As shown in Figure 3, the system includes N wireless devices (Device 1, Device 2, ..., and Device N) and an RFID Reader, where, each wireless device is embedded with an RFID tag.

Wherein, the RFID Reader sends out an RF signal carrying configuration data, each RFID tag obtains the configuration data from the RF signal sent out by the RFID Reader, and each wireless device accomplishes its configuration according to the configuration data obtained by its corresponding RFID tag.

Alternatively, each wireless device may externally connect with an RFID tag.

Specifically, the RFID tag may be an active RFID tag or a passive RFID tag, and when it is the passive one, the passive RFID tag may further obtain power from the RF signal sent out by the RFID Reader.

The embodiment of the present invention may be applied to the wireless sensor network to accomplish the configuration for the wireless sensor, and in this case, the above N wireless device(s) is(are) N wireless sensor(s).

Based on the aforementioned method, the embodiments of the present invention further provide a wireless device. Figure 4 is a diagram showing a structure of a wireless

device according to an embodiment of the present invention. As shown in Figure 4, the wireless device at least includes a main circuit 401 and an RFID tag 402.

Wherein, the RFID tag 402 is adapted to obtain configuration data from an RF signal, and the main circuit 401 is adapted to accomplish its configuration according to the configuration data obtained by the RFID tag 402.

Optionally, the wireless device may further include a memory 403 connected between the main circuit 401 and the RFID tag 402, the memory 403 is adapted to store the configuration data obtained by the RFID tag 402. The main circuit 401 may read the configuration data from the memory 403 upon its power on to accomplish the main circuit 401's initial configuration, and/or, may read the configuration data from the memory 403 during its running time to accomplish the main circuit 401's re-configuration. Here, the memory 403 may be a non-volatile memory, so that the configuration data can remain without power supply, and this memory 403 may be a 2-port memory, or may be a single-port memory that can be accessed by two masters (the main circuit 401 and the RFID tag 402) separately. Further, when being accessed by the RFID tag 402, the memory 403 may be powered by the RFID tag 402 or the battery of the wireless device. The memory 403 has very low power consumption when being accessed by the RFID tag 402 and has zero power consumption at off mode, and the memory 403 will be in off mode in most of time during the whole lifetime of the wireless device (e.g., the wireless sensor), and therefore, even when powered by the battery of the wireless device, the additional power consumption of the memory 403 is ultra low.

Specifically, the RFID tag 402 may include: an RF decoding module 4021, a controller 4022 and a power management module 4023. Wherein, the RF decoding module 4021 is adapted to receive an RF signal and decode the RF signal to obtain configuration data; the controller 4022 is adapted to control the RF decoding module 4021 and the power management module 4023, and output to the memory 403 the configuration data obtained by the RF decoding module 4021; and, the power management module 4023 is adapted to provide power for the RF decoding module 4021 and the controller 4022. Here, the power management module 4023 may further receive the RF signal and obtain power from the RF signal when the RFID tag 402 is a passive one, in order to provide power for the RF decoding module 4021 and the controller 4022;

and otherwise when the RFID tag 402 is an active one, the power management module 4023 may obtain power from the power supply of the RFID tag 402 to provide power for the RF decoding module 4021 and the controller 4022.

Specifically, the main circuit 401 may include a control unit 4011 and at least one application function module 4012. Wherein, the control unit 4011 is adapted to control the at least one application function module 4012, read the configuration data from the memory 403, and accomplish configuration for the at least one application function module 4012 according to the configuration data. Here, the control unit 4011 may be any electronic component that can realize controlling functions, such as a Micro Control Unit (MCU), a Central Processing Unit (CPU) or etc. And the present invention does not limit which specific application function module(s) 4012 should be included in the main circuit 401, and this is related to the specific application of the wireless device according to the embodiment of the present invention.

The embodiments of the present invention further provide a wireless system which includes at least one wireless device provided by the above embodiments of the present invention and an RFID reader, where, the RFID reader transmits an RF signal carrying configuration data, the wireless device obtains the configuration data from the RF signal carrying the configuration data and accomplishes configuration according to the configuration data. Here, the structure and operation principle of the wireless device has been described above and will not be discussed again herein. When the embodiment of the present invention is applied to the wireless sensor network, the wireless device may be the wireless sensor in the wireless sensor network, and in this case, the application function modules 4012 included in the main circuit 401 at least include: a wireless communication module and a sensor module, and the aforementioned configuration data include at least: configuration data related with wireless links and those related with sensors. The control unit 4011 accomplishes the configuration for the wireless communication module using the configuration data related with wireless links and uses the configuration data related with sensors to accomplish the configuration for the sensor module. Wherein, the sensor module is adapted to accomplish detection to the working field and the wireless communication data is adapted to communication with the management node in the wireless sensor network to report the data detected by the sensor module to the management node. Here, the specific working principle of the sensor

module and the wireless communication module belongs to the contents of the prior art which will not be discussed herein in detail.

Figure 5 is a diagram showing a specific example of a wireless sensor network applied with an embodiment of the present invention. As shown in Figure 5, the wireless sensor is equipped with an RFID tag which receives a configuration command sent from an RFID Reader via an RF signal and obtains configuration data from the configuration command; the wireless sensor may read the configuration data obtained by the RFID tag upon its power on to accomplish its initial configuration according to the configuration data, including: configuration related with wireless links, that related with sensors and etc., so that the wireless sensor is able to establish a wireless link with the management node in the wireless sensor network, detect sensing data from the working field, and report the detected sensing data to the management node via the established wireless link; and during the running time, if it is necessary to perform re-configuration, the RFID Reader may send out a re-configuration command via an RFID signal from which the RFID tag may obtain new configuration data, and then the wireless sensor may accomplish its re-configuration according to the new configuration data.

The embodiments of the present invention can be implemented in various applications of the wireless sensor network. For example, when the wireless sensor network is deployed in a parking field to realize a parking monitoring system, battery-supplied wireless sensors are mounted under the ground surface of the parking field to detect presence of vehicles, these wireless sensors can utilize the RFID tags to receive configuration data sent through the RF signals to accomplish initial configuration and/or re-configuration, so that the user can realize configuration for these wireless sensors without picking them out from the subsurface of the ground, thereby the operation is very convenient. Moreover, the configuration data occupy resources of independent RF signals while does not consume wireless communication resources between the wireless sensor and the management node, so that this configuration solution bring no effects on the inherent information transmission in the wireless sensor network. Meanwhile, after adopting this configuration solution, the configuration data can be obtained by the RFID tag before the wireless sensor starts up, they can be read by the wireless sensor upon its power on to accomplish the initial configuration related to wireless links, sensors and etc., and thus, the user's operations in equipping the wireless

sensors and performing configuration on the wireless sensors are more convenient, and the configuration nearly consume no power of the wireless sensor.

The present invention further provides a machine-readable storage medium for storing instructions which can make a machine implement the method for configuring a wireless device as discussed in this paper. Specifically, a system or apparatus equipped with a storage medium can be provided, where, software program codes for implementing functions of any of the aforementioned embodiments are stored in this storage medium, and it can make a computer (or CPU or MPU) of the system or apparatus read out and perform the program codes stored in the storage medium.

In this case, the program codes read from the storage medium itself can implement the functions of any of the aforementioned embodiments, and therefore, the program codes and the storage medium storing the program codes form a part of the present invention.

Embodiments of the storage medium providing the program codes include a floppy disk, a hard disk, a magnetic disk, compact disk (e.g., CD-ROM, CD-R, CD-RW, DVD-ROM, DVD-RAM, DVD-RW and DVD+RW), a tape, a nonvolatile memory card and ROM). Optionally, it is possible to download the program codes from a server computer via a communication network.

In addition, it should be clear that, an operating system running on a computer can be enabled to accomplish a part of or all of actual operations by performing not only the program codes read out by the computer but also instructions based on the program codes, so as to realize functions of any of the aforementioned embodiments.

Moreover, it can be understood that, the program codes read out by the storage medium can be written into a memory adapted on an extended board inside a computer or be written into a memory adapted in an extended unit connected with a computer, and then the instructions based on the program codes enable a CPU equipped on the extended board or the extended unit is enabled to implement a part of or all of the actual operations, so as to realize functions of any of the aforementioned embodiments.

The embodiments of the present invention provide a method for configuring a wireless device, the wireless device is embedded with an RFID tag or connected with an RFID tag, and the method includes: the wireless device utilizes the RFID tag to obtain configuration data from a RF signal, and accomplish configuration according to the

obtained configuration data. The embodiments of the present invention also provide a wireless system and a wireless device. By adopting the embodiments of the present invention, the configuration of the wireless device can be effectively realized with low costs. The foregoing is only preferred embodiments of the present invention, however, is not used to limit the present invention. Any modification, change or substitution, without departing from the spirit and principle of the present invention, should be covered by the protection scope of the present invention.

5

Claims

1. A method for configuring a wireless device, wherein, the wireless device is embedded with a Radio Frequency Identification (RFID) tag or connected with an RFID tag, and the method comprises:
- 5 obtaining, by the wireless device, configuration data from a Radio Frequency (RF) signal through the RFID Tag; and
- configuring, by the wireless device, according to the obtained configuration data.
- 10 2. The method according to claim 1, wherein, the step of obtaining configuration data from a Radio Frequency (RF) signal through the RFID Tag comprises: receiving, by the RFID tag, the RF signal, and decoding the RF signal to obtain the configuration data;
- the method further comprises: storing the configuration data obtained by the RFID tag;
- 15 and,
- the step of configuring according to the obtained configuration data comprises:
- reading, by the wireless device, the stored configuration data to accomplish initial configuration upon power on; and/or,
- reading, by the wireless device, the stored configuration data to accomplish
- 20 re-configuration during running time.
3. The method according to claim 1, wherein, when the RFID tag is a passive RFID tag, the method further comprises: obtaining, by the passive RFID tag, power from the RF signal.
- 25
4. The method according to any of claims 1 to 3, wherein, the wireless device comprises a wireless sensor in a wireless sensor network.
5. The method according to claim 4, wherein, the configuration data at least
- 30 comprise: configuration data related with wireless links, and/or configuration data related with sensors.

6. A wireless device, comprising a main circuit, and a Radio Frequency Identification (RFID) tag; wherein:

the RFID tag is adapted to obtain configuration data from a Radio Frequency (RF) signal; and,

5 the main circuit is adapted to configure according to the configuration data obtained by the RFID tag.

7. The device according to claim 6, further comprising: a memory, adapted to store the configuration data obtained by the RFID tag; wherein,

10 the main circuit is adapted to read the configuration data from the memory to accomplish initial configuration upon power on, and/or, to read the configuration data from the memory to accomplish re-configuration during running time.

8. The device according claim 7, wherein, the RFID tag at least comprises: an RF decoding module, a controller and a power management module; wherein:

15 the RF decoding module is adapted to receive the RF signal and decode the RF signal to obtain the configuration data;

the controller is adapted to control the RF decoding module and the power management module and output the configuration data obtained by the RF decoding module to the memory; and,

20 the power management module is adapted to provide power for the RF decoding module and the controller.

9. The device according to claim 8, wherein, when the RFID tag is a passive RFID tag, the power management module is further adapted to receive the RF signal and obtain power from the RF signal.

10. The device according to any of claims 7 to 9, wherein, the main circuit at least comprises a control unit and at least one application function module; wherein:

30 the control unit is adapted to read the configuration data from the memory, and accomplish configuration for the at least one application function module using the configuration data.

11. The device according to claim 10, wherein, the wireless device comprises a wireless sensor in a wireless sensor network;

the at least one application function module at least comprises: a wireless communication module and a sensor module;

5 the configuration data at least comprise: configuration data related with wireless links and configuration data related with sensors; and,

the control unit is adapted to utilize the configuration related with wireless links to accomplish configuration for the wireless communication module, and utilize the configuration data related with sensors to accomplish configuration for the sensor
10 module.

12. A wireless system , comprising at least one wireless device according to any of claims 6 to 10 and a Radio Frequency Identification (RFID) Reader, wherein:

the RFID Reader is adapted to transmit a Radio Frequency (RF) signal carrying
15 configuration data;

each wireless device is adapted to obtain the configuration data from the RF signal carrying the configuration data, and configure according to the configuration data.

13. A wireless system , comprising at least one wireless device and a Radio
20 Frequency Identification (RFID) Reader, wherein:

each wireless device is connected to an RFID tag;

the RFID Reader is adapted to transmit a Radio Frequency (RF) signal carrying configuration data;

each RFID tag is adapted to obtain the configuration data from the RF signal
25 transmitted by the RFID Reader; and,

each wireless device is adapted to configure according to the configuration data obtained by the RFID tag connected thereto.

14. A machine-readable storage medium, adapted to store instructions for enabling a
30 machine to implement the method for configuring a wireless device according to any of claims 1 to 5.

1/3

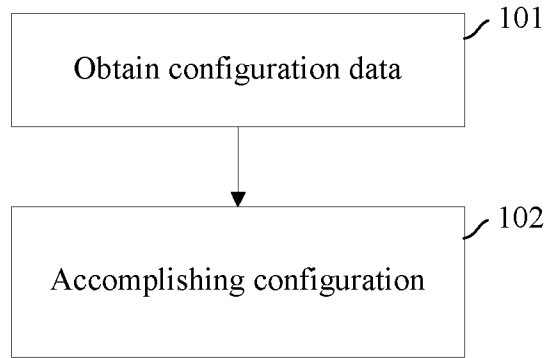

Figure 1

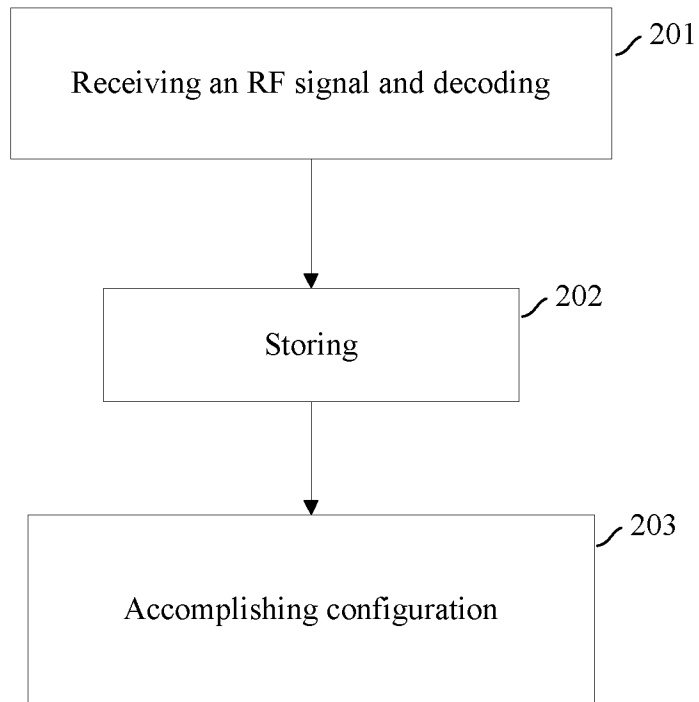

Figure 2

2/3

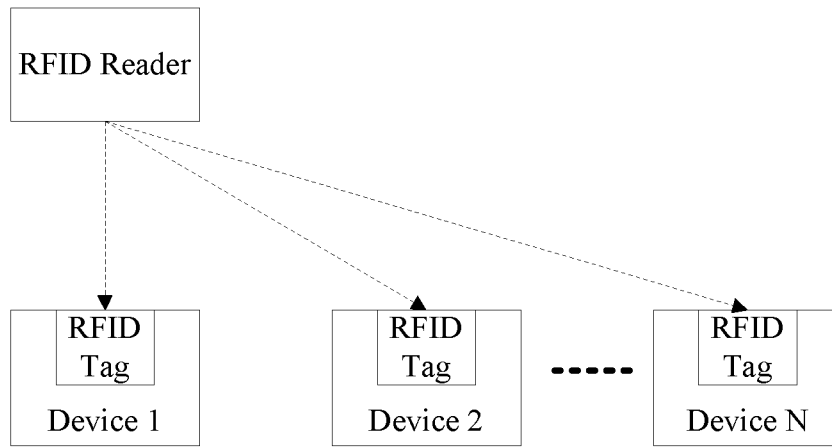

Figure 3

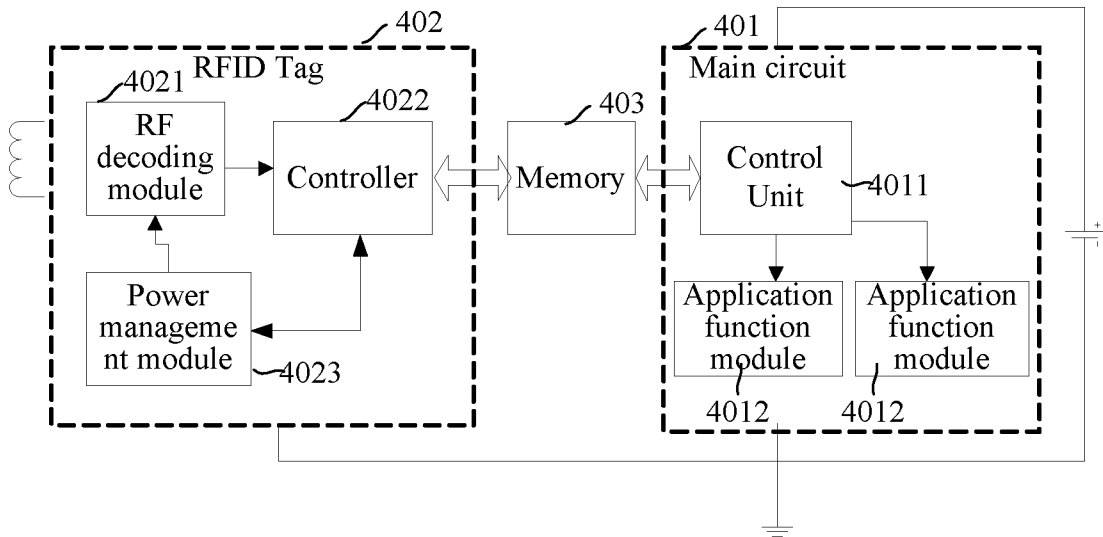

Figure 4

3/3

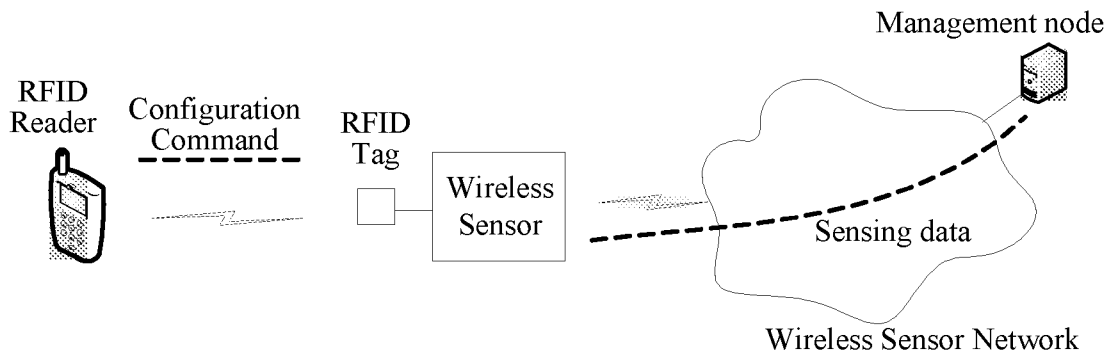

Figure 5

INTERNATIONAL SEARCH REPORT

International application No.

PCT/CN2011/072312

A. CLASSIFICATION OF SUBJECT MATTER

See the extra sheet

According to International Patent Classification (IPC) or to both national classification and IPC

B. FIELDS SEARCHED

Minimum documentation searched (classification system followed by classification symbols)

IPC: G06K, H04L, H04Q, H04B, G06F

Documentation searched other than minimum documentation to the extent that such documents are included in the fields searched

Electronic data base consulted during the international search (name of data base and, where practicable, search terms used)

VEN, CNABS, WPI, EPODOC: sensor? , RFID tag, Radio frequency identification tag, configur+, reset, setting?, adjust+, reconfigure+, amend+, correct +, modif+, parameter?

C. DOCUMENTS CONSIDERED TO BE RELEVANT

Category*	Citation of document, with indication, where appropriate, of the relevant passages	Relevant to claim No.
X	US 2008/0204199 A1 (CISCO TECHNOLOGY) 28 Aug. 2008 (28.08.2008) the abstract, paragraphs [0020]-[0021],[0029],[0044],[0048], figs. 5,6	1,2,4,6-8, 10, 12-14
Y	ditto	3,5, 9,11
A	WO2006026741 A1 (LIFESCAN SCOTLAND LIMITED) 09 Mar. 2006 (09.03.2006) the whole document	1-14

Further documents are listed in the continuation of Box C.

See patent family annex.

<p>* Special categories of cited documents:</p> <p>“A” document defining the general state of the art which is not considered to be of particular relevance</p> <p>“E” earlier application or patent but published on or after the international filing date</p> <p>“L” document which may throw doubts on priority claim (S) or which is cited to establish the publication date of another citation or other special reason (as specified)</p> <p>“O” document referring to an oral disclosure, use, exhibition or other means</p> <p>“P” document published prior to the international filing date but later than the priority date claimed</p>	<p>“T” later document published after the international filing date or priority date and not in conflict with the application but cited to understand the principle or theory underlying the invention</p> <p>“X” document of particular relevance; the claimed invention cannot be considered novel or cannot be considered to involve an inventive step when the document is taken alone</p> <p>“Y” document of particular relevance; the claimed invention cannot be considered to involve an inventive step when the document is combined with one or more other such documents, such combination being obvious to a person skilled in the art</p> <p>“&”document member of the same patent family</p>
--	--

Date of the actual completion of the international search
23 Dec. 2011 (23.12.2011)

Date of mailing of the international search report
05 Jan. 2012 (05.01.2012)

Name and mailing address of the ISA/CN
The State Intellectual Property Office, the P.R.China
6 Xitucheng Rd., Jimen Bridge, Haidian District, Beijing, China
100088
Facsimile No. 86-10-62019451

Authorized officer
WU, Xinghua
Telephone No. (86-10)62411371

INTERNATIONAL SEARCH REPORT

International application No.

PCT/CN2011/072312

C (Continuation). DOCUMENTS CONSIDERED TO BE RELEVANT

Category*	Citation of document, with indication, where appropriate, of the relevant passages	Relevant to claim No.
Y	US 2003/0183697 A1 (PORTER, Jeffrey Wayne) 02 Oct. 2003 (02.10.2003) the paragraph [0004]	3,5, 9,11
A	the abstract, paragraphs [0003]-[0005], [0021]-[0031], [0034]-[0041], [0050]-[0057], fig.1, & claims 1-5	1,2,4,6-8, 10, 12-14
A	US 2008/0129460 A1 (ABRAHAM, Thomas C.) 05 Jun. 2008 (05.06.2008) the whole document	1-14
A	US 2005/0012617 A1 (DISILVESTRO, Mark) 20 Jan. 2005 (20.01.2005) the whole document	1-14
A	CN 101937494 A (SHENZHEN YANXIANG COMMUNICATION TERMINAL) 25 Jan. 2011 (05.01.2011) the whole document	1-14

INTERNATIONAL SEARCH REPORT
Information on patent family members

International application No. PCT/CN2011/072312
--

Patent Documents referred in the Report	Publication Date	Patent Family	Publication Date
US 2008/0204199 A1	28.08.2008	None	
WO2006026741 A1	09.03.2006	CN 101091114 A	19.12.2007
		JP2008511841T	17.04.2008
		WO2006026748 A1	09.03.2006
		EP1794585 A1	13.06.2007
		US2008114228 A1	15.05.2008
		US2007270672 A1	22.11.2007
US 2003/0183697 A1	02.10.2003	None	
US 2008/0129460 A1	05.06.2008	None	
US 2005/0012617 A1	20.01.2005	US7218232 B2	15.05.2007
CN 101937494 A	05.01.2011	None	

INTERNATIONAL SEARCH REPORT

International application No.

PCT/CN2011/072312

CLASSIFICATION OF SUBJECT MATTER

H04L 12/24 (2006.01) i

G06K 19/067 (2006.01) i