

G. Weiland,
Horse Rake.

2 Sheets, Sheet 1.

No. 101,196.

Patented Mar. 22, 1870.

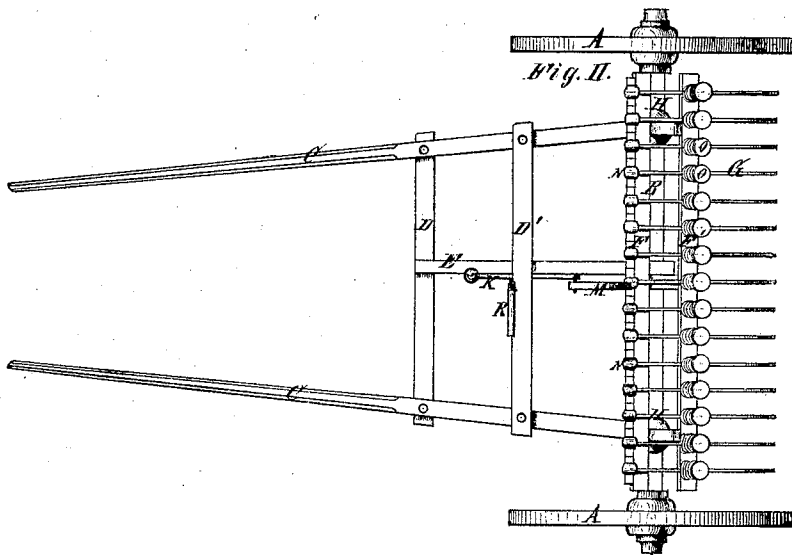
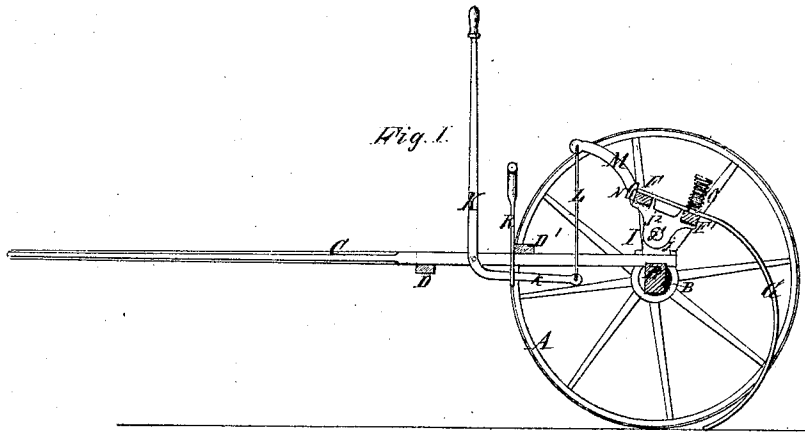

Victor H. Becker.
John J. Conner. }
Witnesses.

G. Weiland Inventor.
by F. A. S. H. V. H. A. T.

G. Weiland.
Horse Brake.

2 Sheets, Sheet 2

No. 101,196.

Patented Mar. 22, 1870.

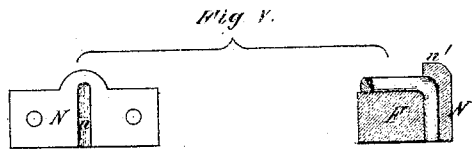
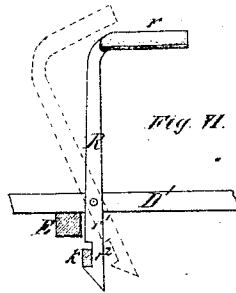
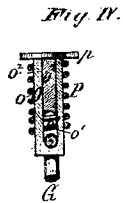
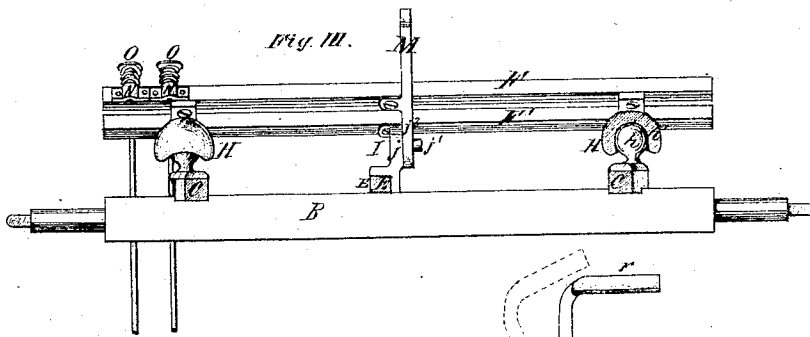

Victor H. Becker
Jno. J. Bonner
Witnesses

G. Weiland
Inventor
by Tolbruh & Heydt
Attys.

United States Patent Office.

GODFRIED WEILAND, OF DAYTON, OHIO.

Letters Patent No. 101,196, dated March 22, 1870; antedated December 14, 1869.

IMPROVEMENT IN HORSE HAY-RAKES.

The Schedule referred to in these Letters Patent and making part of the same.

I, GODFRIED WEILAND, of Dayton, in the county of Montgomery and State of Ohio, have invented a certain Improvement in Horse-Rakes, of which the following is a specification.

My invention relates to that class of wheeled horse-rakes which is furnished with elastic wire teeth attached to a rake-head, which is hinged to the main frame of the machine, and operated by a hand-lever.

My invention consists of two ball-and-socket joints, with an intermediate hinge, so constructed and arranged as to hinge the rake-head to the main frame of the machine without the use of screw-bolts, or bolts and keys, &c., as hereinafter set forth.

In the drawings—

Figure I is a sectional elevation of a horse-rake provided with my improvements.

Figure II is a plan view.

Figure III, a front elevation thereof.

Figure IV is a detached view of one of the guide-standards.

Figure V is a detached view of one of the cast boxes for fastening the rake-teeth.

Figure VI is a detached view of the locking-lever.

Like letters designate like parts in each of the figures.

A A are the wheels.

B, the axle.

C, the hills, rigidly attached to the axle, and connected by cross-beams D D'.

A^o central brace, E, runs from the forward cross-beam D, underneath the beam D', to the axle B.

These parts form the main frame of the machine.

The rake-head, located above the axle, consists of two parallel beams, F F', connected together, and arranged one behind the other. It is hinged to the axle B by two ball-and-socket joints, H H, the ball portions *h* of which are fastened to the axle, while the socketed portions *h'* are attached to the under side of the rake-head.

Between these two joints is arranged a hinge, I, forming an additional connection and means for securing the rake-head to the axle B.

The lower portion *j* of this hinge is fastened to the axle B, and is cast with a stud or pin, *j'*, which fits into an eye provided in the upper portion *j''* of the hinge attached to the rake-head.

The parts being connected together, as shown, the hinge I prevents the vertical displacement of the ball-and-socket joints, while the construction of the latter is such as to prevent lateral derangement.

In order to fasten the rake-teeth G to the rake-head, I bend the upper end or head of said teeth at right angles to the straight part thereof. A cast box

or socket, N, having a groove, *n*, receiving the bent head of the tooth, and a top piece, *n'*, overlapping said part of the tooth, is provided for each tooth, and fastened to the face of the front beam F of the rake-head. The head of the tooth is held firmly between this box and the beam F, the groove *n* in the box retaining the same against lateral movement, while the projection *n'* prevents any vertical displacement of the same.

A guide-standard, O, attached to the beam F' of the rake-head, is provided for each tooth, the latter passing through a vertical slot, *o'*, in the standard, which retains the tooth against lateral movement, but allows of a vertical play of the same.

The length of the slot *o'* is adjusted by a stop, *o''*, filling the former to a certain extent, and thereby limiting the vertical movement.

A coiled spring, P, inclosing the body of the standard, expands between the head *p* of the same and the tooth G, and renders the latter self-adjusting to the irregularities of the ground when raking.

The improved mode of hinging the rake-head dispenses with the use of screw-bolts, belts, and keys, &c., which parts are frequently lost, and thereby occasion greater or lesser inconvenience, while the hinging is such as to allow the rake-head all necessary freedom of movement.

K is a bent hand-lever pivoted to the frame, the short arm of which is connected, by a rod, L, to an arm, M, cast with and projecting from the upper portion of the hinge L.

The locking-lever R is pivoted to the cross-piece D' of the main frame in such a manner that the bent upper portion *r* of the same will preponderate, and press the lower portion *r'* of same against the lower arm *k* of hand-lever K, which is firmly held in a notch, *r''*, with which the lower portion *r'* of lever R is provided.

A pull applied to the upper portion *r* of locking-lever R will release the lever K, and permit it to be swung backward, to oscillate the rake-head and raise the teeth from the ground.

By letting go the hand-lever K, the gravity of the parts will cause them to assume their former position.

What I claim as my invention is—

The ball-and-socket joints H H and intermediate hinge I, when arranged with the axle B and the rake-head, substantially as and for the purpose set forth.

GODFRIED WEILAND.

Witnesses:

JESSE DARLINGTON,
THOS. D. MITCHELL.