

Feb. 6, 1951

A. E. SMITH

2,540,461

COMBINATION AMPOULE SYRINGE

Filed March 1, 1948

Fig. 1.

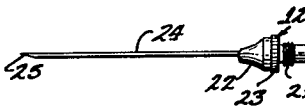

Fig. 2.

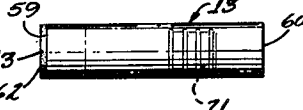

Fig. 3.

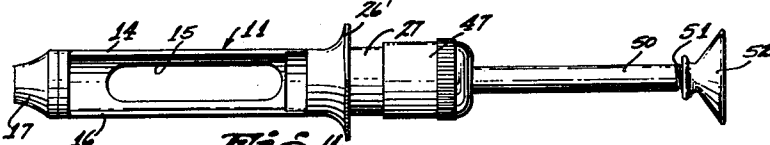

Fig. 4.

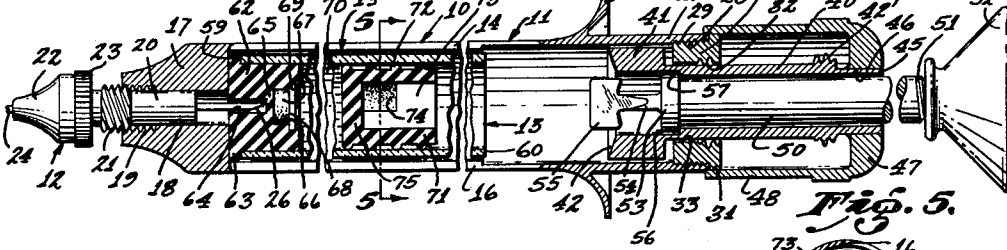

Fig. 5.

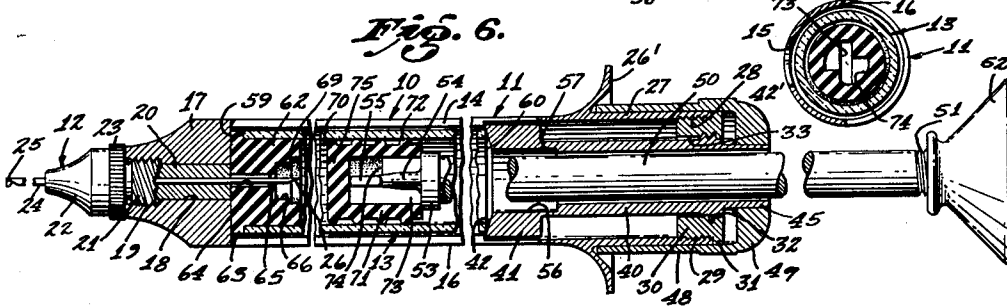

Fig. 6.

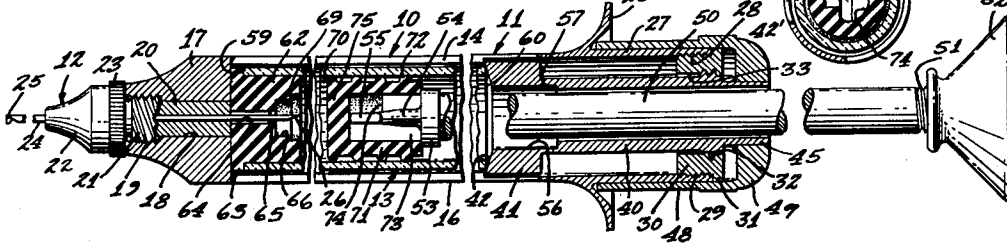

Fig. 7.

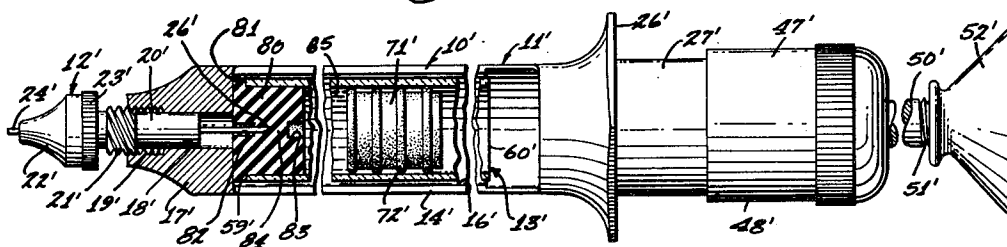
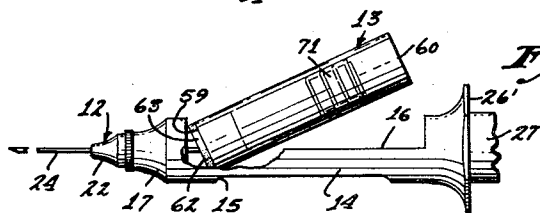

Fig. 8.



INVENTOR.

ARTHUR E. SMITH

BY

Arthur E. Smith
ATTORNEY

UNITED STATES PATENT OFFICE

2,540,461

COMBINATION AMPOULE SYRINGE

Arthur E. Smith, Los Angeles, Calif.

Application March 1, 1948, Serial No. 12,257

1 Claim. (Cl. 128—218)

1

This invention relates to a combination ampule syringe.

The general object of the invention is to provide a syringe of the combination ampule type by means of which the operator can remove a needle from the ampule barrel for sterilizing or other purposes and may thereafter place an ampule in the barrel and replace the needle to provide a fresh solution, or, if desired, the needle may be first placed upon the syringe, after which the operator may place an ampule in the syringe and may thus cause a fresh solution to be prepared.

A further object of the invention is to provide a syringe including a novel hypodermic needle mount.

A further object of the invention is to provide a syringe barrel which includes novel means for mounting a hypodermic needle.

Another object of the invention is to provide an improved hypodermic syringe barrel.

Other objects and advantages of my invention will be apparent from the following description taken in connection with the accompanying drawings, wherein:

Fig. 1 is a side elevation of a needle and a needle mount embodying the features of my invention;

Fig. 2 is a side elevation of the ampule;

Fig. 3 is a side elevation of the syringe barrel;

Fig. 4 is an enlarged, central, sectional view showing the syringe barrel with the ampule therein and with the needle mount partially seated;

Fig. 5 is a section taken on line 5—5, Fig. 4;

Fig. 6 is a view similar to Fig. 4 showing the needle mount securely seated and the plunger coupled to the piston stopper;

Fig. 7 is an enlarged, central, sectional view with parts in elevation showing a modified type of front stopper, and

Fig. 8 is a fragmentary side elevation showing the manner in which an ampule is inserted after the needle has been positioned.

Referring to the drawing by reference characters, I have shown my invention as embodied in a combination ampule syringe 10. As shown, the syringe includes a barrel 11, a needle mount and needle 12 and an ampule 13. The barrel 11 includes a tubular body 14 which has an elongated viewing slot 15 at one side and at the other side has a large slot 16 through which the ampule 13 may be inserted. The barrel includes a front end 17 which has a cylindrical axial bore 18 which is threaded as at 19 at its

2

outer end. The needle mount includes a cylindrical body 20 which slides within the bore 18. A threaded portion 21 on the needle mount engages the threaded portion 19 to position the needle in proper place. The needle mount includes a tapered body 22 having a knurled finger engaging portion 23 thereon. A needle 24, having a sharpened forward tip 25 and a sharpened rear end 26, extends axially through the needle mount and is secured therein as by brazing. Adjacent to the rear end the barrel is provided with a finger-engaging flange 26' while the rear portion 27 of the barrel is slightly enlarged and at its extreme inner end is internally threaded as at 28.

The threads 28 engage external threads 29 on a collar 30 which has a cylindrical end flange 31 engaging the end of the barrel. The collar is internally threaded as at 32 and in advance of the threads includes a cylindrical portion 33. The portion 33 serves as a guide for a cylindrical holding member 40. The forward end of the holding member 40 is enlarged as at 41 and is beveled as at 42 on its end face to engage and center the ampule 13, as will be presently described. Near its outer end the holding member is threaded externally as at 42' to engage the threads 32 previously described. The holding member includes a reduced end portion 45 which engages in a bore 46 in a cap member 47 and is brazed in place. The cap member 47 includes a skirt 48 which is slightly larger than the diameter of the flange 31 and the enlarged portion 27 of the syringe barrel so that the skirt 48 may slide along the barrel from the position shown in Fig. 4 to the position shown in Fig. 6.

The holding member 40 serves as a guide for a plunger 50 which has a threaded outer end 51 threadedly engaging a thumb member 52 by means of which the plunger may be operated. At its forward end the plunger includes a flange forming shoulder 53 and in advance of the shoulder includes a reduced stem 54 which terminates in a transverse blade-like head 55. The holding member has an enlarged inner bore 56 which provides a shoulder 57 which engages the flange 53 to limit outward movement of the plunger.

The parts, including the barrel, holding member, cap member and plunger are assembled in the position shown in Fig. 3 and are then adapted to receive the ampule 13. The ampule 13 consists of a cylindrical tube, preferably made of glass or plastic, having planar front and rear ends 59 and 60. Within the front end I arrange

a stopper 62 which may be made of rubber and which includes an external flange 63 engaging the end 59 of the ampule.

The stopper 62 has an outer axial recess 64 which is separated by a diaphragm 65 from an enlarged inner recess 66 in which I arrange a medicinal tablet 67. A sealing disc 68, arranged in a recess 69, holds the tablet 67 in place so that it cannot enter the vehicle 70 in the ampule.

At its inner end the ampule includes a piston stopper 71 which has peripheral beads 72 thereon. The stopper 71 includes a transverse slot 73 which extends inwardly, and at the inner end thereof communicates with sector shaped recesses 74. The recesses 74 are of a depth to receive the head 55 and the construction is such that when the plunger is moved forwardly the head 55 will enter the slot 73 and move in this slot until it is aligned with the sector shaped recesses, whereupon forward movement of the plunger will cease due to engagement with the end wall 75 of the piston stopper. The plunger may then be turned substantially 90° so that the member 55 will be locked to the piston stopper.

When the plunger is thus locked to the piston stopper the flange 53 on the front end of the plunger engages and slightly presses against the rear end of the piston stopper to thus tightly lock the plunger against longitudinal movement relative to the stopper.

In use the ampule may be first placed in the barrel, after which the holding member 40 may be moved to position so that the threads 42' engage the threads 32, at which time the ampule will be centered and will be urged forwardly in the barrel. The needle mount may then be inserted in the bore 13 and may be rotated so that the threads 19 and 21 are engaged. As shown in Fig. 4, the threads 19 and 21 engage just before the tip 26 engages the diaphragm 65. Further rotation of the needle mount will cause the needle to move inwardly, thus piercing the diaphragm 65. The needle will advance until it dislodges the disc 68, whereupon the drug will be placed in communication with the vehicle to thus prepare a fresh solution. The injection is then made and the thumb member 52 is pushed slightly forward and then withdrawn. This causes the piston stopper to first move into the ampule and then to recede. If blood is drawn into the ampule, it will indicate that the needle is in a blood vessel, whereupon the needle is withdrawn and a fresh injection is made. When the needle has been correctly inserted, the full injection is made, after which the needle is withdrawn from the patient and the ampule is removed from the barrel and thrown away.

In Fig. 7 I show a modification of my invention wherein parts similar to those previously described are designated by single primed reference numerals. In this modification the stopper 80 has a flange 81 and has outer and inner axial recesses 82 and 83. A diaphragm 84 closes communication between the recesses. A stock solution 85 is arranged in the ampule.

When the needle mount 12' is rotated, the inner end 26' of the needle will pierce the diaphragm 84 to thus place the needle in communication with the interior of the ampule.

In Fig. 8 I show an alternate manner of using my combination syringe. As shown in this view

and as is frequently desirable in practice, the needle mount 12 is fully seated with the needle tip entering the barrel. The ampule 13 is then inserted, with the needle tip entering the outer recess in the ampule stopper. As the ampule is pushed into place the needle pierces the diaphragm, thus preparing the syringe for use.

From the foregoing description it will be apparent that I have invented a novel syringe construction by means of which the operator may mount a needle on a syringe and may then insert an ampule to cause a solution to be made available, or the operator may first place an ampule in the syringe and may thereafter cause a needle to move into the ampule to prepare the syringe for use. It will also be apparent that I have invented a syringe which is simple in construction and assembly and which is efficient for its intended use.

Having thus described my invention, I claim:

In a syringe, a tubular body portion having a front portion which includes a threaded outer end, a closure stopper directly engaging the front portion, said closure stopper being made of pierceable rubber, a needle mount including an outwardly knurled cylindrical portion, said needle mount including a portion having threads engaging the threaded portion of said front portion, a needle fixedly carried by said mount and movable axially with the mount when the latter is advanced along the front portion, the inner end of said needle projecting beyond the inner end of the threaded portion of the mount and including a sharpened tip adapted to pierce said closure stopper, said point being disposed within said stopper when said threads on the front portion and on the needle mount first engage, said mount being rotatable whereby the threaded engagement between the needle mount and the front portion causes the needle mount to advance the needle through said closure stopper, a piston stopper remote from said closure stopper, said piston stopper being made of resilient rubber and having a plurality of spaced peripheral beads thereon which slidably engage the inner wall of the body portion of the syringe, a plunger for said piston stopper, the rear portion of the piston stopper having a rearwardly opening hole, said plunger and the wall of the piston stopper about the hole having interengaging parts to form a detachable connection between the piston stopper and the plunger, thereby permitting the plunger to advance and retract the piston stopper, said syringe having an outwardly directed finger engaging flange thereon and said plunger having an enlarged, thumb engaging, rear end.

ARTHUR E. SMITH.

REFERENCES CITED

The following references are of record in the file of this patent:

UNITED STATES PATENTS

65 Number	Name	Date
1,143,855	Panc	June 22, 1915
2,127,203	Brand	Aug. 16, 1938
2,134,144	Pincock	Oct. 25, 1938
2,268,994	Smith	Jan. 6, 1942
70 2,380,556	Smith	July 31, 1945