

(Model.)

J. A. MARSTON.  
Bail Fastener.

No. 241,683.

Patented May 17, 1881.

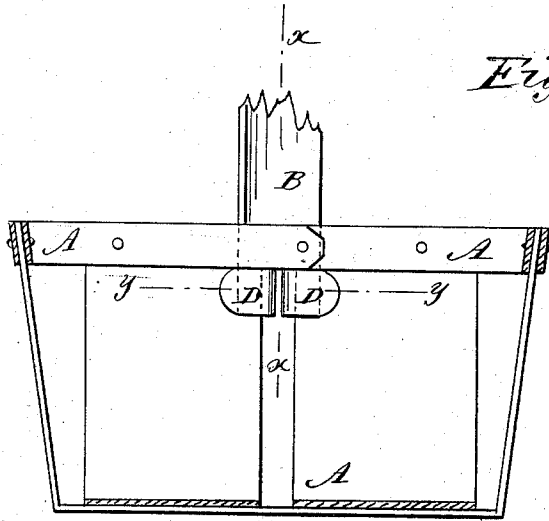

Fig. 1

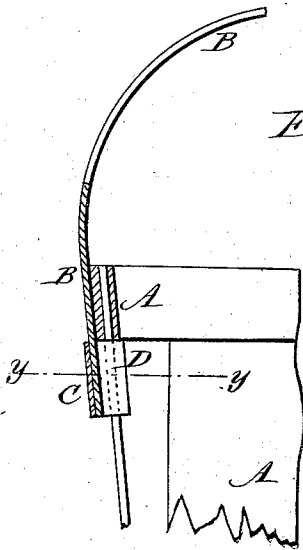

Fig. 2

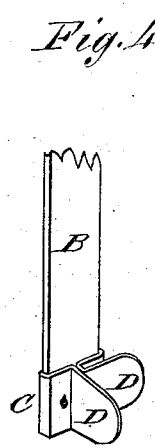

Fig. 4

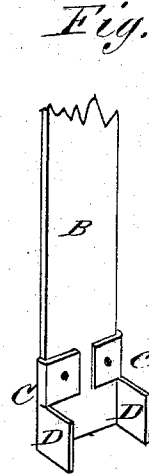
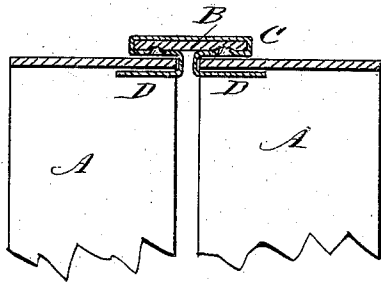

Fig. 5

Fig. 3



WITNESSES:

*C. A. New*  
*C. Sedgwick*

INVENTOR:

*J. A. Marston*  
BY *Munn Co*  
ATTORNEYS.

# UNITED STATES PATENT OFFICE.

JOHN A. MARSTON, OF CENTRE SANDWICH, NEW HAMPSHIRE.

## BAIL-FASTENER.

SPECIFICATION forming part of Letters Patent No. 241,683, dated May 17, 1881.

Application filed February 17, 1881. (Model.)

*To all whom it may concern:*

Be it known that I, JOHN A. MARSTON, of Centre Sandwich, in the county of Carroll and State of New Hampshire, have invented a new and useful Improvement in Bail-Fasteners, of

passing the projecting ends D of the fastener C through the space between two splints of the basket, or through a slit formed in a splint of the basket, and bending the said ends D down upon the surface of the basket, as shown in Figs. 1 and 3.

Figure 1 is a front elevation of my improvement shown as applied to a berry-basket. Fig. 2 is a sectional elevation of the same, taken through the line *x x*, Fig. 1. Fig. 3 is a sectional plan view of the same, taken through the line *y y*, Figs. 1 and 2. Fig. 4 is a perspective view of the fastener shown as applied to the end of a bail. Fig. 5 is a perspective view of a modified form of the fastener, shown as applied to the end of a bail.

In the modification shown in Fig. 5 the ends of the sheet-metal strip C are slitted, forming four prongs. The two upper prongs of the said ends are bent down upon the one side of the handle B, and the two lower prongs, D, of the said ends are left projecting at right angles with the bail or handle, as shown in Fig. 5. In this case the two ends D of the fastener C are passed through separate spaces or slits in the basket, and are then bent down upon the surface of the said basket. As these baskets have heretofore been made they could not be nested, and required a great amount of space for their storage.

Similar letters of reference indicate corresponding parts.

The object of this invention is to facilitate the attachment of bails or handles to baskets.

With my improvement the handles need not be attached until the baskets are to be used, and can then be quickly secured to the baskets, so that the baskets can be nested and packed in a small space.

The invention consists in combining with a splint basket and bail a metallic strip clasped about the bail, and having both ends then passed between two splints and bent divergently over them, as hereinafter described.

Having thus fully described my invention, I claim as new and desire to secure by Letters Patent—

In the accompanying drawings, A represents a berry-basket made of splints in the ordinary manner. B is the bail or handle. C is a strip of light tin or other thin sheet metal, which is bent around a suitable former into such a shape as to fit the end of the handle B, and its end parts, D, are bent outward parallel with each other, and side by side. The strip C is secured to the end of the handle B by being indented, as shown in Figs. 3, 4, and 5, or the fastening can be secured to the handle by small tacks or by other suitable means. The handle or bail B is secured to the basket A by

The combination, with a splint basket and a bail, of the metallic strip C, clasped about the bail, passed with both ends between two splints of the basket, and the ends bent divergently over said splints, as shown and described.

JOHN A. MARSTON.

Witnesses:

CHARLES S. MARSTON,  
WILLIE B. MARSTON.