

H. W. COVERT.
 PAPER-FEEDING MACHINE.

No. 182,105.

Patented Sept. 12, 1876.

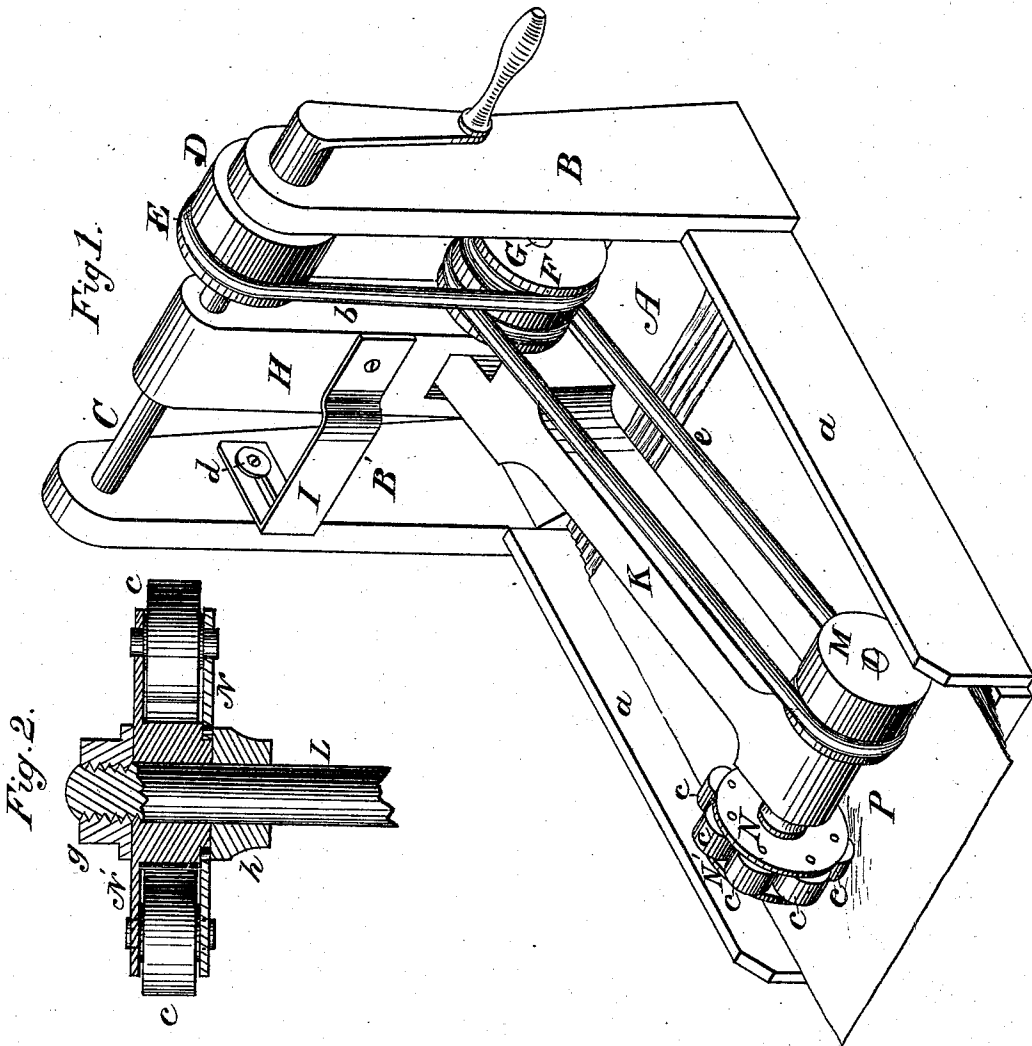

Attest:
J. H. Schott
M. Ten Eyck

Inventor:
H. W. Covert

UNITED STATES PATENT OFFICE.

HENRY W. COVERT, OF NEW YORK, N. Y.

IMPROVEMENT IN PAPER-FEEDING MACHINES.

Specification forming part of Letters Patent No. **182,105**, dated September 12, 1876; application filed June 3, 1876.

To all whom it may concern:

Be it known that I, HENRY W. COVERT, of the city of New York, county of New York, and State of New York, have invented certain new and useful Improvements in Paper-Feeders; and I do hereby declare the following to be a full, clear, and exact description thereof, such as would enable others skilled in the art to which it pertains to make and use the same, reference being had to the accompanying drawings, and to the letters of reference marked thereon, similar letters indicating corresponding parts in the different figures.

The object of this invention is to produce a machine devoid of complicity of parts, and which shall be capable of performing the function of feeding the sheets of paper singly to a printing-press, or other machine, in as perfect a manner as it is done by the costly and complicated machines which employ suction and various other devices for that purpose; and the invention consists in causing the paper to be fed forward by the passage over its surface of rollers having not only a rotating but an advancing movement, as will be hereinafter clearly described, and then specifically pointed out in the claims.

In the accompanying drawings, Figure 1 represents a perspective view of the device, and Fig. 2 details of construction not clearly exhibited by Fig. 1.

A represents the bed or table of the machine, upon which the paper is placed, suitable side pieces *a a* being provided to prevent its lateral displacement.

Two vertical standards, B and B', are secured to the bed, and carry the horizontal shaft C, which revolves in suitable bearings upon the standards, and is provided with pulley D, or other suitable devices, for giving it a rotating motion. An additional pulley, E, is also secured to the shaft C, and carries the belt *b*, which gives motion to the pulley F upon the shaft G. This shaft passes through the lower end of the pendent arm H, which is suspended from the shaft C, and is retained in position by the adjustable brace I, one end of which is secured to the standard B by means of a clamp-screw, *d*, passing through a slot in the brace. By means of this adjustment the position of the feed-wheel is regulated, so that as soon as the sheet of paper leaves the wheel

it reaches the stop on the press, ready for the grippers.

Pivoted upon the shaft G, at the lower end of the pendent H, is an arm, K', projecting horizontally over the feed-table, and carrying in bearings near its outer extremity the shaft L, upon one end of which is secured a pulley, M, receiving motion through a belt, *e*, from the pulley F upon the shaft G. The opposite end of the shaft L carries a feeding-wheel composed of two revolving disks, N N', between and near the periphery of which is pivoted a series of rollers, *c c*, in number more or less, as may be desired.

The disks and rollers are secured upon the shaft L by means of the screw-nut *g*, which forces them against a stationary collar, *h*, upon the shaft, thus causing them to rotate with it.

The operation of the machine is as follows: A pile of paper, P, is placed upon the feeding-table, with the feeding-wheel resting upon it. The latter is then rotated by the mechanism described, when the intermittent and concussive action of the advancing rollers *c c* will separate and move forward the sheets of papers singly, so that they may be caught by the grippers of a press, or other machine to which the paper is fed, the rapidity of their movement of course depending upon the speed with which the feed-wheel is driven.

Having thus described my invention, I claim as new, and desire to secure by Letters Patent, the following:

1. A feed-wheel for a paper-feeding machine, composed of a series of rollers, journaled near the periphery of two rotating disks, in the manner substantially as described.

2. In a paper-feeding machine, the feed-wheel and arm K, in combination with the pendent arm H, as specified.

3. In a paper-feeding machine, the combination of the feed-wheel with the adjustable arm K, as set forth.

In testimony whereof I have hereunto affixed my signature this 27th day of May, 1876, in presence of two witnesses.

HENRY W. COVERT.

Witnesses:

SAML. G. PAYNE,
H. R. KILLALY.